

**PS570 & PS570S
USA & Std. Export**

PS570/570S Gas Ovens

Models:

- PS570
- PS570S

PARTS MANUAL

for domestic and standard export ovens

© 2000 Middleby Marshall, Inc.



**Middleby
Marshall®** is a registered trademark of Middleby Marshall, Inc. All rights reserved.

Middleby Cooking Systems Group • 1400 Toastmaster Drive • Elgin, IL 60120 • (847)741-3300 • FAX (847)741-4406

TABLE OF CONTENTS

<i>Section</i>	<i>Page</i>
I. Key Spare Parts Kit	3
II. Installation Kit	4
III. Base Pad Kit	4
IV. Oven Panels, Window and Legs	6
V. Control Panel and Machinery Compartment	8
VI. Gas Burner System (Original Configuration - With Solenoid Valve)	10
VII. Gas Burner System (Current Configuration - With Modulating Valve)	12
VIII. Blower/Motor Assemblies, Drive and Idler Ends	14
IX. Conveyor Assembly, Single-Belt Ovens	16
X. Conveyor Assembly, Split-Belt Ovens	18

NOTE: Throughout this Parts Manual, the following abbreviations are used:

A/R = Quantity As Required

N/A = Does Not Apply

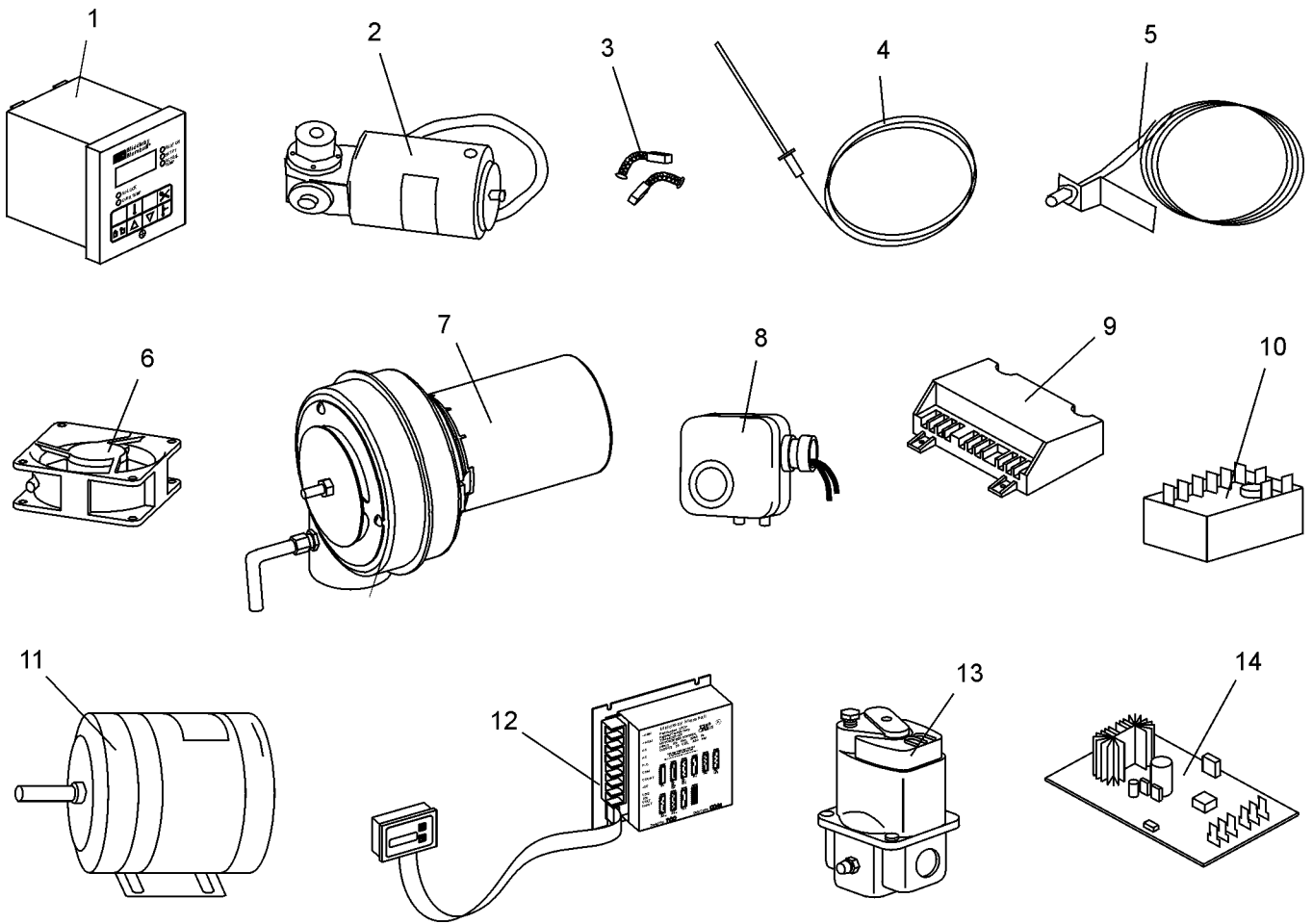

PS570 & PS570S
USA & Std. Export

I. KEY SPARE PARTS KIT

ITEM	QTY.	SINGLE CONVEYOR BELT	SPLIT BELT	EXTENDED BAKE SPLIT BELT	DESCRIPTION
1	1	36939	36939	36939	KIT, DIGITAL TEMPERATURE CONTROLLER
2	1	27384-0008	27384-0014	27384-0011	CONVEYOR DRIVE MOTOR
3	2	22450-0052	22450-0230	22450-0230	CONVEYOR DRIVE MOTOR BRUSHES
4	1	33984	33984	33984	KIT, THERMOCOUPLE
5	1	27170-0263	27170-0263	27170-0263	CONVEYOR CONTROL PICKUP ASSEMBLY
6	1	27392-0002	27392-0002	27392-0002	COOLING FAN
7	1	27170-0011	27170-0011	27170-0011	BURNER BLOWER/MOTOR ASSEMBLY
8	1	35624	35624	35624	KIT, AIR SWITCH
9	1	42810-0114	42810-0114	42810-0114	KIT, IGNITION MODULE
10	1	34982	34982	34982	HIGH LIMIT CONTROL MODULE, 115V
11	1	27381-0069	27381-0069	27381-0069	BLOWER MOTOR
12	1	37337	37337	37337	KIT, CONVEYOR SPEED CONTROLLER
13	1	41647	41647	41647	MODULATING GAS VALVE, 1/2", M420
14	1	31651	31651	31651	AMPLIFIER BOARD

INSTALLATION KIT

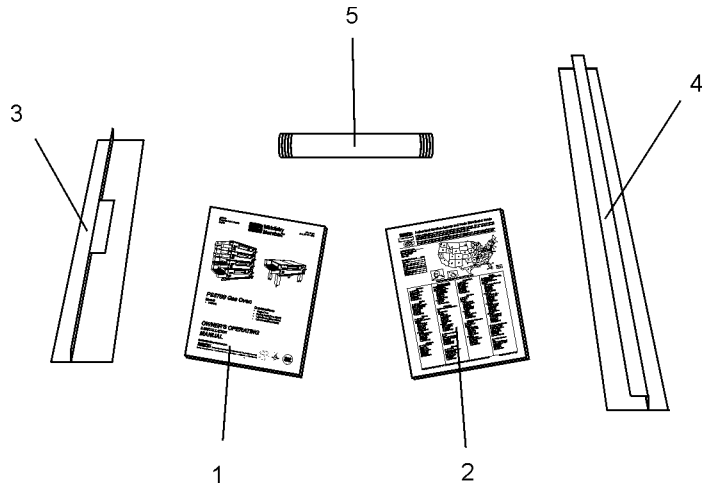

BASE PAD KIT

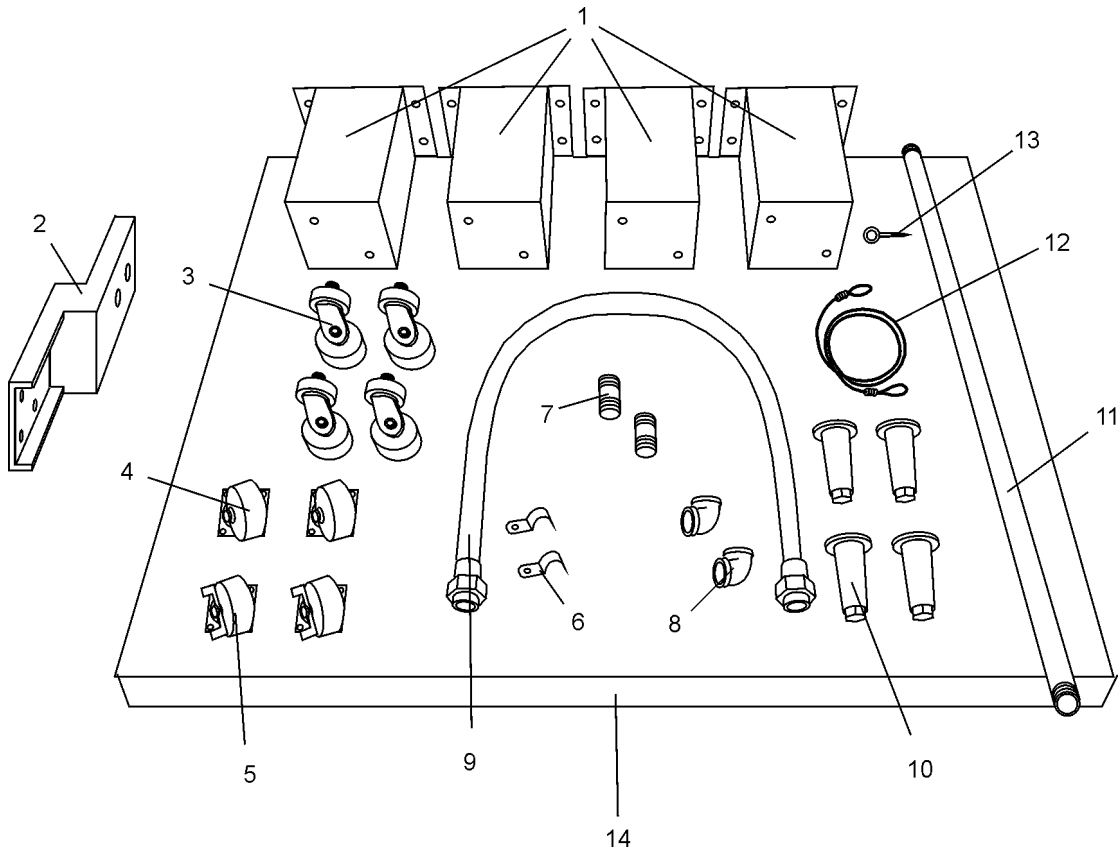

PS570 & PS570S
USA & Std. Export

II. INSTALLATION KIT

QTY

ITEM	Single Belt	Split Belt	P/N	DESCRIPTION
1	1	1	39141	OWNER'S OPERATING AND INSTALLATION MANUAL
2	1	1	1002040	AUTHORIZED SERVICE AGENCY LISTING/DISTRIBUTOR'S GUIDE
3	1	1	35900-0148	CONVEYOR REAR STOP
4	1	1	35000-1103	CONVEYOR END STOP
5	1	1	33120-0053	GAS PIPE NIPPLE

III. BASE PAD KIT

QTY

ITEM	Single Oven	Double Oven with 10"(224mm) legs	Double Oven with 15"(381mm) legs	Triple Oven	Quad Oven	P/N	DESCRIPTION
1a	4	--	--	--	--	37210-0060	LEG, 19" (483mm)
1b	--	4	--	--	--	37210-0082	LEG, 10" (254mm)
1c	--	--	4	--	--	37210-0057	LEG, 15" (381mm)
2	--	--	--	--	4	37210-0054	OUTRIGGER
3	4	4	4	4	--	37115-0102	CASTER, SWIVEL WITH 3/4" STUD
4	--	--	--	--	2	22290-0010	CASTER, SWIVEL W/PLATE (NO BRAKE)
5	--	--	--	--	2	22290-0009	CASTER, SWIVEL W/PLATE & BRAKE
6	2	2	2	2	2	27271-0004	PIPE CLAMP, 1-1/2"
7	2	2	2	2	2	33120-0055	NIPPLE, 1-1/4" DIA. X 3" L, NPT
8	2	2	2	2	2	23122-0007	ELBOW, 90°, 1-1/4" DIA.
9	1	1	1	1	1	22361-0003	GAS HOSE, 1-1/4" DIA. X 72" L
10	4	4	4	4	--	22450-0028	LEG, ADJUSTABLE WITH 3/4" STUD
11	1	1	1	1	1	33120-0056	GAS PIPE, 1-1/4" DIA. X 54" L
12	1	1	1	1	1	22450-0253	RESTRAINT CABLE, 60" (1524mm)
13	1	1	1	1	1	21392-0005	EYE BOLT/LAG SCREW
14	2	2	2	2	2	35210-0656	TOP COVER (RIGHT OR LEFT)
--	1	1	1	1	1	37210-0055	BASE PAD, INSULATED
--	8	8	8	8	8	21256-0069	SCREW, SL TRUS HD #10-32 X 1-1/4"
--	2	2	2	2	2	21292-0001	SCREW, HEX WSHR HD #10-16 X 3/4"
--	16	16	16	--	8	21216-0018	BOLT, HEX CAP 1/2-13 X 1-1/4"
--	16	16	16	--	8	21416-0003	FLAT WASHER, 1/2"
--	16	16	16	--	8	21426-0004	LOCK WASHER, 1/2"
--	--	--	--	--	16	220373	SCREW, HEX HD 3/8"-16 X 1"
--	--	--	--	--	16	21416-0001	FLAT WASHER, 3/8"
--	--	--	--	--	16	21422-0001	LOCK WASHER, 3/8"

PS570 & PS570S
USA & Std. Export

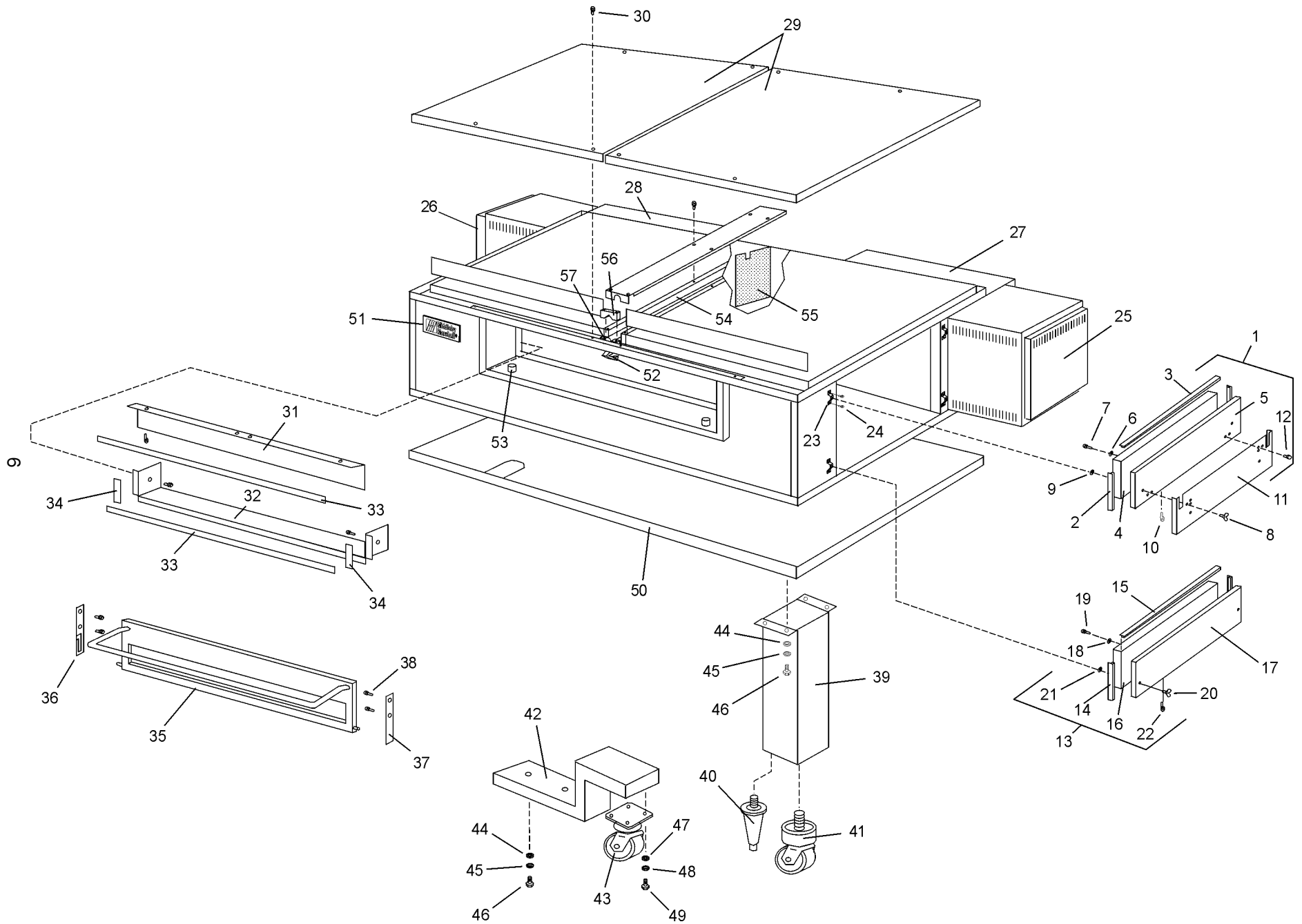

IV. OVEN PANELS, WINDOW AND LEGS

		P/N				
		PS570S	PS570			
		ID #'s contain the digits:				
ITEM	QTY.	X01,X02,X03	X04	DESCRIPTION		
1	2	42410-0126	42410-0017	42410-0017	END PLUG ASSEMBLY - UPPER	
2,3	--	22420-0142	22420-0142	22420-0142	GASKET (PER FOOT)	
4	1	35210-0368	35210-0045	35210-0045	INNER PANEL	
5	1	37210-0027	37210-0027	37210-0027	OUTER PANEL	
6	3	21416-0005	21416-0005	21416-0005	FLAT WASHER 1/4"	
7	3	21226-0022	21226-0022	21226-0022	SCREW 1/4"-20 x 1/2"	
8	2	21296-0002	21296-0002	21296-0002	WING SCREW 1/4"-20 x 1/2"	
9	2	21182-0005	21182-0005	21182-0005	NUT, PUSH TYPE RETAINER	
10	3	21281-0005	21281-0005	21281-0005	SCREW	
11	1	35210-0370	35210-0370	35210-0370	EYEBROW	
12	2	220295	220295	220295	SCREW, HEX WSHR HD #10 X 3/4"	
13	2	42410-0018	42410-0018	--	END PLUG ASSEMBLY - LOWER	
14,15	--	22420-0142	22420-0142	22420-0142	GASKET (PER FOOT)	
16	1	35210-0353	35210-0047	35210-0047	INNER PANEL	
17	1	37210-0029	37210-0029	37210-0029	OUTER PANEL	
18	2	21416-0005	21416-0005	21416-0005	FLAT WASHER 1/4"	
19	2	21226-0022	21226-0022	21226-0022	SCREW 1/4"-20 x 1/2"	
20	2	21296-0002	21296-0002	21296-0002	WING SCREW 1/4"-20 x 1/2"	
21	2	21182-0005	21182-0005	21182-0005	NUT, PUSH TYPE RETAINER	
22	3	21281-0005	21281-0005	21281-0005	SCREW	
23	8	49400-0056	49400-0056	49400-0056	MTG BRACKET W/SCREWS & NUTS	
24	A/R	21292-0001	21292-0001	21292-0001	10-16 x 3/4" TEE SCREW	
25	1	37210-0141	37210-0052	37210-0052	DOOR, MOTOR ENCLOSURE, RIGHT	
26	1	37210-0141	37210-0051	37210-0051	DOOR, MOTOR ENCLOSURE, LEFT	
27	1	42410-0129	42410-0129	42410-0129	REAR SHROUD - RIGHT	
--	1	27470-0039	27470-0039	27470-0039	EXHAUST GRILL, MOTOR CMPT.	
28	1	42410-0130	42410-0130	42410-0130	REAR SHROUD - LEFT	
--	1	27470-0039	27470-0039	27470-0039	EXHAUST GRILL, MOTOR CMPT.	
29a	2	35210-0656	--	--	TOP COVER/PS570S, W/INSULATION	
29b	1	--	35210-0127	35210-0127	TOP COVER/PS570, RIGHT	
29c	1	--	35210-0128	35210-0128	TOP COVER/PS570, LEFT	
30	8	21256-0069	21256-0069	21256-0069	SCREW, SLT TRS HD #10-32 x 1-1/4"	
31	1	35210-0028	35210-0028	35210-0028	FRAME, WINDOWS - TOP	

		P/N				
		PS570S	PS570			
		ID #'s contain the digits:				
ITEM	QTY.	X01,X02,X03	X04	DESCRIPTION		
32	1	35210-0029	--	35210-0029	FRAME, WINDOW - BOTTOM	
33,34	--	22450-0005	22450-0005	22450-0005	GASKET (PER FOOT)	
35	1	30834	--	30834	KIT, WINDOW FRAME ASSEMBLY	
36	1	35210-0348	35210-0041	35210-0041	HINGE - LH	
37	1	35210-0349	35210-0039	35210-0039	HINGE - RH	
38	4	21256-0008	21256-0008	21256-0008	SCREW, TRS HD #10-32 x 3/8"	
39a	4	37210-0060	37210-0060	37210-0060	19"/483mm LEG - SGL OVEN ONLY	
39b	4	37210-0057	37210-0057	37210-0057	15"/381mm LEG - DBL OVEN ONLY	
39c	4	37210-0082	37210-0082	37210-0082	10"/254mm LEG - DBL OVEN ONLY	
40	4	22450-0028	22450-0028	22450-0028	6"/152mm ADJ. LEG - NOT INCLUDED W/QUAD INSTALLATION	
41	4	37115-0102	37115-0102	37115-0102	SWIVEL CASTER - SINGLE, DOUBLE, TRIPLE OVENS ONLY	
42	4	37210-0054	37210-0054	37210-0054	OUTRIGGER - QUAD OVENS ONLY	
43a	2	22290-0009	22290-0009	22290-0009	SWVL CASTER W/BRAKE-QUAD ONLY	
43b	2	22290-0010	22290-0010	22290-0010	SWIVEL CASTER - QUAD OVENS ONLY	
44	24	21416-0003	21416-0003	21416-0003	FLATWASHER, 1/2" - QTY. 8 W/QUAD	
45	24	21426-0004	21426-0004	21426-0004	LOCKWASHER, 1/2" - QTY. 8 W/QUAD	
46	24	21216-0018	21216-0018	21216-0018	BOLT, HEX CAP, 1/2"-13 x 1-1/4" - QTY. 8 W/QUAD	
47	16	21416-0001	21416-0001	21416-0001	FLAT WASHER, 3/8" - QUAD ONLY	
48	16	21422-0001	21422-0001	21422-0001	LOCKWASHER, 3/8" - QUAD ONLY	
49	16	21216-0001	21216-0001	21216-0001	BOLT, HEX CAP, 3/8"-16 x 1"	
50	1	37210-0055	37210-0055	37210-0055	BASE PAD	
51	1	22500-0021	22500-0021	22500-0021	NAME PLATE	
52	1	42410-0008	42400-0087	42400-0087	LATCH ASSEMBLY	
53	2	30927	30927	30927	BUMPER, WINDOW	
FLAME GATE ASSEMBLY (IF SO EQUIPPED)						
54	1	35210-0511	N/A	N/A	TUBE, FLAME GATE	
55	1	35210-0555	N/A	N/A	FLAME GATE	
56	1	35210-0508	N/A	N/A	BRACKET, FLAME GATE	
57	1	35210-0510	N/A	N/A	CLAMP, FLAME GATE	

PS570 & PS570S
USA & Std. Export

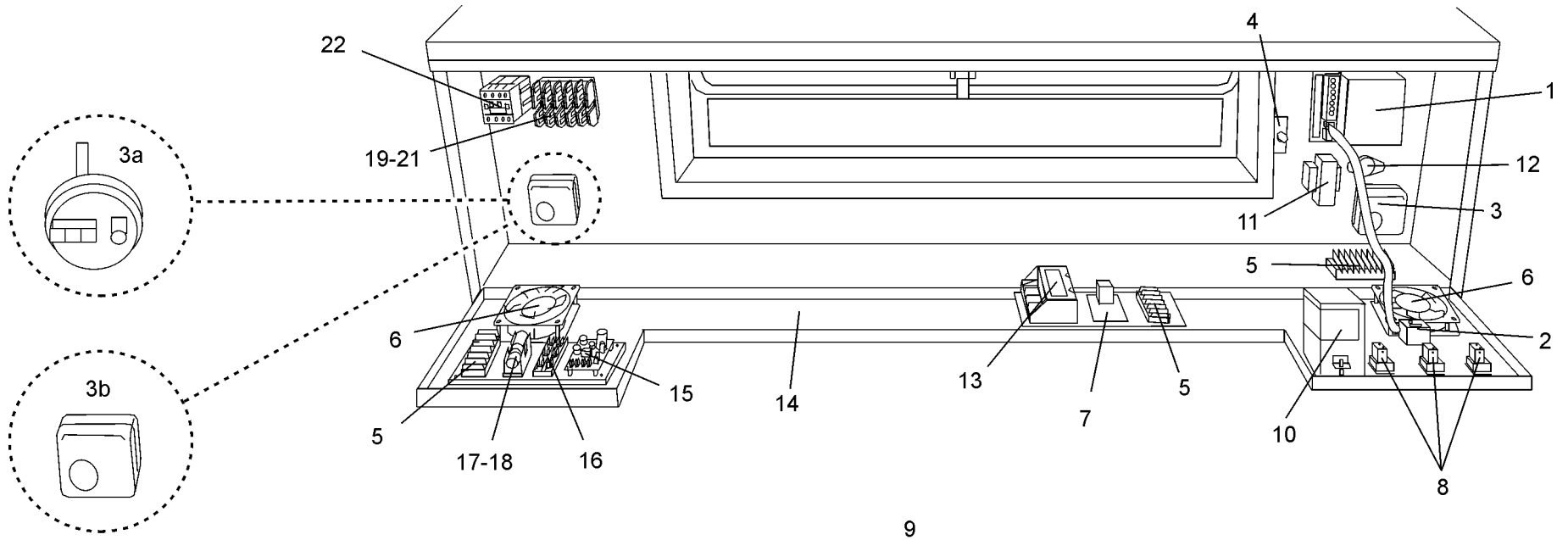

8

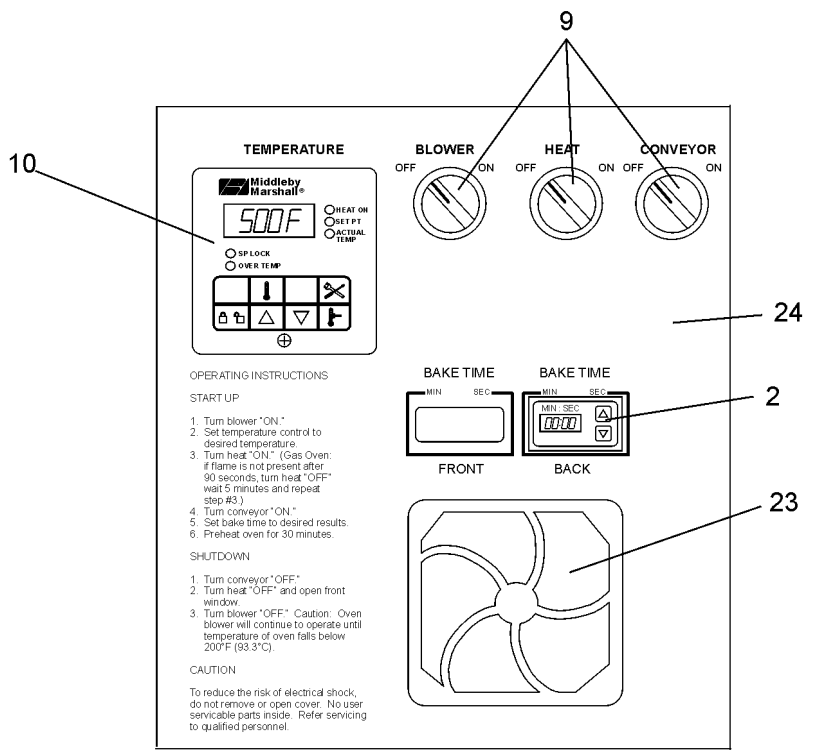

V. CONTROL PANEL AND MACHINERY COMPARTMENT

ITEM	QTY.	P/N	DESCRIPTION
1	1	37337	KIT, CONVEYOR SPEED CONTROL WITH DIGITAL DISPLAY
2	1	37503	DIGITAL DISPLAY ONLY
3a	1	35624	KIT, AIR SWITCH UPDATE - REPLACES 3a WITH 3b
3b	2	32102	AIR SWITCH, CURRENT
4	1	28021-0047	SWITCH, MACHINERY COMPARTMENT ACCESS PANEL SAFETY
5	3	27011-0011	TERMINAL BLOCK
6	2	27392-0002	COOLING (AXIAL) FAN
7	1	31651	AMPLIFIER BOARD (FOR OVENS WITH MODULATING GAS VALVES ONLY)
8	3	27060-0012	CONTACT BLOCK W/BASE
9	2	28021-0062	SELECTOR SWITCH - BLUE
10	1	36939	KIT, DIGITAL TEMPERATURE CONTROLLER
11	1	27170-0017	TRANSFORMER, BURNER 24V
12	1	36510	RELAY, BURNER MOTOR
13	1	42810-0114	KIT, IGNITION MODULE WITH ADAPTER
14	1	37210-0025	FRONT CONTROL DOOR PANEL
15a	1	36463	KIT, HIGH LIMIT UPDATE - REPLACES HIGH LIMIT USED TO 9/96 WITH 14b, 14c, AND 14d
15b	1	34982	HIGH LIMIT CONTROL (9/96-CURRENT)
15c	1	30693	RESET BUTTON, HIGH LIMIT CONTROL (9/96-CURRENT)
15d	1	35634	BRACKET, RESET BUTTON (9/96-CURRENT)

ITEM	QTY.	P/N	DESCRIPTION
16	1	27011-0013	TERMINAL BLOCK - CONVEYOR MOTOR
17	1	27030-0007	FUSE HOLDER, 1 POLE
18	1	28150-0135	FUSE, 1A-250V CLASS RK5
19	1	27021-0011	FUSE BLOCK, 30A-600V 5 POLE
20	4	28150-0048	FUSE, 15A-250V TIME DELAY
21	1	28154-0003	FUSE, 9A-250V TIME DELAY
22	1	28041-0008	CONTACTOR, 4 POLE
23a	2	22450-0258	FILTER AND COVER SET
23b	1	3102468	FILTER ONLY
24	1	22505-0065	FACE PLATE, CONTROL PANEL
--	--	31063	ASSY, LEFT WIRE HARNESS (LEFT MOTOR COMPARTMENT TO FRONT PANEL)
--	--	42410-0059	ASSY, RIGHT WIRE HARNESS (RIGHT MOTOR COMPARTMENT TO FRONT PANEL)
--	--	42410-0058	ASSY, FRONT WIRE HARNESS (MAIN HARNESS ACROSS FRONT PANEL)
--	--	35071	ASSY, WIRESET, THERMOCOUPLE AND SPEED SENSOR

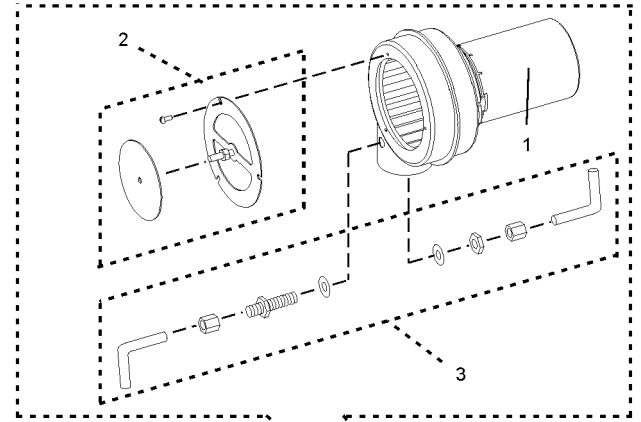
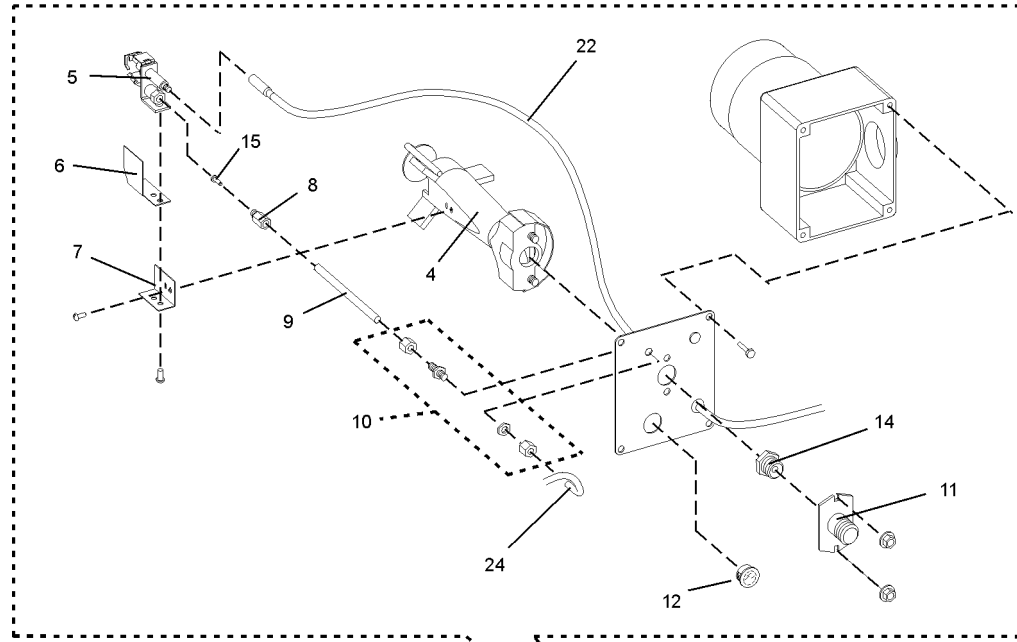

10

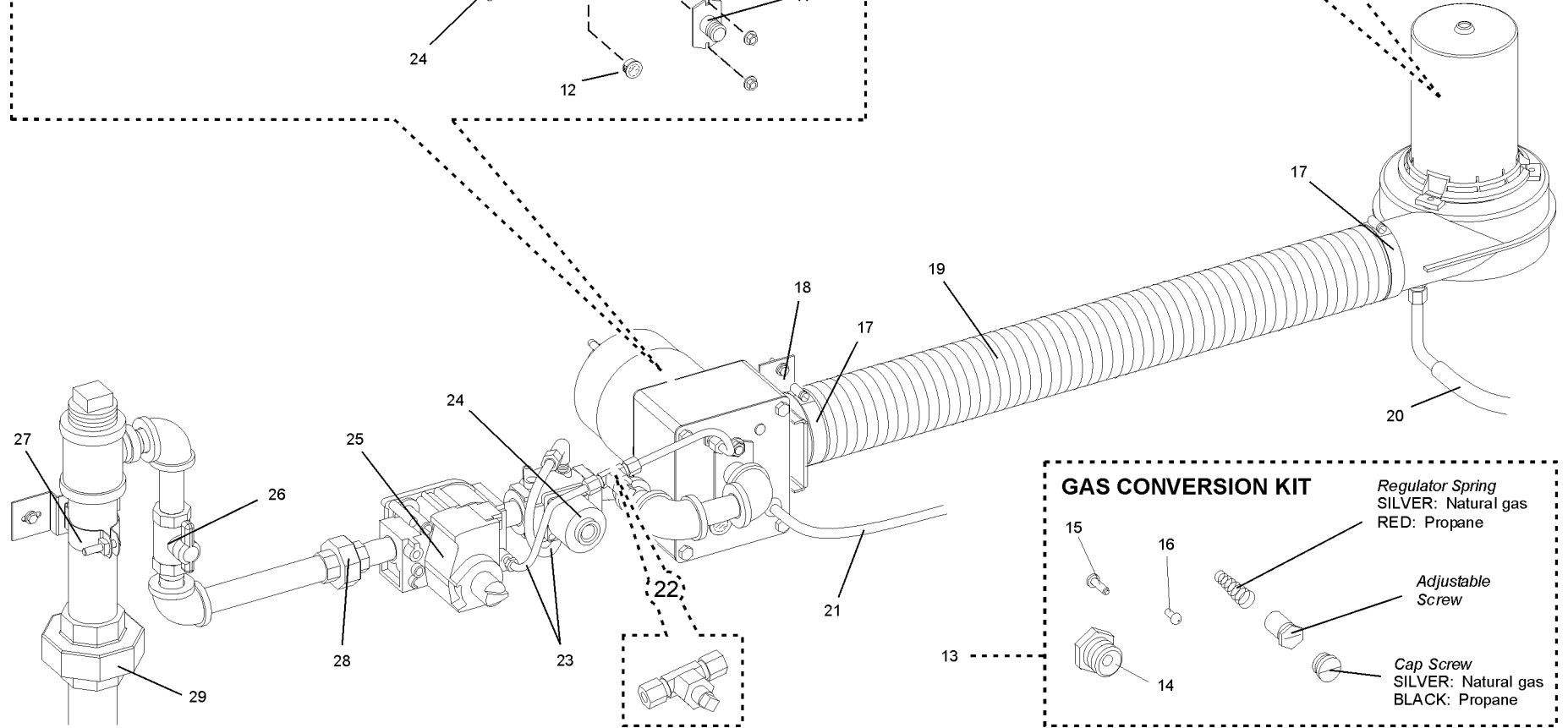

GAS CONVERSION KIT

- 15: Regulator Spring
SILVER: Natural gas
RED: Propane
- 16: Adjustable Screw
- 13: Cap Screw
SILVER: Natural gas
BLACK: Propane

VI. GAS BURNER SYSTEM - ORIGINAL CONFIGURATION (with solenoid valve)

ITEM	QTY.	P/N	DESCRIPTION
1	1	27170-0011	BLOWER AND MOTOR
2	1	42810-0087	KIT, EXTERNAL AIR SHUTTER
3	1	42400-0640	KIT, PITOT TUBE
4	1	27170-0223	VENTURI WITH TARGET
5	1	42810-0117	KIT, PILOT ASSEMBLY WITH IGNITOR
6	1	27170-0204	PILOT SHIELD
7	1	27170-0264	BRACKET, PILOT MOUNTING
8	1	38284	FITTING, PILOT TUBING
9	A/R	15125-0002	TUBING, ALUMINUM, 1/4"/6.4mm O.D.
10	1	36920	FITTING, BULKHEAD
11	1	38279	ORIFICE HOLDER/INLET CONNECTOR
12	1	38280	WINDOW PLUG
13a	--	42810-0127	KIT, PS570S GAS CONVERSION, PROPANE TO NATURAL GAS OPERATION (<i>INCLUDES ITEMS 14a, 15a, 16a, AND ALL PARTS AND INSTRUCTIONS FOR CONVERSION</i>)
14c	1	22176-0014	MAIN ORIFICE, NATURAL GAS, 0.250" (6.35mm)
15a	1	22174-0011	PILOT ORIFICE, NATURAL GAS, 0.028" (0.71mm)
16a	1	22174-0006	BYPASS ORIFICE, NATURAL GAS, 0.065" (1.65mm, #53 drill)

ITEM	QTY.	P/N	DESCRIPTION
13b	--	42810-0124	KIT, PS570S GAS CONVERSION, NATURAL GAS TO PROPANE OPERATION (<i>INCLUDES ITEMS 14b, 15b, 16b, AND ALL PARTS AND INSTRUCTIONS FOR CONVERSION</i>)
14b	1	22176-0015	MAIN ORIFICE, PROPANE, 0.152" (3.86mm)
15b	1	22174-0010	PILOT ORIFICE, PROPANE, 0.018" (0.46mm)
16b	1	22174-0009	BYPASS ORIFICE, PROPANE, 0.034" (0.86mm, #62 drill)
17	2	22450-0259	HOSE CLAMP
18	1	37210-0026	BRACKET, HOSE AND BURNER MOUNTING
19	1	22450-0255	AIR DUCT, FLEXIBLE
20	A/R	38290	TUBING, SILICONE RUBBER, 1/4"/6.4mm DIA.
21	1	27159-0019	IGNITION/SENSOR WIRE
22	1	30185	KIT, PILOT TEE 1/4"/6.4mm
23	A/R	15125-0002	TUBING, ALUMINUM, 1/4"/6.4mm O.D.
24	1	28091-0017	VALVE, SOLENOID, 1/2"
25	1	42810-0121	KIT, COMBINATION GAS VALVE (SAFETY REGULATOR), 1/2"
26	1	23115-0009	VALVE, SHUTOFF 1/2"
27	1	41649	BRACKET, PIPE MOUNTING 1-1/4"
28	1	23051-0003	UNION, PIPE 1/2"
29	1	23051-0012	UNION, PIPE 1-1/4"

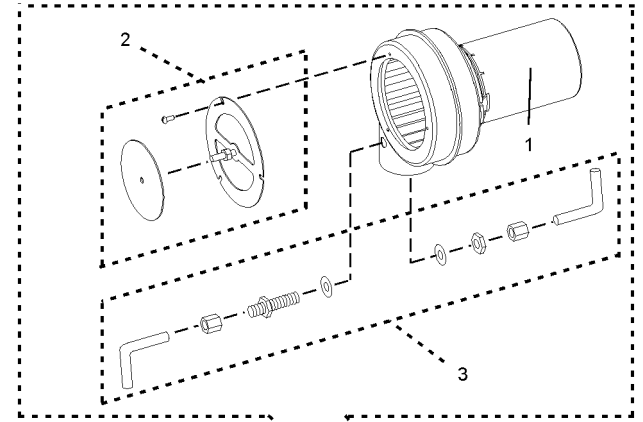
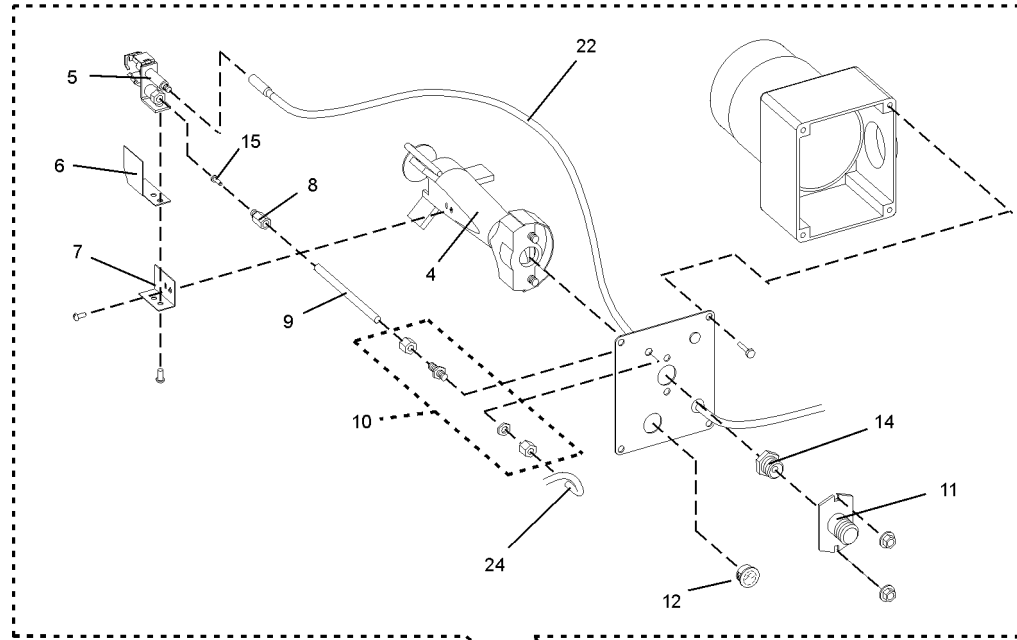

12

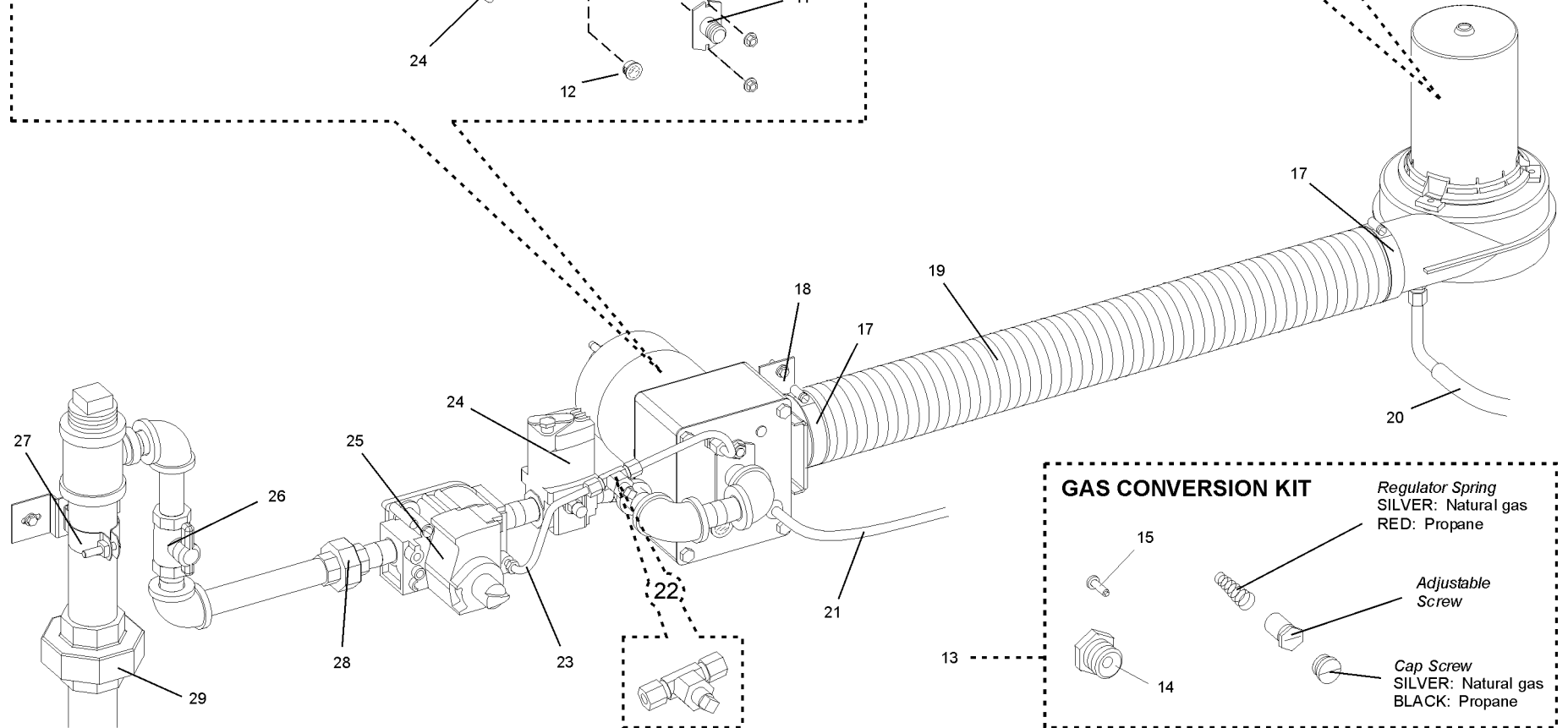

GAS CONVERSION KIT

- 15 Regulator Spring
SILVER: Natural gas
RED: Propane
- Adjustable Screw
- 14 Cap Screw
SILVER: Natural gas
BLACK: Propane

VI. GAS BURNER SYSTEM - CURRENT CONFIGURATION (with modulating valve)

ITEM	QTY.	P/N	DESCRIPTION
1	1	27170-0011	BLOWER AND MOTOR
2	1	42810-0087	KIT, EXTERNAL AIR SHUTTER
3	1	42400-0640	KIT, PITOT TUBE
4	1	27170-0223	VENTURI WITH TARGET
5	1	42810-0117	KIT, PILOT ASSEMBLY WITH IGNITOR
6	1	27170-0204	PILOT SHIELD
7	1	27170-0264	BRACKET, PILOT MOUNTING
8	1	38284	FITTING, PILOT TUBING
9	A/R	15125-0002	TUBING, ALUMINUM, 1/4"/6.4mm O.D.
10	1	36920	FITTING, BULKHEAD
11	1	38279	ORIFICE HOLDER/INLET CONNECTOR
12	1	38280	WINDOW PLUG
13a	--	42810-0127	KIT, PS570S GAS CONVERSION, PROPANE TO NATURAL GAS OPERATION (<i>INCLUDES ITEMS 14a, 15a, AND ALL PARTS AND INSTRUCTIONS FOR CONVERSION</i>)
14c	1	22176-0014	MAIN ORIFICE, NATURAL GAS, 0.250" (6.35mm)
15a	1	22174-0011	PILOT ORIFICE, NATURAL GAS, 0.028" (0.71mm)

ITEM	QTY.	P/N	DESCRIPTION
13b	--	42810-0124	KIT, PS570S GAS CONVERSION, NATURAL GAS TO PROPANE OPERATION (<i>INCLUDES ITEMS 14b, 15b, AND ALL PARTS AND INSTRUCTIONS FOR CONVERSION</i>)
14b	1	22176-0015	MAIN ORIFICE, PROPANE, 0.152" (3.86mm)
15b	1	22174-0010	PILOT ORIFICE, PROPANE, 0.018" (0.46mm)
17	2	22450-0259	HOSE CLAMP
18	1	37210-0026	BRACKET, HOSE AND BURNER MOUNTING
19	1	22450-0255	AIR DUCT, FLEXIBLE
20	A/R	38290	TUBING, SILICONE RUBBER, 1/4"/6.4mm DIA.
21	1	27159-0019	IGNITION/SENSOR WIRE
22	1	30185	KIT, PILOT TEE 1/4"/6.4mm
23	A/R	15125-0002	TUBING, ALUMINUM, 1/4"/6.4mm O.D.
24	1	41647	VALVE, MODULATING GAS, 1/2", M420
25	1	42810-0121	KIT, COMBINATION GAS VALVE (SAFETY REGULATOR), 1/2"
26	1	23115-0009	VALVE, SHUTOFF 1/2"
27	1	41649	BRACKET, PIPE MOUNTING 1-1/4"
28	1	23051-0003	UNION, PIPE 1/2"
29	1	23051-0012	UNION, PIPE 1-1/4"

13

NOTE: Ovens equipped with a belt tensioning pulley assembly must be updated before installing the parts listed below. Order Service Kit P/N 42811-0003 to update one oven cavity (idler and drive ends).

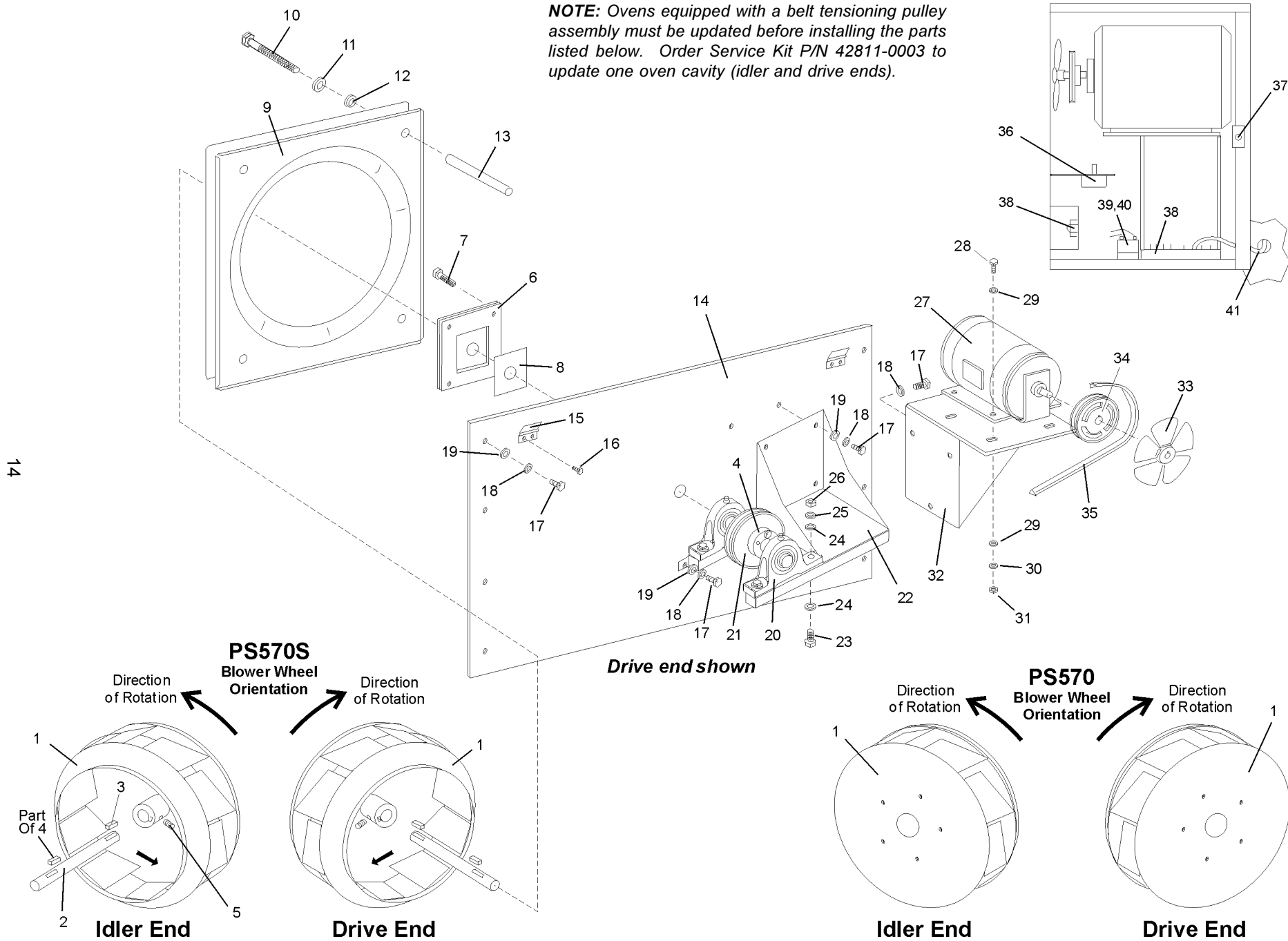

14

VII. BLOWER/MOTOR ASSEMBLIES (DRIVE AND IDLER)

ITEM	QTY.	P/N, PS570S	P/N, PS570	DESCRIPTION
1a	1	22521-0005	22521-0006	BLOWER WHEEL - CCW, DRIVE END
1b	1	22521-0006	22521-0005	BLOWER WHEEL - CW, IDLER END
2	1	35210-0506	N/A	BLOWER SHAFT, 1-7/16"/37mm DIA.
2	1	N/A	35210-0251	BLOWER SHAFT, 1"/25mm DIA.
3	1	35210-0286	35210-0286	KEY
4	1	22031-0018	N/A	BUSHING, SPLIT (INC. 2 BOLTS & KEY)
5	1	21265-0014	21265-0014	SET SCREW
6	1	37210-0101	37115-0151	SHAFT SEAL WELDMENT
7	4	21292-0001	21292-0001	SCREW, HEX WSHR HD #10-16 X 3/4"
8	1	35210-0541	35210-0217	SHAFT SEAL - TEFLON
9	1	37210-0124	N/A	WELDMENT, ORIFICE RING PLATE
10	4	21211-0001	N/A	SCREW, HEX 3/8"-16 X 3"
11	4	21422-0001	N/A	LOCK WASHER, 3/8"
12	4	21416-0001	N/A	FLAT WASHER, 3/8"
13	4	35210-0576	N/A	SPACER
14	1	37210-0126	37210-0036	BACK WALL
15	2	35000-1622	35000-1622	HANGER, REAR SHROUD
16	4	21292-0001	21292-0001	SCREW, TEC, #10-16 X 3/4"
17	16	21216-0001	21216-0001	BOLT, HEX HEAD, 3/8"-16 X 1"
18	16	21422-0001	21422-0001	LOCKWASHER, SPLIT, 3/8"
19	13	21416-0001	21416-0001	FLAT WASHER, 3/8"
20	2	22072-0017	22072-0026	BEARING
21	1	22230-0087	22230-0084	PULLEY/SHEAVE, 4.45"/113mm O.D.
22a	1	37210-0125	37210-0043	BRACKET, BEARING, DRIVE END
22b	1	37210-0131	37210-0039	BRACKET, BEARING, IDLER END
23	4	21322-0014	21322-0014	BOLT, 1/2"-13 X 3-1/2"
24	8	21461-0002	21461-0002	FLAT WASHER, 1/2"
25	4	21422-0016	21422-0016	LOCKWASHER, 1/2"

ITEM	QTY.	P/N, PS570S	P/N, PS570	DESCRIPTION
26	4	21162-0004	21162-0004	HEX NUT, 1/2"
27	1	27381-0069	27381-0069	MOTOR, 1 HP, 208/240V, 1PH, 50/60HZ
28	4	21214-0005	21214-0005	BOLT, HEX HEAD, 5/16"-18 X 1"
29	8	21412-0001	21412-0001	FLAT WASHER, 5/16"
30	4	21421-0004	21421-0004	LOCKWASHER, SPLIT, 5/16"
31	4	21126-0004	21126-0004	HEX NUT, 5/16"-18
32a	1	37210-0487	37210-0487	BRACKET, MOTOR MTG, DRIVE END
32b	1	37210-0488	37210-0488	BRACKET, MOTOR MTG, IDLER END
33a	1	27399-0009	27399-0009	FAN BLADE-CW, DRIVE END OF OVEN
33b	1	27399-0008	27399-0008	FAN BLADE-CW, IDLER END OF OVEN
34a	1	-	NOT AVAILABLE USE 34b	PULLEY, BK39 3.5"/89mm (PS570)
34b	1	22230-0086	-	PULLEY, BK55 5.25"/133mm (PS570S, PHI AND 50Hz OVENS)
34c	1	30476	-	PULLEY, BK47 4.45"/113mm (PS570S, STANDARD)
34d	1	39910	-	PULLEY, BK62 (PS570S, HI-ALTITUDE)
35a	1	-	22181-0037	BELT, BLOWER (PS570)
35b	1	22181-0040	-	BELT, BLOWER B56 (PS570S)
35c	1	30674	-	BELT, BLOWER B55 (PS570S)
35d	1	39911	-	BELT, BLOWER B58 (PS570S HI-ALT)
36	1	28021-0061	28021-0061	SWITCH, MOMENTARY (BLACK)
37	1	28021-0047	28021-0047	SWITCH, INTERLOCK (WHITE)
38	2	27011-0011	27011-0011	TERMINAL BLOCK, 600V 30A 8-POLE
39	1	27170-0269	27170-0269	CAPACITOR, START (BLACK)
40	1	27170-0270	27170-0270	CAPACITOR, RUN (SILVER)
41	1	33984	33984	THERMOCOUPLE
-	1	N/A	22420-0002	GASKET, 89"/2.26m, BACK WALL
-	-	39909	-	KIT, PS570S HI-ALTITUDE CONVERSION

15

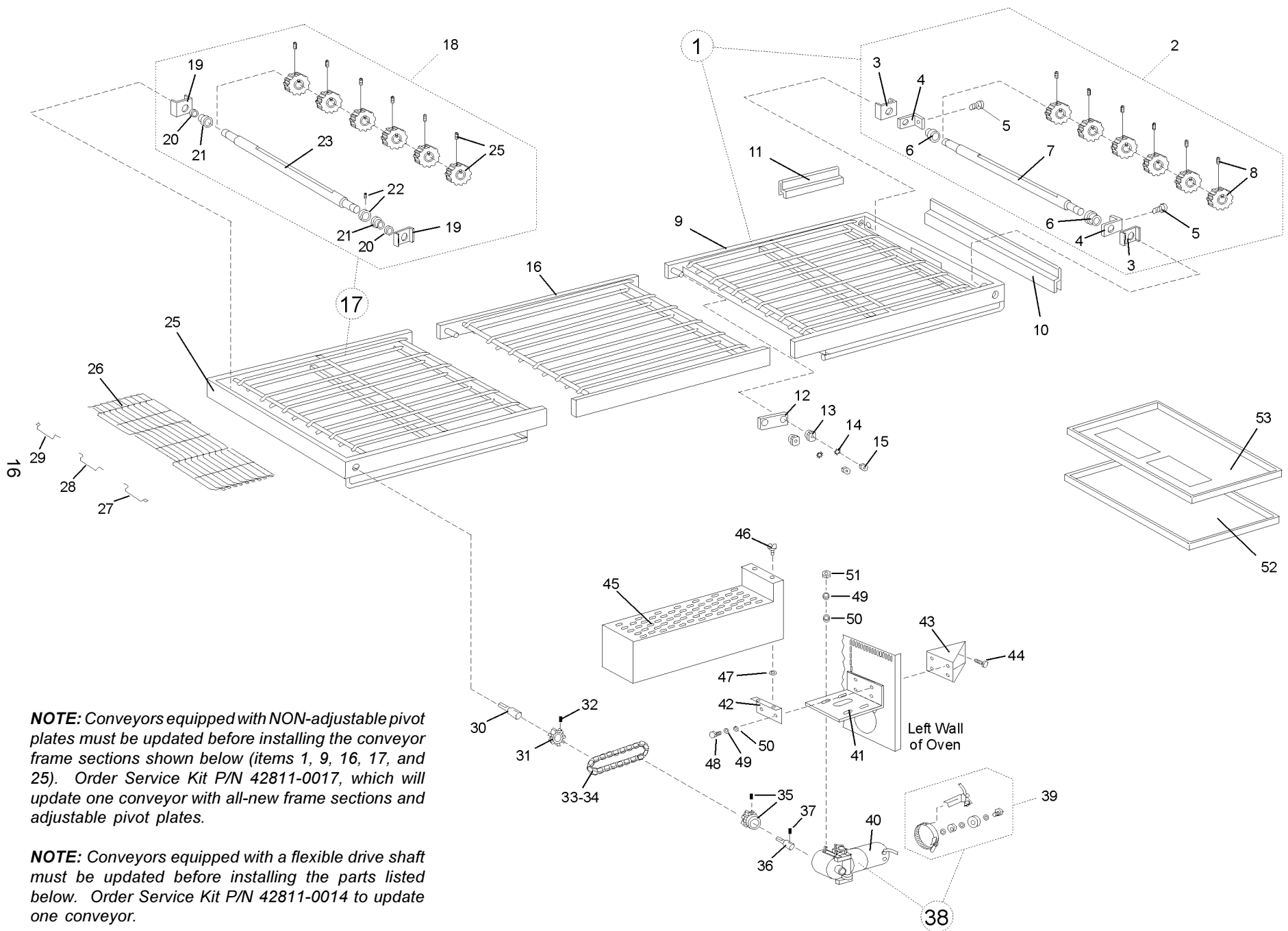

NOTE: Conveyors equipped with NON-adjustable pivot plates must be updated before installing the conveyor frame sections shown below (items 1, 9, 16, 17, and 25). Order Service Kit P/N 42811-0017, which will update one conveyor with all-new frame sections and adjustable pivot plates.

NOTE: Conveyors equipped with a flexible drive shaft must be updated before installing the parts listed below. Order Service Kit P/N 42811-0014 to update one conveyor.

VIII. CONVEYOR - SINGLE-BELT OVENS

ITEM	QTY.	P/N	DESCRIPTION
-	1	42410-0138	ASSY, CONVEYOR COMPLETE - INC. FRAME, BELT AND SHAFTS
1	1	42410-0142	IDLER FRAME ASSEMBLY - INCLUDES ITEMS 2-9
2	1	49400-0014	IDLER SHAFT ASSEMBLY - INCLUDES ITEMS 3-8
3	2	35900-0020	BRACKET, CONVEYOR SHAFT SUPPORT
4	2	37000-0413	BRACKET, IDLER SHAFT ADJUSTMENT
5	2	35000-1008	BOLT, TENSION ADJUSTMENT
6	2	22034-0003	BUSHING
7	1	35000-1011	IDLER SHAFT
8	6	22229-0003	CONVEYOR SPROCKET WITH SET SCREW
-	-	21276-0039	SET SCREW, CONV. SPROCKET, 1/4"-28 X 3/8"
9	1	37210-0116	FRAME, IDLER
10	1	35000-1103	CONVEYOR END STOP
11	1	35900-0148	CONVEYOR REAR STOP
12a	4	35210-0429	PIVOT PLATE (FOR CONVEYORS WITH ADJUSTABLE PIVOT PLATES)
17	12b	NOT AVAILABLE UPDATE WITH KIT 42811-0017	PIVOT PLATE, (FOR CONVEYORS WITH NON-ADJUSTABLE PIVOT PLATES)
13	8	35210-0491	BUSHING, CONVEYOR ADJUSTMENT
14	8	F716A8805	WASHER, EXTERNAL TOOTH
15	8	21176-0001	LOCKNUT, HEX, 1/4"-20
16	1	37210-0046	FRAME, CENTER
17	1	42410-0141	DRIVE FRAME ASSEMBLY - INC. ITEMS 18-25
18	1	49400-0012	DRIVE SHAFT ASSEMBLY - INC. ITEMS 19-24
19	2	35900-0020	BRACKET, CONVEYOR SHAFT SUPPORT
20	2	35000-1080	NYLON SPACER
21	2	22034-0003	BUSHING
22	1	22011-0013	COLLAR WITH SET SCREW
23	1	35000-1012	DRIVE SHAFT
24	6	22229-0003	CONVEYOR SPROCKET WITH SET SCREW
-	-	21276-0039	SET SCREW, CONV. SPROCKET, 1/4"-28 X 3/8"
25	1	37210-0117	FRAME, DRIVE
26a	1	22450-0265	CONVEYOR BELT, COMPLETE, 32" X 204" (0.81 X 5.18m)
26b	-	33900-0032	CONVEYOR BELT, 32 X 12" (0.81 X 0.30m)

ITEM	QTY.	P/N	DESCRIPTION
-	1	42400-0089	KIT, MASTER LINKS, 32" (0.81m) BELT (INC. ITEMS 27-29)
27	1	-	MASTER LINK, RIGHT
28	4	-	MASTER LINK, MIDDLE
29	1	-	MASTER LINK, LEFT
30	1	35000-1013	DRIVE SHAFT ADAPTOR
31	1	22152-0017	SPROCKET, 40 CHAIN, 9T, 5/8" BORE
32	1	21276-0038	SET SCREW 10-24 x 5/16
33	1	42400-0164	DRIVE CHAIN (62 LINKS)
34	1	22273-0001	MASTER LINK, DRIVE CHAIN
35	1	22152-0018	SPROCKET, 40 CHAIN, 15 T, 5/8" BORE
36	1	35210-0640	ADAPTER, GEAR MOTOR #10-32 X 5/16"
37	1	21276-0041	SET SCREW
38	1	42400-0414	ASSEMBLY, DRIVE MOTOR WITH PICK UP
39	1	27170-0263	PICK UP ASSEMBLY
40	1	27384-0008	DRIVE MOTOR
-	2	22450-0052	BRUSHES, DRIVE MOTOR
41	1	37210-0097S	WELDMENT, MOTOR MOUNTING
42	1	37210-0099	WELDMENT, SUPPORT BRACKET
43	1	37210-0098	WELDMENT, MOTOR MOUNTING SUPPORT
44	1	21292-0001	SCREW, HEX, WSHR HD #2PT 10-16 x 3/4"
45	1	37210-0096	WELDMENT, CHAIN COVER
46	2	21296-0002	WING SCREW
47	2	21182-0007	NUT, GRIP
48	4	A3333	SCREW, HEX CAP 1/4"-20 x 3/4"
49	8	21426-0002	LOCKWASHER, 1/4"
50	8	21411-0003	FLATWASHER
51	4	21126-0009	HEX NUT 1/4-20
52a	2	30003	CRUMB PAN, ALUMINIZED (WITHOUT OPENINGS - FOR LOWER OVEN CAVITY ONLY)
52b	2	35210-0262	CRUMB PAN, STAINLESS STEEL (WITHOUT OPENINGS - FOR LOWER OVEN CAVITY ONLY)
53a	2	30004	CRUMB PAN, ALUMINIZED (WITH OPENINGS - FOR ALL UPPER OVEN CAVITIES)
53b	2	35210-0179	CRUMB PAN, STAINLESS STEEL (WITH OPENINGS - FOR ALL UPPER OVEN CAVITIES)

PS570&PS570S
USA & Std. Export

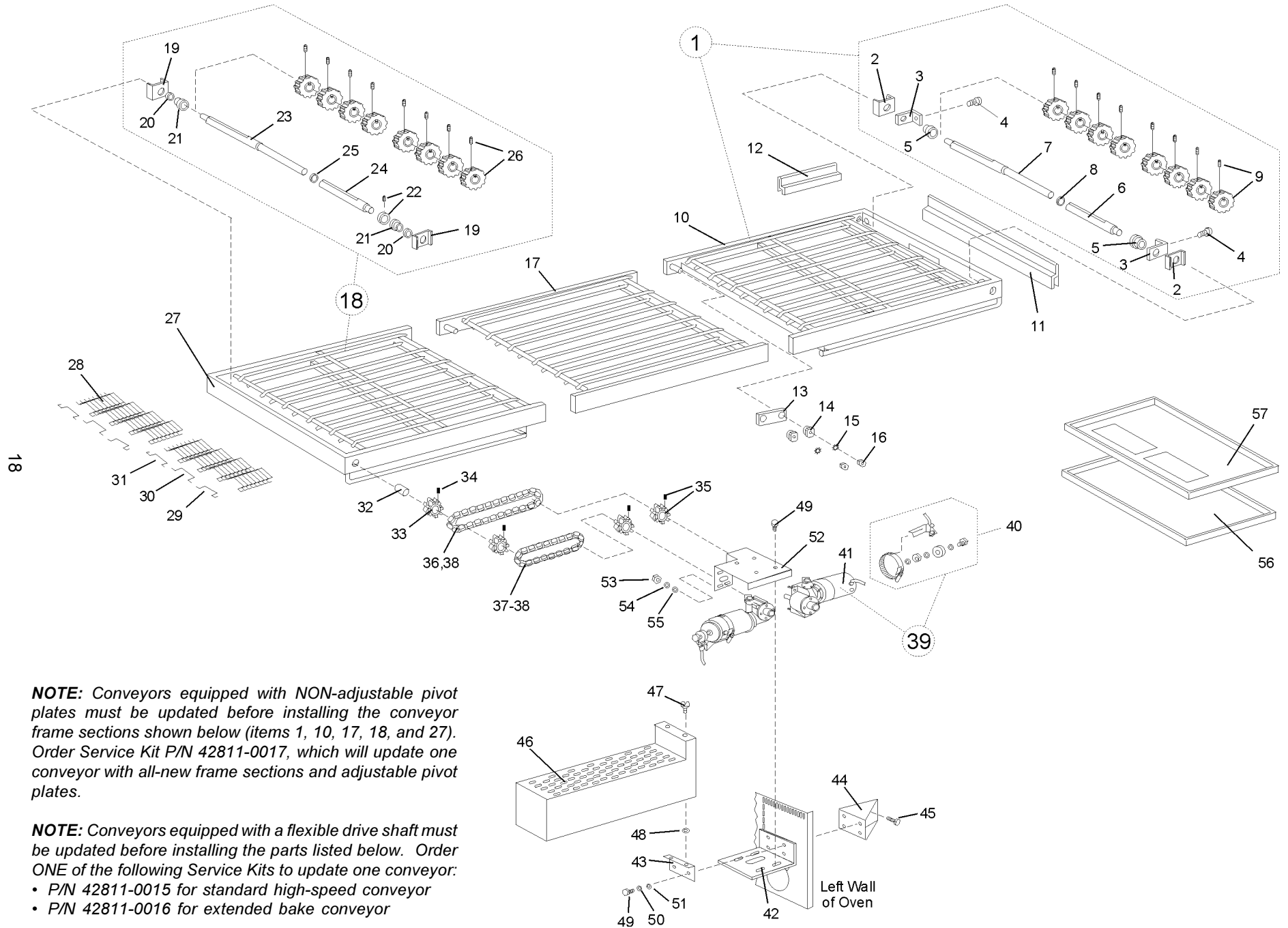

NOTE: Conveyors equipped with NON-adjustable pivot plates must be updated before installing the conveyor frame sections shown below (items 1, 10, 17, 18, and 27). Order Service Kit P/N 42811-0017, which will update one conveyor with all-new frame sections and adjustable pivot plates.

NOTE: Conveyors equipped with a flexible drive shaft must be updated before installing the parts listed below. Order ONE of the following Service Kits to update one conveyor:

- P/N 42811-0015 for standard high-speed conveyor
- P/N 42811-0016 for extended bake conveyor

IX. CONVEYOR - SPLIT-BELT OVENS

ITEM	QTY.	P/N	DESCRIPTION
--	--	35614	KIT, SINGLE BELT TO SPLIT BELT CONVEYOR CONVERSION
1	1	42410-0156	IDLER FRAME ASSEMBLY - INC. ITEMS 2-10
2	2	35900-0020	BRACKET, CONVEYOR SHAFT SUPPORT
3	2	37000-0413	BRACKET, IDLER SHAFT ADJUSTMENT
4	2	35000-1008	BOLT, TENSION ADJUSTMENT
5	2	22034-0003	BUSHING
6	1	35000-1535	IDLER SHAFT, FRONT
7	1	42400-0354	IDLER SHAFT, REAR
8	1	21415-0001	FLAT WASHER, BRONZE
9	8	22229-0003	CONVEYOR SPROCKET WITH SET SCREW
--	8	21276-0039	SET SCREW, CONV. SPROCKET, 1/4"-28 X 3/8"
10	1	37210-0116	FRAME, IDLER
11	1	35000-1103	CONVEYOR END STOP
12	1	35900-0148	CONVEYOR REAR STOP
13a	4	35210-0429	PIVOT PLATE (FOR CONVEYORS WITH ADJUSTABLE PIVOT PLATES)
13b	4	35900-0170	PIVOT PLATE, (FOR CONVEYORS WITH NON-ADJUSTABLE PIVOT PLATES)
14	8	35210-0491	BUSHING, CONVEYOR ADJUSTMENT
15	8	F716A8805	WASHER, EXTERNAL TOOTH
16	8	21176-0001	LOCKNUT, HEX, 1/4" X 20
17	1	37210-0046	FRAME, CENTER
18	1	42410-0157	DRIVE FRAME ASSEMBLY - INC. ITEMS 19-27
19	2	35900-0020	BRACKET, CONVEYOR SHAFT SUPPORT
20	2	35000-1080	SPACER, NYLON
21	2	22034-0003	BUSHING, 5/8" ID X 3/4" OD X 1/2" L
22	1	22011-0014	SPLIT LOCKING COLLAR
23	1	42400-0355	DRIVE SHAFT, REAR
24	1	35000-1536	DRIVE SHAFT, FRONT
25	1	21415-0001	FLAT WASHER, BRONZE
26	8	22229-0003	CONVEYOR SPROCKET WITH SET SCREW
--	8	21276-0039	SET SCREW, CONV. SPROCKET, 1/4"-28 X 3/8"
27	1	37210-0117	FRAME, DRIVE
28a	2	22450-0271	CONVEYOR BELT, COMPLETE, 15x204" / 0.38x5.18m
28b	--	33900-0037	CONVEYOR BELT, 15 X 12" (0.38 X 0.30m)
29	2	NOT AVAILABLE	MASTER LINK, RIGHT
30	2	NOT AVAILABLE	MASTER LINK, MIDDLE
31	2	NOT AVAILABLE	MASTER LINK, LEFT

19

ITEM	QTY.	P/N	DESCRIPTION
32	1	35000-1537	BUSHING, DRIVE SPROCKET
33	2	22152-0017	SPROCKET, 40 CHAIN, 9T, 5/8" BORE
34	2	21276-0049	SET SCREW 10-24 X 1/2"
35	2	22152-0024	SPROCKET, 40 CHAIN, 15T, 5/8" BORE
36	1	42400-0164	DRIVE CHAIN, 62 LINKS
37	1	42410-0128	DRIVE CHAIN, 48 LINKS
38	2	22273-0001	MASTER LINK, DRIVE CHAIN
39a	2	42410-0158	ASSEMBLY, DRIVE MOTOR WITH PICKUP, 311:1 STANDARD HIGH SPEED - INC. ITEMS 41a-42a
40a	2	27170-0263	PICK UP ASSEMBLY ONLY
41a	2	27384-0014	DRIVE MOTOR, 311:1
--	2	22450-0230	BRUSHES, DRIVE MOTOR
39b	2	42410-0159	ASSEMBLY, DRIVE MOTOR WITH PICKUP, 1350:1 EXTENDED BAKE - INC. ITEMS 41b-42b
40b	2	27170-0263	PICK UP ASSEMBLY ONLY
41b	2	27384-0011	DRIVE MOTOR, 1350:1
--	2	22450-0230	BRUSHES, DRIVE MOTOR
42	1	37210-0097S	WELDMENT, MOTOR MOUNTING
43	1	37210-0099	WELDMENT, SUPPORT BRACKET
44	1	37210-0098	WELDMENT, MOTOR MOUNTING SUPPORT
45	1	21292-0001	SCREW, HEX WSHR HD #2PT 10-16 X 3/4"
46	1	37210-0096	WELDMENT, CHAIN COVER
47	2	21296-0002	WING SCREW
48	2	21182-0007	NUT, GRIP
49	8	A3333	SCREW, HEX CAP 1/4"-20 X 3/4"
50	8	21426-0002	LOCKWASHER, 1/4"
51	4	21411-0003	FLATWASHER
52	1	37210-0100	WELDMENT, MOTOR MOUNTING, SPLIT BELT
53	8	F707A8803	HEX NUT, #10-32
54	8	21421-0011	LOCKWASHER, #10
55	8	21421-0003	FLATWASHER, #10
56a	2	30003	CRUMB PAN, ALUMINIZED (WITHOUT OPENINGS - FOR LOWER OVEN CAVITY ONLY)
56b	2	35210-0262	CRUMB PAN, STAINLESS STEEL (WITHOUT OPENINGS - FOR LOWER OVEN CAVITY ONLY)
57a	2	30004	CRUMB PAN, ALUMINIZED (WITH OPENINGS - FOR ALL UPPER OVEN CAVITIES)
57b	2	35210-0179	CRUMB PAN, STAINLESS STEEL (WITH OPENINGS - FOR ALL UPPER OVEN CAVITIES)

PS570 & PS570S
USA & Std. Export

WARNING

Improper installation, adjustment, alteration, service or maintenance can cause property damage, injury or death. Read the installation, operating and maintenance instructions thoroughly before installing or servicing this equipment.

NOTICE

During the warranty period, ALL parts replacement and servicing should be performed by your Middleby Marshall Authorized Service Agent. Service that is performed by parties other than your Middleby Marshall Authorized Service Agent may void your warranty.

NOTICE

Using any parts other than genuine Middleby Marshall factory manufactured parts relieves the manufacturer of all warranty and liability.

NOTICE

Middleby Marshall reserves the right to change specifications at any time.

**PS570 & PS570S
USA & Std. Export**

Middleby Cooking Systems Group • 1400 Toastmaster Drive • Elgin, IL 60120 • USA • (847)741-3300 • FAX (847)741-4406

24-Hour Service Hotline: 1-(800)-238-8444

www.middleby.com

