

Parts Manual

with Wiring Diagrams
for domestic ovens

For Production After April, 2007
XXXXXX0407

Serial # Code (Ten Digit Code)
First 5 digits - order of production
Sixth digit - model specific
Seventh and Eighth digit- month of production
Ninth and Tenth digit - year of production

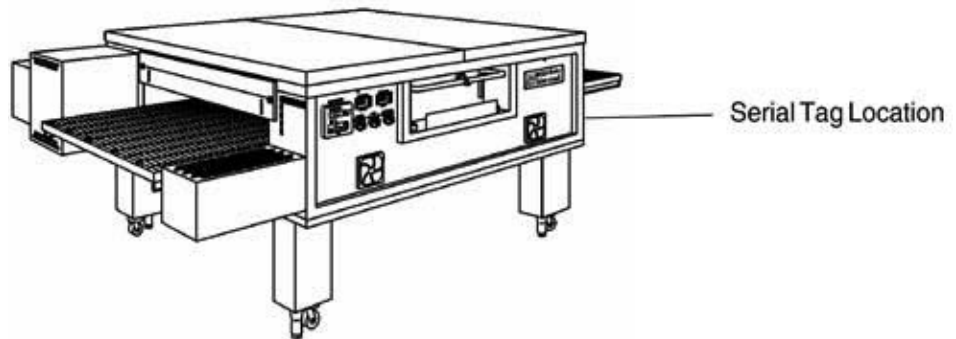

Table of Contents: Page 2



www.middleby.com
email: techsupport@middleby.com
1400 Toastmaster Drive
Elgin, IL 60120
1-847-741-3300 fax 1-847-741- 4406

Table of Contents

Spec Sheet	3
Key Parts	7
Cross Reference of Wiring Diagram Symbols and Part Number(s)	8
View of Installation Kit(s) and Base Kit(s)	9
Parts for Installation Kit(s) and Base Kit(s)	10
Standard Finger Configuration and Part Numbers 60188B	11
View of Oven Panels, End Plugs and Window	12
Parts for Oven Panels, End Plugs and Window	13
View of Gas Piping	14
Parts for Gas Piping	15
View(s) of Burner/Blower Motor Assembly	16
Parts for Burner/Blower Motor Assembly	17
View(s) of Front Control Area(s)	18
Parts for Front Control Area(s)	19
View of Rear Compartment and Blowers (Conveyor Drive End Shown)	20
Parts for Rear Compartment and Blowers (Conveyor Drive End Shown)	21
View of “Single” Belt Conveyor	22
Parts for “Single” Belt Conveyor	23
View of “Split” Belt Conveyor	24
Parts for “Split” Belt Conveyor	25
Wiring Diagram, G208-240, 50/60Hz, 1 Phase 54745 Rev. I	26



PATENTS PENDING

Principle

Middleby Marshall PS Series Conveyor ovens bake both faster and at a lower temperature than other ovens. Patented vertical columns of hot air move heat aerodynamically instead of using high temperatures. The streams of hot air remove the boundary layers of cool heavy air which tend to insulate the product. This gives very rapid baking without burning. All PS670WOW ovens are designed to cook pizza 30% faster than other conveyor ovens.

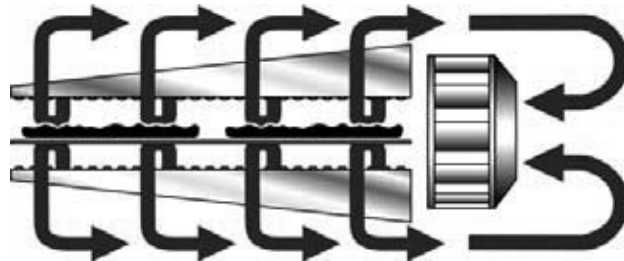

Standard Features

- **Impingement PLUS!** low oven profile and dual air return
- **Patented EMS Energy Management System** reduces gas consumption and increases cooking efficiency
- 70"/1778mm-long cooking chamber
- 32"/813mm-wide, 106"/2692mm-long conveyor belt

Speed

- Advanced technology air delivering system bakes up to 30% faster than standard conveyor ovens.

Energy Management System

* The PS670 features an Energy Management System (EMS) that automatically reduces gas consumption. Touch Screen Control can be programmed in one energy saving mode.

* Automatic "energy eye" saves gas when no pizza's are in the oven.

Cleanability

PS670 ovens are designed for easy cleaning. Removable parts include: crumb pans, end panels, air fingers, and a folding conveyor belt assembly.

Easily Serviced

Control compartment is designed for quick and easy access. All electrical controls are door-mounted.

Warranty

All PS670 models have a one year parts and labor warranty. Oven start-up and demonstration are included at no additional charge (USA only).

Ventilation

For installation under a ventilation hood only.



A MIDDLEBY COMPANY
1400 Toastmaster Drive
Elgin, Illinois 60120 USA
(847) 741-3300 Fax: (847) 741-0015
www.middleby.com

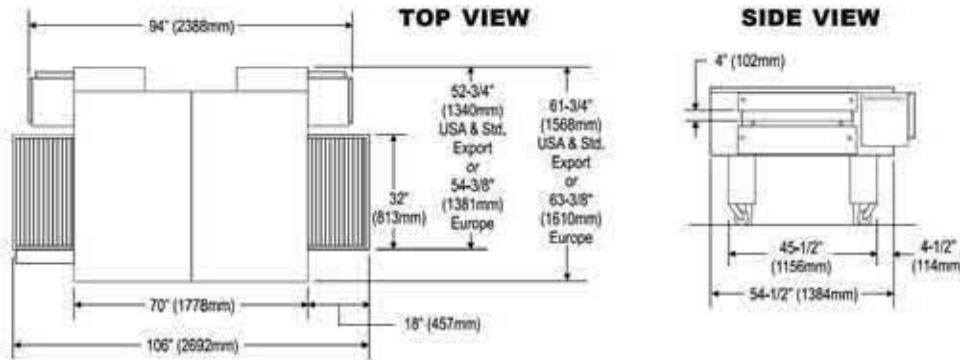

- ① Gas Utility Connection
- ② Electrical Utility Connection

**PS670-1 Single Oven
with 19" (483mm) leg extensions**

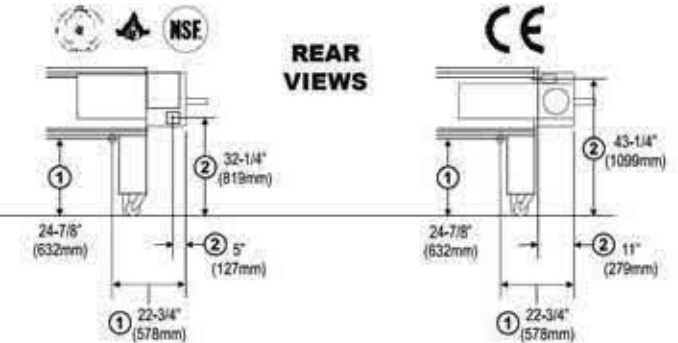
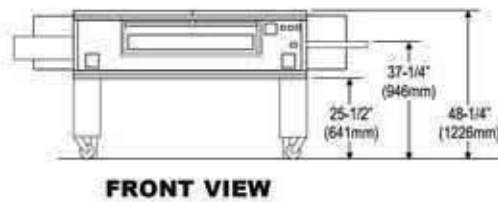

**PS670-2 Double Oven
with 10" (254mm) leg extensions**

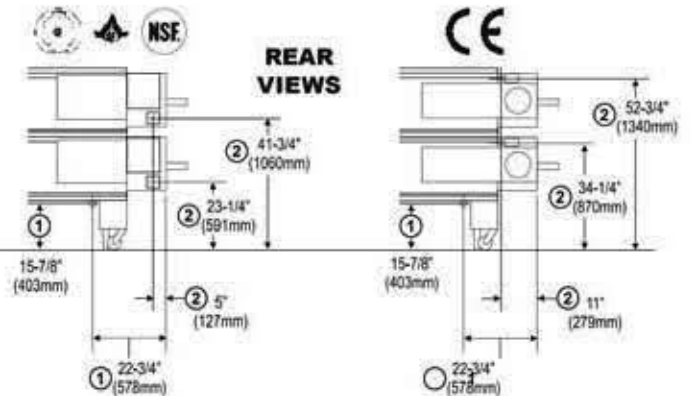
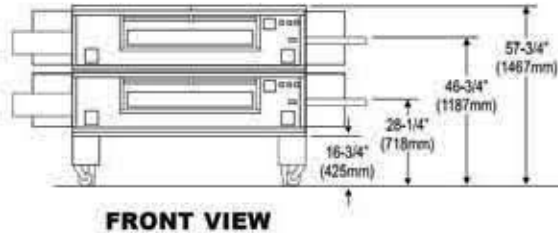

**PS670-2 Double Oven
with 15" (381mm) leg extensions**

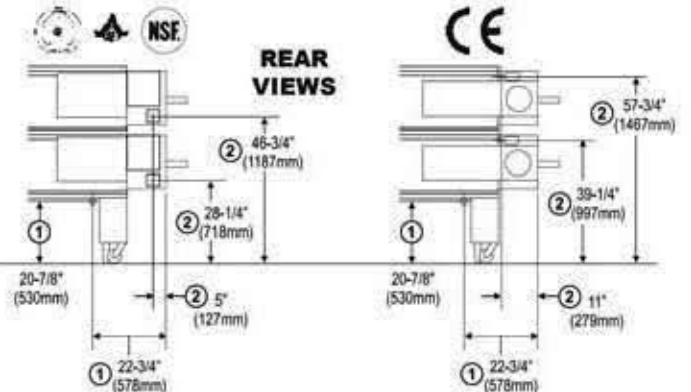
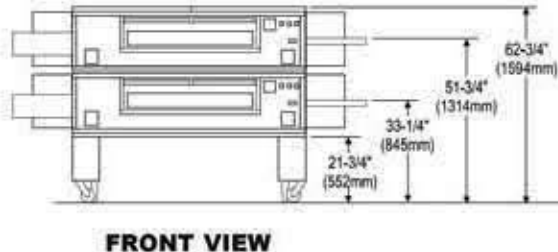

**PS670-3 Triple Oven
with 4" (102mm) leg extensions**

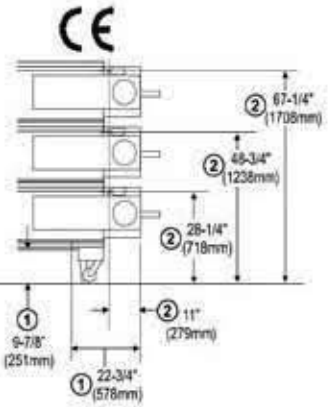
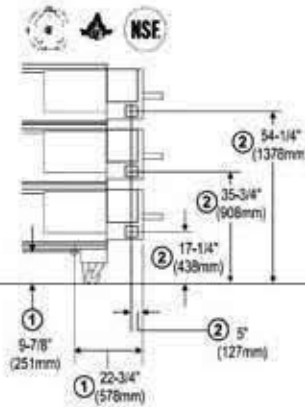
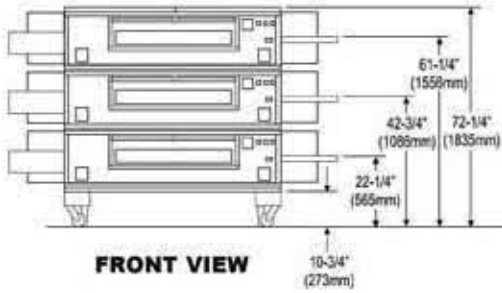

**PS670-3 Triple Oven
without leg extensions**

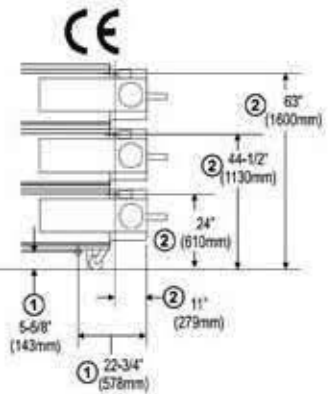
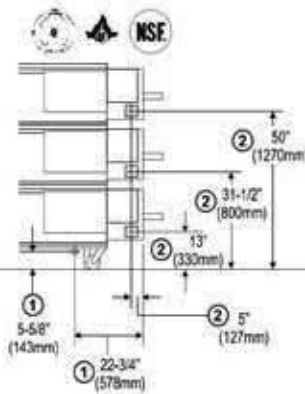
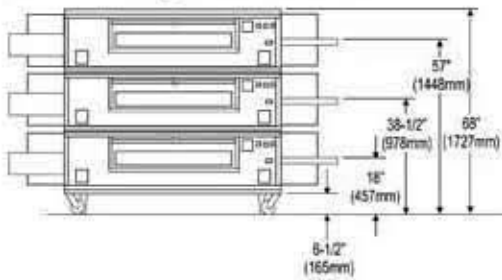



RECOMMENDED MINIMUM CLEARANCES

Rear of oven to wall	Right side of oven to wall	Left side of oven to wall
0" (0mm)	0" (0mm)	0" (0mm)

GENERAL INFORMATION

Model	Heating Zone	Baking Area	Belt Length	Belt Width	Oven Depth	Height	Max. Operating Temp.	Bake Time Range	Ship Wt.	Ship Cube
PS670-1 with 19" (483mm) leg extensions	70" 1778mm	15.5 sq. ft. 1.44m ²	106" 2692mm	32" 813mm	61-3/4" 1568mm	48-1/4" 1226mm	550°F 288°C	5:45 6:45	1750 lbs. 795kg	160 ft. ³ 4.5m ³
PS670-2 with 15" (381mm) leg extensions	140" 3556mm	31 sq. ft. 2.88m ²	106" 2692mm	32" 813mm	61-3/4" 1568mm	62-3/4" 1594mm	550°F 288°C	5:45 6:45	3500 lbs. 1589kg	320 ft. ³ 9.0m ³
PS670-3 with 4" (102mm) leg extensions	210" 5334mm	46.5 sq. ft. 4.32m ²	106" 2692mm	32" 813mm	61-3/4" 1568mm	72-1/4" 1835mm	550°F 288°C	5:45 6:45	5250 lbs. 2384kg	480 ft. ³ 13.5m ³

ELECTRICAL SPECIFICATIONS

Model	Version	Voltage	Phase/Freq.	Supply
PS670	 	208-240V	1/60 Hz	3 pole, 3 wire (2 hot, 1 grd)

The average current draw during operation is significantly lower.

Max Current Draw at Startup

Amps
20A*

Breakers

As per
local codes

GAS SUPPLY SPECIFICATIONS

	Min. Gas Pipe Size	Supply Gas Pressure	Rated Heat Input
Natural Gas	2" (50.8mm) main One 1-1/4" (12.7mm) NPT branch to lower oven cavity with individual full-flow shutoff valve	6-12" W.C. (14.9-29.9 mbar)	175,000 BTU (44.1 kcal, 51.3 kW/hr.) per oven cavity
Propane Gas	2" (50.8mm) main One 1-1/4" (12.7mm) NPT branch to lower oven cavity with individual full-flow shutoff valve	11-14" W.C. (27.4-34.9 mbar)	175,000 BTU (44.1 kcal, 51.3 kW/hr.) per oven cavity

* The gas supply pressures shown are for ovens installed in North America. The required gas supply pressures of other locations are dependent on the local gas type and on all applicable local codes.

ALL SPECIFICATIONS SUBJECT TO CHANGE WITHOUT NOTICE.

KEY PARTS

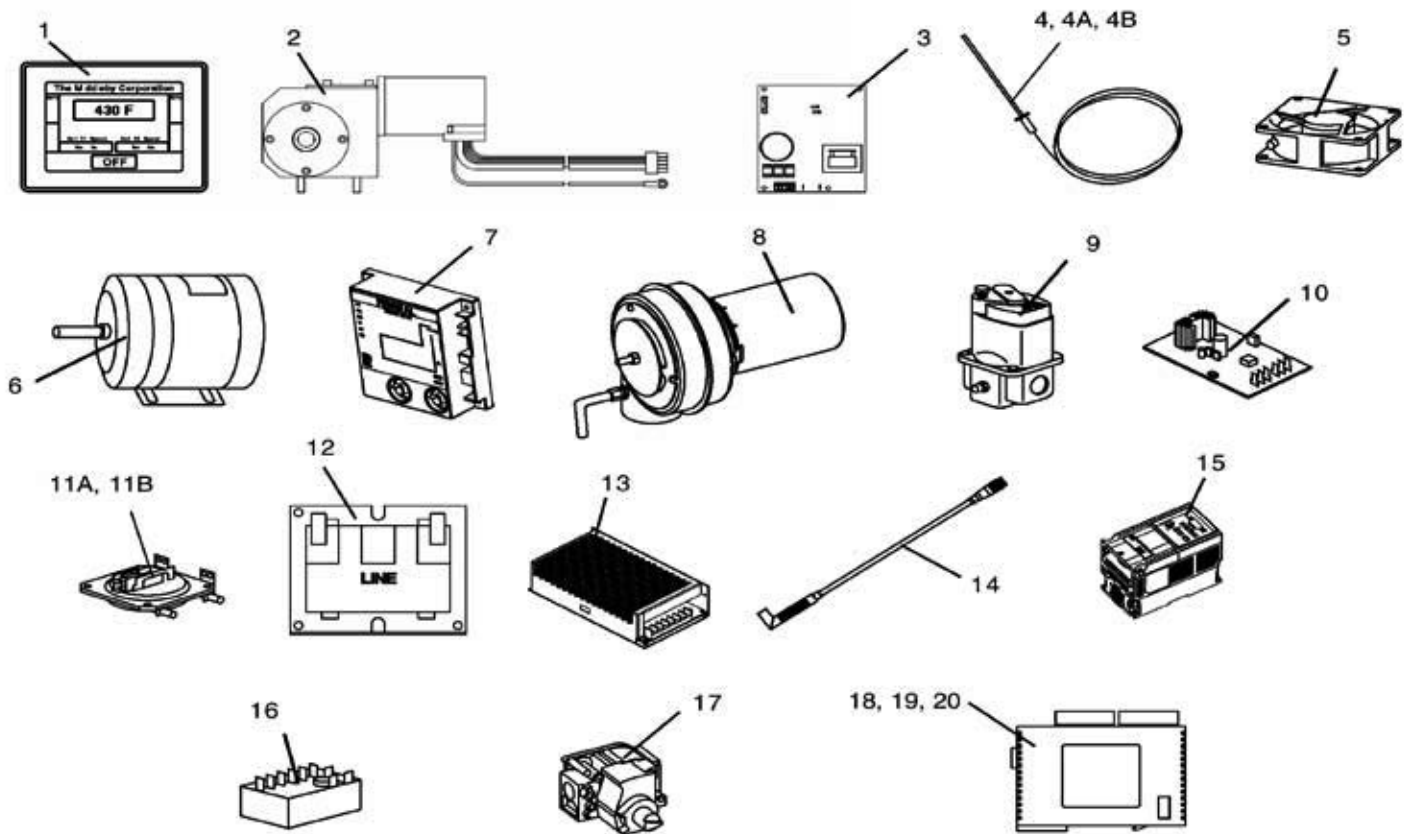

ITEM	PART NO.	DESCRIPTION	QUANTITY
1	60088	Display, Touch Screen- Programmed	1
2	58678	Drive Motor, Conveyor, 1400:1, 130VDC	1 or 2
3	58679	Controller, Conveyor	1 or 2
4	33812-6	Thermocouple, 12" Temp. Control	4
4A	33812-8	Thermocouple, 2.5" Control Compartment	1
4B	33812-1	Thermocouple, 6" High Limit (33984)	1
5	M9616	Cooling Fan, 6", 24VDC	2
6	57288	Blower Motor, 2 hp, 1725 RPM	2
7	54727	Ignition Module, Dual	1
8	M9887	Burner/Blower Motor, 24VDC	1
9	59450	Modulating Gas Valve, 1/2"(41647)	2
10	31651	Amplifier Board	2
11A	50610	Air Switch, Rear Blower	2
11B	57141	Air Switch, Burner/Blower Motor, Front	1
12	32108	Transformer, 240V/24V, 65VA	2
13	M9608	Power Supply, 24VDC	1
14	59112	Photocell	1
15	60126	Invertor, 2 hp-Programmed	2
16	33983	Hi Limit Control Module	1
17	54724	Gas Valve, Main, 1/2" Natural Gas	1
18	60128	Control Module, Digital, C14RS, Left	1
19	58668	Thermocouple Module, Digital, TC4, Middle	1
20	58669	Converter Module, Digital, A041, Right	1
21	58833	Flame Sensor	2
22	58834	Ignitor	2
23	58676	Control Cable-Touch Screen Display to PLC	1
24	59132	Relay-Glass	1
25	58777	Blower Belt	2

CROSS REFERENCE of WIRING DIAGRAM SYMBOLS and PART NUMBERS

• Air Switch 1 -Rear Right.....	50610	• Ignition Module, Dual	54727
• Air Switch 2 - Rear Left	50610	• Inverter - 1 Left, 2HP	60126
• Air Switch 3 - Front Right	57141	• Inverter - 2 right, 2 HP	60126
• Blower Motor–Left	57288	• Switch(es)	
• Blower Motor–Right.....	57288	• LS1 (LH RR), Momentary.....	28021-0061
• Burner Blower Motor	M9887	• LS2 (RH RR), Momentary	28021-0061
• Circuit Breakers		• LS3 (RH Front), Inter Lock.....	28021-0047
• CB1 - 15A.....	45037	• LS4 (LH Front), Inter Lock.....	28021-0047
• CB2 - 15A.....	45037	• Reset Button	35145
• CB3 - 15A.....	45037	• Mod Valve 1 (41647)	59450
• CB4 - 15A.....	45037	• Mod Valve 2 (41647)	59450
• CB5 - 3A.....	45036	• Photocell 1 Entrance	59112
• CB6 - 3A.....	45036	• Photocell 2 Exit	59112
• CB7 - 1A.....	45644	• Power Supply	M9608
• CB8 - 1A.....	45644	• Relay	59132
• Cooling Fan LH	M9616	• Signal Amplifier 1	31651
• Cooling Fan RH.....	M9616	• Signal Amplifier 2	31651
• Controller 1 DC	58679	• TB1 RR LT (3 Pole)	44390
• Controller 1 DC (split belt).....	58679	• TB2 RR LT (3 Pole)	44390
• Conveyor Motor.....	58678	• TB3 RR RT (3 Pole)	44390
• Conveyor Motor (split Belt).....	58678	• TB4 RR LT (8 Pole)	31047
• Dual Burner	54719	• TB5 Comp Brkt (4 Pole)	M0593
• Converter Module - Digital A041, Right.....	58669	• TB6 Comp Brkt (4 Pole)	M0593
• Control Module - Digital C14RS-A, Left	60088	• TC1 - 6" High Limit (33984).....	33812-1
• Thermocouple Module - Digital TC4, Middle	58668	• TC2 - 12", Oven Temp.....	33812-6
• Gas Valve	54724	• TC3 - 12", Oven Temp.....	33812-6
• Green Light (Reset Button)	35145	• TC4 - 2.5", Control Compartment.....	33812-8
• GT30 Display	60128	• XFMR1 - 240V/24V 65 VA.....	32108
• High Limit	33983	• XFMR2 - 240V/24V 65 VA.....	32108

Wiring Diagram on Page 26

VIEW OF INSTALLATION KIT (PART NUMBER 59057)

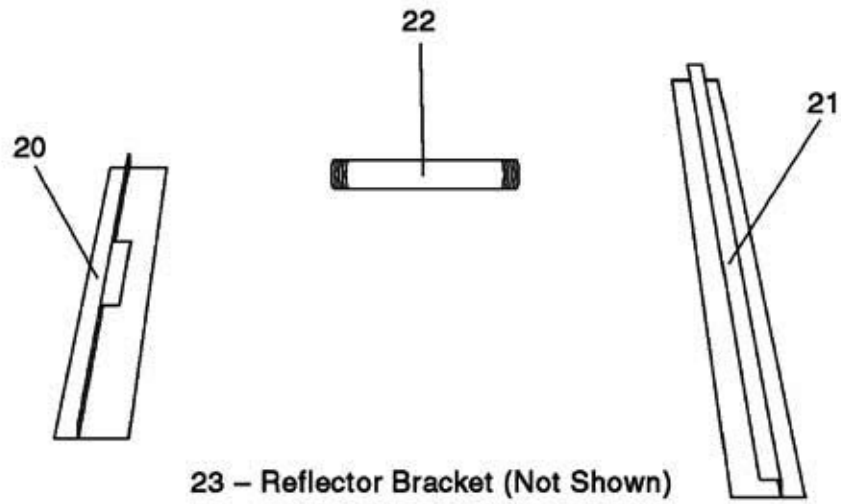

VIEW OF BASE PAD KIT

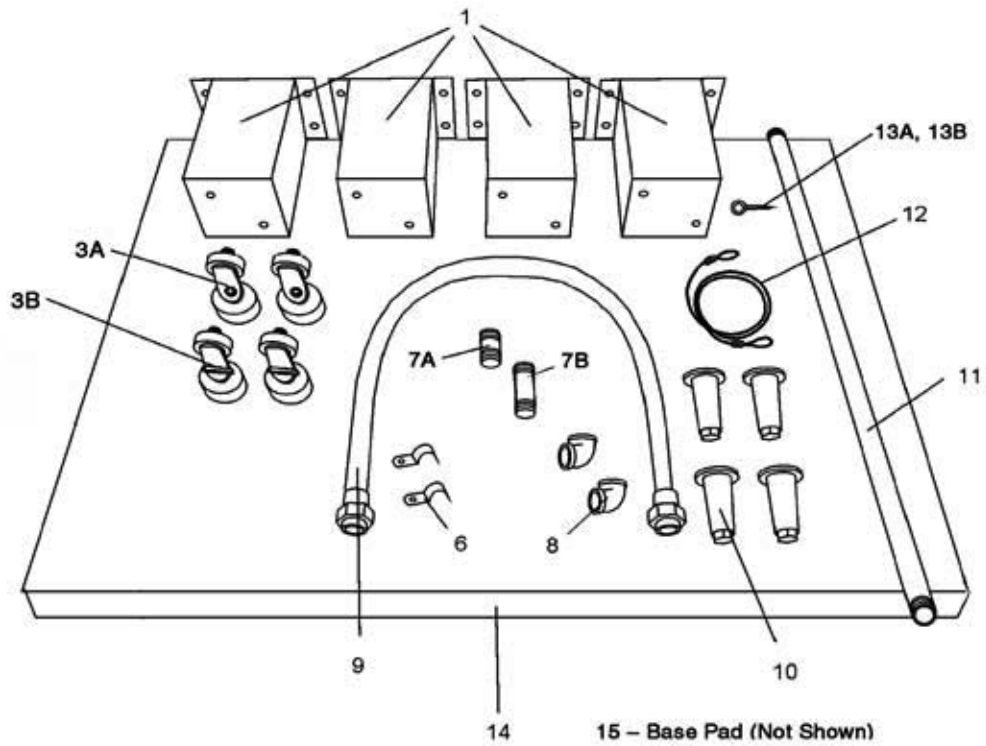

Parts for INSTALLATION KIT (Part Number 59057)

ITEM	QTY.-SGL. BELT	P/N	DESCRIPTION
20	1	55028	CONVEYOR REAR STOP, 18"
21	1	55027	CONVEYOR END STOP, 29-1/4"
22A	1	33120-0053	GAS PIPE NIPPLE, 1-1/4" X 9-1/2"
22B	2	59910	GAS PIPE NIPPLE, 1-1/4" X 4"
23	1	59419	BRACKET, REFLECTOR, R.H.

ITEM	QTY. SGL OVEN 19"LEGS 49026-0009	QTY. SGL/DBL OVEN/W 15"LEGS 49026-0011	QTY. TRIPLE OVEN 49026-0012	P/N	DESCRIPTION
1A	4	—	—	37210-0060	LEG, 19" (483mm) (OPTIONAL)
1C	—	4	—	37210-0057	LEG, 15" (381mm)
1D	—	—	4	39684	LEG, 4" (102mm) (43158, set of 4)
3A	2	2	2	37115-0102	CASTER, SWIVEL WITH 3/4" STUD
3B	2	2	2	58930	CASTER, SWIVEL WITH BRAKE
6	2	2	2	27271-0004	PIPE CLAMP, 1-1/2"
7A	2	2	2	33120-0055	NIPPLE, 1-1/4" DIA. X 3" L, NPT
7B	1	1	1	33120-0054	PIPE, 1-1/4" DIA. X 6" L
7C	2	2	2	59910	GAS PIPE 1-1/4" X 4"
8	2	2	2	23122-0007	ELBOW, 90°, 1-1/4" DIA.
9	1	1	1	22361-0003	GAS HOSE, 1-1/4" DIA. x 72" L
10	4	4	4	22450-0028	LEG, 6" (152mm) ADJUSTABLE WITH 3/4" STUD
11	1	1	1	33120-0056	GAS PIPE, 1-1/4" DIA. x 54" L
12	1	1	1	22450-0253	RESTRAINT CABLE, 60" (1524mm)
13A	1	1	1	21392-0005	EYE BOLT, WALL
13B	1	1	1	37699	EYE BOLT, BASE PAD
14	2	2	2	35210-0656	TOP COVER (RIGHT OR LEFT)

NOT SHOWN:

15	1	1	1	37210-0055	BASE PAD
16	2	2	2	21292-0001	SCREW, TEKS HWH #2PT #10-16 x 3/4"
17	16	16	—	21216-0018	BOLT, HEX CAP 1/2"-13 x 1-1/4"
18	16	16	—	21416-0003	FLAT WASHER, 1/2"
19	16	16	—	21426-0004	LOCK WASHER, 1/2"
20	8	8	8	59156	SCREW, TOP COVER, 1-1/2" LONG

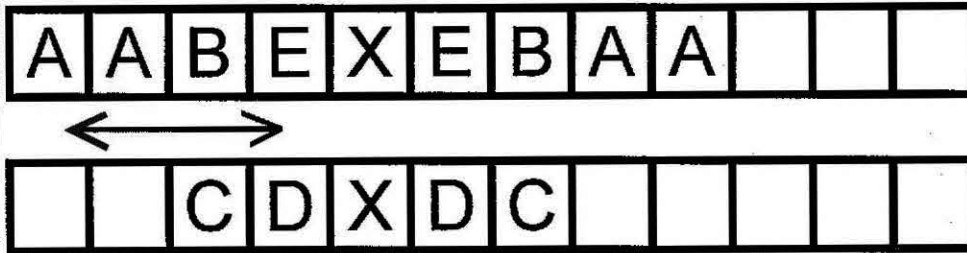

Notes

SYMMETRICAL FINGER CONFIG.
 AVG CONTROL T/CS: 4 USED
 ENT: TOP INNER & OUTER LOCATIONS: 12" PROBES
 EXIT: TOP INNER & OUTER LOCATIONS: 12" PROBES
 RPM= 2100RPM, INVERTERS SET @ 63HZ
 BOTH SIDES END PLUGS HAVE DIVERTERS
 PARTITION KIT RAISED P/N 59834

- A = 45084 WLDMT,OTR PLT W/EXT TAB S/L4
 35000-1366 PLATE,INNER PERF L6 ALUZ
 45083 WLDMT,RAISED MANF W/PERF BAF
- B = 39225 WLDMT,PLT OTR S/L6 W/EXT TAB
 35000-1366 PLATE,INNER PERF L6 ALUZ
 45083 WLDMT,RAISED MANF W/PERF BAF
- C = 37900-0051 PLATE,OUTER S/L6
 35000-1366 PLATE,INNER PERF L6 ALUZ
 36449 WLDMT,MANF W/PERF BAFFLE ALUZ
- D = 44476 WLDMT,OTR PLATE L18 W/14 ROWS
 35210-0520 PLATE,INNER PERF L18 ALUZ
 43034 WLDMT,MANF W/PERF BAF ALUZ L18
- E = 35210-0535 PLATE,BLANK PRTL 2.75 UPR

F =

G =

Description

CONFIG,FNGR PS670G STD

P/N 60188 Rev B



B	3/26/2007	RELEASE TO PRODUCTION ECN 007061	AJ
Rev	Date	Description	By

View of PANELS, END PLUGS and WINDOW

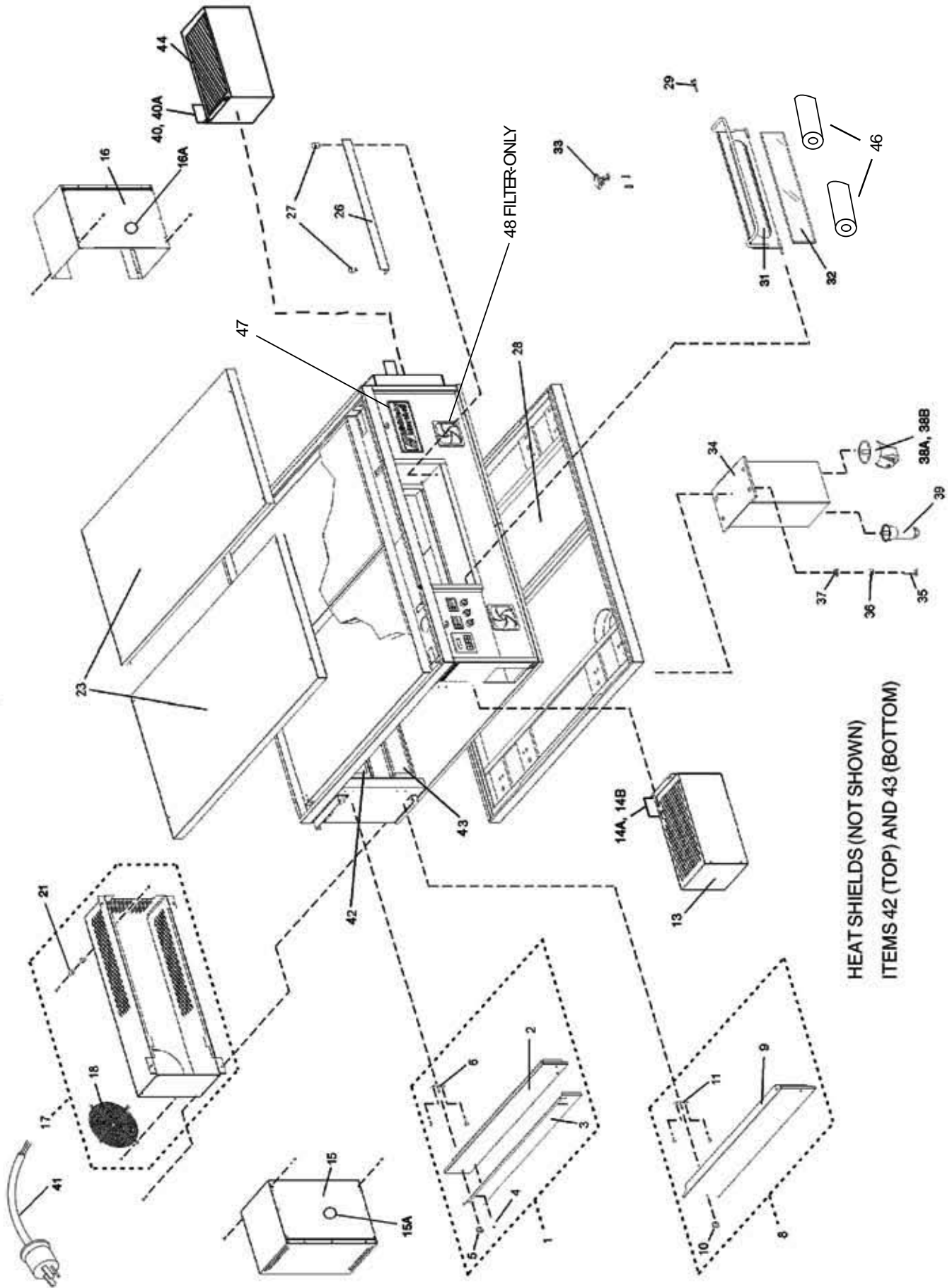

**HEAT SHIELDS (NOT SHOWN)
ITEMS 42 (TOP) AND 43 (BOTTOM)**

Parts for PANELS, END PLUGS and WINDOW

ITEM QTY.	P/N	DESCRIPTION
1	39539	ASSY, UPPER END PLUG (INC. ITEMS 2-6)
2	41778	WELDMNT, UPPER END PLUG
3	50834	EYEBROW
4	220295	SCREW, "AB" HEX WSHR HD #10 X 3/4"
5	36452	WING NUT, 1/4"-20 W/PLASTIC GRIP
6	41708	PLATE, END PLUG MOUNTING
8	39569	ASSY, LOWER END PLUG (INC. ITEMS 9-11)
9	41779	WELDMNT, LOWER END PLUG PS500
10	36452	WING NUT, 1/4"-20 W/PLASTIC GRIP
11	41708	PLATE, END PLUG MOUNTING
13	57501	ASSEMBLY, DRIVE MOTOR SHROUD
14A	59098	BRACKET FOR REFLECTOR
14B	59099	REFLECTOR
15	57286	ASSEMBLY, LEFT MOTOR SHROUD
15A	58758	GLASS, 2" x 2" x 0.25"
16	57293	ASSEMBLY, RIGHT MOTOR SHROUD
16A	58758	GLASS, 2" x 2" x 0.25"
17	54715	ASSEMBLY, REAR SHROUD (INC. ITEM 18 & 19)
18	31765	GRILL, COOLING FAN
21	48522	SPACER
23	35210-0656	TOP COVER
26	42488	WINDOW GUARD
27	30927	BUMPER, WINDOW

ITEM QTY.	P/N	DESCRIPTION
28	37210-0055	BASE PAD
29	34121-0003	SCREW, WINDOW PIVOT
31	45012	ASSEMBLY, WINDOW/LATCH (INC. ITEM 32 & 33)
32	41597	GLASS, WINDOW, PRE-CUT, 3-1/2" X 20"
33	45087	LATCH
34A	37210-0060	LEG, 19"
34B	37210-0057	LEG, 15"
34C	39684	LEG, 4"
35	21216-0018	BOLT, HEX CAP 1/2"-13 X 1-1/4" - SINGLE & DOUBLE OVENS
36	21426-0004	LOCKWASHER, 1/2" - SGL & DBL OVENS
37	21416-0003	FLAT WASHER, 1/2" - SGL & DBL OVENS
38A	37115-0102	CASTER, SWIVEL WITH 3/4" STUD - SINGLE, DOUBLE, & TRIPLE OVENS
38B	58930	CASTER, SWIVEL WITH BRAKE
39	22450-0028	LEG, 6" (152mm) ADJUSTABLE WITH 3/4" STUD - SINGLE, DOUBLE, & TRIPLE OVENS
40	59098	BRACKET, REFLECTOR, RIGHT HAND
40A	59099	REFLECTOR
41	49975	CORD & PLUG, L6-20P
42	59338	HEAT SHIELD, TOP.
43	59049	HEAT SHIELD, BOTTOM
44	59226	ASSEMBLY, SHROUD, RIGHT HAND
46	59562	COOL HANDLE INSULATOR
47	58764	MIDDLEBY LOGO
48	310-2468	FILTER ONLY
49	59834	Partition Kit
50	59456	Partition Raised
51	59464	Bottom Partition

View of GAS PIPING

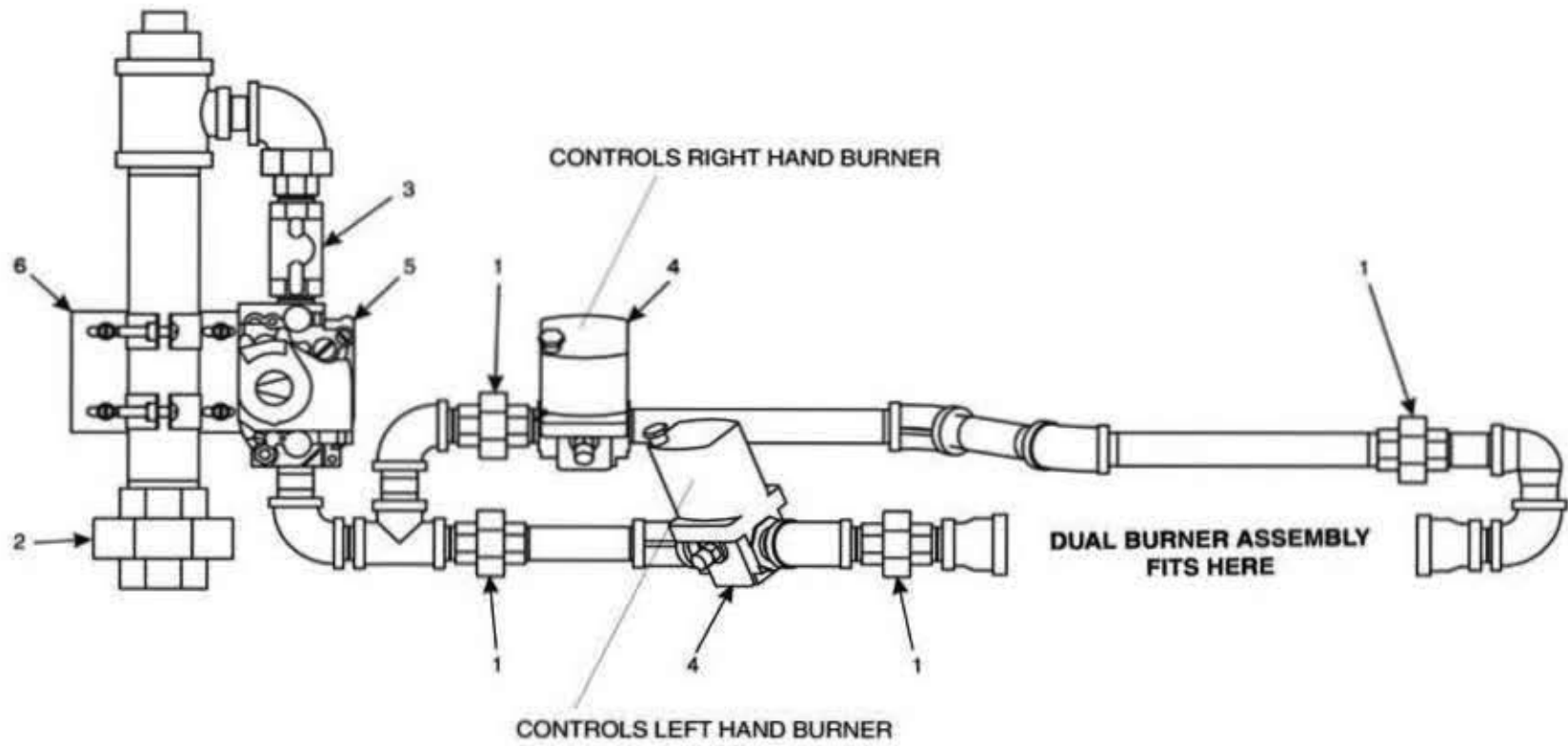

Parts for GAS PIPING

ITEM	QTY.	P/N	DESCRIPTION
1	4	23051-0003	UNION, 1/2"
2	1	23051-0012	UNION, 1-1/4"
3	1	23115-0009	MANUAL ON/OFF GAS VALVE, 1/2", BALL
4	2	59450	MODULATING GAS VALVE, 1/2" (41647)
5	1	54724	VALVE, COMBINATION, 1/2" -NATURAL GAS
5A	1	28092-0018	SPRING FOR LP CONVERSION
6	1	42410-0016	BRACKET/CLAMP

View of BURNER/BLOWER MOTOR ASSEMBLY

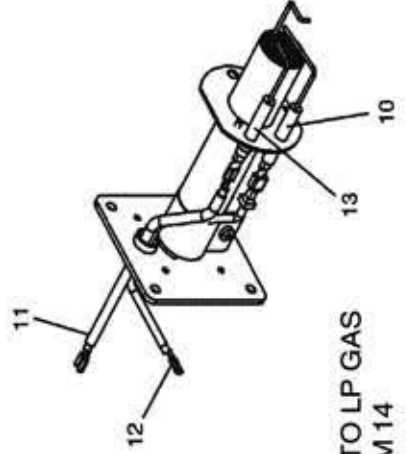
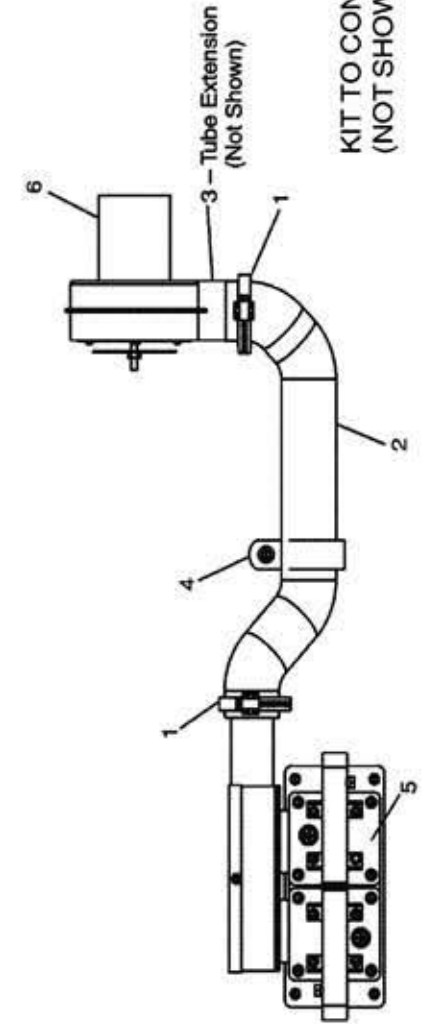
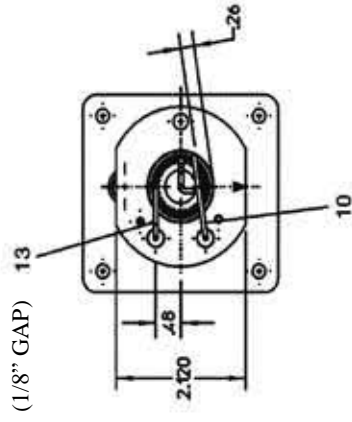
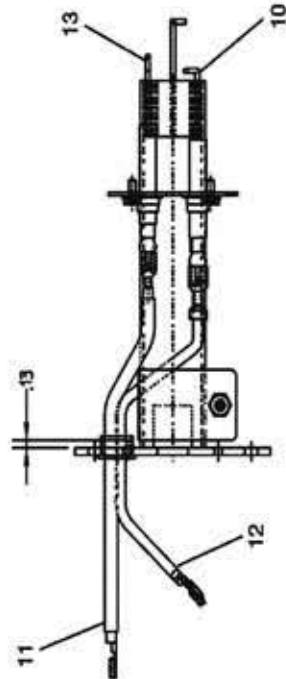
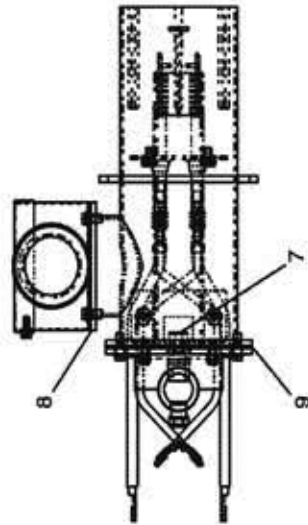
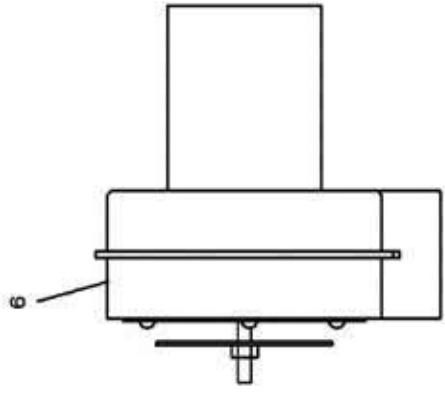
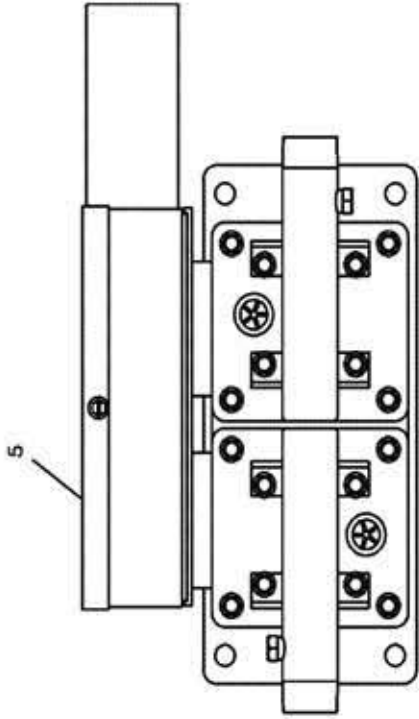
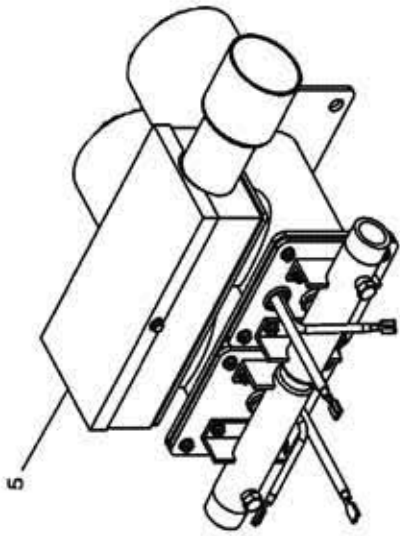

KIT TO CONVERT TO LP GAS
(NOT SHOWN) ITEM 14

Parts for BURNER/BLOWER MOTOR ASSEMBLY

ITEM	QTY.	P/N	DESCRIPTION
1	2	22450-0259	CLAMP, DUCT
2	1	22450-0255	DUCT
3	1	35210-0053	TUBE EXTENSION (Not Shown)
4	1	58754	CLAMP
5	1	54719	DUAL ASSEMBLY BURNER
(As of 5/1/07 - Targets are Positioned Inside Burner Tubes)			
6	1	M9887	BURNER/BLOWER MOTOR, 24V DC
7	2	Contact Factory	ORIFICE, NATURAL GAS, .173, #17
8	1	Contact Factory	GASKET, AIR INTAKE
9	1	Contact Factory	GASKET, DUAL VERTURE
10	2	58833	ELECTRODE, FLAME SENSOR
11	2	58836	WIRE, IGNITION, 27" LONG, 5mm
12	2	58835	WIRE, FLAME SENSOR, 36" LONG
13	2	58834	IGNITOR, ELECTRODE-1/8" GAP
14	1	Contact Factory	KIT TO CONVERT TO LP
14A	2	59074	ORIFICE, LP .118
14B	1	28092-0018	SPRINGFOR GASVALVE
15	1	Contact Factory	KIT TO CONVERT TO NAT GAS

View(s) of FRONT CONTROL AREA(S)

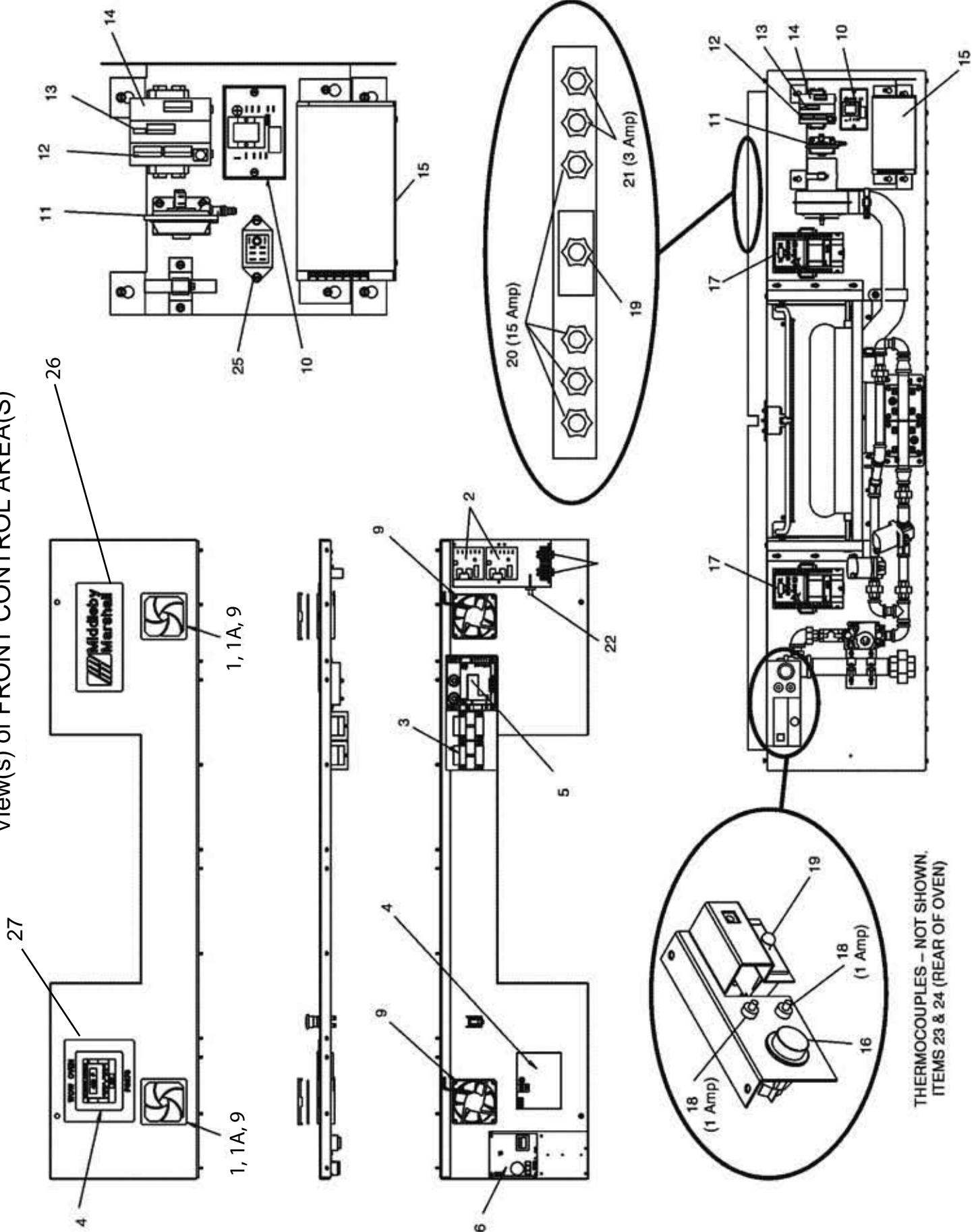

THERMOCOUPLES - NOT SHOWN.
ITEMS 23 & 24 (REAR OF OVEN)

Parts for FRONT CONTROL AREA(s)

ITEM	QTY.	P/N	DESCRIPTION
1	2	310-2458	FILTER/GUARD, FAN
1A	2	310-2468	FILTER ONLY
2	2	31651	AMPLIFIERBOARD
3	2	32108	TRANSFORMER, 240/24V, 65VA
4	1	60128	TOUCH SCREEN DISPLAY
5	1	54727	DUAL IGNITION MODULE
6	1 or 2	58679	CONTROLLER, CONVEYOR
8	2	M0593	TERMINAL BLOCK, 2-POLE
9	2	M9616	COOLING FAN, 24VDC
10	1	33983	HI-LIMIT CONTROL
11	1	57141	AIR SWITCH, FRONT, BURNER/BLOWER
12	1	60088	CONTROL, (LEFT-HAND), DIGITAL, C14RS -PROGRAMMED
13	1	58668	THERMOCOUPLE (MIDDLE), CONTROL, TC4
14	1	58669	CONVERTER, (RIGHT-HAND), A041
15	1	M9608	POWER SUPPLY, 24VDC
16	1	35145	RESET SWITCH W/GREEN LIGHT, HI-LIMIT
17	2	60126	INVERTOR -PROGRAMMED
18	2	45644	CIRCUIT BREAKER, 1 AMP
19	2	28021-0047	SWITCH, INTERLOCK
20	4	45037	CIRCUIT BREAKER, 15 AMP
21	2	45036	CIRCUIT BREAKER, 3 AMP
22	1	33812-8	THERMOCOUPLE, 2.5" x 60", CONTROL COMPARTMENT
23	4	33812-6	THERMOCOUPLE, 12"x120" REAR OF OVEN
24	1	33812-1	THERMOCOUPLE 6" (HIGH LIMIT) REAR OF OVEN (33984)
25	1	59132	RELAY, DPDT, 24VDC COIL
26	1	58764	MIDDLEBY LOGO
27	1	59085	LABLE - MIDDLEBY MARSHALL WOW OVEN

View(s) of REAR COMPARTMENT AND BLOWER (CONVEYOR DRIVE END SHOWN)

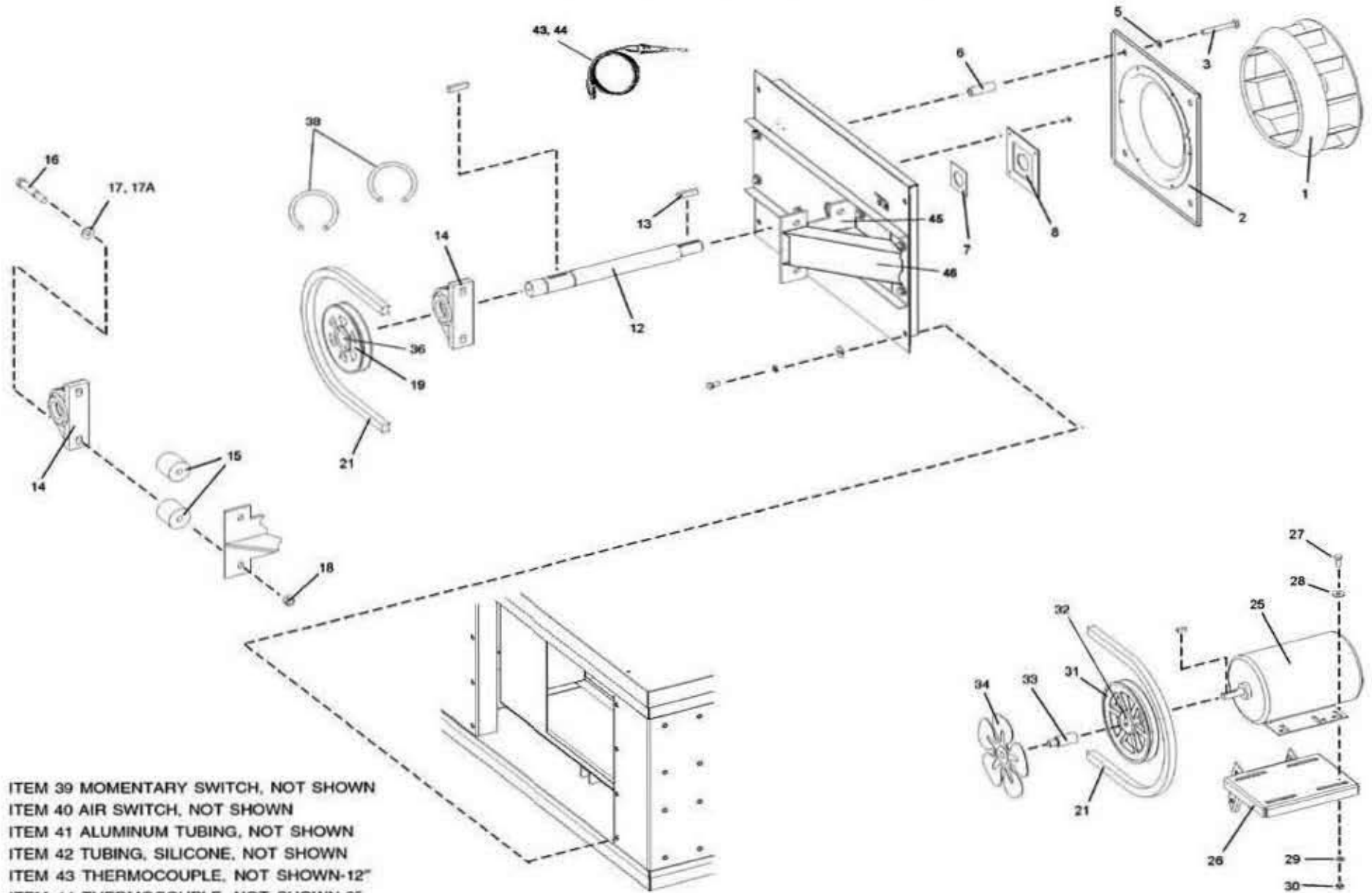

- ITEM 39 MOMENTARY SWITCH, NOT SHOWN
- ITEM 40 AIR SWITCH, NOT SHOWN
- ITEM 41 ALUMINUM TUBING, NOT SHOWN
- ITEM 42 TUBING, SILICONE, NOT SHOWN
- ITEM 43 THERMOCOUPLE, NOT SHOWN-12"
- ITEM 44 THERMOCOUPLE, NOT SHOWN-6"
- ITEM 47 PHOTO CELL
- ITEM 48 MOUNTING BRACKET, PHOTO CELL

NOTE: IDENTIFY THE DEFECTIVE INNER FROM THE DEFECTIVE OUTER BEARING ITEM 14 PER ENGINEERING'S REQUEST (THESE PARTS ARE TO BE RETURNED FOR OUR INSPECTION)

Parts for EACH REAR COMPARTMENT AND BLOWER

ITEM QTY.	P/N	DESCRIPTION
1A 1	22521-0005	BLOWER WHEEL, IDLER END
1B 1	22521-0006	BLOWER WHEEL, CONVEYOR DRIVE END
2 1	37210-0124	PLATE, INLET RING
3 4	21211-0001	SCREW, CAP HEX HD 3/8"-16 x 3"
5 10	21422-0001	LOCKWASHER, SPLIT 3/8"
6 4	35210-0576	SPACER
7 1	35210-0541	SHAFT SEAL, PTFE
8 1	37210-0101	PLATE, SHAFT SEAL INNER
12 1	57323	SHAFT BLOWER
13 1	35210-0286	KEY, BLOWER WHEEL
14 2	57321	BEARING
15 4	57320	SPACER, BEARING
16 4	2000535	SCREW, CAP HEX HD
17 4	A6235	FLATWASHER, 7/17"
17A 4	21422-0016	LOCKWASHER
18 4	21121-0013	HEX NUT, 1/2"-13
19 1	57295	PULLEY, 5"
21 1	58777	BELT
25 1	57288	MOTOR, BLOWER 2HP
26 1	59133	BRACKET, MOTOR MOUNTING
27 4	6673	SCREW, CAP HEX HD 5/16"-18 x 1"

ITEM QTY.	P/N	DESCRIPTION
28 4	A3682	LOCKWASHER, SPLIT 5/16"
31 1	57296	PULLEY, 5.6"
32 1	57297	INSERT, 5/8"
33 1	43024	EXTENDER, FAN
34A 1	27399-0008	FAN BLADE, CW, 8", CONVEYOR DRIVE END
34B 1	27399-0009	FAN BLADE, CCW, 8", IDLER END
35 1	57316	BRACKET, MOTOR SUPPORT
36 1	57298	INSERT, 1-7/16"
37 1	Contact Factory	KEY, 5/8 x 1
38 2	57325	RING
39 1	28021-0061	SWITCH, MOMENTARY
40 1	50610	AIR SWITCH
41 AP	15125-0002	ALUMINUM TUBING
42 AP	22450-0297	TUBING, SILICONE
43 4	33812-6	THERMOCOUPLE, 12" x 120", REAR OF OVEN
44 1	33812-1	THERMOCOUPLE 6" (HIGH LIMIT) (33984)
45 1	41575	MOUNTING BRACKET
46 1	44550	SUPPORT BRACKET
47 1	59112	PHOTO CELL, 24V DC
48 1	59108	MOUNTING BRACKET, PHOTO CELL

View of Single-Belt Conveyor

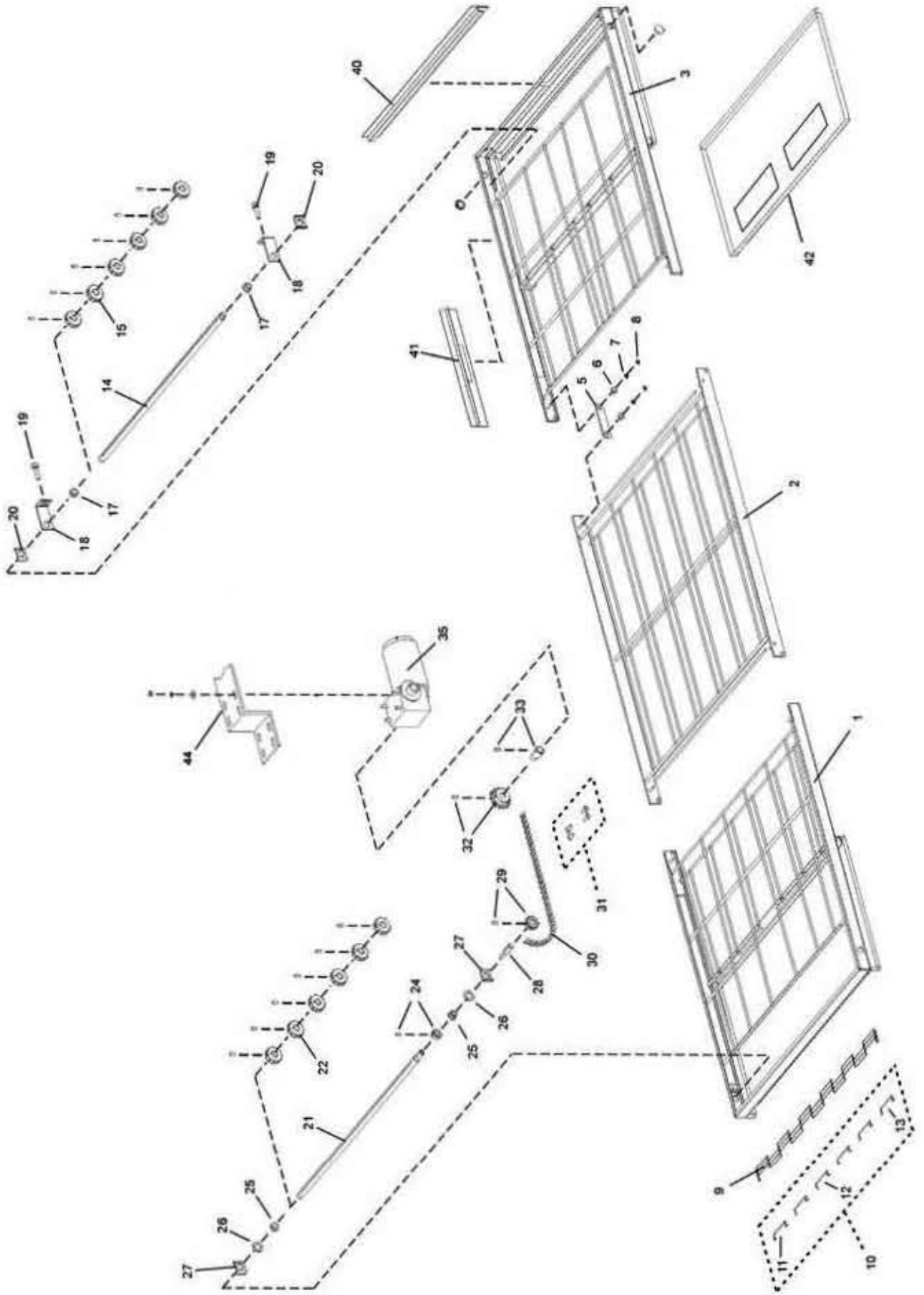

Parts for Single-Belt Conveyor

ITEM	QTY	PART NO.	DESCRIPTION
1	1	37210-0117	WELDMENT, CONVEYOR DRIVE FRAME
2	1	37210-0046	WELDMENT, CONVEYOR CENTER FRAME
3	1	37210-0116	WELDMENT, CONVEYOR IDLER FRAME
5	4	35210-0429	PIVOT PLATE
6	8	35210-0491	BUSHING, CONVEYOR ADJUSTMENT
7	8	F716A8805	WASHER, EXTERNAL TOOTH 1/4"
8	8	21176-0001	LOCKNUT, HEX 1/4"-20
9A	1	22450-0265	CONVEYOR BELT, COMPLETE, 32"W x 206"L
9B	--	33900-0032	CONVEYOR BELT, 32"W x 12"L (0.81 x 0.30m)
10	1	51380	MASTERLINKS KIT, 32" (0.81m) BELT (INC. ITEMS 11-13)
11	1	--	MASTERLINK, LEFT
12	4	--	MASTERLINK, CENTER
13	1	--	MASTERLINK, RIGHT
14	1	35000-1011	SHAFT, IDLER
15	6	22229-0003	SPROCKET, CONVEYOR BELT
17	2	22034-0003	BUSHING, BRONZE 3/4" O.D. x 5/8" I.D.
18	2	37000-0413	BRACKET, IDLER SHAFT ADJUSTMENT
19	2	35000-1008	SCREW, CONVEYOR TENSION ADJUSTMENT
20	2	54947	BRACKET, SHAFT SUPPORT
21	1	35000-1012	SHAFT, DRIVE

ITEM	QTY	PART NO.	DESCRIPTION
22	6	22229-0003	SPROCKET, CONVEYOR BELT
24	1	22011-0013	COLLAR, SHAFT, WITH SET SCREW
25	2	22034-0003	BUSHING, BRONZE 3/4" O.D. x 5/8" I.D.
26	2	35000-1080	SPACER, NYLON 1-1/4" O.D. x 3/4" I.D.
27	2	54947	BRACKET, SHAFT SUPPORT
28	1	35000-1013	ADAPTER, DRIVE SHAFT
29	1	22152-0017	SPROCKET, DRIVE SHAFT, 5/8" BORE, 9T, WITH SET SCREW
30	1	42400-0164	ASSEMBLY, ROLLER CHAIN (62 LINKS) WITH MASTERLINK
31	1	22273-0001	MASTERLINK, ROLLER CHAIN
32	1	22152-0018	SPROCKET, DRIVE MOTOR, 5/8" BORE, 15T, WITH SET SCREW
33	1	35210-0640	ADAPTER, DRIVE MOTOR WITH SET SCREW
35	1	58678	DRIVE MOTOR, BRUSHLESS, 1400:1 130VDC
40	1	55027	END STOP, CONVEYOR, 29-1/4" LONG
41	1	55028	REAR STOP, CONVEYOR, 18" LONG
42	2	30004	CRUMB PAN
43	1	M10098	HARNESS, WIRE
44	1	45035	MOUNTING BRACKET, DRIVE MOTOR

View of "SPLIT" Belt Conveyor

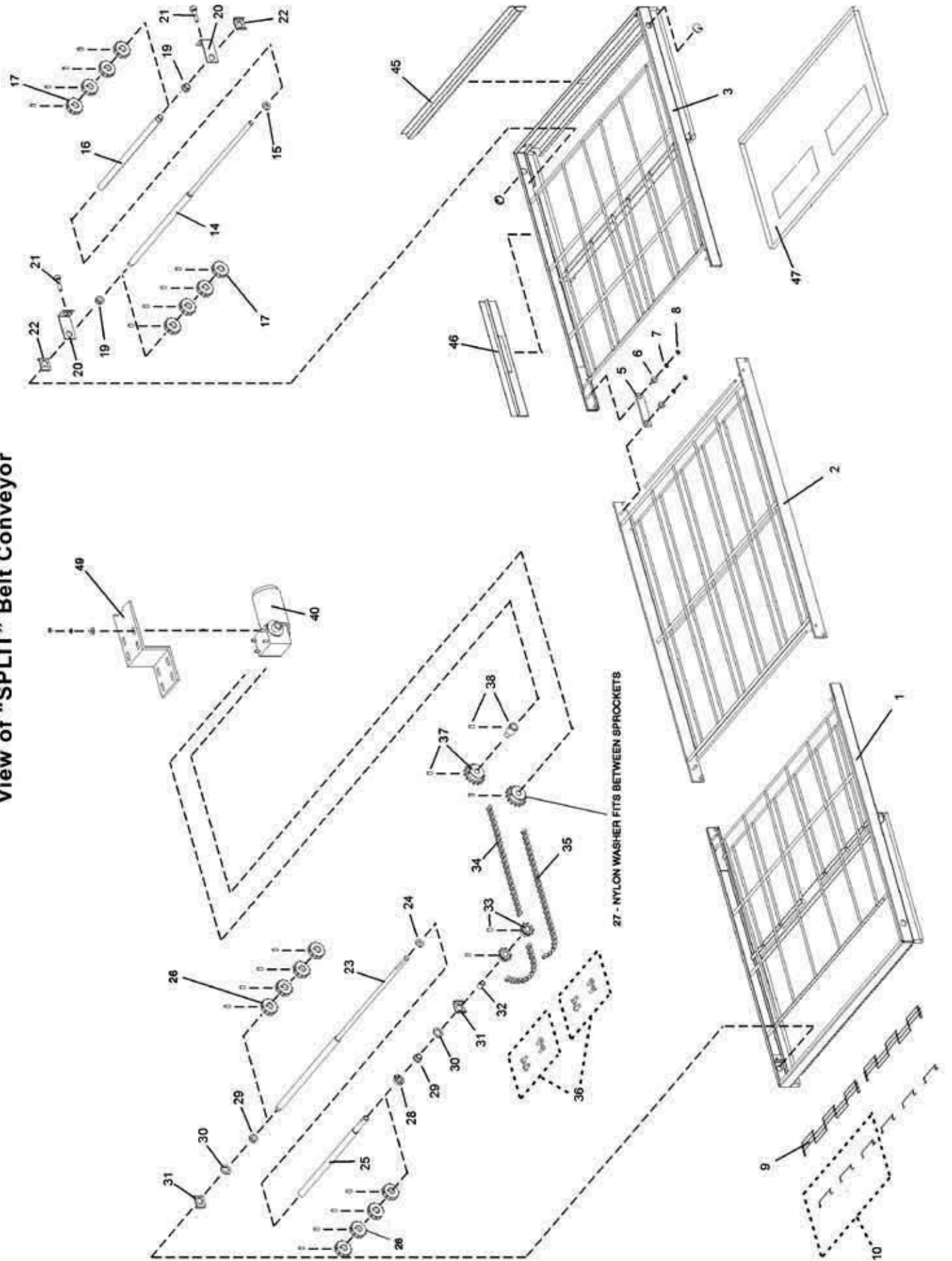

Parts for "SPLIT" Belt Conveyor

ITEM	QTY	PART NO.	DESCRIPTION	ITEM	QTY	PART NO.	DESCRIPTION
1	1	37210-0117	WELDMENT, CONVEYOR DRIVE FRAME	26	8	22229-0003	SPROCKET, CONVEYOR BELT
2	1	37210-0046	WELDMENT, CONVEYOR CENTER FRAME	27	1	35000-1531	SPACER, NYLON, FITS BETWEEN SPROCKET
3	1	37210-0116	WELDMENT, CONVEYOR IDLER FRAME	28	1	22011-0014	COLLAR, SPLIT LOCKING
5	4	35210-0429	PIVOT PLATE	29	2	22034-0003	BUSHING, BRONZE 3/4" O.D. x 5/8" I.D.
6	8	35210-0491	BUSHING, CONVEYOR ADJUSTMENT	30	2	35000-1080	SPACER, NYLON 1-1/4" O.D. x 3/4" I.D.
7	8	F716A8805	WASHER, EXTERNAL TOOTH 1/4"	31	2	54947	BRACKET, SHAFT SUPPORT
8	8	21176-0001	LOCKNUT, HEX 1/4"-20	32	1	35900-0023	BUSHING, SPLIT BELT DRIVE SPROCKET
9A	2	22450-0271	CONVEYOR BELT, COMPLETE, 15"W x 206"L (0.38 x 5.23m)	33	2	22152-0017	SPROCKET, DRIVE SHAFT, 5/8" BORE, 9T, WITH SET SCREW
9B	--	33900-0037	CONVEYOR BELT, 15"W x 12"L (0.38 x 0.30m)	34	1	42400-0164	ASSEMBLY, ROLLER CHAIN COMPLETE (62 LINKS)
10	2	51382	MASTERLINKS KIT, 15" (0.81m) BELT (INC. ITEMS 11-13)	35	1	42410-0128	ASSEMBLY, ROLLER CHAIN COMPLETE (48 LINKS)
14	1	42400-0354	SHAFT, IDLER, REAR, 32-3/4"	36	2	22273-0001	MASTERLINK, ROLLER CHAIN
15	1	21415-0001	FLAT WASHER, BRONZE, 1" O.D. X 1/2" I.D.	37	2	22152-0018	SPROCKET, DRIVE MOTOR, 5/8" BORE, 15T, WITH SET SCREW
16	1	35000-1535	SHAFT, IDLER, FRONT, 16-3/8"	38	1	35210-0640	ADAPTER, DRIVE MOTOR WITH SET SCREW
17	8	22229-0003	SPROCKET, CONVEYOR BELT	40	2	58678	DRIVE MOTOR, BRUSHLESS, 1/8 HP, 1400:1
19	2	22034-0003	BUSHING, BRONZE 3/4" O.D. x 5/8" I.D.	45	1	55027	END STOP, CONVEYOR, 29-1/4"
20	2	37000-0413	BRACKET, IDLER SHAFT ADJUSTMENT	46	1	55028	REAR STOP, CONVEYOR, 18"
21	2	35000-1008	SCREW, CONVEYOR TENSION ADJUSTMENT	47	2	30004	CRUMB PAN
22	2	54947	BRACKET, SHAFT SUPPORT	48	2	M10098	HARNESS, WIRE
23	1	42400-0355	SHAFT, DRIVE, REAR, 35-1/3"	49	1	45035	MOUNTING BRACKET, DRIVE MOTOR
24	1	21415-0001	FLAT WASHER, BRONZE, 1" O.D. X 1/2" I.D.				
25	1	35000-1536	SHAFT, DRIVE, FRONT, 17-3/4"				

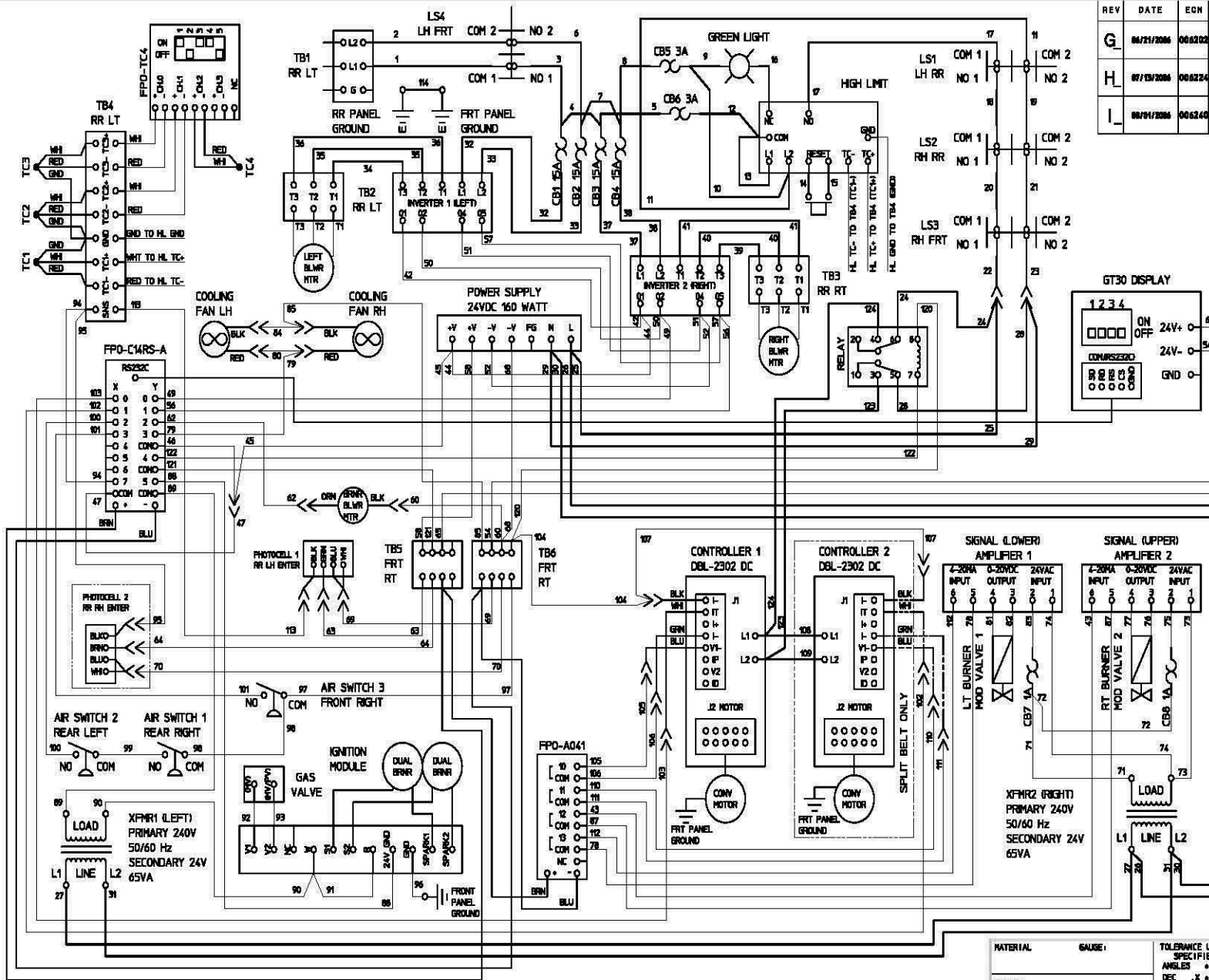

REV	DATE	ECN	REVISION DESCRIPTION	BY	CHK	DATE
G	06/21/2006	006202	REVERSED COLORS ON TC1 & CONNECTED SIGNAL AMPLIFIER INPUT & OUTPUT	MM	MS	06/21/2006
H	07/13/2006	006224	REVERSED POSITIONS (L & R) ON POWER SUPPLY	PC	MS	07/13/2006
I	08/01/2006	006240	CHG'D CONNECTOR POSITION NUMBERS	AR	MS	08/01/2006

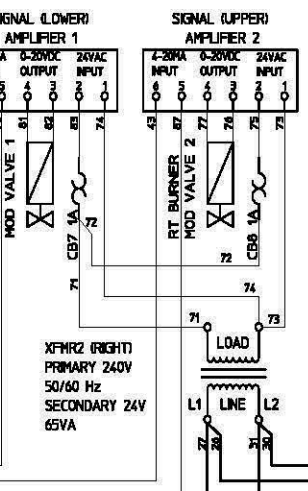
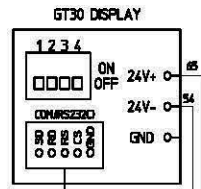

WD LABEL P/N 58813

MATERIAL	GAUGE:	TOLERANCE UNLESS SPECIFIED	THIS DRAWING IS CONFIDENTIAL AND PROPERTY OF THE MIDDLEBY CORPORATION 1400 Toumester Drive Egln, Illinois 60120 847-741-3300
FINISH		ANGLES ± 1.0° DEC .X ± .030 13 .XX ± .015 .XXX ± .005	
DRAWN	CHECKED	APPROVED	
AB	08/01/2006	MS	08/01/2006

WD, G208-240/50/60/1 PS870/770
 ALL DIMENSIONS ARE IN INCHES. DO NOT SCALE DRAWING.
 PART NO: 54745
 SHIT: 1 OF 1
 REV: I

