

PS770 Series  
Gas  
Domestic  
ENGLISH

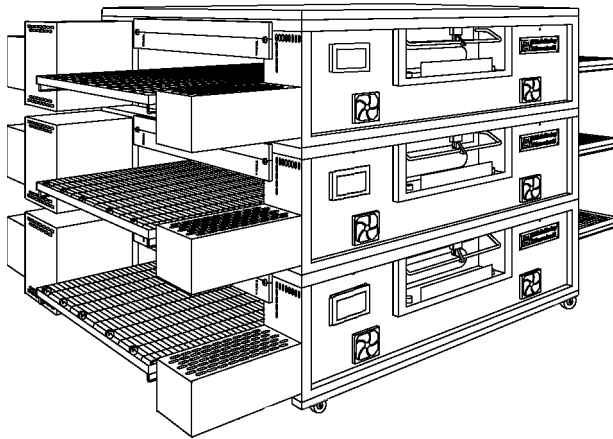

P/N 59026  
July 1, 2012 Rev. D



# PS770 Series Gas Ovens

## **Model:**

- PS770G Gas

## **Combinations:**

- Single Oven
- Double Oven (Two-Stack)
- Triple Oven (Three-Stack)

# ***OWNER'S OPERATING AND INSTALLATION MANUAL***

***for domestic and standard export ovens***

©2012 Middleby Marshall Inc.



is a registered trademark of Middleby Marshall, Inc. All rights reserved.

Middleby Cooking Systems Group • 1400 Toastmaster Drive • Elgin, IL 60120 • (847)741-3300 • FAX (847)741-4406





**NOTICE:**

This **Owner's Operating and Installation Manual** should be given to the user. The operator of the oven should be familiar with the functions and operation of the oven.

This manual must be kept in a prominent, easily reachable location near the oven.

Gas ovens are designed for use with EITHER natural gas OR liquid propane gas, as specified on the serial plate. Where permitted by local and national codes, the oven can be converted from natural gas to propane operation, or from propane to natural gas operation. This conversion requires the installation of the appropriate Middleby Marshall Gas Conversion Kit by an Authorized Service Agent.

It is suggested to obtain a service contract with a Middleby Marshall Authorized Service Agent.

**WARNING**

**POST, IN A PROMINENT LOCATION, THE EMERGENCY TELEPHONE NUMBER OF YOUR LOCAL GAS SUPPLIER AND INSTRUCTIONS TO BE FOLLOWED IN THE EVENT YOU SMELL GAS.**

Instructions to be followed in the event the user smells gas shall be obtained by consulting the local gas supplier. If the smell of gas is detected, immediately call the emergency phone number of your local Gas Company. They will have personnel and provisions available to correct the problem.

**FOR YOUR SAFETY**

**Do not store or use gasoline or other flammable vapors or liquids in the vicinity of this or any other appliance.**

**WARNING:**

**Improper installation, adjustment, alteration, service or maintenance can cause property damage, injury or death. Read the installation, operating and maintenance instructions thoroughly before installing or servicing this equipment.**

**IMPORTANT**

**An electrical wiring diagram for the oven is located inside the machinery compartment.**

**IMPORTANT**

**It is the customer's responsibility to report any concealed or non-concealed damage to the freight company. Retain all shipping materials until it is certain that the equipment has not suffered concealed shipping damage.**

**NOTICE:** CONTACT YOUR MIDDLEBY MARSHALL AUTHORIZED SERVICE AGENT TO PERFORM MAINTENANCE AND REPAIRS. AN AUTHORIZED SERVICE AGENCY DIRECTORY IS SUPPLIED WITH YOUR OVEN.

**NOTICE:** Using any parts other than genuine Middleby Marshall factory manufactured parts relieves the manufacturer of all warranty and liability.

**NOTICE:** Middleby Marshall (Manufacturer) reserves the right to change specifications at any time.

**NOTICE:** The equipment warranty is not valid unless the oven is installed, started and demonstrated under the supervision of a factory certified installer.

**Retain This Manual For Future Reference**

Middleby Cooking Systems Group • 1400 Toastmaster Drive • Elgin, IL 60120 • USA • (847)741-3300 • FAX (847)741-4406

**MIDDLEBY MARSHALL**  
**PAPA JOHN'S No Quibble Limited**  
**Warranty**

Middleby Marshall will repair the equipment  
24 hours a day, 365 days a year

*(U.S.A. Only)* **PS770 WOW Oven**

MIDDLEBY MARSHALL, HEREINAFTER REFERRED TO AS "THE SELLER", WARRANTS EQUIPMENT MANUFACTURED BY THEM TO BE FREE FROM DEFECTS IN MATERIAL AND WORKMANSHIP FOR WHICH IT IS RESPONSIBLE. THE SELLER'S OBLIGATION UNDER THIS WARRANTY SHALL BE LIMITED TO REPLACING OR REPAIRING, AT SELLER'S OPTION, WITHOUT CHARGE, ANY PART FOUND TO BE DEFECTIVE AND ANY LABOR AND MATERIAL EXPENSE INCURRED BY SELLER IN REPAIRING OR REPLACING SUCH PART. SUCH WARRANTY SHALL BE LIMITED TO THE ORIGINAL PURCHASER ONLY AND SHALL BE EFFECTIVE FOR A PERIOD OF THREE YEARS FROM DATE OF ORIGINAL INSTALLATION OR 42 MONTHS FROM DATE OF PURCHASE, WHICHEVER IS EARLIER, PROVIDED THAT TERMS OF PAYMENT HAVE BEEN FULLY MET.

This warranty is valid only if the equipment is installed, started, and demonstrated under the supervision of a factory-authorized installer.

Normal maintenance functions, including lubrication, cleaning, or customer abuse, are not covered by this **no quibble warranty**.

Seller shall be responsible only for repairs or replacements of defective parts performed by seller's authorized service personnel. Authorized service agencies are located in principal cities throughout the contiguous United States, Alaska, and Hawaii. This warranty is valid in the 50 United States and is void elsewhere unless the product is purchased through Middleby International with warranty included.

The foregoing warranty is exclusive and in lieu of all other warranties, expressed or implied. There are no implied warranties of merchantability or of fitness for a particular purpose.

The foregoing shall be seller's sole and exclusive obligation and buyer's sole and exclusive remedy for any action, including breach of contract or negligence. In no event shall seller be liable for a sum in excess of the purchase price of the item. Seller shall not be liable for any prospective or lost profits of buyer.

*This warranty is effective on Middleby Marshall equipment sold on or after April 1, 2006.*

**MIDDLEBY MARSHALL INC.**  
**OVEN LIMITED WARRANTY**  
**(Non U.S.A.)**

The Seller warrants equipment manufactured by it to be free from defects in material and workmanship for which it is responsible. The Seller's obligation under this warranty shall be limited to replacing or repairing, at Seller's option, without charge, F.O.B. Seller's factory, any part found to be defective and any labor and material expense incurred by Seller in repairing or replacing such part. Such warranty is limited to a period of one year from date of original installation or 15 months from date of shipment from Seller's factory, whichever is earlier, provided that terms of payment have been fully met. All labor shall be performed during regular working hours. Overtime premium will be charged to the Buyer.

**This warranty is not valid unless equipment is installed, started, and demonstrated under the supervision of a factory-authorized installer.**

Normal maintenance functions, including lubrication, adjustment of airflow, thermostats, door mechanisms, microswitches, burners and pilot burners, and replacement of light bulbs, fuses and indicating lights, are not covered by warranty.

Any repairs or replacements of defective parts shall be performed by Seller's authorized service personnel. Seller shall not be responsible for any costs incurred if the work is performed by other than Seller's authorized service personnel.

When returning any part under warranty, the part must be intact and complete, without evidence of misuse or abuse, freight prepaid.

Seller shall not be liable for consequential damages of any kind which occur during the course of installation of equipment, or which result from the use or misuse by Buyer, its employees or others of the equipment supplied hereunder, and Buyer's sole and exclusive remedy against Seller for any breach of the foregoing warranty or otherwise shall be for the repair or replacement of the equipment or parts thereof affected by such breach.

The foregoing warranty shall be valid and binding upon Seller if and only if Buyer loads, operates and maintains the equipment supplied hereunder in accordance with the instruction manual provided to Buyer. Seller does not guarantee the process of manufacture by Buyer or the quality of product to be produced by the equipment supplied hereunder and Seller shall not be liable for any prospective or lost profits of Buyer.

THE FOREGOING WARRANTY IS EXCLUSIVE AND IN LIEU OF ALL OTHER EXPRESS AND IMPLIED WARRANTIES WHATSOEVER. SPECIFICALLY THERE ARE NO IMPLIED WARRANTIES OF MERCHANTABILITY OR OF FITNESS FOR A PARTICULAR PURPOSE.

The foregoing shall be Seller's sole and exclusive obligation and Buyer's sole and exclusive remedy for any action, whether in breach of contract or negligence. In no event shall seller be liable for a sum in excess of the purchase price of the item.

# Table of Contents

	Page		Page
<b>SECTION 1</b>		<b>IV. ASSEMBLY</b> .....	<b>10</b>
DESCRIPTION .....	6	A. Base Pad, Legs, Casters, and Stacking .....	10
I. OVEN USES .....	6	B. Restraint Cable Installation .....	10
II. OVEN COMPONENTS .....	6	C. Conveyor Installation .....	10
A. Conveyor Motor Drive .....	6	D. Standoff Installation .....	11
B. Crumb Pans .....	6	V. FINAL ASSEMBLY .....	12
C. Conveyor End Stop and Rear Stop .....	6	VI. ELECTRICAL SUPPLY .....	12
D. Conveyor End Stop and Rear Stop .....	6	Connection .....	13
E. Conveyor .....	6	VII. GAS SUPPLY .....	13
F. End Plugs .....	6	A. Gas Utility Rough-In Recommendations .....	13
G. Eyebrows .....	6	B. Connection .....	14
H. Window .....	6	C. Gas Conversion .....	14
I. Machinery Compartment Access Panel .....	6	D. Propane Conversion .....	14
J. Serial Plate .....	6	<b>SECTION 3</b>	
K. Control Panel .....	6	OPERATION .....	15
L. Gas Burner .....	6	I. LOCATION AND DESCRIPTION OF CONTROLS .....	15
M. Blowers .....	6	II. NORMAL OPERATION, STEP-BY-STEP .....	16
N. Air Fingers .....	6	A. Daily Startup Procedure .....	16
III. OVEN SPECIFICATIONS .....	6	B. Daily Shutdown Procedure .....	16
A. Dimensions .....	6	III. ENERGY MODE .....	17
B. General Specifications .....	6	IV. SCREEN ALERTS .....	17
C. Electrical Specifications for PS770 Gas Ovens .....	7	<b>SECTION 4</b>	
D. Gas Orifice and Pressure Specifications for PS770 Gas Ovens .....	7	MAINTENANCE .....	18
<b>SECTION 2</b>		I. MAINTENANCE - DAILY .....	18
INSTALLATION .....	7	II. MAINTENANCE - MONTHLY .....	19
I. BASE PAD KIT .....	8	III. MAINTENANCE - EVERY 3 MONTHS .....	20
II. INSTALLATION KIT .....	9	IV. MAINTENANCE - EVERY 6 MONTHS .....	21
III. VENTILATION SYSTEM .....	9	V. KEY SPARE PARTS KIT .....	22
A. Requirements .....	9	<b>SECTION 5</b>	
B. Recommendations .....	9	ELECTRICAL WIRING DIAGRAM .....	23
C. Other Ventilation Concerns .....	9	I. WIRING DIAGRAM, 770 GAS OVEN, 208/240V, 50/60 Hz, 1 Ph .....	23

# SECTION 1 - DESCRIPTION

## I. OVEN USES

PS770 Series Ovens can be used to bake and/or cook a wide variety of food products, such as pizza, pizza-type products, cookies, sandwiches and others.

## II. OVEN COMPONENTS - see Figure 1-1.

- A. Conveyor Drive Motor:** Moves the conveyor.
- B. Crumb Pans:** Catch crumbs and other material that drop through the conveyor belt. One crumb pan is located at each end of the conveyor.
- C,D. Conveyor End Stop and Rear Stop:** Prevent food products from falling off the end or rear of the moving conveyor.
- E. Conveyor:** Moves the food product through the oven.
- F. End Plugs:** Allow access to the oven's interior.
- G. Eyebrows:** Can be adjusted to various heights to prevent heat loss into the environment.
- H. Window:** Allows the user to access food products inside the baking chamber.
- I. Machinery Compartment Access Panel:** Allows access to the oven's interior and control components. No user-servicable parts are located in the machinery compartment.
- J. Serial Plate:** Provides specifications for the oven that affect installation and operation. Refer to Section 2, Installation, for details.

- K. Control Panel:** Location of the operating controls for the oven. Refer to Section 3, Operation, for details.

*Not Shown:*

- L. Gas Burner (gas ovens)** Heat air, which is then projected to the air fingers by the blowers.
- M. Blowers:** Project hot air from the burner or heating elements to the air fingers.
- N. Air Fingers:** Project streams of hot air onto the food product.

Figure 1-1 - Oven Components

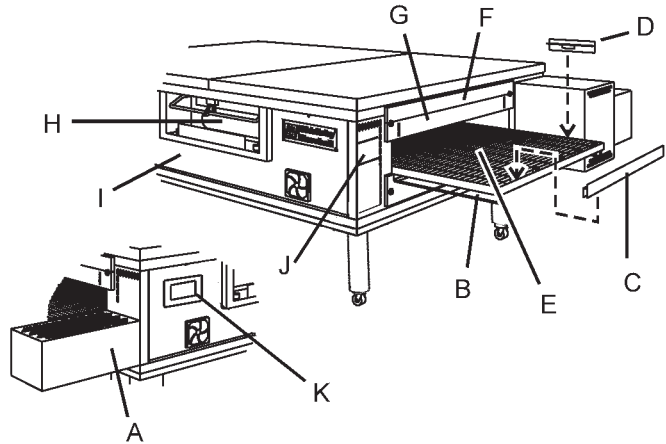

## III. OVEN SPECIFICATIONS

Table 1-1: Dimensions	Single Oven	Double Oven	Triple Oven
Overall Height	47" (1194mm)	61" (1549mm)	63-7/8" (1622mm)
Overall Depth	63-3/8" (1610mm)	63-3/8" (1610mm)	63-3/8" (1610mm)
Overall Length, PS770G	106" (2692mm)	106" (2692mm)	106" (2692mm)
Conveyor Width	32" (813mm) or 2x15" (381mm)	32" (813mm) or 2x15" (381mm)	32" (813mm) or 2x15" (381mm)
Recommended Minimum Clearances			
Rear of Oven (inc. rear shrouds) to Wall	6" (152mm)	6" (152mm)	6" (152mm)
Conveyor Extension to Wall (both ends)	0" (0 mm)	0" (0 mm)	0" (0 mm)

Table 1-2: General Specifications	PS770G
Weight	1400 lbs. (634kg)
Rated Heat Input	175,000 BTU (42,840 kcal, 50 kW/hr) OR 210,000 BTU (52,919 kcal, 61.5 kW/hr)
Maximum Operating Temperature	< ----- 550°F / 288°C ----- >
Air Blowers	Two blowers at 1400 ft. <sup>3</sup> /min. (39.6m <sup>3</sup> /min.) at 2050 RPM, 0.40" (1.0cm) Water Static Pressure
Average Air Jet Velocity	< ----- 2600 ft./min. (1320cm/sec.) average ----- >
Warmup Time	< ----- 15 min. ----- >

**Table 1-3: Electrical specifications for PS770G gas ovens**

Main Blower Voltage	Control Circuit Voltage	Phase	Freq	Current Draw	Poles	Wires
208-240V	24 VDC	1 Ph	50/60Hz	20 Amp	2 Pole	3 Wire (2 hot, 1 gd)

**Table 1-4: Gas orifice and pressure specifications for PS770G gas ovens**

Gas Type	Main Orifice I.D. PS770G	Supply (Inlet) Pressure	Orifice (Manifold) Pressure
Natural	0.173	8-12" W.C. (19.9-29.9mbar)	3.5" W.C. (8.7mbar)
Propane	.0.141	11-14" W.C. (27.4-34.9mbar)	3.5" W.C. (8.7mbar)

**IMPORTANT** - Additional electrical information is provided on the oven's serial plate, and on the wiring diagram inside the machinery compartment.

## SECTION 2 - INSTALLATION

**WARNING - After any conversions, readjustments, or service work on the oven:**

- Perform a gas leak test.
- Test for proper combustion and gas supply.
- Test for correct air supply, particularly to the burner blower.
- Check that the ventilation system is in operation.

**WARNING - Keep the appliance area free and clear of combustibles.**

**WARNING - The oven must be installed on an even (level) non-flammable flooring and any adjacent walls must be non-flammable. Recommended minimum clearances are specified in the *Description* section of this Manual.**

**WARNING - Do not obstruct the flow of combustion and ventilation air to and from your oven. There must be no obstructions around or underneath the oven. Constructional changes to the area where the oven is installed shall not affect the air supply to the oven.**

**CAUTION: To reduce the risk of fire, the appliance is to be mounted on floors of noncombustible construction with noncombustible flooring and surface finish and with no combustible material against the underside thereof, or on noncombustible slabs or arches having no combustible material against the underside thereof, such construction shall in all cases extend not less than 12 inches (304.8mm) beyond the equipment on all sides.**

**CAUTION - For additional installation information, contact your local Authorized Service Agent.**

**NOTE - There must be adequate clearance between the oven and combustible construction. Clearance must also be provided for servicing and for proper operation.**

**NOTE - An electrical wiring diagram for the oven is located inside the machinery compartment.**

**NOTE:** All aspects of the oven installation, including placement, utility connections, and ventilation requirements, must conform with any applicable local, national, or international codes. These codes supercede the requirements and guidelines provided in this manual.

**NOTE:** In the USA, the oven installation must conform with local codes. In the absence of local codes, gas oven installations must conform with the National Fuel Gas Code, ANSI Z223.1. Gas and electric ovens, when installed, must be electrically grounded in accordance with local codes, or in the absence of local codes, with the National Electrical Code (NEC), or ANSI/NFPA70.

**NOTE:** In Canada, the oven installation must conform with local codes. In the absence of local codes, gas oven installations must conform with the Natural Gas Installation Code, CAN/CGA-B149.1, or the Propane Gas Installation Code, CAN/CGA-B149.2, as applicable. Gas and electric ovens, when installed, must be electrically grounded in accordance with local codes, or in the absence of local codes, with the Canadian Electrical Code CSA C22.2.

**NOTE:** In Australia, the oven installation must conform with any requirements of the appropriate statutory authority. Gas oven installations must conform with AGA Code, AG601.

Fig. 2-1 - Base Pad Kit

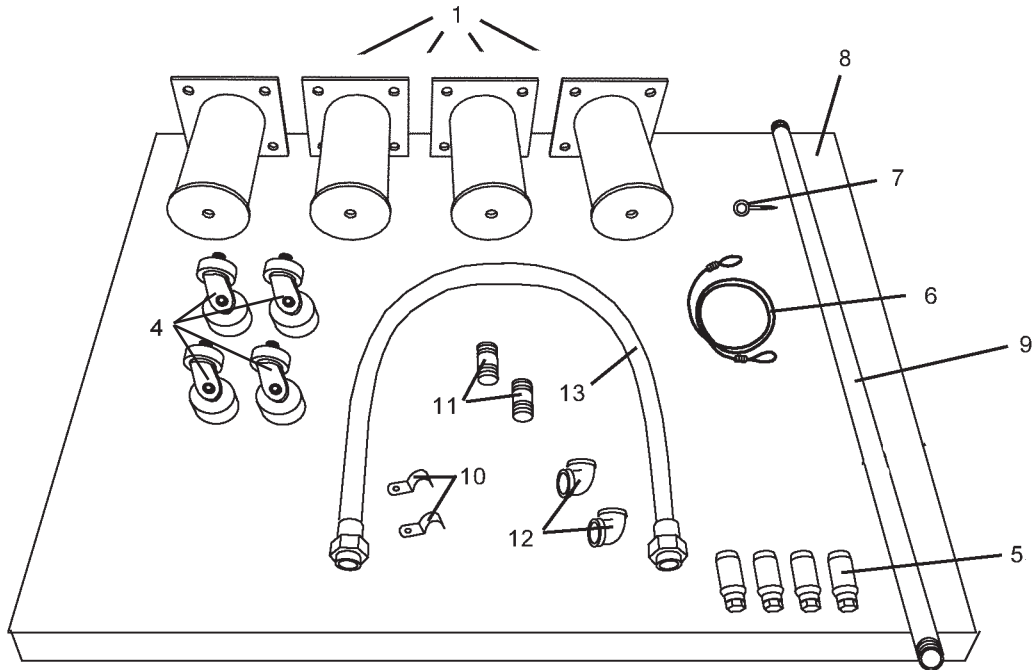

**I. BASE PAD KIT - see Figure 2-1**

**NOTE:** One Base Pad Kit is required for each Single, Double, or Triple Oven installation.

Item	Quantity				Part No.	Description
	Single oven with 19" leg extensions	Double oven with 15" leg extensions	Triple oven with 4" leg extensions	Triple oven without leg extensions		
1a	4	--	--	--	61838	Leg extension, 19" (483mm)
1b	--	4	--	--	61828	Leg extension, 15" (381mm)
1c	--	--	4	--	61839	Leg extension, 4" (102mm)
4	4	4	4	4	58930	Caster, swivel (with brake)
5	4	4	4	4	22450-0028	Adjustable foot, standard
6	1	1	1	1	22450-0253	Restraint cable, 60" (1524mm)
7	1	1	1	1	21392-0005	Eye bolt/lag screw
8	1	1	1	1	37210-0055	Base pad
--	2	2	2	2	35210-0656	Top cover (right or left)
--	8	8	8	8	21256-0069	Screw, sl trus hd #10-32 X 1-1/2"
--	16	16	16	--	21216-0018	Bolt, hex cap 1/2"-13 X 1-1/4"
--	16	16	16	--	21416-0003	Flat washer, 1/2"
--	16	16	16	--	21426-0004	Lock washer, 1/2"
--	--	--	--	--	A27727	Bolt, hex cap 3/8"-16 X 1"
--	--	--	--	--	A21924	Flat washer, 3/8"
--	--	--	--	--	21172-0004	Lock nut, hex, 3/8"-16
<b>ADDITIONAL COMPONENTS FOR GAS OVENS:</b>						
9	1	1	1	1	33120-0056	Gas pipe, 1-1/4" dia. X 54" (1372mm) L
10	2	2	2	2	27271-0004	Pipe clamp, 1-1/2"
11	2	2	2	2	33120-0055	Pipe nipple, 1-1/4" dia. X 3" (76mm) L, NPT
12	2	2	2	2	23122-0007	Elbow, 90°, 1-1/4" dia.
13	1	1	1	1	22361-0003	Gas hose, 1-1/4" dia. X 72" (1829mm) L
--	2	2	2	2	21292-0001	Screw, hex wshr hd #10-16 X 3/4"



## II. INSTALLATION KIT - see Figure 2-2

**NOTE:** One Installation Kit is required for each oven cavity.

ITEM	QTY	P/N	DESCRIPTION
1	1	55028	STOP,BACK SIDE CONV EXT
2	1	55027	STOP,SIDE END CONV EXT
3	1	59026	OWNER'S OPERATING & INSTALLATION MANUAL
4	1	42612	KIT,SUPPLEMENT SVC.AGENCY LIST
5	1	33120-0056	PIPE,BLK 1-1/4" X 54"
6	1	22450-0130	BAG,POLY4MIL 9" X 12"W/MINI-GRIP
7	1	59155	BUSHING,HEYCO SB 1500-18
8	1	59099	Reflector
9	1	59098	Bracket, Reflector
10	1	59226	WLDMT, Bracket Reflector
11	2	48522	Spacer, 1.5" Dia X 1.125" H
12	2	19A15144	SCR, MS HH 10-32 X 1-1/4 18-8

Fig. 2-2 - Installation Kit

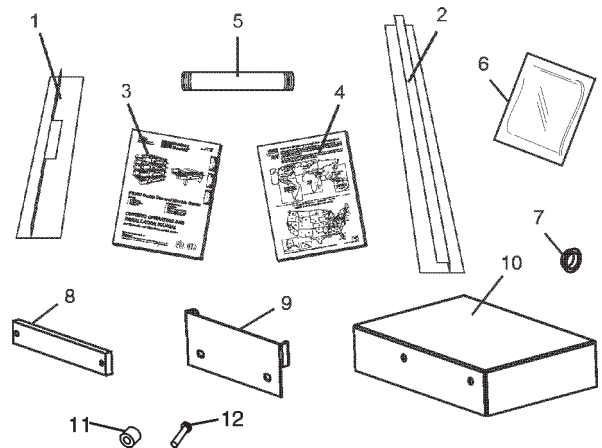

## III. VENTILATION SYSTEM

### IMPORTANT

Where national or local codes require the installation of fire suppression equipment or other supplementary equipment, DO NOT mount the equipment directly to the oven.

**MOUNTING SUCH EQUIPMENT ON THE OVEN MAY:**

- VOID AGENCY CERTIFICATIONS
- RESTRICT SERVICE ACCESS
- LEAD TO INCREASED SERVICE EXPENSES FOR THE OWNER

### A. Requirements

#### CAUTION

Gas oven installations REQUIRE a mechanically driven ventilation system with electrical exhaust air sensing control.

A mechanically driven ventilation system is STRONGLY RECOMMENDED for electric oven installations.

**PROPER VENTILATION OF THE OVEN IS THE RESPONSIBILITY OF THE OWNER.**

### B. Recommendations

NOTE THAT THE HOOD DIMENSIONS SHOWN IN FIGURE 2-3 ARE RECOMMENDATIONS ONLY. LOCAL, NATIONAL, AND INTERNATIONAL CODES MUST BE FOLLOWED WHEN INSTALLING THE VENTILATION SYSTEM. ANY APPLICABLE

CODES SUPERSEDE THE RECOMMENDATIONS SHOWN IN THIS MANUAL.

The rate of air flow exhausted through the ventilation system may vary depending on the oven configuration and hood design. Consult the hood manufacturer or ventilation engineer for these specifications.

To avoid a negative pressure condition in the kitchen area, return air must be brought back to replenish the air that was exhausted. A negative pressure in the kitchen can cause heat-related problems to the oven components as if there were no ventilation at all. The best method of supplying return air is through the heating, ventilation and air conditioning (HVAC) system. Through the HVAC system, the air can be temperature-controlled for summer and winter. Return air can also be brought in directly from outside the building, but detrimental effects can result from extreme seasonal hot and cold temperatures from the outdoors.

**NOTE:** Return air from the mechanically driven system must not blow at the opening of the baking chamber. Poor oven baking performance will result.

### C. Other ventilation concerns

- Special locations, conditions, or problems may require the services of a ventilation engineer or specialist.
- Inadequate ventilation can inhibit oven performance.
- It is recommended that the ventilation system and duct work be checked at prevailing intervals as specified by the hood manufacturer and/or HVAC engineer or specialist.

Fig. 2-3 - Ventilation System

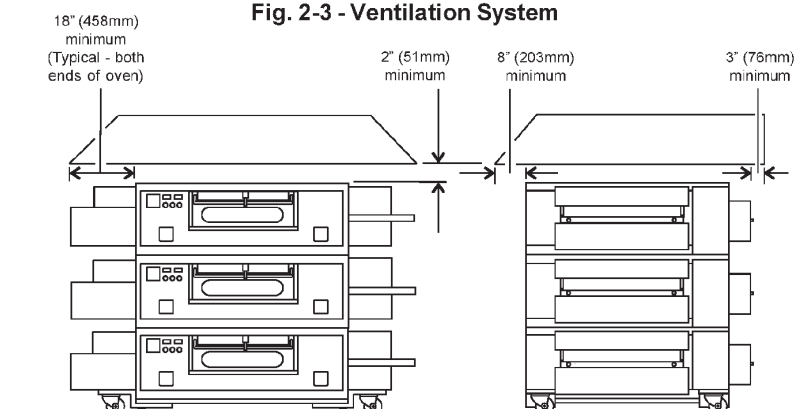

**IV. ASSEMBLY**

**A. Base Pad, Legs, Casters, and Stacking**

**NOTE:** Optional Stacking Lift Kit (P/N 30580)  
*The Stacking Lift Kit, P/N 30580, is available separately. This Kit provides a complete lift adapter set, specifically designed for stacking PS770 Series oven cavities. The Kit includes an instructional videotape.*

1. Install the top panels in place on the top oven cavity. Follow the instructions provided with the top panels.
- 2a. *Legs/Casters Installation (Standard) - Single Ovens, Double Ovens, and Triple Ovens with Leg Extensions*
  - Install one leg extension to each corner of the base pad using the supplied 1/2"-13x1-1/4" bolts, 1/2" flat washers, and 1/2" lockwashers. See Figure 2-4.
  - Install one adjustable foot and one caster into the holes on the bottom of the leg extension. The adjustable foot should be installed into the OUTSIDE hole (closest to the front or rear face of the oven). The caster should be installed into the INSIDE hole.

2b. *Legs/Casters Installation - Triple Ovens Without Leg Extensions*

Install one adjustable foot and one caster into the 3/4" holes on the bottom of the base pad. The adjustable foot should be installed into the OUTSIDE hole (closest to the front or rear face of the oven). The caster should be installed into the INSIDE hole. See Figure 2-5.

3. Install the base pad onto the lower oven cavity. Check that the eyebolt welded onto the pad faces the rear of the oven.
4. Stack the oven cavities. If necessary, refer to the instructional videotape provided with the Stacking Lift Kit (P/N 30580).

**B. Restraint Cable Installation**

Because the oven is equipped with casters, a restraint cable assembly must be installed to limit the movement of the appliance without depending on the connector and the quick disconnect device or its associated piping. One end of the cable is anchored to the eyebolt on the rear surface of the oven's base pad, while the other is anchored to the wall. See Figure 2-6.

After connecting the restraint cable, move the oven to its final location. Adjust the bottom (hex) sections of the feet so that the casters are off the floor. For quad ovens, lock the two front casters.

**C. Conveyor Installation**

**NOTE**  
*Split belt conveyors can only be installed from the end of the oven with the drive motor.*

*Single-belt conveyor assemblies may be inserted into either end of the oven. If it is to be installed from the end of the oven without the drive motor, the drive sprocket assembly must be removed.*

**Figure 2-4 - Legs and Casters - Standard**

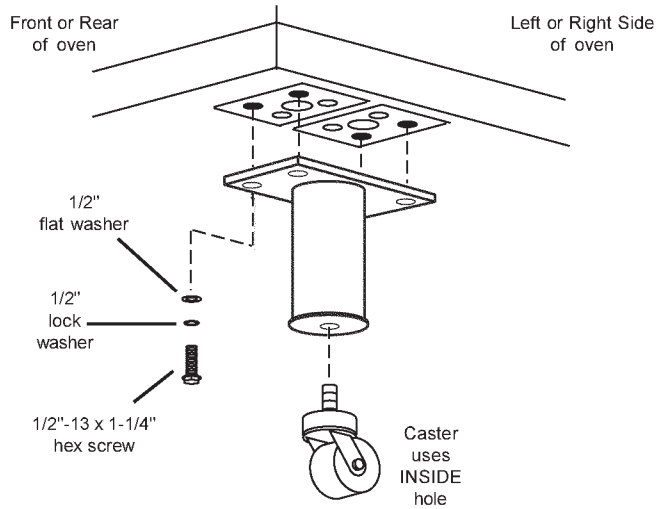

**Figure 2-5 - Legs and Casters for Triple Oven Without Leg Extensions**

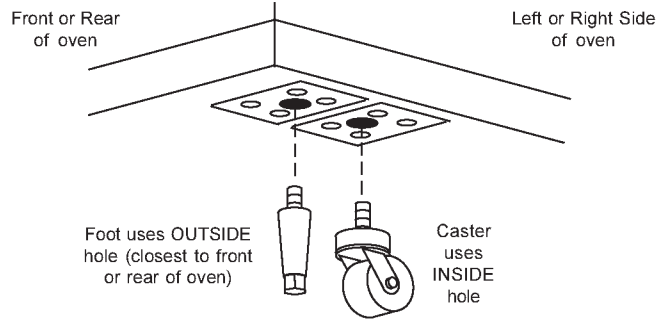

**Figure 2-6 - Installing the Restraint Cable**

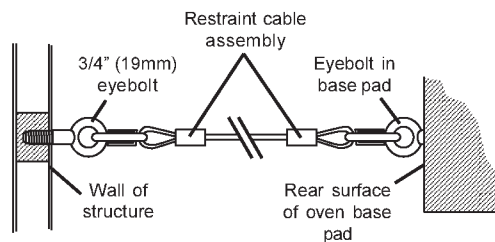

To remove the drive sprocket (if necessary), loosen the set screw on the conveyor collar as shown in Figure 2-7. Then, pull the sprocket assembly straight out.

1. Lift the conveyor and position it in the oven. See Figure 2-8.
2. Continue moving the conveyor into the oven until the frame protrudes equally from each end of the oven (about 18"/457mm).
3. Check that the retainers located on the underside of the conveyor frame rest firmly against the lower end plugs, as shown in Figure 2-8.
4. When the conveyor is positioned properly, check for freedom of movement of the conveyor belt by pulling it for about 2-3 feet (60 to 90 cm) with your fingers. The conveyor must move freely.
5. If the drive sprocket was removed when installing the conveyor, replace it at this time.
6. Install the drive chain between the conveyor drive sprocket and the motor sprocket. To install the chain, it will be necessary to lift the drive end of the conveyor slightly.
7. Install the conveyor drive motor cover.
8. Check the tension of the conveyor belt as shown in Figure 2-9. The belt should lift between 3-4" (75-100mm). **DO NOT OVERTIGHTEN THE CONVEYOR BELT.**

**NOTE:**

If necessary, the belt tension can be adjusted by turning the conveyor adjustment screws, located at the idler (right) end of the conveyor. See Figure 2-9.

9. If necessary, links can be added to or removed from the conveyor belt to achieve the correct deflection of 3-4" (75-100mm). If links must be removed from the belt, it can be reattached to the conveyor as follows:
  - a. The conveyor belt links must be oriented as shown in Figure 2-10.
  - b. The smooth side of the conveyor belt must face UP.
  - c. Connect the inside master links. Check that the links are oriented as shown in Figure 2-10.
  - d. Connect the outside master links. Note that the outside master links have right and left sides. The right-side master link has an open hook facing you, as shown in Figure 2-10.
  - e. Check for freedom of movement of the conveyor belt by pulling it for about 2-3 feet (60 to 90 cm) with your fingers. The conveyor must move freely.
  - f. Return to Step 8, above, to re-check the belt tension.

**Figure 2-9 - Checking the conveyor tension**

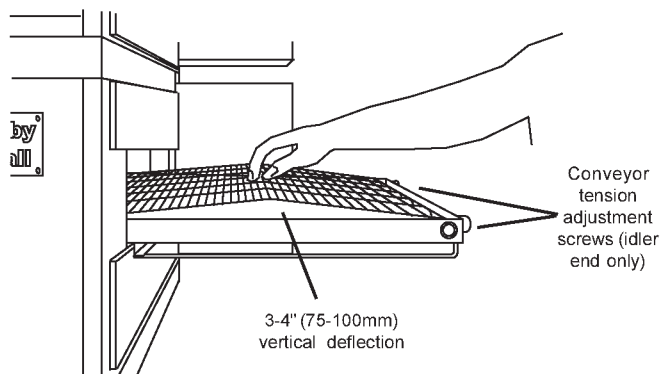

## D. STANDOFF INSTALLATION

- 1 Place screw, P/N 19A15144, through counter-bored hole in standoff, P/N 48522, and screw into weld nut on rear shroud.
2. Repeat procedure for both sides.

**Figure 2-7 - Removing the Conveyor Drive Sprocket**

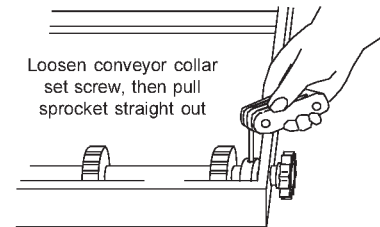

**Figure 2-8 - Inserting the Conveyor**

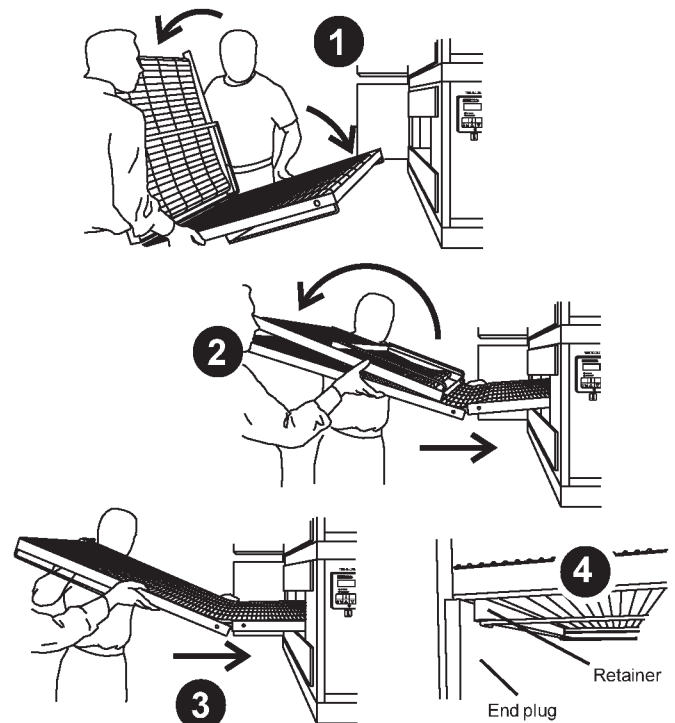

**Figure 2-10 - Conveyor and Master Link Orientation**

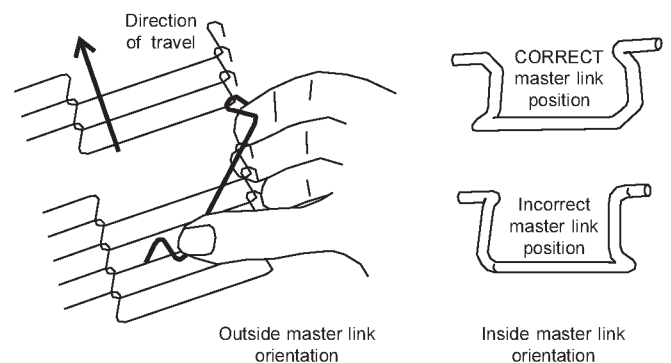

## V. FINAL ASSEMBLY

1. Install the crumb trays underneath the conveyor as shown in Figure 2- 11. First, place the inside edge of the tray onto the retainer (shown in Figure 2-8). Then, swing the outside edge of the tray up and into place.
2. Press the conveyor end stop and rear stop down over the edge of the conveyor frame. See Figure 1-1 (in Section 1, [Description](#)).

Figure 2-11 - Crumb trays

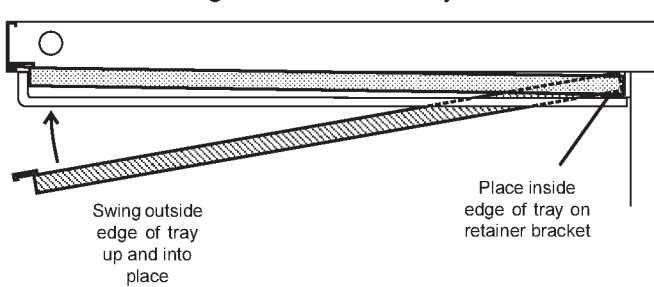

## ATTACHING THE POINT OF SALE CABLE

Remove the cable (P/N 59198) from the Kit. Attach the 90 degree plug to the rear of the touchscreen display and route the serial connector out the grommetted bottom hole and along the gas pipe. Connect the serial connector with the cable supplied by the customer.

## CONVEYOR BELT REVERSAL

Conveyor belt reversal consists of three steps:

1. Physically reversing the conveyor belt
2. Resetting direction jumper on the conveyor control board.
3. Switching the photo detector.

## REVERSING THE CONVEYOR BELT

Remove the conveyor from the oven and find the master link location. Remove master links and remove the belt from the conveyor frame. Reassemble the belt back onto the frame (in the reverse direction) and reinstall the master links. Replace the conveyor assembly in the oven.

## RESETTING DIRECTION JUMPER

Locate Jumper P1 on the conveyor control board. Move jumper from terminals 1 and 2, and replace onto terminals 2 and 3.

## SWITCHING PHOTO DETECTOR

Remove both rear fan belt covers, then remove the motor cover assembly from both sides of the oven. The photo eye is located on the front side of the left motor bracket. Disconnect the three connecting wires, noting which color wires assemble to the associated wires on the photo-detector. Remove the entire photo detector bracket. Replace the assembly to the right-hand side of the unit, mirroring the way it was assembled on the left. Reconnect the detector wiring in the same order it was on the left.

Mount the new reflector bracket to the provided holes on the front right-hand side of the oven. The reflector should be positioned just above the conveyor belt.

Using an assistant, hold both back cover switches in the closed position. This will allow power to the photo-eye, and it will provide a red beam for aiming. Loosen one of the screws holding the photo detector gimbal tight, allowing it to be reaimed at the reflector. The beam should hit exactly in the center of the reflector, then tighten the screw back down.

**Note:** This is MUCH easier in reduced light.

Replace all covers.

## VI. ELECTRICAL SUPPLY



### WARNING

Authorized supplier personnel normally accomplish the connections for the ventilation system, electric supply, and gas supply, as arranged by the customer. Following these connections, the factory-authorized installer can perform the initial startup of the oven.

**NOTE:** The electric supply installation must satisfy the requirements of the appropriate statutory authority, such as the National Electrical Code (NEC), ANSI/NFPA70, (U.S.A.); the Canadian Electrical Code, CSA C22.2; the Australian Code AG601; or other applicable regulations.

**NOTE:** The electric supply connection must meet all national and local electrical code requirements.

Check the oven serial plate before making any electric supply connections. Electric supply connections must agree with data on the oven serial plate. The location of the serial plate is shown in Figure 1-1 (in Section 1, [Description](#)).

A fused disconnect switch or a main circuit breaker (customer furnished) **MUST** be installed in the electric supply line for each oven cavity. It is recommended that this switch/circuit breaker have lockout/tagout capability.

The supply conductors must be of the size and material (copper) recommended. Refer to the wiring diagram inside the machinery compartment of the oven. Electrical specifications are also listed on the oven's serial plate and in Table 1-3, [Electrical Specifications](#) (in Section 1, [Description](#)).

The oven requires a ground connection to the oven ground screw. For gas ovens, the ground screw is located in the electrical junction box (see Figure 2-12). If necessary, have the electrician supply the ground wire. **Do NOT use the wiring conduit or other piping for ground connections!**

Incoming electrical power lines are fed through the strain-relief fitting, shown in Figure 2-12. The electrical supply connections are made inside the electrical junction box. The power lines then connect to the oven circuits through safety switches located inside the machinery compartment and each blower motor compartment. These switches interrupt electrical power to the oven when the Machinery Compartment Access Panel is opened, OR when either of the blower or rear shrouds is removed.

## Connection

Refer to the wiring diagram inside the machinery compartment of the oven to determine the correct connections for the electrical supply lines. Connect the supply as indicated on the wiring diagram.

## CAUTION

The terms of the oven's warranty require all start-ups, conversions and service work to be performed by a Middleby Marshall Authorized Service Agent.

Figure 2-12 - Utility Connection Locations for Gas Ovens

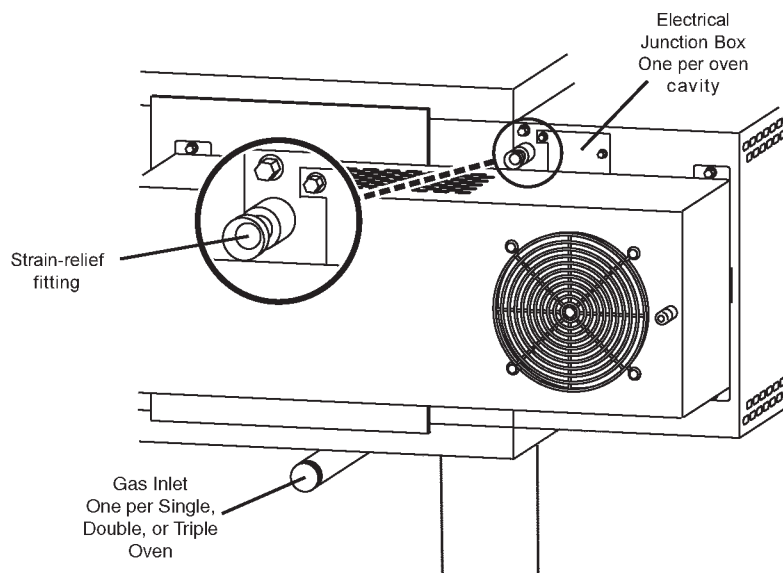

## VII. GAS SUPPLY

### CAUTION

DURING PRESSURE TESTING NOTE ONE OF THE FOLLOWING:

1. The oven and its individual shutoff valve must be disconnected from the gas supply piping system during any pressure testing of that system at test pressure in excess of 1/2 psi (3.45 kPa).
2. The oven must be isolated from the gas supply piping system by closing its individual manual shutoff valve during any pressure testing of the gas supply piping system at test pressure equal to or less than 1/2 psi (3.45 kPa).

3. If incoming pressure is over 14" W.C. (35mbar), a separate regulator **MUST** be installed in the line **BEFORE** the individual shutoff valve for the oven.

**WARNING:** To prevent damage to the control valve regulator during initial turn-on of gas, it is very important to open the manual shutoff valve very slowly.

After the initial gas turn-on, the manual shutoff valve must remain open except during pressure testing as outlined in the above steps or when necessary during service maintenance.

### A. Gas Utility Rough-In Recommendations

The following gas system specifications are **STRONGLY RECOMMENDED**. Deviating from these recommendations may affect the baking performance of the oven.

#### Gas Meter

- One or two oven cavities: 750 cfh meter
- Three oven cavities: 1200 cfh meter

#### Gas Line

- DEDICATED LINE from the gas meter to the oven
- 2" (50.8mm) pipe for natural gas
- 2" (50.8mm) pipe for propane
- Maximum length: 200' (61m). Each 90° elbow equals 7' (2.13m) of pipe.

SECTION 2-INSTALLATION

**B. Connection**

Check the oven's gas supply requirements before making the gas utility connection. Gas supply requirements are listed on the oven's serial plate and in Table 1-4, Gas Orifice and Pressure Specifications (in Section 1, Description).

Check the serial plate to determine the type of gas (Propane or Natural) to be used with the oven.

Refer to the instructions in the gas hose package (included in the Installation Kit) before connecting the gas line. One gas line connection method is shown in Figure 2-13; however, compliance with the applicable standards and regulations is mandatory.

Inlet, regulated, and pilot gas pressure readings can be taken using a "U" tube manometer at the tap locations shown in Figure 2-14.

**NOTE**

*The installation must conform with local codes or in the absence of local codes, with the National Fuel Gas Code, ANSI Z223.1-latest edition.*

Certain safety code requirements exist for the installation of gas ovens; refer to the beginning of Section 2 for a list of the installation standards. In addition, because a the oven is equipped with casters, the gas line connection shall be made with a connector that complies with the Standard for Connectors for Movable Gas Appliances, ANSI Z21.69 (in U.S.A.), as well as a quick-disconnect device that complies with the Standard for Quick-Disconnect Devices for Use With Gas Fuel, ANSI Z21.41 (in U.S.A.).

**C. Gas Conversion**

Where permitted by local and national codes, it is possible to convert ovens from natural to propane gas, or from propane to natural gas. Use the appropriate Middleby Marshall Gas Conversion Kit for the specific oven model.

**CAUTION**

*The terms of the oven's warranty require all start-ups, conversions and service work to be performed by a Middleby Marshall Authorized Service Agent.*

**D. PS770 Propane conversion**

Four items have to be changed, to change the oven to LP:

1. Adjust internal burner air shutters.
2. Replace main Orifices
3. Replace (and adjust) the spring in the main valve (see LP kit)
4. Adjust modulating valve bypass settings.

Disconnect the manifold unions closest to the main burner, and remove the manifold assemblies (four screws each). Remove the addition four screws holding the burner cores and slide out each burner core (leaving the ignition and sense wires connected). Adjust the internal air shutters fully open, and replace the cores.

Replace the main orifices on the manifold assemblies with the LP units, and replace the manifold assemblies. Reconnect the unions. Replace the valve spring with the LP spring, and adjust the downstream pressure to get 7" WC.

Adjust the bypass screws in the side of each modulating valve to approximately 1/6 turn from fully closed. If this setting is too low, the burners will shut off when trying to modulate. If it is too open, the unit will tend to gradually raise up in temperature at standby.

**Figure 2-13 - Flexible Gas Hose Installation**

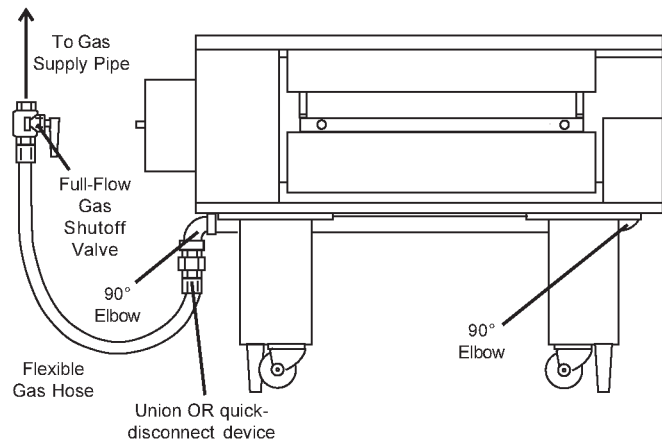

**Figure 2-14 - Gas Burner/Blower Motor and Piping Assembly**

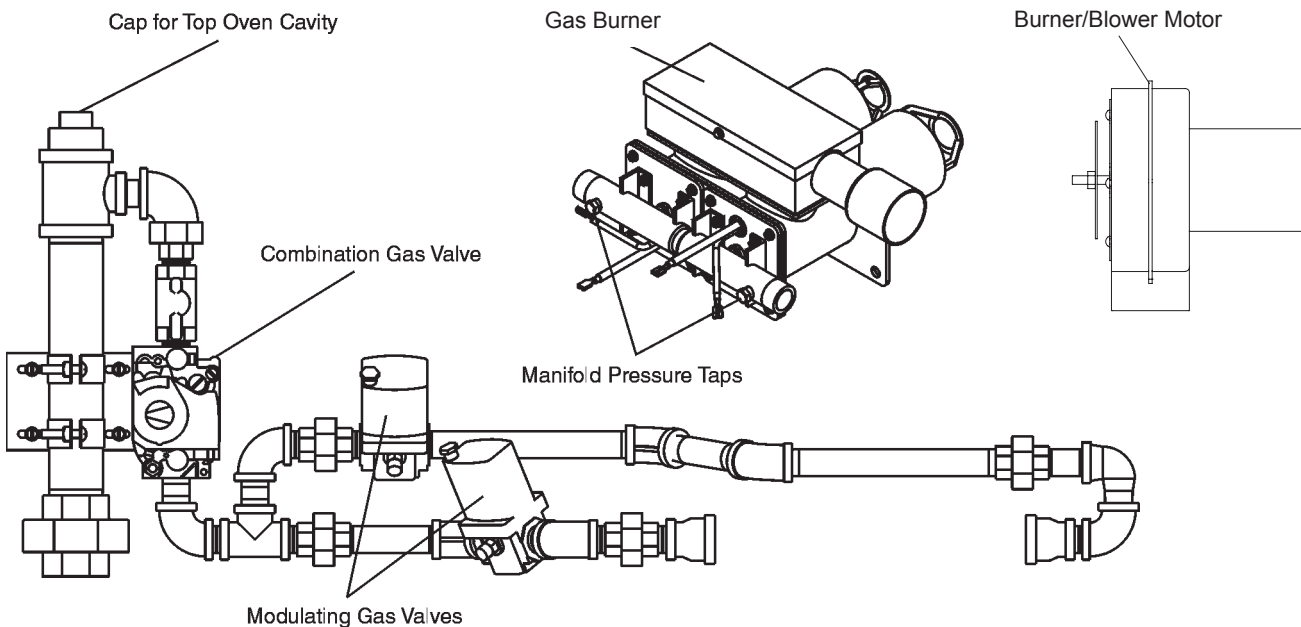

## SECTION 3 - OPERATION

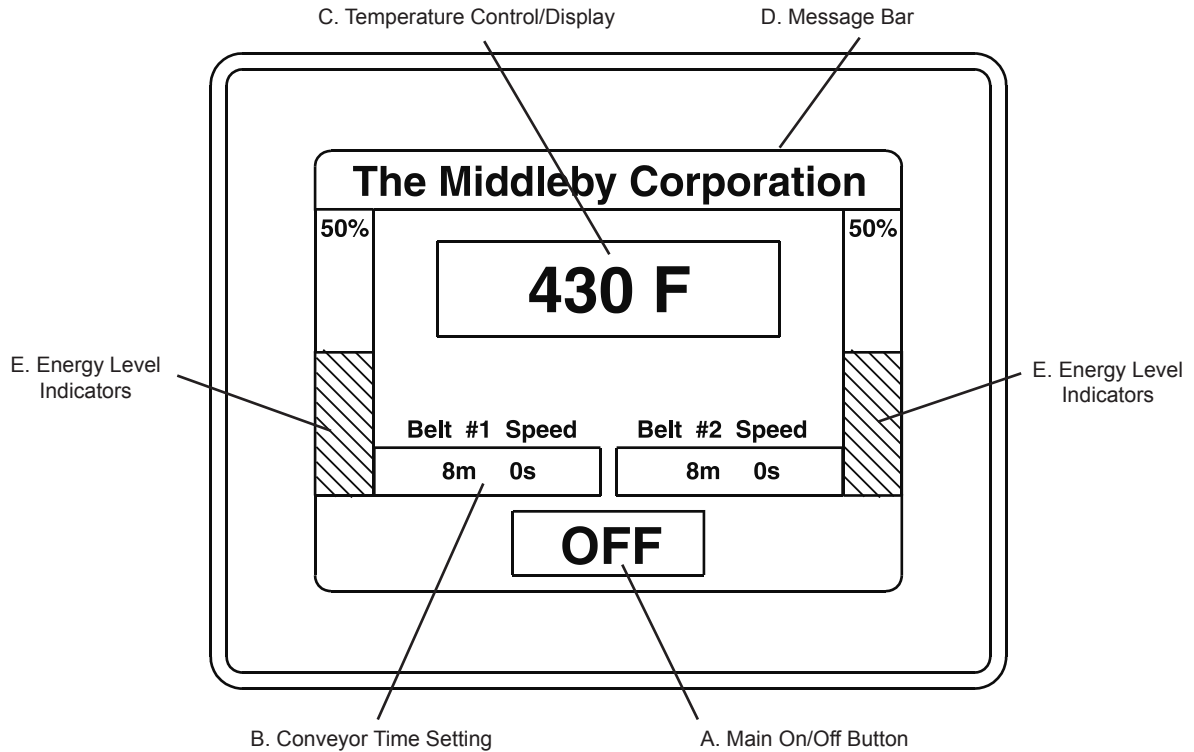

### I. LOCATION AND DESCRIPTION OF CONTROLS

#### A. Main On/Off Button

Turns all oven functions on or off. If the oven is below the set point, it will rise to the set point and turn the conveyor on. If it is turned off and the oven is above 200° F, the blowers will remain on until the oven drops below 200° F.

#### B. Conveyor Time Setting

Adjusts and displays the conveyor bake time. Dual belt ovens have two displays, single units have one.

#### C. Temperature Control/Display

Displays the average set point of both right and left sides of the oven. Pressing on the display allows individual temperature displays and adjustments.

#### D. Message Bar

Displays messages during oven operation.

#### E. Energy Level Indicators

Displays energy usage on left and right sides of the oven.

## II. NORMAL OPERATION - STEP-BY-STEP-

### A. Daily Startup Procedure

1. Check that the circuit breaker/fused disconnect is in the On position. Check that the window is closed. The touch panel display should be lit.
2. Adjust the conveyor to the desired bake time.
3. Press the temperature button to display right and left hand oven settings. Set temperatures as desired.
4. Press the ON button to activate the oven. The conveyor will not run, until the oven temperature has reached the set points.

### B. Daily Shutdown Procedure

1. Make certain there are no products left on the conveyor in the oven.
2. Press the ON square to turn the oven off.
3. Open the window to allow the oven to cool faster.
4. After the oven has cooled and the blowers have turned off, the circuit breaker/fused disconnect may be turned off.

### Quick Reference – Touch Screen Controller

#### A. Main Screen

1. On/Off button - Used to turn oven On and Off.
2. Conveyor speed - Pressing on either the minutes or seconds allows a new value to be input for the conveyor speed. Split belt ovens have two inputs (front and rear belts).
3. Oven temperature - Pressing on the set temperature shifts the user to the oven temperature set point/indicator screen.
4. Energy level indicators - Indicators to either side of the screen indicate the energy input to that side of the oven.
5. Message bar - Indicates various messages pertaining to current oven conditions.

#### B. Oven Temperature/Set Point/Indicator Screen

1. Right actual temperature - Indicates current average temperature of the right side of the oven.
2. Left actual temperature - Indicates current average temperature of the left side of the oven.

**NOTE:** Right to Left temperature settings should not exceed a differential of 20 °F.

3. Right Set point temperature - Pressing on this value allows the user to adjust the set point for the right side of the oven.
4. Left Set point temperature - Pressing on this value allows the user to adjust the set point for the left side of the oven.
5. Exit - Returns to the main screen.

### C. Energy Mode Screen

1. Mode Two - Pressing this button allows the user to set the amount of time that the oven allows before shifting from energy mode 1 to energy mode 2. Setting this value to zero disables this energy mode.
2. Mode Three - Pressing this button allows the user to set the amount of time that the oven allows before shifting from energy mode 2 to energy mode 3. Setting this value to zero disables this energy mode.
3. Mode Four - Pressing this button allows the user to set the amount of time that the oven allows before shifting from energy mode 3 to oven off. Setting this value to zero disables this energy mode.

### Energy Modes

Energy Mode One - This mode is automatic, and starts (bake time +1 minute) after the last product has entered the oven. In this mode, the main oven blowers will lower to 1500 RPM, while the oven maintains temperature and belt speed.

Energy Mode Two - The oven lowers its set point by 100° F, and stops the belt. Anytime that the oven is more than 10 degrees over its set point, the burners will completely shut off, allowing the oven to cool and the burners are on minimum flow. The main blowers will continue to run at 1500 RPM in this mode. Placing any article on the input belt will cause normal operation of the oven to resume, and bring the set point back to its original level. The belt will resume operation once both sides of the oven are within 5° F of the set point.

Energy Mode Three - The oven will turn off completely and shut off the circulation blowers once the oven temperature has dropped below 200° F. Placing any article on the input belt will cause normal operation of the oven to resume, and bring the set point back to its original level. The belt will resume operation once both sides of the over are within 5° F of the set point.

Energy Mode Four - This is a complete oven shut down. Placing anything on the belt will NOT return the oven to Operation. The ON button on the main screen has to be pressed to restart the oven.



### III. QUICK REFERENCE: TROUBLESHOOTING

SYMPTOM	PROBLEM	SOLUTION
<i>Oven will not turn On.</i>	No electrical power	<ul style="list-style-type: none"> <li>Check that the circuit breaker/fused disconnect is on. Make sure the emergent stop button is on.</li> </ul>
<i>Oven will not heat.</i>	No gas pressure	<ul style="list-style-type: none"> <li>Make sure main gas is on.</li> </ul>
	Burner did not light	<ul style="list-style-type: none"> <li>Turn oven off, and restart. If it still does not light, call for service.</li> </ul>
<i>Oven is operating, but little or no air is coming from the fingers.</i>	Air fingers may be assembled incorrectly after cleaning.	<ul style="list-style-type: none"> <li>Turn oven off, and allow to cool. Reassemble fingers correctly.</li> </ul>
<i>Conveyor will not move.</i>	Oven is not up to operating temperature.	<ul style="list-style-type: none"> <li>Allow oven to preheat.</li> </ul>
	Conveyor may be jammed.	<ul style="list-style-type: none"> <li>Turn oven off, and allow to cool. Check conveyor for blockage.</li> </ul>

### SCREEN ALERTS

SYMPTOM	PROBLEM	SOLUTION
Battery Symbol in the lower right hand corner	The internal battery needs to be replaced to retain energy mode timings.	<ul style="list-style-type: none"> <li>A qualified service technician should accomplish this.</li> </ul>
High Control Compartment Temperature	Clean and replace the front fan filters.	<ul style="list-style-type: none"> <li>Failure to do this will eventually shut down the oven due to excessive temperature.</li> </ul>
Main Blower problem or Combustion Blower problem.	The computer has detected a problem with either the main, or burner blowers.	<ul style="list-style-type: none"> <li>This should be corrected by a qualified service technician.</li> </ul>

# SECTION 4 - MAINTENANCE

## WARNING

Before ANY cleaning or servicing of the oven, perform the following procedure:

1. Switch off the oven and allow it to cool. Do NOT service the oven while it is warm.
2. Turn off the electric supply circuit breaker(s) and disconnect the electric supply to the oven.
3. If it is necessary to move the oven for cleaning or servicing, disconnect the gas supply connection before moving the oven.

When all cleaning and servicing is complete:

- |   |   |
|---|---|
| <ol style="list-style-type: none"> <li>1. If the oven was moved for servicing, return the oven to its original location.</li> <li>2. For gas ovens, reconnect the gas supply.</li> <li>3. Reconnect the electrical supply.</li> <li>4. If the restraint cable was disconnected to clean or service</li> </ol> | <ol style="list-style-type: none"> <li>5. For gas ovens, turn on the full-flow gas safety valve. Test the gas line connections for leaks using approved leak test substances or thick soap suds.</li> <li>6. Turn on the electric supply circuit breaker(s).</li> <li>7. Perform the normal startup procedure.</li> </ol> |
|---|---|

## WARNING

Possibility of injury from moving parts and electrical shock exists in this oven. Switch off and lockout/tagout the electric supply BEFORE beginning to disassemble, clean, or service any oven. Never disassemble or clean an oven with the BLOWER (⊗) switch or any other circuit of the oven switched on.

## CAUTION

NEVER use a water hose or pressurized steam-cleaning equipment when cleaning this oven. DO NOT use excessive amounts of water, to avoid saturating the oven insulation. DO NOT use a caustic oven cleaner, which can damage the aluminized bake chamber surfaces.

## NOTE

ANY replacement parts that require access to the interior of the oven may ONLY be replaced by a Middleby Marshall Authorized Service Agent. It is also strongly recommended that the 3-Month Maintenance and 6-Month Maintenance procedures in this section be performed ONLY by a Middleby Marshall Authorized Service Agent.

### I. MAINTENANCE - DAILY

- A. Check that the oven is cool and the power is disconnected, as described in the warning at the beginning of this Section.
- B. Clean the outside of the oven with a soft cloth and mild detergent.
- C. Clean the front cooling fans, as follows:
  - Snap off the protective grille, and wipe it clean with a cloth. See Figure 4-1.
  - Remove the foam filter and inspect it. If it is dusty, shake it briskly. If dirt or grease is present on the filter, wash it in warm, soapy water. Rinse the filter, squeeze it to remove as much of the water as possible, and then set it aside to dry thoroughly before reinstallation.
  - Once the filter is dry, reinstall the filter and grille.
- D. Clean the motor shroud and rear grills using a stiff nylon brush. Refer to Figure 4-2 for the locations of the grills.
- E. Check that ALL cooling fans are operating properly.

#### CAUTION

*If a cooling fan is not operating correctly, it must be replaced IMMEDIATELY. Operating the oven without adequate cooling can damage the oven's internal components.*

- F. Clean the conveyor belts with a stiff nylon brush. This is more easily accomplished by allowing the conveyor to run while you stand at the exit end of the conveyor. Then, brush the crumbs off the conveyor as it moves.
- G. Remove and clean the crumb trays. When reinstalling the trays, refer to Figure 2-12 (in Section 2, [Installation](#)).

Figure 4-1 - Front Cooling Fans

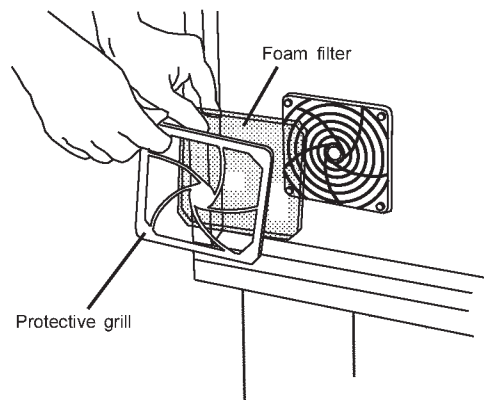
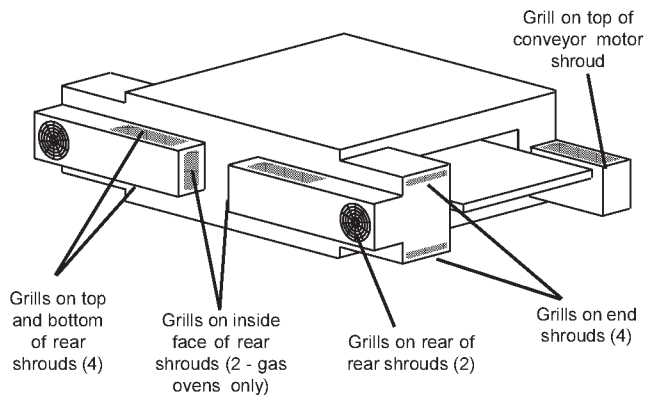

Figure 4-2 - Rear Grills and Motor Shroud Grill



## II. MAINTENANCE - MONTHLY

### NOTE

When removing the conveyor, refer to Figure 2-9 (in Section 2, *Installation*).

- A. Check that the oven is cool and the power is disconnected, as described in the warning at the beginning of this Section.
- B. Remove the crumb trays and drive motor shroud from the oven.
- C. Lift the drive end of the conveyor slightly, and push it forward into the oven. This removes the tension from the drive chain. Then, remove the drive chain from the conveyor sprocket.
- D. Slide the conveyor out of the oven, folding it as it is removed.
- E. Remove the end plugs from the oven. The end plugs are shown in Figure 1-1 (in Section 1, *Description*).
- F. Slide the air fingers and blank plates out of the oven, as shown in Figure 4-3. AS EACH FINGER OR PLATE IS REMOVED, WRITE A "LOCATION CODE" ON IT WITH A MARKER to make sure that it can be reinstalled correctly.

Example of markings:

(Top Row)      T1   T2   T3   T4   T5   T6

(Bottom Row)   B1   B2   B3   B4   B5   B6

- G. Disassemble the air fingers as shown in Figure 4-4. AS EACH FINGER IS DISASSEMBLED, WRITE THE "LOCATION CODE" FOR THE FINGER ON ALL THREE OF ITS PIECES. This will help you in correctly reassembling the air fingers.

### CAUTION

*Incorrect reassembly of the air fingers will change the baking properties of the oven.*

- H. Clean the air finger components and the interior of the baking chamber using a vacuum cleaner and a damp cloth. Refer to the boxed warnings at the beginning of this Section for cleaning precautions.
- I. Reassemble the air fingers. Then, replace them in the oven, using the "location code" as a guide.
- J. Replace the end plugs on the oven.
- K. Reassemble the conveyor into the oven. If the drive sprocket was removed when installing the conveyor, replace it at this time.
- L. Reattach the drive chain.
- M. Check the tension of the conveyor belt as shown in Figure 2-10 (in Section 2, *Installation*). The belt should lift between 3-4" (75-100mm). DO NOT OVERTIGHTEN THE CONVEYOR BELT. If necessary, the belt tension can be adjusted by turning the conveyor adjustment screws, located at the idler (right) end of the conveyor.
- N. Replace the crumb trays and drive motor shroud.

Figure 4-3 - Removing Air Fingers and Plates

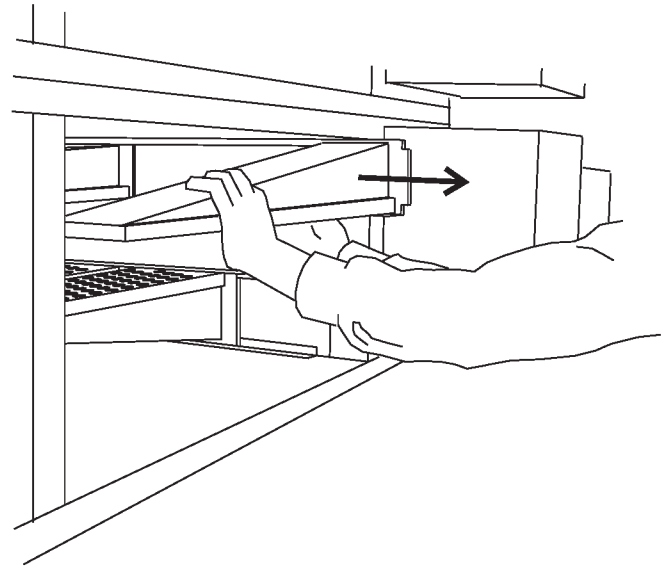
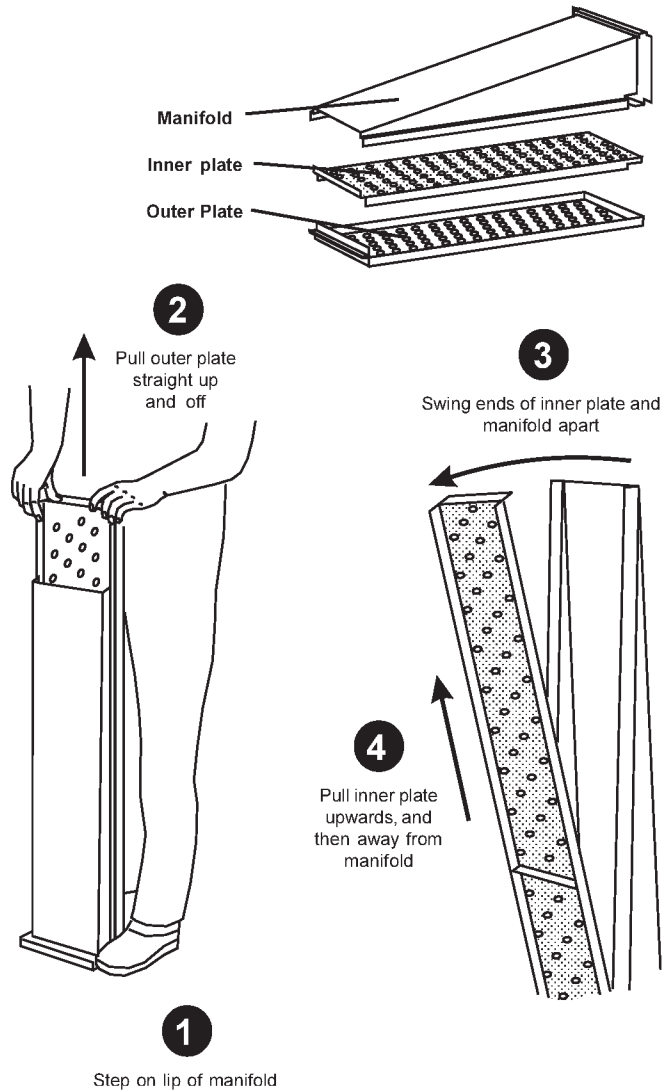

Figure 4-4 - Disassembling the Air Fingers



### III. MAINTENANCE - EVERY 3 MONTHS

- A. Check that the oven is cool and the power is disconnected, as described in the warning at the beginning of this Section.
- B. Vacuum both of the blower motors, and their surrounding compartments, using a shop vacuum.
- C. Tighten all electrical control terminal screws.

#### D. Split Belt Disassembly and Cleaning

For split belt ovens ONLY, disassemble, clean and lubricate the conveyor shaft components as described below.

1. Remove the motor shroud, conveyor extensions, and conveyor as described in Part II, [Monthly Maintenance](#).
2. Remove the master links from each conveyor belt. Then, roll the belts up along the length of the conveyor to remove them from the frame.
3. Remove the two conveyor adjustment screws from the idler end of the conveyor frame, as shown in Figure 4-5.
4. Remove the idler shaft assembly from the conveyor.
5. Pull apart the two sections of the idler shaft. Clean the shafts thoroughly using a rag. Then, lubricate both the extended shaft and the interior of the hollow shaft using an FDA-approved light food-grade lubricant.

#### CAUTION

*DO NOT lubricate the shafts using WD40 or a similar product. This can cause the shafts to wear rapidly.*

6. Before reassembling the shafts into the conveyor frame, check that they are oriented properly. Remember that unequal-width split belt ovens should ALWAYS have the narrower belt at the front of the oven.
7. Reassemble the idler shaft into the conveyor. Make sure that the bronze washer is in place between the two sections of the shaft. See Figure 4-7.
8. Replace the conveyor adjustment screws as shown in Figure 4-5. To allow the conveyor belt to be reinstalled later, do not tighten the screws at this time.
9. Loosen the set screw on both of the conveyor drive sprockets. Then, remove the sprockets from the shaft.
10. Loosen the locking collar set screw, as shown in Figure 4-6.
11. Push the drive shaft to the right, then lift it free of the conveyor frame. Then, disassemble and lubricate the two sections of the drive shaft as described in Step 5.
12. Before reassembling the shafts into the conveyor frame, check that they are oriented properly. Remember that unequal-width split belt ovens should ALWAYS have the narrower belt at the front of the oven.
13. Reassemble the drive shaft into the conveyor. Check that the nylon spacer is in place, as shown in Figure 4-7. Also, check that the bronze washer is in place between the two sections of the shaft.
14. Replace the drive sprockets. Reassemble the belts and master links onto the conveyor, and replace the conveyor in the oven.
15. Reassemble the motor shroud and conveyor extensions onto the oven.

16. Check the tension of the conveyor belt. The belt should lift between 3-4" (75-100mm). If necessary, adjust the belt tension by turning the conveyor adjustment screws.

Figure 4-5 - Split Belt Idler Shaft

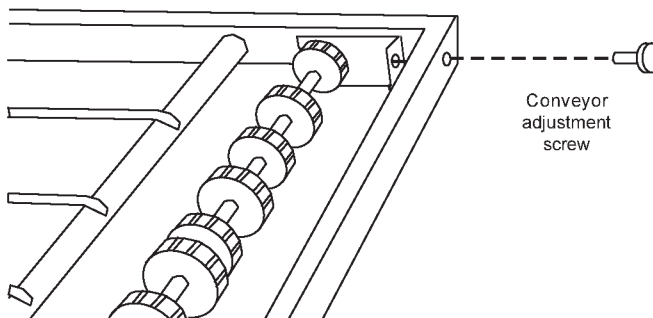

Figure 4-6 - Split Belt Drive Shaft

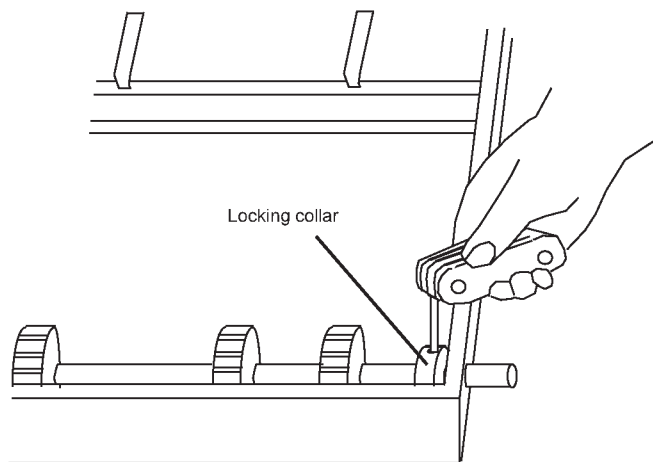
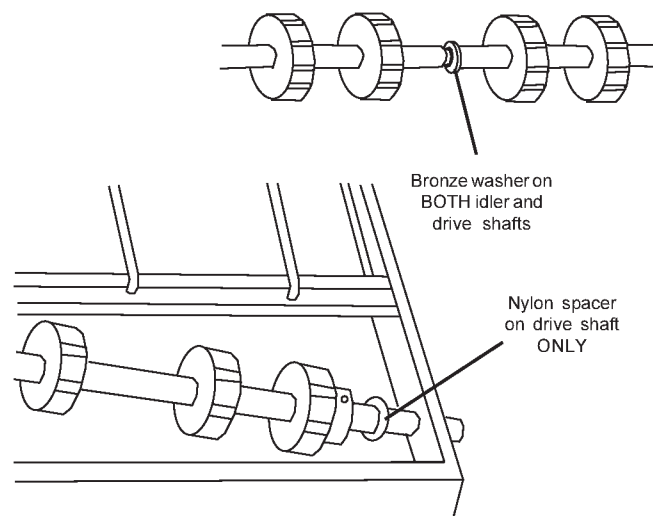

Figure 4-7 - Washer and Spacer



**E. Blower Belts**

1. To gain access to each blower belt compartment remove the four screws shown in Figure 4-8. Then, lift the rear shroud off its hangers.

If access to the blower motors is required, remove the three mounting screws (two on the front of each shroud and one on the rear). Then, lift the end shroud straight up and off its hangers.

2. Check each blower belt for cracking or excessive wear.
3. Check for amount of belt deflection in the center of the belt, 1/2" deflection is acceptable, see Figure 4-9.
4. If necessary, replace belt.

**IV. MAINTENANCE - EVERY 6 MONTHS**

- A. Check that the oven is cool and the power is disconnected as described in the warning at the beginning of this Section.
- B. For gas ovens, clean and inspect the burner nozzle and electrode assembly.
- C. Check (and clean, if necessary) the oven venting system.
- D. Check the conveyor drive shaft bushings and spacers. Replace the components if they are worn.

**Figure 4-8 - Rear Shrouds and Guard Plates**

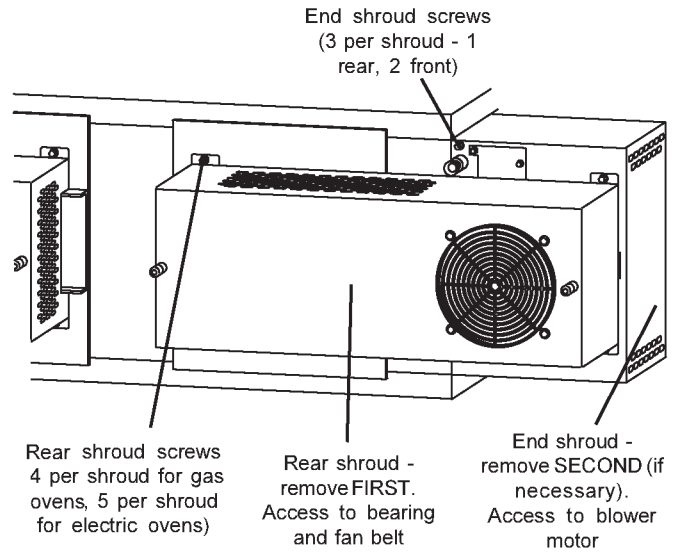

**Figure 4-9 - Belt Deflection**

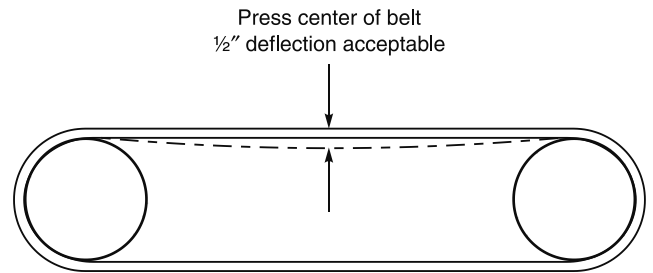

**V. KEY SPARE PARTS - Available separately. See Figure 4-9.**

ITEM	QTY.	P/N	DESCRIPTION
1	1	61561	DISPLAY, GT32 COLOR
2	1	58678	MOTOR, CONVEYOR DRIVE
3	1	58679	CONVEYOR CONTROL BOARD
4	2	59169	INVERTER, PROGRAMMED
5	1	M9608	POWER SUPPLY
6	1	59047	KIT, THERMOCOUPLE (5 THERMOCOUPLES)
7	2	M9616	FAN, COOLING
8	2	57288	MOTOR, BLOWER
9A	1	60837	AIR SWITCH BURNER/BLOWER MOTOR
9B	2	60598	SWITCH, AIR_13" WC
10	1	54727	IGNITION MODULE
11	1	M9887	ASSEMBLY, BURNER BLOWER/MOTOR
12	2	60539	VALVE, MODULATING GAS, 1/2"
13	2	31651	AMPLIFIER, MODULATING VALVE
14	1	33983	HIGH LIMIT CONTROL MODULE, 240V
15	2	32108	TRANSFORMER, 240Vp:24Vs
16	1	59082	PLC MODULE, PROGRAMMED
17	1	58668	THERMOCOUPLE MODULE
18	1	58669	CURRENT MODULE
19	1	59112	PHOTOCELL

**Fig. 4-9 - Key Spare Parts**

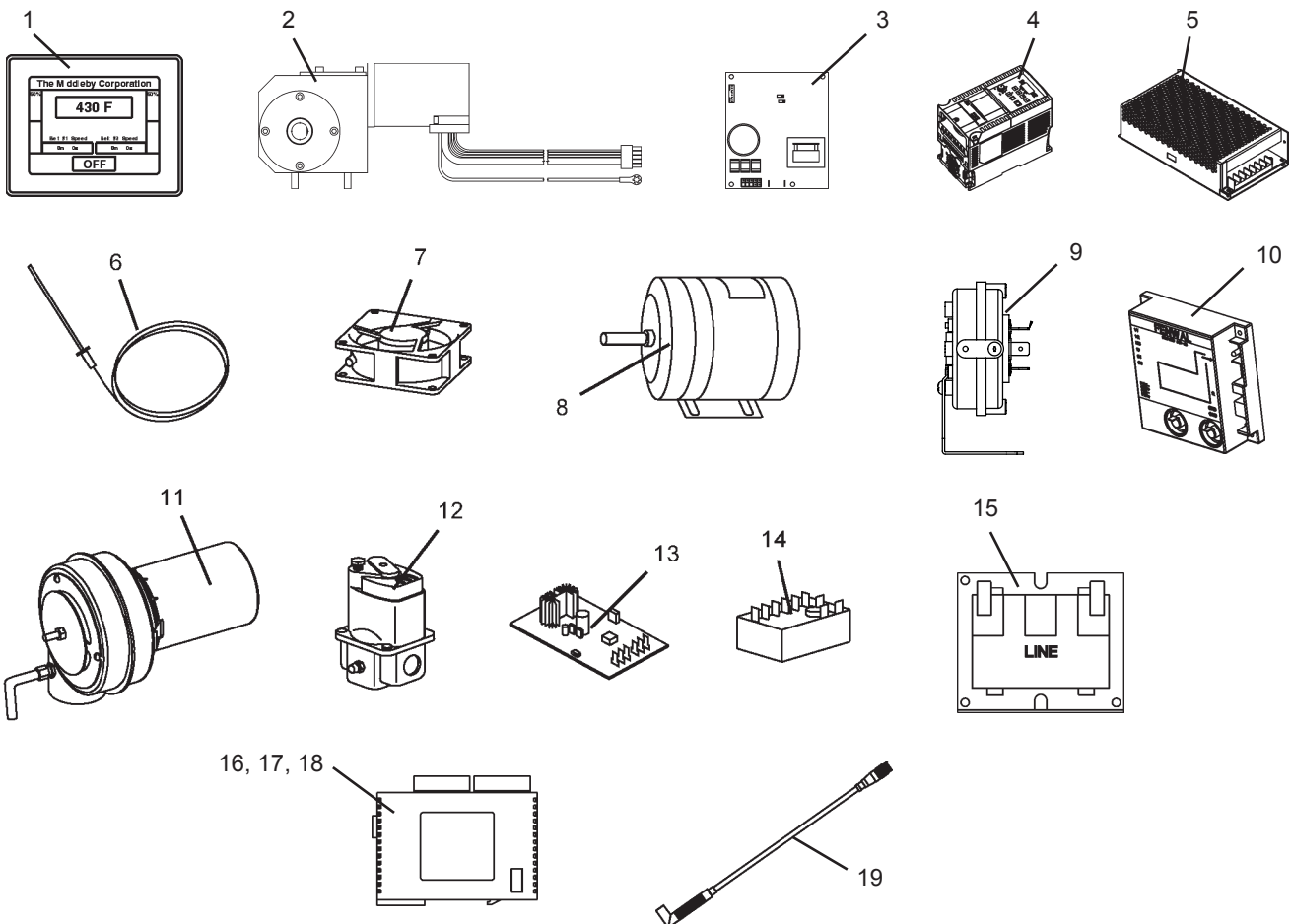

# Wiring Diagrams (electrical schematics)

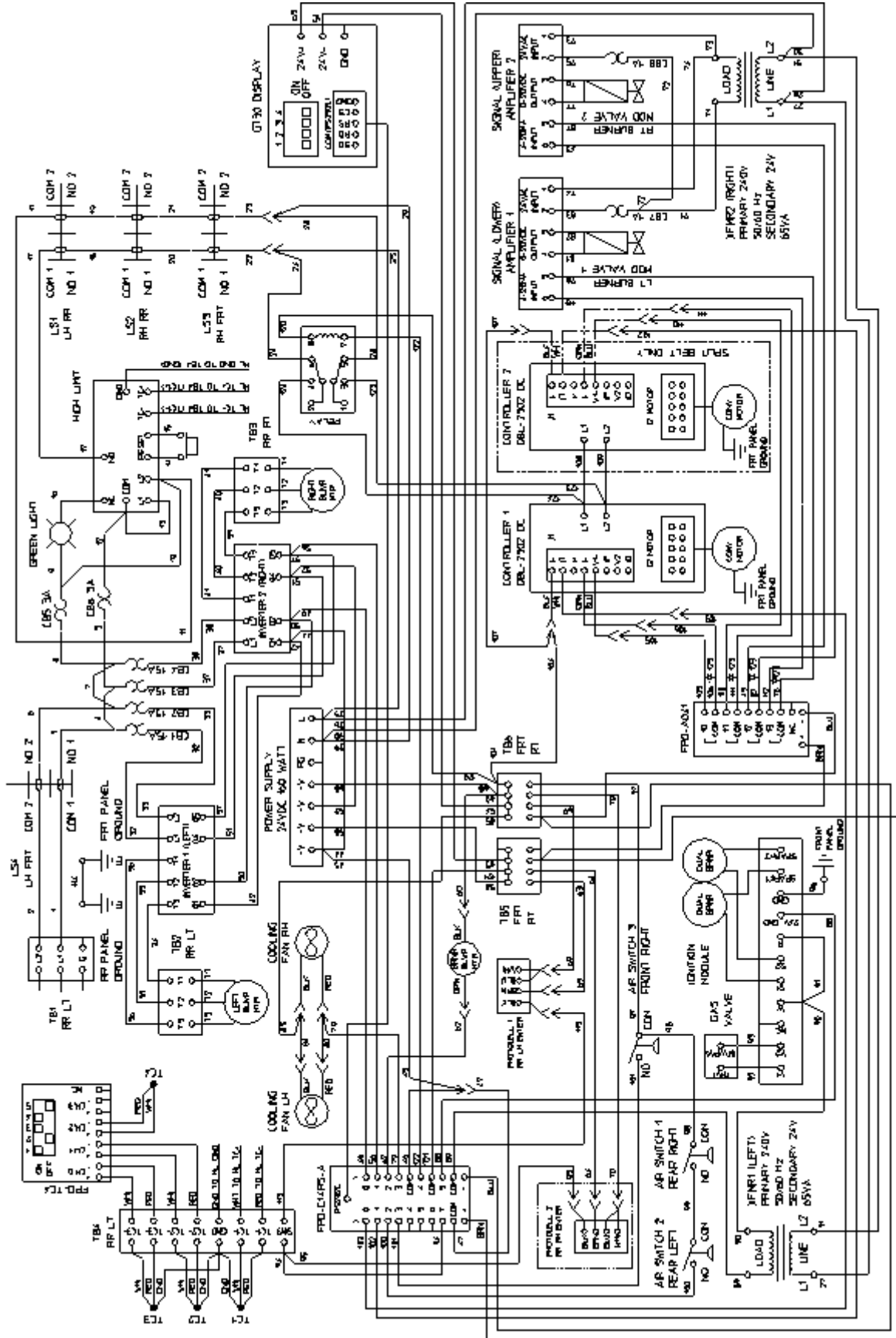

54745 Rev. J

Middleby-Marshall Model Number G208-240 volt 50/60 Hz, 1 Phase

Middleby Cooking Systems Group • 1400 Toastmaster Drive • Elgin, IL 60120 • USA • (847)741-3300 • FAX (847)741-4406



[www.middleby.com](http://www.middleby.com)

