



# Owner's Manual

**IMPORTANT FOR FUTURE REFERENCE**  
 Please complete this information and retain this manual for the life of the equipment:  
 Model #: \_\_\_\_\_  
 Serial #: \_\_\_\_\_  
 Date Purchased: \_\_\_\_\_

# Platinum Series Range

Flush Open Burner Models  
 Step-Up Open Burner Models  
 Combination Open-Burner Hot-Top Models  
 Combination Open-Burner Griddle Models

Graduated Hot-Top Models  
 Uniform Hot-Top Models  
 Plancha Models  
 French Top Models

Charbroiler Models  
 Standard Griddle Models  
 Thermostatic Griddle Models  
 Wood Smoker

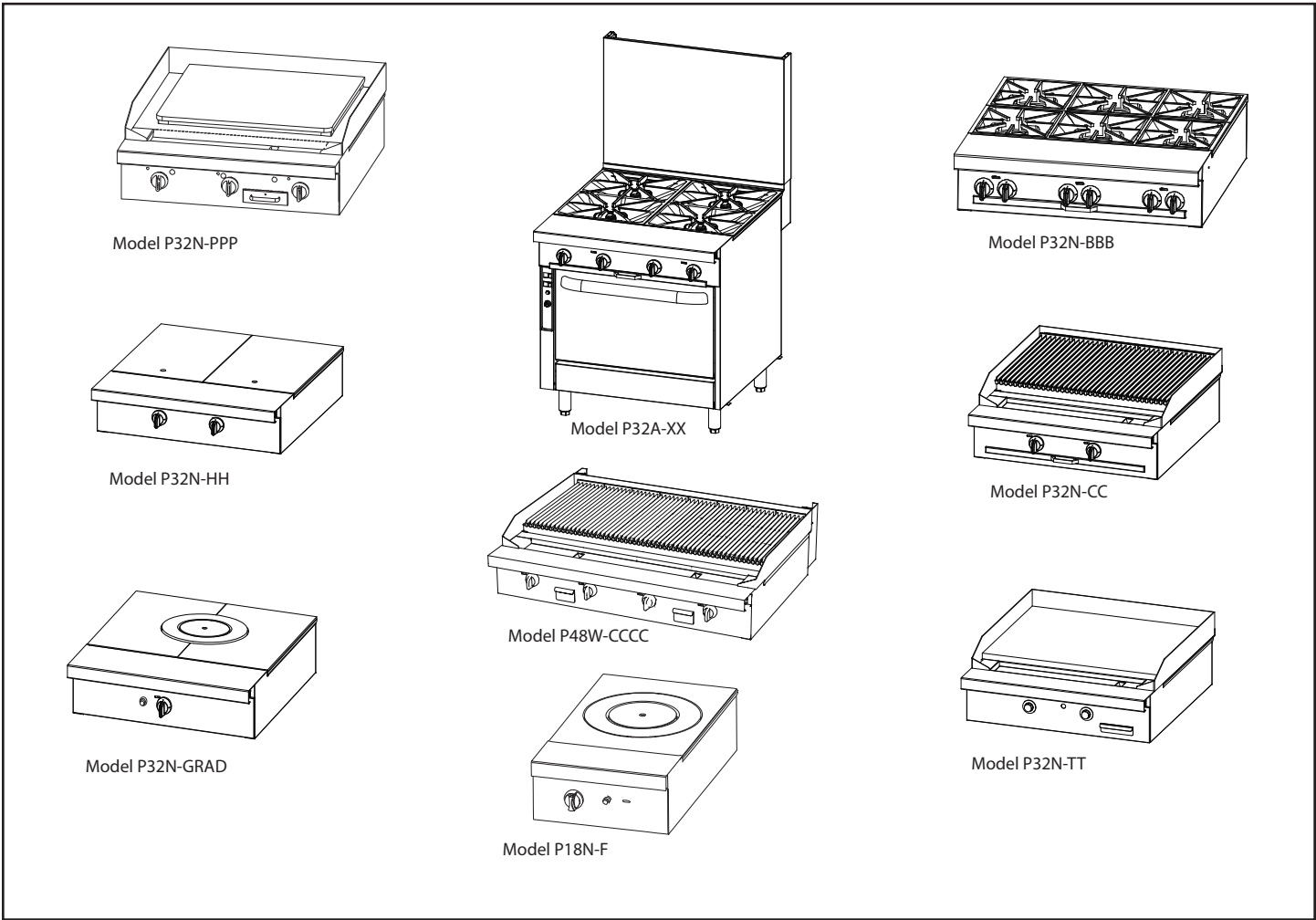

## ⚠ WARNING

Improper installation, adjustment, alteration, service, or maintenance can cause property damage, injury, or death. Read installation, operation, and maintenance instructions thoroughly before installing or servicing this equipment.

1100 Old Honeycutt Road Fuquay-Varina, North Carolina 27526 USA • [www.southbendnc.com](http://www.southbendnc.com)



# SAFETY PRECAUTIONS

Before installing and operating this equipment, be sure everyone involved in its operation is fully trained and aware of precautions. Accidents and problems can be caused by failure to follow fundamental rules and precautions.

The following symbols, found throughout this manual, alert you to potentially dangerous conditions to the operator, service personnel, or to the equipment.



This symbol warns of immediate hazards that will result in severe injury or death.



This symbol refers to a potential hazard or unsafe practice that could result in injury or death.



This symbol refers to a potential hazard or unsafe practice that could result in injury, product damage, or property damage.



This symbol refers to information that needs special attention or must be fully understood, even though not dangerous.

 **WARNING**  
**FIRE HAZARD**  
**FOR YOUR SAFETY**

Do not store or use gasoline or other flammable vapors and liquids in the vicinity of cooking appliances.

Keep area around cooking appliances free and clear of combustibles.

Purchaser of equipment must post in a prominent location detailed instructions to be followed in the event the operator smells gas. Obtain the instructions from the local gas supplier.

 **WARNING**  
**BURN HAZARD**

Contact with hot surfaces will cause severe burns. Always use caution when operating cooking appliances.

 **WARNING**  
**EXPLOSION AND ASPHYXIATION HAZARD**

In the event a gas odor is detected, shut down equipment at the main gas shut-off valve and immediately call the emergency phone number of your gas supplier.

Improper ventilation can result in headaches, drowsiness, nausea, and could result in death. Do not obstruct the flow of combustion and ventilation air to and from cooking appliances.

 **WARNING**  
**ELECTRIC SHOCK HAZARD**

For appliances that use electric power, disconnect the power to the appliance before cleaning. Do not remove panels that require tools to remove.

**NOTICE**

Southbend appliances are intended for commercial use only. Not for household use.

Warranty will be void if service work is performed by other than a qualified technician, or if other than genuine Southbend replacement parts are installed.

Give this Owner's Manual and important papers to the proper authority to retain for future reference.

# INTRODUCTION

Congratulations! You have purchased one of the finest pieces of heavy-duty commercial cooking equipment on the market.

You will find that your new equipment, like all Southbend equipment, has been designed and manufactured to meet the toughest standards in the industry. Each piece of Southbend equipment is carefully engineered and designs are verified through laboratory tests and field installations. With proper care and field maintenance, you will experience years of reliable, trouble-free operation. **For best results, read this manual carefully.**

RETAIN THIS MANUAL FOR FUTURE REFERENCE.

This manual is for Southbend Platinum Series Sectional Ranges.

This manual does NOT cover Southbend sectional fryers, fryer filter systems, salamander broilers, upright broilers, cheese melters, or refrigerated bases. Those appliances have their own manuals.

The location of the serial plate depends on the type of base (see Figure 1 below). On models with oven bases, the serial plate is located on the backside of the kick-plate below the oven door (lift the kick-plate straight up and tilt the top edge out and down.) On models with a cabinet base, the serial plate is located inside the left cabinet door. On modular (countertop) models, the serial plate is located inside the front valve panel.

Read these instructions carefully before attempting installation. Installation and initial startup should be performed by a qualified installer. Unless the installation instructions for this product are followed by a qualified service technician (a person experienced in and knowledgeable with the installation of commercial gas and/or electric cooking equipment) then the terms and conditions on the Manufacturer's Limited Warranty will be rendered void and no warranty of any kind shall apply.

In the event you have questions concerning the installation, use, care, or service of the product, contact:

Southbend Technical Service  
1100 Old Honeycutt Road  
Fuquay-Varina, North Carolina 27526 USA  
[www.southbendnc.com](http://www.southbendnc.com)

Figure 1

## Location of Serial Plate

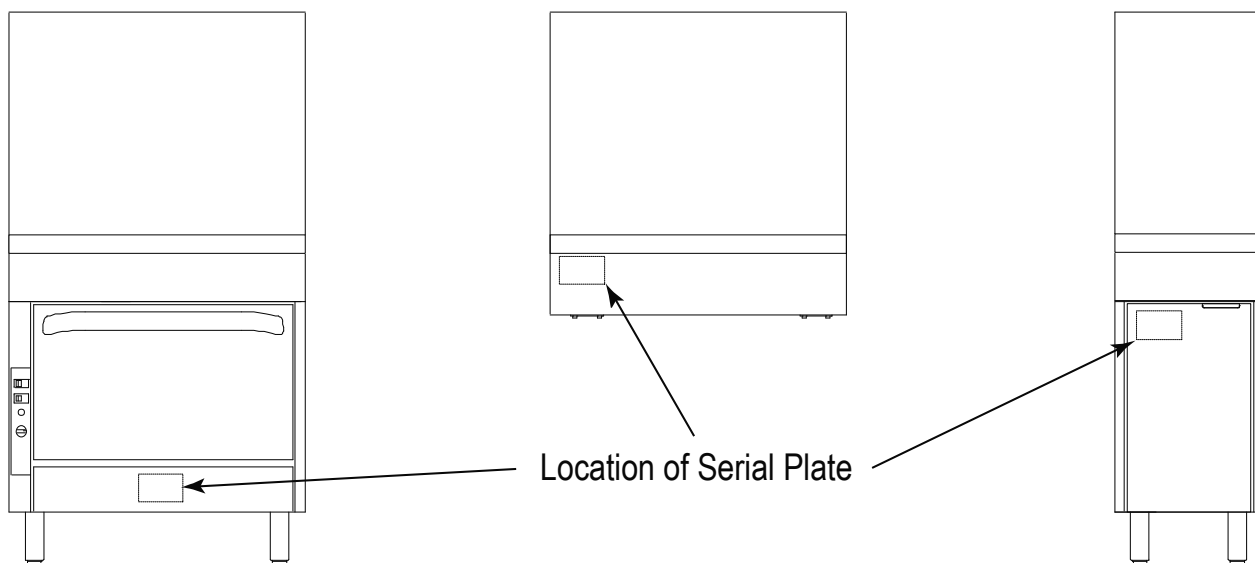

# SPECIFICATIONS

## NOTICE

Local codes regarding installation vary greatly from one area to another. The National Fire Protection Association, Inc., states in its NFPA 96 latest edition that local codes are the “authority having jurisdiction” when it comes to installation requirements for equipment. Therefore, installations should comply with all local codes.

Southbend reserves the right to change specifications and product design without notice. Such revisions do not entitle the buyer to corresponding changes, additions, or replacements for previously purchased equipment.

Southbend appliances are intended for commercial use only, not for household use.

The installation must conform with local codes, or in the absence of local codes, with the *National Fuel Gas Code, ANSI Z223.1, Natural Gas Installation Code, CAN/CGA-B149.1*, or the *Propane Installation Code CAN/CGA-B149.2*, as applicable, including:

1. The appliance and its individual shutoff valve must be disconnected from the gas supply piping system during any pressure testing of that system at test pressures in excess of 1/2 psi (3.45 kPa).
2. The appliance must be isolated from the gas supply piping system by closing its individual manual shutoff valve during any pressure testing of the gas supply piping system at test pressures equal to or less than 1/2 psi (3.45 kPa).

## CLEARANCES



### WARNING

#### MINIMUM CLEARANCES FROM COMBUSTIBLE CONSTRUCTION

There must be adequate clearance between the cooking equipment and combustible construction. Clearance must also be provided for servicing and for operation.

	Open-Top Standard-Burner Models	Open-Top PyroMax-Burner Models	Griddle Models	Uniform Hot-Top Models	Plancha Graduated Hot-Top Models
Sides	10"	13"	10"	10"	6"
Back	6"	6"	12"	12"	6"
Floor*	0"	0"	0"	0"	0"

**Do NOT install sectional charbroilers or wood smokers next to combustible materials.**

\* Models with 6" legs or casters are suitable for installation on combustible floors.

Adequate clearance must be provided in the aisle in front of the unit to permit operation (including opening of doors and/or removal of grease drawers, drippings trays, and/or oven racks), as well as for servicing. No additional clearance is required for servicing as the sectional range is serviceable from the front.

Models with a convection-type oven require a minimum clearance of 2" between the motor on the back and non-combustible construction. Care must be taken to provide adequate air circulation to prevent the motor from overheating.

Minimum clearance from noncombustible construction is zero on the sides and back for all models (except for models with a convection-type oven).

The high-temperature flue products flow out through the top of the flue riser of all models, and from the top of open-top and charbroiler models. Installation under a vented hood is recommended.

Salamander broilers and cheese melters mounted on the flue riser of a sectional range may require additional minimum clearances (see the documentation for those appliances).

## VENTILATION

### **WARNING**

Improper ventilation can result in personal injury or death. Ventilation which fails to properly remove flue products can cause headaches, drowsiness, nausea, or could result in death.

All gas appliances must be installed in such a manner that the flow of combustion and ventilation air is not obstructed. Provisions for adequate air supply must be provided. Do not obstruct the area under the control panel or below the oven door (on the front), or the area below the flue riser (on the back) as combustion air enters through these areas.

### **NOTICE**

Proper ventilation is the owner's responsibility. Any problem due to improper ventilation will not be covered by the warranty.

Be sure to inspect and clean the ventilation system according to the ventilation equipment manufacturer's instructions.

Air for combustion enters from the front below the valve panel, as well as from the rear into the burner box. Ranges with solid tops (griddles, planchas and hot-tops) vent their flue products up the flue riser. On units with a base oven, combustion air enters from the front below the oven door. Oven flue products are vented up the flue riser.

Lack of sufficient ventilation will cause poor burner and pilot operating characteristics, resulting in inefficient performance. Such conditions also cause high ambient temperatures at the manifold area and create valve and thermostat problems.

If a ventilation canopy is used, it is recommended that the canopy extend 6" past the sectional range and that the bottom edge be located 6'6" from the floor. Filters should be installed at an angle of 45° or more from the horizontal. This position prevents dripping grease, and facilitates collecting the run-off grease in a drip pan under the filter.

A strong exhaust fan tends to create a vacuum in the room and may interfere with burner performance or may extinguish pilot flames. Fresh air openings approximately equal to the fan area will relieve such a vacuum. The exhaust fan should be installed at least 2" above the top of the flue riser.

If the sectional range is connected directly to an outside flue, a CSA design certified down draft diverter must be installed.

In case of unsatisfactory performance by any gas appliance, check the appliance with the exhaust fan turned OFF. Do this only long enough to check whether doing so corrects any problems with equipment performance. Then turn the exhaust fan back on and let it run to remove any exhaust that may have accumulated during the test.

## GAS SUPPLY

The sectional range is design-certified for operation on natural or propane gases. The sectional range is shipped configured and adjusted for the type of gas specified by the purchaser, which is indicated on the serial plate (see Figure 1 on page 3). Connect the sectional range ONLY to the type of gas for which it is configured and adjusted.

Each section has a 1-1/4" front gas manifold that can be coupled to adjacent section(s). Sections can be ordered with an optional 1" rear gas connection with a male NPT connector. Minimum supply pressure is 7" W.C. for natural gas, 11" W.C. for propane. An external pressure regulator and shut off valve must be provided. If using a flexible-hose gas connection, the I.D. of the hose must not be smaller than the connector on the unit and must comply with ANSI Z21.69. Provide an adequate means of restraint to prevent undue strain on the gas connection.

If applicable, the vent line from the gas appliance pressure regulator shall be installed to the outdoors in accordance with local codes, or in the absence of local codes, with the *National Fuel Gas Code, ANSI Z223.1, Natural Gas Installation Code, CAN/CGA-B149.1, or the Propane Installation Code CAN/CGA-B149.2, as applicable.*

An adequate gas supply is imperative. Undersized or low pressure lines will restrict the volume of gas required for satisfactory performance. Fluctuations of more than 25% on natural gas or 10% on propane gas will create problems and affect burner operating characteristics. A 1/8" pressure tap is located on the manifold to measure the manifold pressure. The supply line to the sectional range should be no smaller than the inside diameter of the pipe on the sectional range to which it is connected.

## ELECTRICITY SUPPLY

Units with convection-oven bases with optional electronic ignition require electric power (50Hz or 60Hz single-phase AC). 120V models have a 7-foot (2134 mm) power cord with a grounded plug (1.0 amps for “D” Models and 4.8 amps for “A” Models). The 208/240V models have a terminal block for connection to a single-phase 208/240V source (1.0 amps for “D” Models and 2.6 amps for the “A” Models).

The appliance, when installed, must be electrically grounded in accordance with local codes, or in the absence of local codes, with the *National Electrical Code, ANSI/NFPA 70, or the Canadian Electrical Code, CSA C22.2*, as applicable. An electrical diagram is located on the rear of the range, near the motor.

# OPERATION

 **DANGER**  
**EXPLOSION HAZARD**

In the event a gas odor is detected, shut down equipment at the main shut off valve. Immediately call the emergency phone number of your gas supplier.

 **CAUTION**

If a pilot flame pilot should go out, the flow of gas to the corresponding burner is NOT interrupted. Consequently, it is the responsibility of the operator to check the ignition of each burner immediately EVERY TIME a burner is turned on. Should ignition fail after 10 seconds, turn off the burner, wait 5 minutes, and then try again.

## LIGHTING AFTER GAS HAS BEEN SHUT OFF

When turning on the main gas supply to a sectional range, do the following:

1. Make sure that all the control knobs and power switches of all the connected appliances are in the OFF position.
2. Turn on the gas-supply shut-off valve(s).
3. Light the standing pilots of each connected appliance.
4. Light the ovens of the sectional range first, then wait six minutes before turning on the top sections.

This enables all air to be purged from the sectional-range gas piping.

## SHUTDOWN OF ENTIRE RANGE

To place the range in a standby state (ready for use), Oven bases with the electronic ignition option, turn all burner control knobs to OFF, set all thermostats to their lowest position, and switch all ovens OFF. The pilots will remain lit. On the standing pilot units, same as above except turn thermostat knob to the "OFF" position. The pilots will remain lit.

To completely shut down the range for an extended period (or prior to disconnecting the gas supply), place the range in a standby state (as described in the previous paragraph), then turn OFF the manual shut-off valves of all gas supply connections. This will extinguish the pilots.

Figure 2

## Operation of Open-Burner Sections

Each knob can be turned to OFF or to any position in the range from LOW to HIGH. The left knob controls the rear burner, while the right knob controls the front burner. Each knob can be turned to OFF or to any position in the range from LOW to HIGH.

To start cooking, turn the appropriate control knob to HIGH. Visually check that the burner ignites. **The gas does NOT automatically shut off if the burner does not ignite!** If the burner does not ignite, check and/or light the pilots (see procedure at right). When the burner is hot, the burner flame should appear blue and steady (some slight yellowing of the flame tips may occur when using propane gas).

While cooking, do not allow excessive drippings and/or debris to accumulate on or below the burners. When necessary, pull out and clean the drippings tray.

When done cooking, turn the appropriate control knob to OFF. (The pilot should remain lit).

Each burner has a pilot located beside the burner. To light a pilot, do the following:

1. Check that the burner control knob is in the OFF position.
2. Check that the pilot is in the correct position beside the burner.
3. Turn on the gas supply to the sectional range (if not already on).
4. Light the pilot with a match or a pilot-lighting device. The pilot flame should be blue and steady.

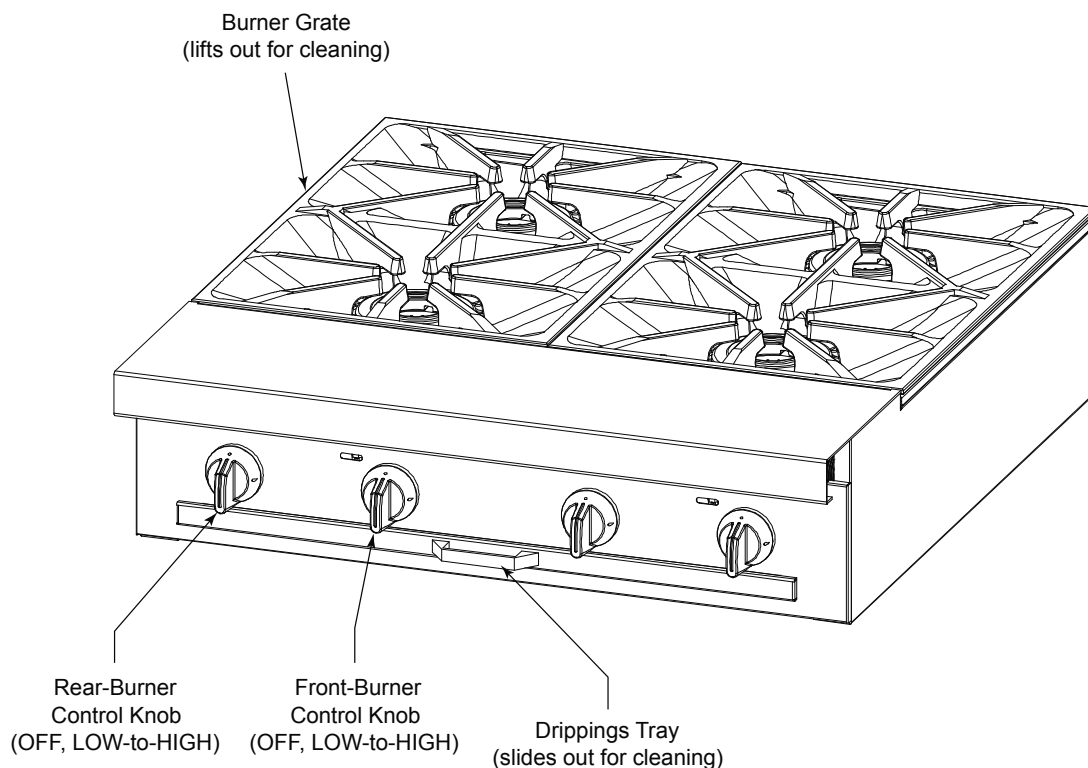



Figure 3

### Operation of Uniform Hot-Top Section

Each control knob can be turned to OFF or to any position in the range from LOW to HIGH. When the control is set to HIGH, the hot top surface will heat to about 700°F (370°C).

To start cooking, turn the appropriate control knob to HIGH. Visually check that the burner ignites. **The gas does NOT automatically shut off if the burner does not ignite!** If the burner does not ignite, check and/or light the pilots (see procedure at right). When the burner is hot, the burner flame should appear blue and steady (some slight yellowing of the flame tips may occur when using propane gas).

**Do not waste gas and abuse equipment by leaving the burner on HIGH all the time.** Damage to the plates and certain electronic components may occur, and **MAY VOID YOUR WARRANTY.** During idle periods, turn the control to LOW to keep the top warm.

When done cooking, turn the appropriate control knob to OFF. (The pilot should remain lit).

Each burner has a pilot located near the front of the burner. To light the pilots, do the following:

1. Check that the control knob is in the OFF position.
2. Turn on the gas supply to the sectional range (if not already on).
3. Lift up a hot-top section plate.
4. Verify pilots are lit. If spark ignition system is faulty, light pilot manually with a match or pilot lighting device.
5. Push spark ignition button for approximately 10 seconds.
6. Replace hot-top section before use.

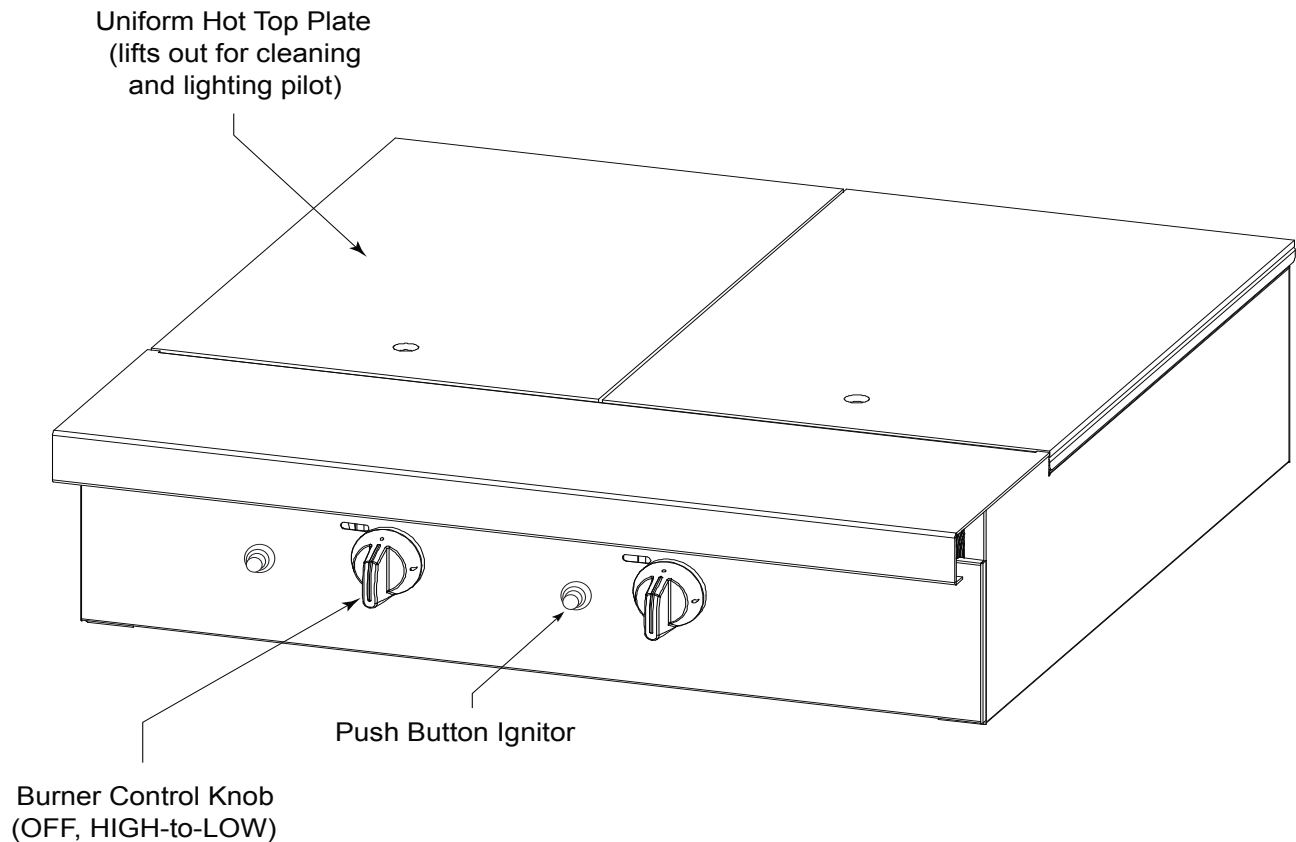

Figure 4

## Operation of Graduated Hot-Top Section

Each control knob can be turned to OFF or to any position in the range from LOW to HIGH. When the control is set to HIGH, the round center section will heat to about 725°F (385°C), the ring-shaped section will heat to about 625°F (330°C), and the outer areas will heat to about 500°F (260°C).

To start cooking, turn the control knob to HIGH. Visually check that the burner ignites. **The gas does NOT automatically shut off if the burner does not ignite!** If the burner does not ignite, check and/or light the pilots (see procedure at right). When the burner is hot, the burner flame should appear blue and steady (some slight yellowing of the flame tips may occur when using propane gas).

**Do not waste gas and abuse equipment by leaving the burner on HIGH all the time.** Damage to the plates and certain electronic components may occur, and **MAY VOID YOUR WARRANTY.**

When done cooking, turn the control knob to OFF. (The pilot should remain lit).

Each 32", 36"-wide section has one burner. The pilot is located adjacent to the burner. To light the pilot, do the following:

1. Check that the control knob is in the OFF position.
2. Turn on the gas supply to the sectional range (if not already on).
3. Remove round center plate.
4. Push spark ignition button for approximately 10 seconds.
5. Verify pilots are lit. If spark ignition system is faulty, light pilot manually with a match or pilot lighting device.
6. Replace round center plate before use.

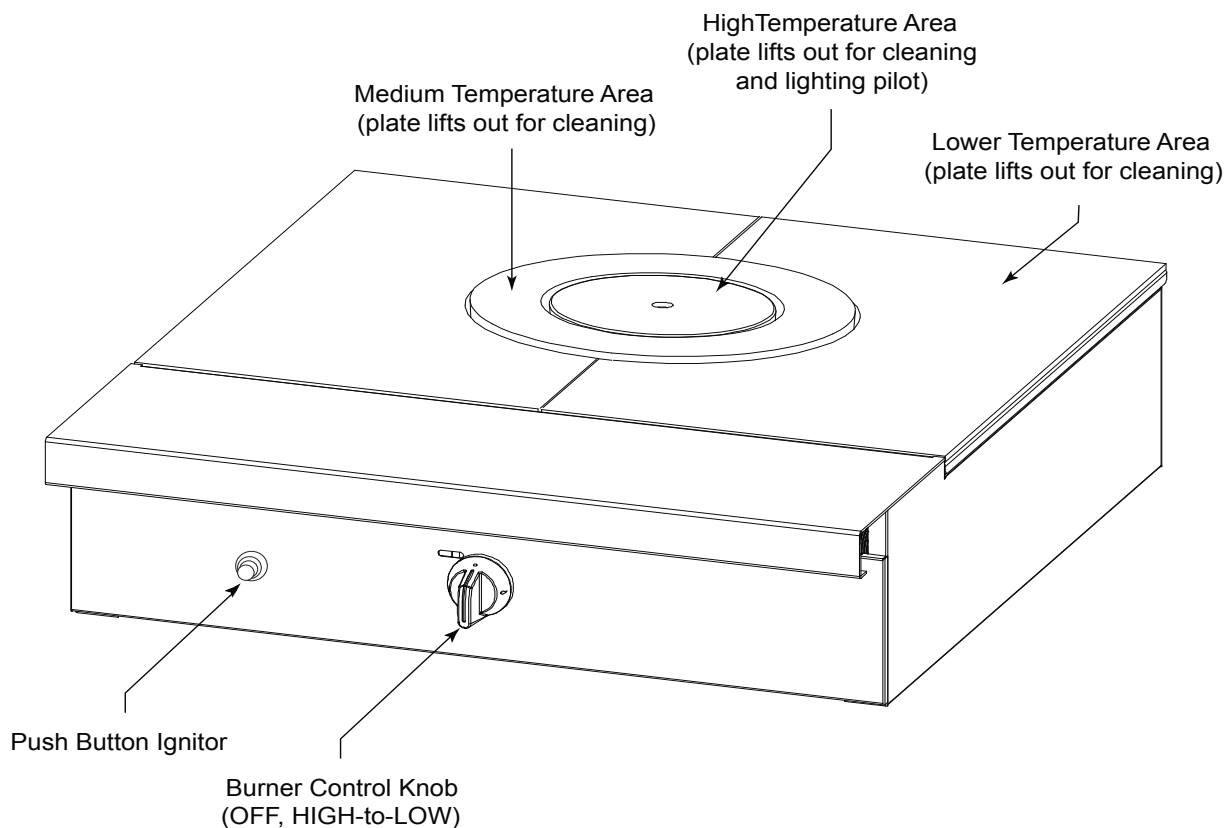

Figure 5

## Operation of French Hot-Top Section

Each control knob can be turned to OFF or to any position in the range from LOW to HIGH. When the control is set to HIGH, the round center section will heat to about 900°F (482°C), the ring-shaped section will heat to about 800°F (427°C), and the outer areas will heat to about 600°F (316°C).

To start cooking, turn the control knob to HIGH. Visually check that the burner ignites. **The gas does NOT automatically shut off if the burner does not ignite!** If the burner does not ignite, check and/or light the pilots (see procedure at right). When the burner is hot, the burner flame should appear blue and steady (some slight yellowing of the flame tips may occur when using propane gas).

**Do not waste gas and abuse equipment by leaving the burner on HIGH all the time.** Damage to the plates and certain electronic components may occur, and **MAY VOID YOUR WARRANTY.**

When done cooking, turn the control knob to OFF. (The pilot should remain lit).

Each 18"-wide section has one burner. The pilot is located adjacent to the burner. To light the pilot, do the following:

1. Check that the control knob is in the OFF position.
2. Turn on the gas supply to the sectional range (if not already on).
3. Remove round center plate.
4. Push spark ignition button for approximately 10 seconds.
5. Verify pilots are lit. If spark ignition system is faulty, light pilot manually with a match or pilot lighting device.
6. Replace round center plate before use.

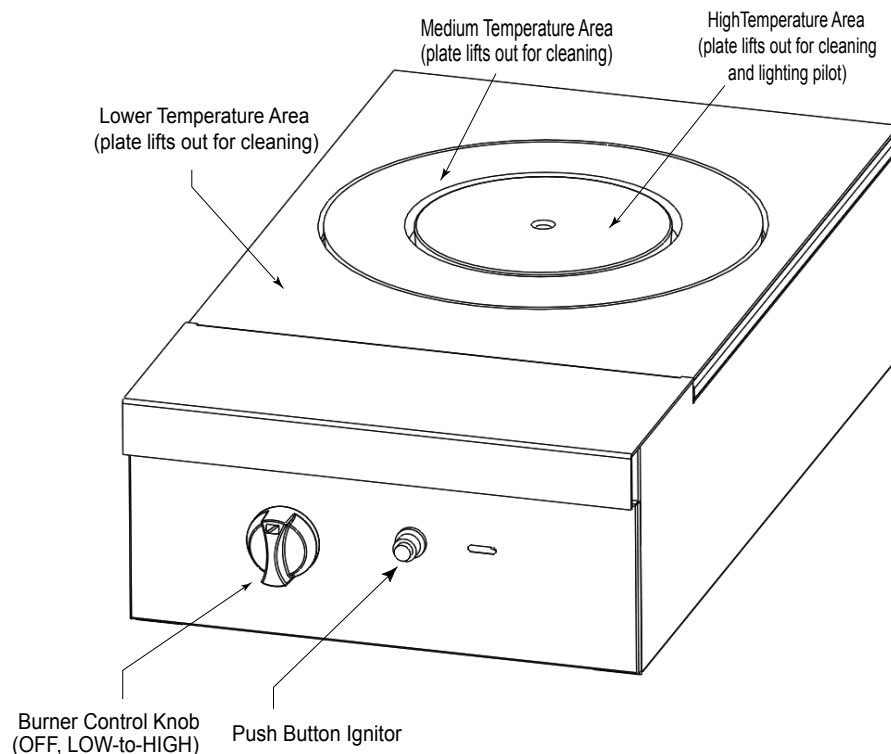

Figure 6

## Operation of Charbroiler Section

Each control knob can be turned to OFF, or to any position in the range from LOW-to-HIGH. Each 6"-wide burner top-grate can be turned over to provide either wide branding marks or narrower branding marks with channels to carry away drippings (and so reduce flare up). The back-to-front slope of each top-grate is adjusted by positioning the back end of the top-grate on either the lower or the higher grate-support rail. The radiants (just above the burners) can be reversed front-and-back to provide higher heat toward the back than the front, or vice versa. "Lava rock" briquettes can be placed on grates located above the radiants.

To start cooking, turn the appropriate control knob to HIGH. Visually check that the burner ignites. **The gas does NOT automatically shut off if the burner does not ignite!** If the burner does not ignite, check and/or light the pilots (see procedure at right). When the burner is hot, the burner flame should appear blue and steady (some slight yellowing of the flame tips may occur when using propane gas).

When done cooking, turn the appropriate control knob to OFF. (The pilot should remain lit).

Each burner has a pilot located near the front. To light the pilots, do the following:

1. Check that the burner control knob is in the OFF position.
2. Lift up a grate in order to expose the two pilots.
3. Check that each pilot is in the correct position.
4. Turn on the gas supply to the sectional range (if not already on)
5. Light the pilots with a match or a pilot-lighting device. The pilot flames should be blue and steady.

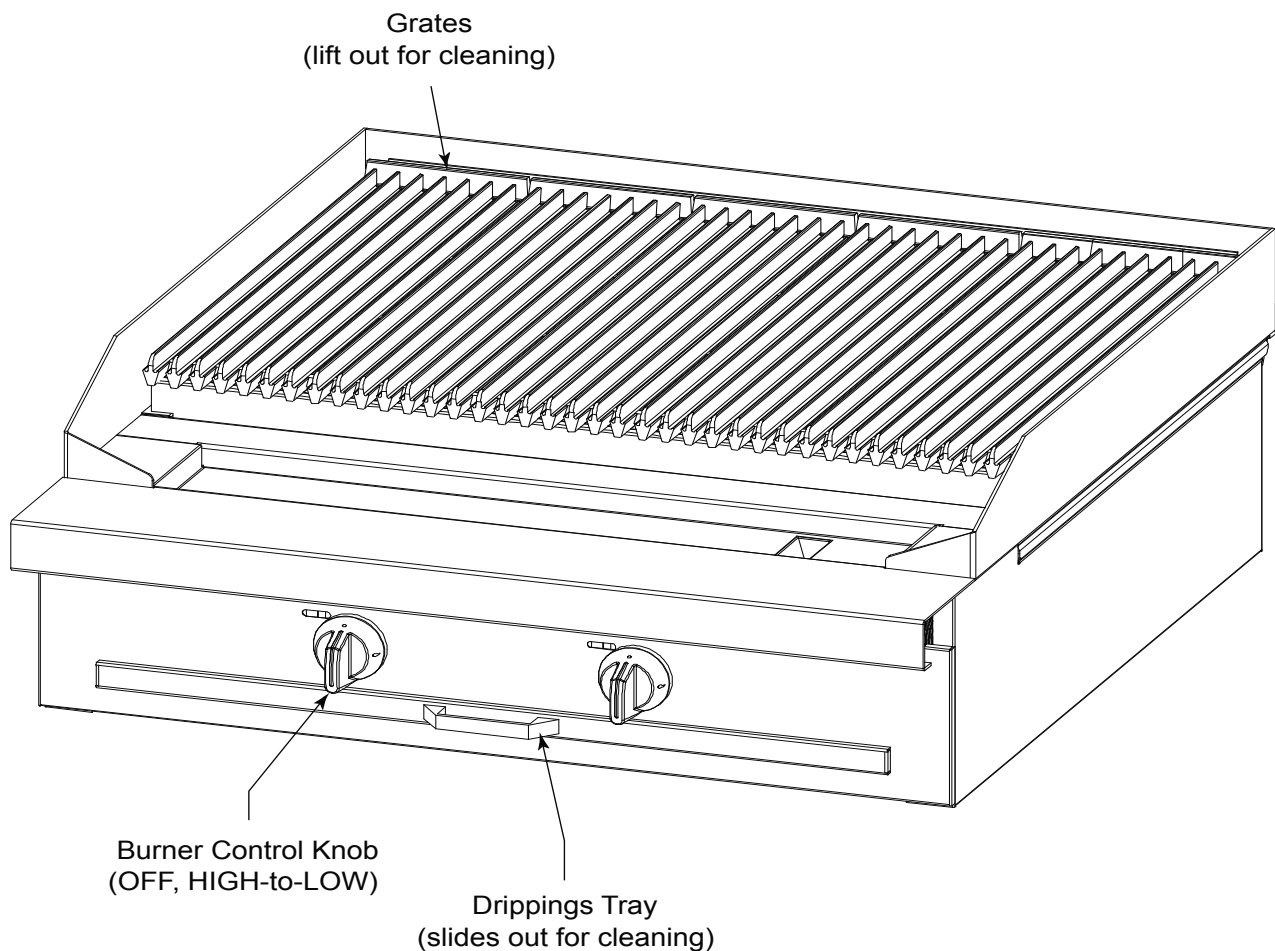

Figure 7

## Operation of Wood Smoker Section

Each control knob can be turned to OFF, or to any position in the range from LOW to HIGH. Each 6"-wide burner top-grate can be turned over to provide either wide branding marks or narrower branding marks with channels to carry away drippings (and so reduce flare up). The back-to-front slope of each top-grate is adjusted by positioning the back end of the top-grate on either the lower or the higher grate-support rail. The radiants (just above the burners) can be reversed front-and-back to provide higher heat toward the back than the front, or vice versa.

To start cooking, turn the appropriate control knob to HIGH. Visually check that the burner ignites. **The gas does NOT automatically shut off if the burner does not ignite!** If the burner does not ignite, check and/or light the pilots (see procedure at right). When the burner is hot, the burner flame should appear blue and steady (some slight yellowing of the flame tips may occur when using propane gas).

The smoker can use either split or chunk wood. (Chunk wood can be ordered from Southbend; Hickory Chunks, 10 lb bag, Southbend P/N 1188495; or Mesquite Chunks, 10 lb bag Southbend P/N 1188496.) Split wood pieces can be up to 4" diameter and 20" long.

Wood life can be extended by pre-soaking the wood in water for a couple of hours prior to use. Do not soak the wood overnight as it will become too saturated and delay ignition.

**WARNING / CAUTION:** Never use treated wood. When burned, treated wood can release pollutants harmful to your health into the air.

Each burner has a pilot located near the front. To light the pilots, do the following:

1. Check that the burner control knob is in the OFF position.
2. Lift up a grate in order to expose the two pilots.
3. Check that each pilot is in the correct position.
4. Turn on the gas supply to the sectional range (if not already on).
5. Light the pilots with a match or a pilot-lighting device. The pilot flames should be blue and steady.

### To start cooking, do the following:

1. Fill Water/Catch Tray with water to bottom of wood grate.
2. Open the Smoker Box Door and place an even layer of selected wood on the grate inside the smoker box. The Smoker Box Door should be kept closed during normal operation.
3. Turn control knobs to HIGH position. Visually check that the burner ignites. The wood will then ignite. (Ignition time for wood in the smoker will vary due to moisture content and type of wood used.)
4. Once the wood ignites, adjust the control knobs to the desired setting for cooking.

When done cooking, do the following:

1. Turn the control knobs to OFF. (The pilots should remain lit).
2. Extinguish all remaining embers, or allow all wood to burnout.
3. Place all remaining wood in a fire-safe container.
4. Remove and clean wood grate.
5. Remove Water/Catch Tray and dispose of its content in a fire-safe container.

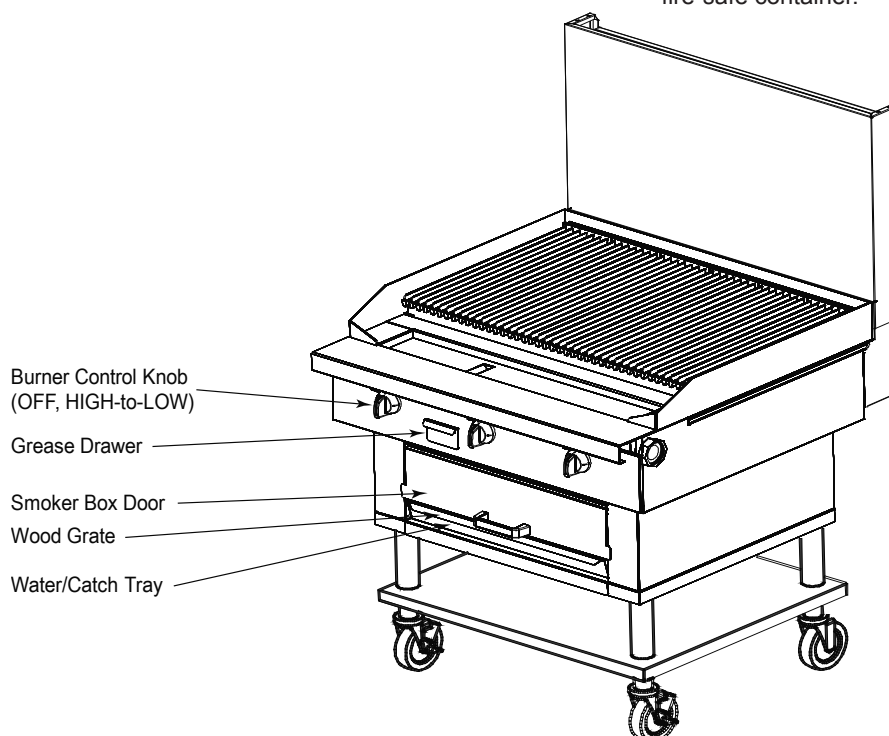

Figure 8

## Operation of Plancha Griddle Sections

Each control knob can be turned to OFF or to any position in the range from low to high.

To start cooking, turn the control knob to HIGH. Check that the burner ignites. **The gas does NOT automatically shut off if the burner does not ignite!** If the burner does not ignite, check and/or light the pilots (see procedure at right). When the burner is hot, the burner flame should appear blue and steady (some slight yellowing of the flame tips may occur when using propane gas).

Always remember to heat the Plancha slowly because quick heating may cause costly damage. Never place utensils on the griddle.

**Do not waste gas and abuse equipment by leaving the Plancha on HIGH all the time.** Damage to the Placha and certain electronic components may occur, and **MAY VOID YOUR WARRANTY.**

When necessary while cooking, pull out and empty the grease drawer.

When done cooking, turn the appropriate control knob to OFF. (The pilot should remain lit).

Each burner has a pilot that is lit using the spark igniter push button, (if equipped) or a long match inserted through a hole in the front valve panel. (A 32"-wide Plancha has three pilots.) To light the pilot, do the following:

1. Check that all the control knobs are in the OFF position.
2. Turn on the gas supply to the sectional range (if not already on).
3. Push spark ignition button for approximately 10 seconds.
4. Verify pilots are lit by looking through site holes in valve panel. If spark ignition system is faulty, light pilots manually.
5. Pilots are lit manually by inserting a long match (at least 11" long) or pilot-lighting device straight into the hole on the front valve panel for each burner of the Plancha.

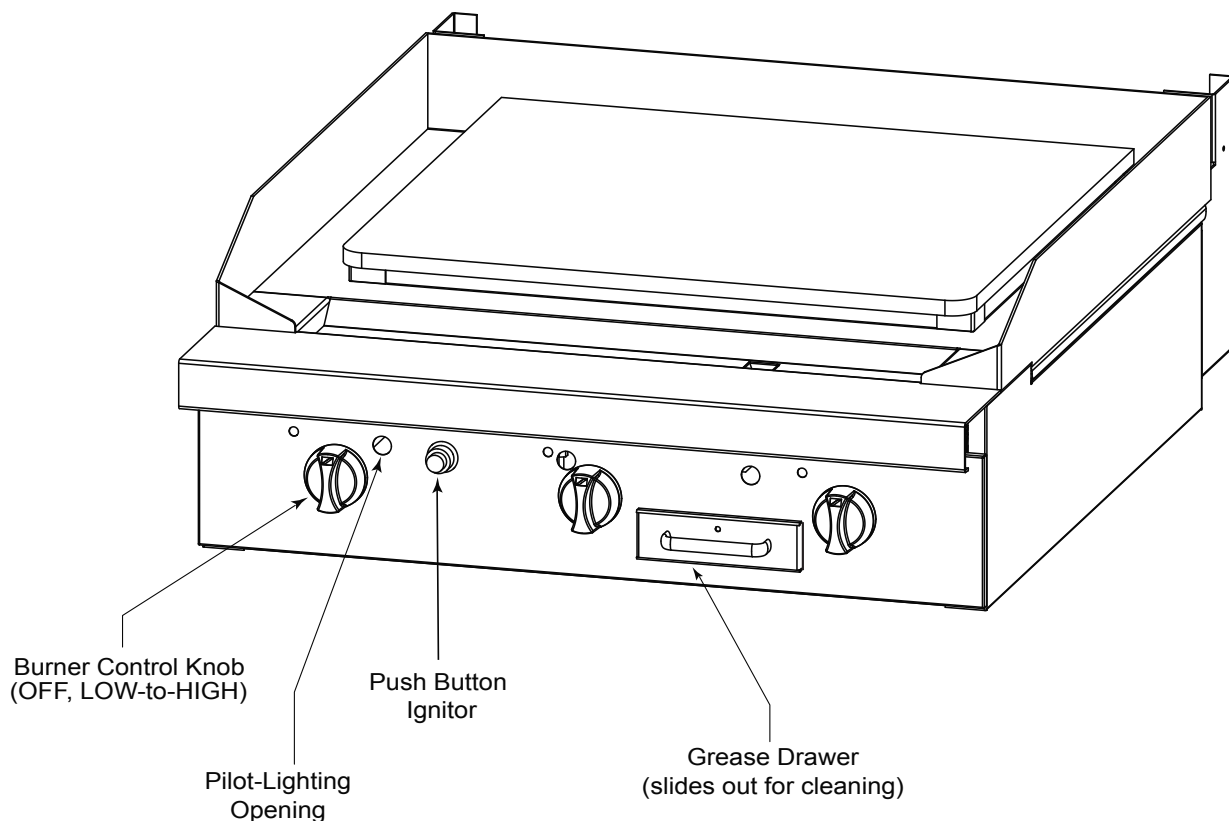

Figure 9

## Operation of Standard (Non-Thermostatic) Griddle Sections

Each control knob can be turned to OFF, or any position in the range from LOW-to-HIGH.

To start cooking, turn the control knob to HIGH. Check that the burner ignites. **The gas does NOT automatically shut off if the burner does not ignite!** If the burner does not ignite, check and/or light the pilots (see procedure at right). When the burner is hot, the burner flame should appear blue and steady (some slight yellowing of the flame tips may occur when using propane gas).

Always remember to heat the griddle slowly because quick heating may cause costly damage. Never place utensils on the griddle.

**Do not waste gas and abuse equipment by leaving the griddle on HIGH all the time.** Damage to the griddle and certain electronic components may occur, and **MAY VOID YOUR WARRANTY.** During idle periods, turn the control to LOW to keep the griddle warm. (Do not allow the griddle to overheat above 550°F (288°C), as this will cause warping or breakage.)

When necessary while cooking, pull out and empty the grease drawer.

When done cooking, turn the appropriate control knob to OFF. (The pilot should remain lit).

Each griddle section up to 36" wide, has a single pilot that is lit using a spark ignitor push button (if equipped) or a long match inserted through a hole in the front valve panel. (A 48"-wide griddle has two pilots.) To light the pilot, do the following:

1. Check that all the control knobs are in the OFF position.
2. Turn on the gas supply to the sectional range (if not already on).
3. Push spark ignition button for approximately 10 seconds.
4. Verify pilot is lit by looking through site hole in valve panel. If spark ignition system is faulty, light pilots manually.
5. Pilots are lit manually by inserting a long match (at least 11" long) or pilot-lighting device straight into the hole on the front valve panel of the griddle.

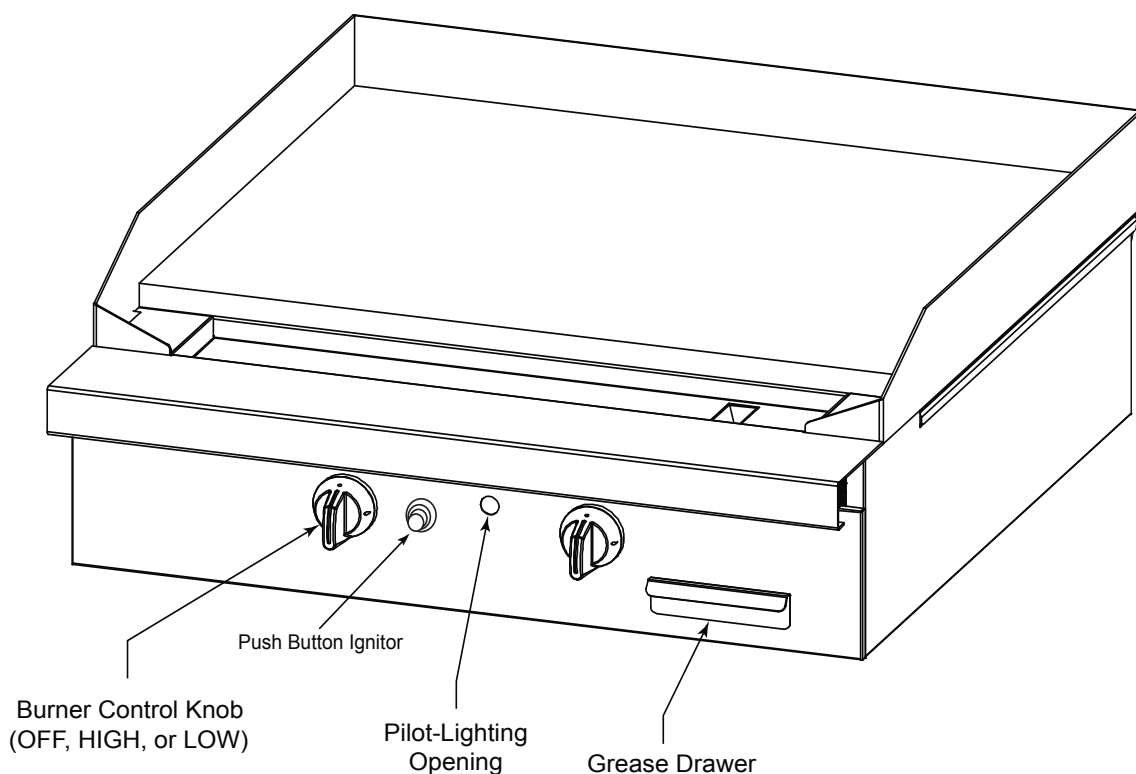

Figure 10

## Operation of Thermostatic Griddle Sections

Each control knob that can be turned to OFF, or to any temperature in the range 150°F to 400°F (66°C to 204°C).

To start cooking, turn on the appropriate control knob. Check that the burner ignites. If the burner does not ignite, check and/or light the pilots (see procedure at right).

Never place utensils on the griddle.

Do not waste gas and abuse equipment by leaving the griddle set at a high temperature all the time. Damage to the griddle and certain electronic components may occur, and **MAY VOID YOUR WARRANTY**. During idle periods, turn the control to a low temperature to keep the griddle warm. (Do not allow the griddle to overheat above 550°F (288°C), as this will cause warping or breakage.)

When necessary while cooking, pull out and empty the grease drawer.

When done cooking, turn the appropriate control knob to OFF. (The pilot should remain lit).

Each griddle section up to 36" wide has a single pilot that is lit using a long match inserted through a hole in the front valve panel. (A 48"-wide griddle has two pilots.) To light the pilot, do the following:

1. Check that all control knobs are in the OFF position.
2. Turn on the gas supply to the sectional range (if not already on).
3. Press and hold in the Safety Switch Button.
4. Push spark ignition button for approximately 10 seconds.
5. Verify pilots are lit by looking through site hole in valve panel. If spark ignition system is faulty, light pilots manually.
6. Pilots are lit manually by inserting a long match (at least 11" long) or pilot-lighting device straight into the hole on the front valve panel of the griddle.
7. After about a minute, release the Safety Switch Button. The pilot should remain lit.

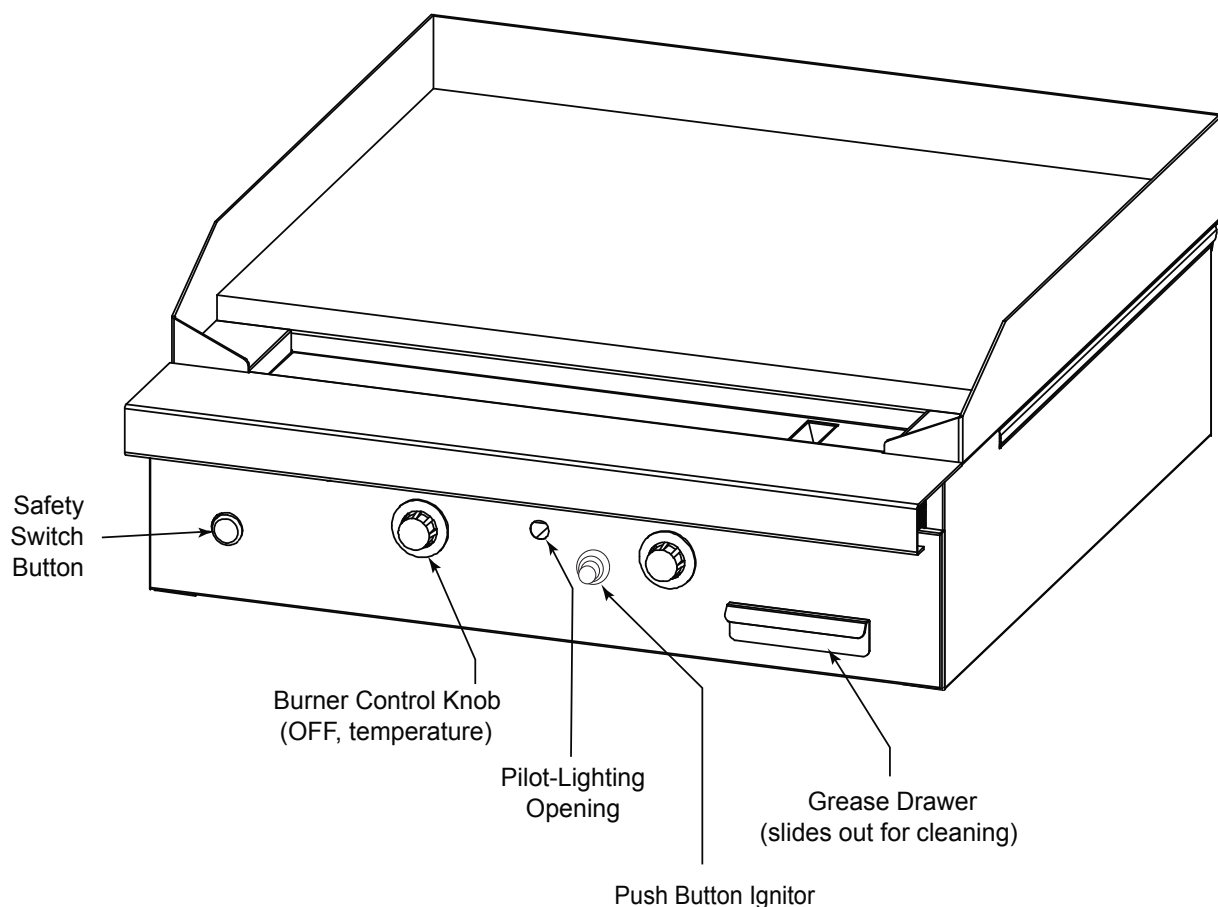



Figure 11

### Operation of Oven

Each oven has a thermostatic control that can be set in the range 175°F to 550°F (66°C to 260°C). Convection ovens have a fan that can be set to HI speed or LO speed.

For advice on using a convection oven, see the information on the following two pages of this manual.

While cooking, if the door is opened on a convection oven, the fan and heat will temporarily stop until the door is closed.

Do not allow excessive drippings and/or debris to accumulate on the interior of the oven. When necessary, pull out and clean the oven-bottom tray.

To light and start cooking, do the following:

#### FOR UNITS WITH A STANDING PILOT

1. Open kick panel and locate knob on valve assembly.
2. Turn the knob to PILOT and press inward. While holding the knob inward, light the pilot with an appropriate lighter.
3. Hold knob in the inward position for 30 seconds and release. The pilot should remain lit.
4. Turn the knob to ON and close kick panel.
5. Select on the thermostat the cooking temperature appropriate for the food to be cooked.
6. For convection ovens, select the fan speed appropriate for the food to be cooked.

#### FOR UNITS WITH ELECTRONIC IGNITION

1. Turn the Oven Gas Shut-Off Valve to ON.
2. Set the Oven Power Switch to ON. The pilot will light automatically (You will hear a “snapping” sound until the pilot ignites.)
3. Select on the thermostat the cooking temperature appropriate for the food to be cooked.
4. For convection ovens, select the fan speed appropriate for the food to be cooked.
5. On units with a cooking light, the light will go out when the oven reaches the set temperature.

When done cooking, turn the Oven Power Switch to OFF and turn the Oven Gas Shut-Off Valve to OFF.

#### Controls for Ovens with Standing Pilot

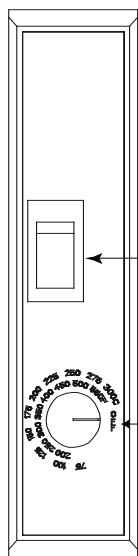

#### Controls for Ovens with Electronic Ignition

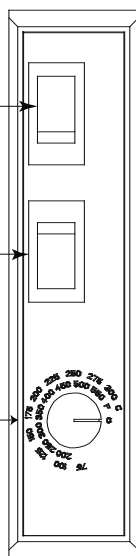

Oven Power Switch

Fan-Speed Switch (for Convection Ovens)

Oven Thermostat

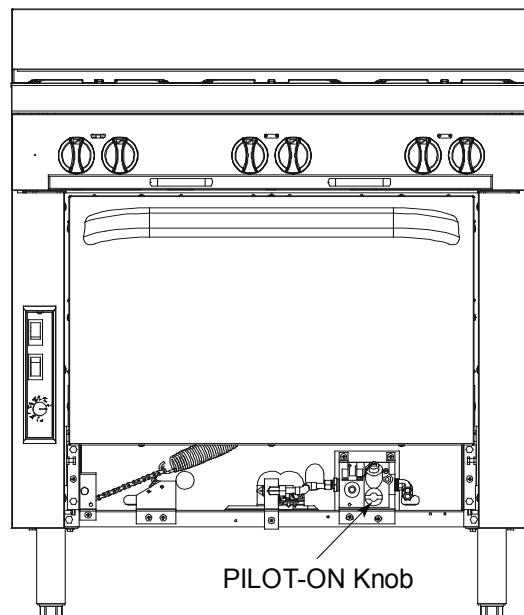

### WARNING

THE USE OF ALUMINUM FOIL CAN CAUSE HEAT DISTRIBUTION PROBLEMS IN OVENS. EXTREME CARE MUST BE USED WHEN PLACING ALUMINUM FOIL IN THE OVEN TO ENSURE THAT IT DOES NOT BLOCK OR CHANGE THE AIR FLOW. THE USE OF ALUMINUM FOIL MAY VOID THE PRODUCT WARRANTY IF ITS USE IS ASCERTAINED TO BE A PROBLEM.

## SUGGESTIONS FOR COOKING USING A CONVECTION OVEN

As a guide, set oven temperatures 25 to 50 degrees lower than called for in recipes using conventional (non-convection) ovens.

**FROZEN ENTREE PRODUCTS:** Punch holes in lid before heating. Tent lid if product has a tendency to stick, i.e., lasagna or macaroni and cheese. Use manufacturer’s convection oven directions for time and temperature or reduce conventional oven temperature 50 degrees for a 6-1/2 size pan load. Some products may cook in 10 to 15 minutes less time than recommended for convection ovens if prepared from frozen in a 6 pan load.

Time and temperatures will vary depending upon load, mix, size of portion, and other factors. Use the following chart to develop your own cooking techniques:

Product	Timing (minutes)	Temperature Setting	Number of Racks Used	Count per Pan/Rack
Hamburger buns, 3 oz. - 4"	18	375°	3	24
Yeast rolls - 1 oz. Use temperature and time recommended by manufacturer for convection ovens for a 3 pan load.	10	400°	3	48
Fruit pies, 46 oz. frozen Use temperature and time from manufacturer's directions for convection ovens for a 12 pie load placed on 3 bun pans.	50	375°	3	4
Egg custard pies, 44 oz. frozen	60	325°	3	4
Dutch apple pies, 46 oz. frozen	50	350°	3	4
Baked potatoes, 8 oz. Wash and wrap in potato foil. Place 30 potatoes on 18 x 24 bun pan — 3 pans per load. Bake in 400°F oven for 1 hour.	60	400°	3	30 (wrapped)
Pre-blanched potatoes, frozen Spread on ungreased bun pans, 3 pans per load. Bake at 400°F, stirring once, for 15 to 18 minutes	16	400°	3	5lb.
Fish portions, pre-cooked, breaded, 3 oz. Use manufacturer’s recommended temperature and time for convection oven for a 3 pan load.	16	400°	3	32
Macaroni & cheese, 6 lbs. - 40° temp.	45	400°	3	2-6lbs.
Lasagna w/meat sauce, 6 lb. - 40° temp.	60	350°	3	2-6lbs.
Lasagna w/meat sauce, 6 lb. - frozen	75	350°	3	2-6lbs.
Salisbury steak w/gravy, 6 lb. - 40° temp.	45	400°	3	2-6lbs.
Top round of beef No. 168				
14 lb. - rare	140° internal 14 min./lbs.	250°	1	1-2
14 lb. - medium	150° internal 14 min./lbs.	250°	1	1-2
14 lb. - well done	160° internal 14 min./lbs.	250°	1	1-2

## CORRECTING PROBLEMS WHEN COOKING WITH A CONVENTION OVEN

<b>If...</b>	<b>Then...</b>
Cakes are dark on the sides and not done in the center...	lower oven temperature
Cake edges are too brown...	reduce number of pans or lower oven temperature
Cakes have light outer color...	raise temperature
Cake settles slightly in the center...	bake longer or raise oven temperature slightly. Do not open doors too often for long periods.
Pies have uneven color...	reduce number of pies per rack.
Meats are browned, but not done in center...	lower oven temperature and roast longer
Meats are well done and not browned...	raise temperature. Limit amount of moisture
Cakes ripple...	pans are overloaded or batter is too thin
There is excessive meat shrinkage...	lower oven temperature.
Cakes are too coarse...	lower oven temperature

# CLEANING & MAINTENANCE

## WARNING

Disconnect the power supply to the appliance before cleaning. Do not remove panels that require tools to remove.

## WARNING

Adjustments and service work should be performed only by a qualified technician who is experienced in, and knowledgeable with the operation of commercial gas cooking equipment. To assure confidence, contact your authorized service agency for reliable service, advice and other assistance with your appliance. Insist upon genuine factory parts to be used for any repair or service of your appliance.

Southbend appliances are sturdily constructed of the best materials and are designed to provide durable service when treated with ordinary care. To expect the best performance, your equipment must be maintained in good condition and cleaned daily. Naturally, the periods for this care and cleaning depend on the amount and degree of usage.

*Following daily and periodic maintenance procedures will enhance long life for your equipment. Climatic conditions (such as salt air) may require more thorough and frequent cleaning or the life of the equipment could be adversely affected.*

Keep exposed, cleanable areas clean at all times.

## DAILY CLEANING AND MAINTENANCE

The daily cleaning procedure is as follows:

1. Shut off the main gas supply and allow the sectional range to cool.
2. Pull out, empty, and clean all drippings trays and grease drawers.
3. Remove and clean all oven racks and oven-bottom trays. Wipe clean the interior of the oven.
4. Visually check for any food and/or debris that may have fallen down into the burner areas.
5. Wipe clean all exterior surfaces.
6. Replace the cleaned and dried drippings trays, grease drawers, and oven components.
7. Check that nothing has been left on or near the sectional range that might block the entry of combustion air or the escape of combustion exhaust.

## MONTHLY CLEANING AND MAINTENANCE

The following tasks should be performed monthly:

1. Clean around burners air mixers and orifices if debris has accumulated in these areas.
2. Check for proper pilot operation. Check that the pilot flames are blue (with little or no yellow in the flame tips), stable (not lifting off the pilots), and not producing carbon. If adjustment is necessary, call for service.
3. Check for proper burner operation. The burner flames should be blue and stable. If adjustment is necessary, call for service. the escape of combustion exhaust.

## SEMIANNUAL CLEANING AND MAINTENANCE

At least twice a year the venting system should be examined and cleaned.

## STAINLESS-STEEL SURFACES

To remove normal dirt, grease and product residue from stainless steel surfaces that operate at LOW temperature, use ordinary soap and water (with or without detergent) applied with a sponge or cloth. Dry thoroughly with a clean cloth.

To remove BAKED-ON grease and food splatter, or condensed vapors; apply cleanser to a damp cloth or sponge and rub cleanser on the metal in the direction of the polishing lines on the metal. Rubbing cleanser, as gently as possible, in the direction of the polished lines will not mar the finish of the stainless steel. NEVER RUB WITH A CIRCULAR MOTION. Soil and burnt deposits which do not respond to the above procedure can usually be removed by rubbing the surface with SCOTCH-BRITE scouring pads or STAINLESS scouring pads. DO NOT USE ORDINARY STEEL

WOOL as any particles left on the surface will rust and further spoil the appearance of the finish. NEVER USE A WIRE BRUSH, STEEL SCOURING PADS (EXCEPT STAINLESS), SCRAPER, FILE OR OTHER STEEL TOOLS. Surfaces which are marred collect dirt more rapidly and become more difficult to clean. Marring also increases the possibility of corrosive attack. Refinishing may then be required.

“Heat tint” is darkened areas that sometimes appear on stainless steel surfaces where the area has been subjected to excessive heat. These darkened areas are caused by thickening of the protective surface of the stainless steel and are not harmful. Heat tint can normally be removed by the foregoing, but tint which does not respond to this procedure calls for a vigorous scouring in the direction of the polish lines using SCOTCH-BRITE scouring pads or a STAINLESS scouring pad in combination with a powered cleanser. Heat tint may be lessened by reducing heat to equipment during slack periods.

## BLACK BAKED-ENAMEL SURFACES

Allow appliance to cool somewhat after use and wash black baked-enamel surfaces with a hot, mild detergent or soap solution. In particular, clean off all grease deposits. Dry thoroughly with a dry cloth.

## OPEN-BURNERS AND GRATES

The grates can be removed and cleaned with a solution of hot water and strong soap or detergent. The burners themselves require little attention, but if spillage should occur, it may be necessary to clean around pilot areas, air mixer and under burners. Use a wire brush if necessary. Periodically, open-burners should be removed and cleaned. Allow the interior of the burner to drain, and dry thoroughly before replacing.

## HOT-TOP SURFACES

Before cleaning hot-top surfaces, allow them to cool. If water is used on hot-tops while they are still hot, they may crack, so avoid this practice. The hot-top plates can be removed and cleaned with hot water and detergent. A wire brush may be used on the underside of the hot top plate. It is recommended not to clean tops while still on the range, even if cooled, as excess water will drip into the burner box and deteriorate the metal.

## CARE OF GRIDDLES

A griddle should be carefully cared for in order to avoid possible damage. (The griddle should have been tempered as part of the installation procedure, see page 28). Use a Norton Alundum Griddle Brick to clean the griddle. Do not use any type of steel wool. Small particles may be left on the surface and get into food products. Do not clean spatula by hitting the edge on the griddle plate. Such action will only cut and pit the griddle plate, leaving it rough and hard to clean.

## OVEN INTERIOR

### **WARNING**

FOR YOUR SAFETY, DISCONNECT THE POWER SUPPLY TO THE SECTIONAL RANGE BEFORE CLEANING THE OVEN. WHEN CLEANING THE BLOWER WHEEL OF A CONVECTION OVEN, BE SURE TO HAVE THE POWER SWITCH IN THE “OFF” POSITION.

To clean the oven interior, first allow the oven to cool. Remove oven bottom and clean it by rubbing with strong detergent and a Brillo pad or similar scrubber. “Spillovers” should be cleaned from the bottom as soon as possible to prevent carbonizing and a “burnt-on” condition. For stubborn accumulations, commercial oven cleaners are recommended.

The porcelain oven door lining can be cleaned in a similar manner. The side, rear and top lining should be wiped only with a cloth dampened with a mild detergent and water. Avoid using excessive amounts of water, as this may drip into burner compartment and deteriorate the metal in that area. Do not use strong commercial cleaners or abrasive pads on the side, rear or top linings, as they may damage the finish or leave gray residue

# INSTALLATION

## NOTICE

These installation procedures must be followed by qualified personnel or warranty will be void.

Local codes regarding installation vary greatly from one area to another. The National Fire Protection Association, Inc., states in its NFPA 96 latest edition that local codes are the "authority having jurisdiction" when it comes to installation requirements for equipment. Therefore, installations should comply with all local codes.

The installation must conform with local codes, or in the absence of local codes, with the National Fuel Gas Code, ANSI Z223.1, Natural Gas Installation Code, CAN/CGA-B149.1, or the Propane Installation Code CAN/CGA-B149.2, as applicable, including:

1. The appliance and its individual shutoff valve must be disconnected from the gas supply piping system during any pressure testing of that system at test pressures in excess of 1/2 psi (3.45 kPa).
2. The appliance must be isolated from the gas supply piping system by closing its individual manual shutoff valve during any pressure testing of the gas supply piping system at test pressures equal to or less than 1/2 psi (3.45 kPa).

## NOTICE

In the Commonwealth of Massachusetts all gas appliances vented by either mechanical systems or ventilation hoods shall comply with 248 CMR interlocking requirements.

This installation procedure does NOT cover Southbend sectional fryers, fryer filter systems, salamander broilers, upright broilers, cheese melters, or refrigerated bases. Consult the manuals of those appliances when they are being installed as part of a sectional range battery.

## STEP 1: UNPACKING

### IMMEDIATELY INSPECT FOR SHIPPING DAMAGE

All containers should be examined for damage before and during unloading. The freight carrier has assumed responsibility for its safe transit and delivery. If damaged equipment is received, either apparent or concealed, a claim must be made with the delivering carrier.

Apparent damage or loss must be noted on the freight bill at the time of delivery. The freight bill must then be signed by the carrier representative (Driver). If the bill is not signed, the carrier may refuse the claim. The carrier can supply the necessary forms.

A request for inspection must be made to the carrier within 15 days if there is concealed damage or loss that is not apparent until after the equipment is uncrated. The carrier should arrange an inspection. Be certain to hold all contents plus all packing material.

For each section, do the following:

1. Cut the banding straps and remove the corrugated cardboard surrounding the section. (If legs, casters, a flue riser, and/or shelf components were shipped in the same container, set them aside for installation in later steps of this procedure. Do not remove any tags or labels attached to the range until the range is installed and working properly.
2. Cut the banding strap holding the range to the wooden skid.
3. Unbolt the shipping hold-down brackets from the skid, then remove the brackets from the appliance (see Figure 12).
4. If the range is to be installed on 6" legs, go to Step 2a.  
If the range is to be installed on 6" casters, go to Step 2b.  
If the range is to be installed on a caster-frame, go to Step 2c.

Figure 12

## Removal of Shipping Hold-Down Brackets

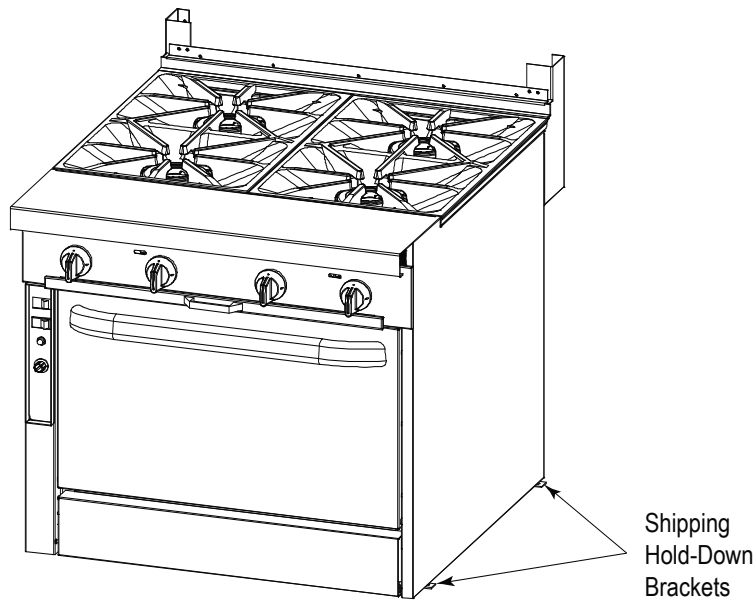

## STEP 2A: ATTACH LEGS

A set of four legs is packed with units ordered with legs. (For units ordered with casters, go to Step 2b.)

A threaded leg pad is fastened to the base frame at each corner. Each leg has a corresponding mating thread. The legs can be adjusted to overcome a slightly uneven floor.

1. Raise the range sufficiently to allow the legs to be attached. For safety, “shore up” and support the range with an adequate blocking arrangement strong enough to support the load.
2. Screw the legs into the holes in the centers of the leg pads (see Figure 13).
3. Lower the range gently onto a level surface. Never drop or allow the range to fall.
4. Go on to Installation Step 4.

Figure 13

## Installation of Legs

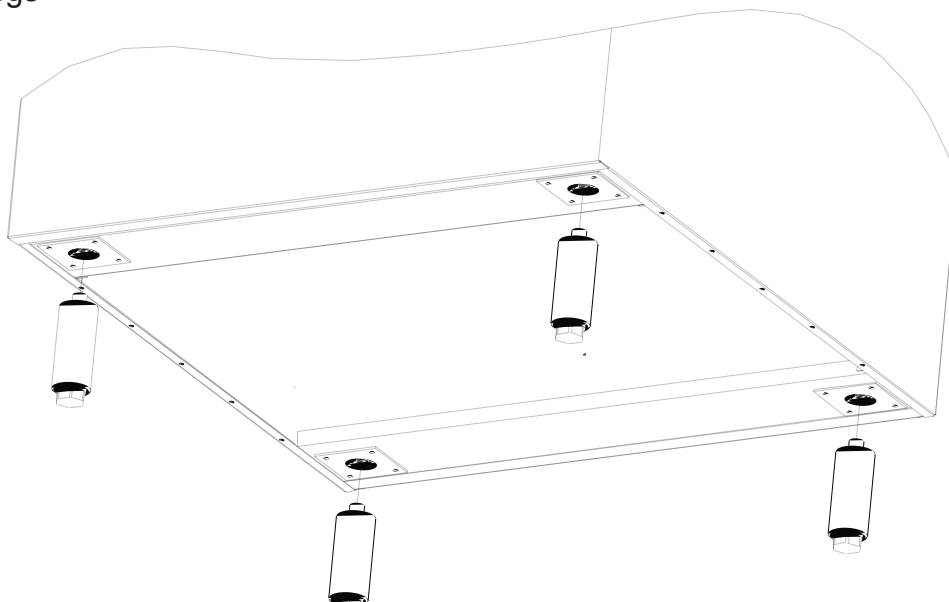

## STEP 2B: ATTACH CASTERS

### NOTICE

For an appliance equipped with casters, (1) the installation shall be made with a connector that complies with the *Standard for Connectors for Movable Gas Appliances, ANSI Z21.69* or *Connectors for Moveable Gas Appliances, CAN/CGA-6.16*, and a quick-disconnect device that complies with the *Standard for Quick-Disconnect Devices for Use With Gas Fuel, ANSI Z21.41*, or *Quick Disconnect Devices for Use with Gas Fuel, CAN1-6.9*, (2) adequate means must be provided to limit the movement of the appliance without depending on the connector and the quick-disconnect device or its associated piping to limit the appliance movement and (3) the restraining means should be attached to a frame member on the back of the unit.

A set of four casters is packed with units ordered with casters (instead of legs).

A threaded leg pad is fastened to the base frame at each corner. Each caster has a corresponding mating thread. The casters can be adjusted to overcome a slightly uneven floor. Casters are provided with a Zerk fitting for proper lubrication when required.

1. Raise unit sufficiently to allow the casters to be attached. For safety, "shore up" and support the range with an adequate blocking arrangement strong enough to support the load.
2. Screw the casters into the holes in the centers of the leg pads (see Figure 14). Install the casters that have a locking brake under the front of the range.
3. Lower the range gently onto a level surface. Never drop or allow the range to fall.
4. Go to Installation Step 3.

Figure 14

### Installation of Casters

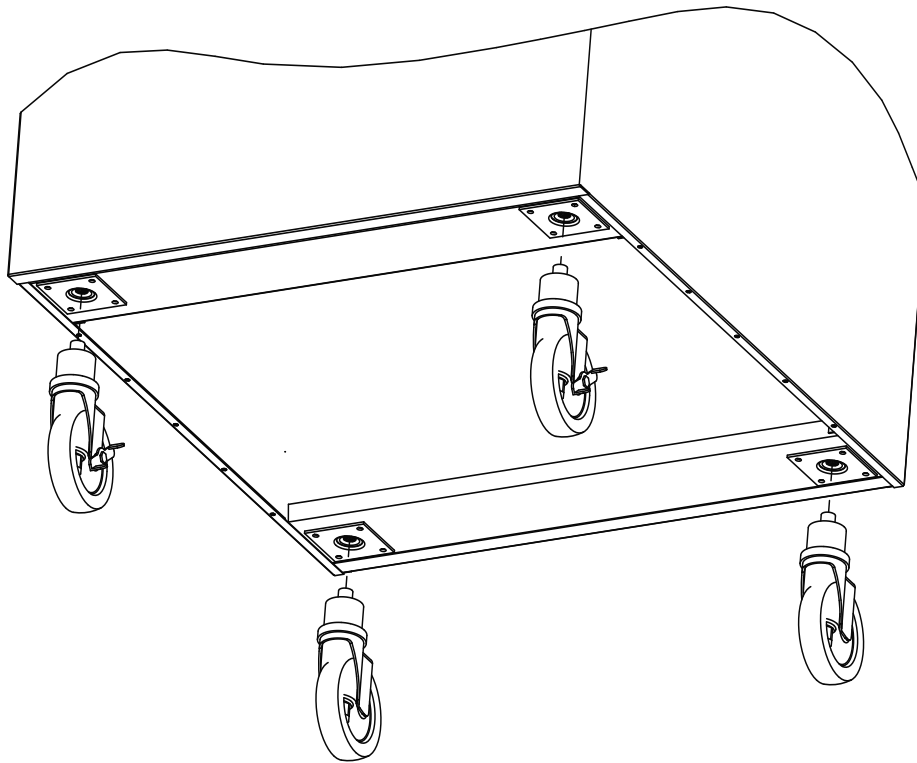



## STEP 2C: MOUNT UNIT ON CASTER FRAME

### NOTICE

For an appliance equipped with casters, (1) the installation shall be made with a connector that complies with the *Standard for Connectors for Movable Gas Appliances, ANSI Z21.69* or *Connectors for Moveable Gas Appliances, CAN/CGA-6.16*, and a quick-disconnect device that complies with the *Standard for Quick-Disconnect Devices for Use With Gas Fuel, ANSI Z21.41*, or *Quick Disconnect Devices for Use with Gas Fuel, CAN1-6.9*, (2) adequate means must be provided to limit the movement of the appliance without depending on the connector and the quick-disconnect device or its associated piping to limit the appliance movement and (3) the restraining means should be attached to a frame member on the back of the unit.

The range can be mounted on an optional caster frame. The frame will have a threaded leg pad at each corner. Each caster has a corresponding mating thread. The casters can be adjusted to overcome a slightly uneven floor. Casters are provided with a Zerk fitting for proper lubrication when required.

1. Assemble the caster frame components.
2. Screw the casters into the holes in the centers of the leg pads of the caster frame. Install the casters that have a locking brake under the front of the battery.
3. Lower the caster frame gently onto a level surface. Never drop or allow the frame to fall.
4. Block and brace the frame so that it will not move while the battery sections are installed on it.
5. Lift and gently place the range in position on the caster frame. Never drop or allow the range to fall.
6. Bolt the range to the caster frame.
7. Go to Installation Step 3.

## STEP 3: ATTACH RESTRAINT TO UNIT MOUNTED ON CASTERS

### NOTICE

For an appliance equipped with casters, (1) the installation shall be made with a connector that complies with the *Standard for Connectors for Movable Gas Appliances, ANSI Z21.69* or *Connectors for Moveable Gas Appliances, CAN/CGA-6.16*, and a quick-disconnect device that complies with the *Standard for Quick-Disconnect Devices for Use With Gas Fuel, ANSI Z21.41*, or *Quick Disconnect Devices for Use with Gas Fuel, CAN1-6.9*, (2) adequate means must be provided to limit the movement of the appliance without depending on the connector and the quick-disconnect device or its associated piping to limit the appliance movement and (3) the restraining means should be attached to a frame member on the back of the unit.

Install the restraint cable to a range (or battery) mounted on casters using the following procedure:

1. Secure the restraining-device bracket (item "B" in Figure 15) to a wall stud located as close as possible to the appliance connector inlet and outlet connections. Use four #12 screws (items "C") and plastic anchors (items "A") if necessary.
2. Install eye-bolt (item "F") to a frame member on the rear of the equipment. After checking carefully behind the frame member for adequate clearance, drill a 1/4" hole through the frame member.
3. Thread hex nut (item "G") and slide the washer (item "H") onto the eye-bolt. Insert the eye-bolt through the 1/4" drilled hole and secure with a washer (item "H") and nylon lock nut (item "I").
4. Using the spring-loaded snap hooks, attach the restraining device to the bracket and the eye-bolt.
5. Using the cable clamp (item "D"), adjust the restraining device extended length to prevent over-bending or kinking of the appliance connector.

For units not equipped with flame safety devices, be sure all valves are turned off prior to disconnecting. After reconnecting, be sure all control knobs are turned off and all pilots are lit.

**NOTICE**

Adequate means must be provided to limit the movement of the appliance without depending on the connector and the quick-disconnect device or its associated piping to limit the appliance movement.

The restraining means should be attached to a frame member on the back of the unit.

Figure 15

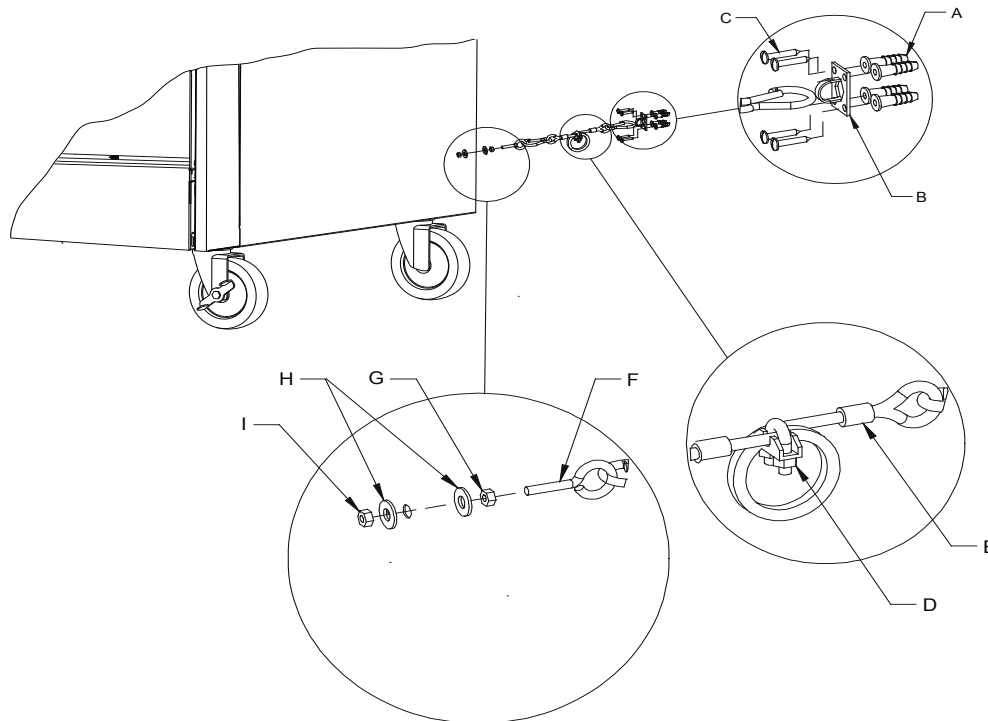
**Installation of Cable Restraint****STEP 4: CONNECT BATTERY SECTIONS**

If the range is part of a battery, and the battery was shipped partially disassembled, connect the battery sections using the following procedure.

1. Remove valve panels from all sections. Mark them so that they can be returned to their respective section.
2. Position the center section of the battery and carefully level that unit. Use a long spirit level four ways; across front top rail and the rear edge, and along each side edge.
3. If not already in place, attach pipe-union to front manifold of the battery. Screw it in far enough to be able to slide the adjacent section into position.
4. Bring up adjacent section and level it using the same method and by using the center unit as reference. Match front rails and rear edge. When a battery is set on a masonry base and legs are not used, shims may be used. Special attention should be given to griddle ranges to allow proper drainage.
5. Bolt the frames of the sections together.
6. Connect the front manifolds using the pipe-union.
7. Attach the trim-strip between the section tops.
8. Install the continuous front-rail, if ordered.
9. Slide control knobs onto their shafts (to operate the sections during the installation procedure), but do not yet reattach valve panels or front-panel trim pieces.

## STEP 5: ATTACH FLUE RISER AND SHELF ASSEMBLIES

Install the flue riser(s) using the following procedure (as shown in Figure 16).

1. Attach any salamander broilers and flue-riser-mounted cheese melters to appropriate sections following the installation procedure in the manuals for those options.
2. Slide each flue riser down onto the brackets projecting from the back of the corresponding section(s) of the sectional range. Secure the flue riser to the brackets with the four provided 1/4-20x3/4 hex-head bolts, flat washers, and lockwashers. Also, secure the bottom edge of the flue riser to the top rear edge of the sectional range using the provided #10 sheet metal screws.
3. If access to the interior of the flue riser is necessary to make gas connections, make those connections at this time.

Figure 16

### Installation of Flue Riser

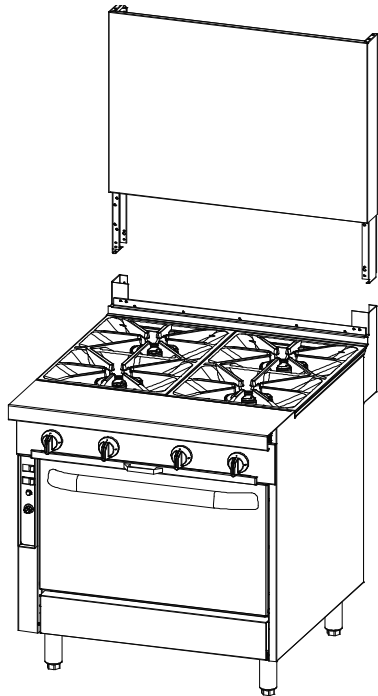

Slide the front of the flue riser down into the brackets on the sectional range.

Secure the flue riser to the brackets using the provided fasteners. Also secure the bottom edge of the flue riser to the top rear edge of the sectional range.

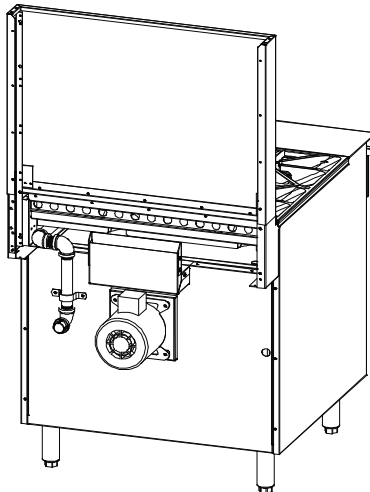

Attach the rear of the flue riser to the front of the flue riser using the provided fasteners.

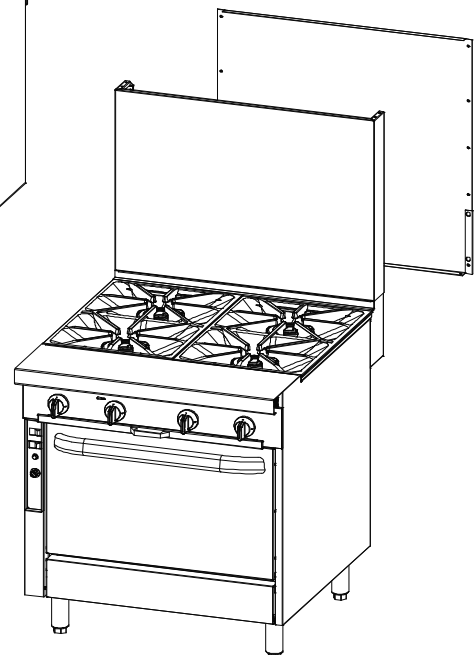

4. Attach each wall shield to the back of the corresponding flue riser using the provided #10 sheet metal screws.
5. Connect the top side edges of adjoining flue risers using the provided small plates and screws.
6. If tubed shelves were installed, place the tubes in place in the shelf brackets.
7. If sloped enclosures were ordered (for flue-mounted salamander broilers and/or cheese melters), install them at this time.

## STEP 6: CONNECT ELECTRICITY (FOR SECTIONS WITH OVEN-BASES)

A wiring diagram is located behind the kick panel of the oven-base ranges. Be sure that the input voltage and phase match the requirements shown on the serial plate.

Oven-base ranges ordered with a 115V, 60Hz, single-phase electrical rating are factory-supplied with a three-wire cord with a three-prong plug that fits any standard three-prong grounded receptacle. Each standard oven requires a 15 ampere supply, while each convection oven requires a 20 ampere supply.

Oven-base ranges ordered with a 208/236V, 60Hz, single- or three-phase electrical rating are factory-equipped with a two-pole terminal block located behind cover plate located on the rear of the unit. To connect the supply wires, remove the cover plate. Route the supply wires and the grounding wire through the strain relief fitting to the terminal block. Insert the supply wires, one each, into the two poles of the terminal block and tighten the screws. Insert the ground wire into the grounding lug and tighten the screw. Re-attach the cover plate.

Three phase units are wired as above, using only two supply wires. The third wire is not used and must be properly terminated.

All units are shipped wired as specified by factory order. Conversion between single-phase and three-phase can be accomplished by referring to phase loading and line amperes chart on the wiring diagram for wire size and ampere requirements.

## STEP 7: CONNECT GAS SUPPLY

If the sectional range is being installed at over 2,000 feet altitude and that information was not specified when ordered, contact the appropriate authorized Southbend Service Representative or the Southbend Service Department. Failure to install with proper orifice sizing will result in poor performance and may void the warranty.

The sectional range is design-certified for operation on natural or propane gases. The sectional range is shipped configured and adjusted for the type of gas specified by the purchaser, which is indicated on the serial plate (see Figure 1 on page 3). Connect the sectional range ONLY to the type of gas for which it is configured and adjusted.

Minimum supply pressure is 7" W.C. for natural gas, 11" W.C. for propane. An external pressure regulator and shut off valve are provided. If using a flexible-hose gas connection, the I.D. of the hose must not be smaller than the connector on the sectional range, and must comply with ANSI Z21.69. Provide an adequate means of restraint to prevent undue strain on the gas connection.

If applicable, the vent line from the gas pressure regulator shall be installed to the outdoors in accordance with local codes, or in the absence of local codes, with the National Fuel Gas Code, ANSI Z223.1, Natural Gas Installation Code, CAN/CGA-B149.1, or the Propane Installation Code CAN/CGA-B149.2, as applicable.

An adequate gas supply is imperative. Undersized or low pressure lines will restrict the volume of gas required for satisfactory performance. Fluctuations of more than 25% on natural gas or 10% on propane gas will create problems and affect burner operating characteristics. A 1/8" pressure tap is located on the manifold to measure the manifold pressure. The supply line to the sectional range should be no smaller than the inside diameter of the pipe on the sectional range to which it is connected.

### CAUTION

ALL PIPE JOINTS AND CONNECTIONS MUST BE TESTED THOROUGHLY FOR GAS LEAKS. USE ONLY SOAPY WATER FOR TESTING ON ALL GASES. NEVER USE AN OPEN FLAME TO CHECK FOR GAS LEAKS. ALL CONNECTIONS MUST BE CHECKED FOR LEAKS AFTER THE APPLIANCE HAS BEEN PUT INTO OPERATION. TEST PRESSURE SHOULD NOT EXCEED 14" W.C

Do the following to connect the gas supply:

1. Check that all control knobs on the sectional range are in the OFF position.
2. Purge the gas supply line to clean out dust, dirt, or other foreign matter before connecting the line to the sectional range.

3. The gas connection piping may have been partially installed at the factory. If necessary, attach the gas connection of any appliances mounted on a flue riser.
4. Locate the pressure regulator(s) packed with the sectional range. Install the pressure regulator, taking care that the direction of gas flow corresponds to the arrow on the side of the pressure regulator.

 **CAUTION**

HOLD THE PRESSURE REGULATOR WITH A WRENCH WHEN TIGHTENING THE CONNECTION TO THE SUPPLY PIPE TO AVOID DAMAGE TO THE REGULATOR, VALVE, AND OTHER COMPONENTS.

5. Install a service shut-off valve to the pressure regulator, and connect the gas supply line to the shut-off valve.
6. If applicable, install the vent line of the pressure regulator to the outdoors.
7. Turn on the gas and immediately check for leaks using soapy water.
8. If the optional sloped enclosure for a flue-mounted model was ordered, install it at this time.

## STEP 8: CONNECT WATER SUPPLY

If a rail-mounted fill-hose was ordered (as a special option), there will be a corresponding water connection on the back of the section. Connect the water supply.

## STEP 9: CHECK THE INSTALLATION

Check the installation, as follows:

1. Check that all screws and bolts are tightened.
2. Check electrical connection(s).
3. Check that the gas connection has been made correctly.
4. Check water connection(s).
5. Move the battery into the final position at which it will be operated.
6. Check that the battery is level. If not, adjust the legs or casters.
7. Check that the appropriate minimum clearances are satisfied (see page 4).
8. Check that there is sufficient clearance to open all doors and pull-out all grease trays and crumb trays.
9. Check that adequate ventilation (fresh air supply and hood exhaust) is available to the room in which the appliance will operate.
10. Wipe clean all cooking surfaces (especially griddles).
11. Check that nothing is obstructing the air intake openings and/or the combustion-exhaust openings.

## STEP 10: CHECK OPERATION OF EACH SECTION

Check the operation of each section, as follows:

1. Turn electricity supply on.
2. Turn gas supply on. Immediately check all gas connections for leaks using soapy water.
3. Turn water supply on (if applicable). Check for water leaks.
4. Light all pilots (see the appropriate Operation section elsewhere in this manual). Start with the section(s) furthest from the gas supply connection(s) to purge air from the gas lines. Check all pilots for correct flame height.
5. Turn on the burners of each section using only the lowest temperature settings (for now). Check all burners for correct flame appearance and height.
6. Begin to break-in all griddle surfaces by turning on all griddle burners to LOW for at least one hour. (In case any problems occur, do not leave the battery unattended during this time!) This will temper the griddle surface and avoid possible damage.
7. Check operation of all sections (except griddles) for the full-range of operating settings, including checking all burners for correct flame appearance and height at the HIGH settings.
8. Complete the break-in of all griddle surfaces (after they have been operating at LOW for at least one hour) by gradually bringing each griddle up to frying temperature. Then spread over each griddle three or four ounces of

beef suet, or as a substitute, baking soda, to season it. Never allow water on a hot griddle and never wash it with soap and water.

9. Check that gas supply is adequate by simultaneously turning on all burners of all sections to their highest setting, then again checking that all burner flames have correct appearance and height.
10. Check that electricity supply is adequate by simultaneously turning on all electrical elements (if any) and turning the blower setting of all convection ovens (if any) to HIGH.
11. Check that water supply is adequate by simultaneously operating all fill hoses (if any). (Do not allow water to spill onto a hot griddle.)
12. Turn-off all burners and allow all battery sections to cool.

## STEP 11: ATTACH VALVE-PANEL(S) AND FRONT TRIM PANELS

Attach the valve panel(s) and front trim panels, as follows:

1. After the battery has cooled, again check all gas connections for gas leaks using soapy water.
2. Attach the front-trim panels for the adjoining sections.
3. Remove control knobs, grease drawers, and drippings-trays as necessary to enable installation of the valve panel(s).
4. Attach the valve panel(s).
5. Re-attach the control knobs. Insert all grease drawers and drippings trays.

## STEP 12: WIPE-CLEAN AND SHUT-DOWN RANGE

Complete the installation by leaving the sectional range ready for customer use:

1. Wipe clean all surfaces.
2. Unless the sectional range is to be placed in service immediately, shut off the gas, electricity, and water supplies.
3. Make sure that a copy of this manual will be available to the people who will operate and maintain the sectional range.

# SERVICE

## WARNING

Improper ventilation can result in personal injury or death. Ventilation which fails to properly remove flue products can cause headaches, drowsiness, nausea, or could result in death.

All gas appliances must be installed in such a manner that the flow of combustion and ventilation air is not obstructed. Provisions for adequate air supply must be provided. Do not obstruct the area under the control panel or below the oven door (on the front), or the area below the flue riser (on the back) as combustion air enters through these areas.

## NOTICE

Improper ventilation can result in personal injury or death. Ventilation which fails to properly remove flue products can cause headaches, drowsiness, nausea, or could result in death.

All gas appliances must be installed in such a manner that the flow of combustion and ventilation air is not obstructed. Provisions for adequate air supply must be provided. Do not obstruct the area under the control panel or below the oven door (on the front), or the area below the flue riser (on the back) as combustion air enters through these areas.

The location of the serial plate depends on the type of base (see Figure 1 on page 3). On models with oven bases, the serial plate is located on the backside of the kick-plate below the oven door (lift the kick-plate straight up and tilt the top edge out and down.) On models with a cabinet base, the serial plate is located inside the left cabinet door. On modular (countertop) models, the serial plate is located inside the front valve panel.

Replacement parts (including parts not listed in this manual) may be ordered either through a Southbend Authorized Parts Distributor or a Southbend Authorized Service Agency.

When ordering parts, please supply the Model Number, Serial Number, Part Number, and Part Description.

## ACCESS TO SERVICEABLE COMPONENT

To open the kick panel below the oven door, lift the kick panel straight up and pull the top edge away from the oven. The kick panel is hinged at the bottom corners.

To remove the valve panel, first remove the knobs. Then remove the two screws on the bottom of the valve panel (except on modular-countertop base models). Pull the bottom of the valve panel away from the range. The top edge of the valve panel has two small slots that hook over tabs on the frame.

To access the rear of the oven control panel, first remove the valve panel. Then remove the screw that holds the top of the oven control panel in place. Tilt the top of the oven control panel outward, being careful not to damage the wires or the thermostat sensor.

To service the blower motor from the front of the oven, first remove the blower baffle from the rear of the oven cavity (lift it up and out). Then disconnect the motor-mount plate by removing the eight hex nuts that secure it to the oven interior back. Pull the mount-plate, with motor attached, into the oven cavity.

## TROUBLESHOOTING BURNERS AND PILOTS

The following table lists the possible causes of burner and pilot related problems that may occur.

<b>Problem</b>	<b>Look for -</b>
None of the burners and pilots will turn on later...	– Main gas supply to unit is OFF.
All burners produce excessive carbon deposits	– Incorrect gas type is being supplied to the range – Primary air not adjusted properly.
Only some burners produce excessive carbon deposits	– Incorrect orifices. – Primary air not adjusted properly.
Only some pilots produce excessive carbon deposits	– Pilot not adjusted properly. – Incorrect pilot orifice.
Top burner (not oven) will not come on	– Pilot out. – For thermostatic griddles, gas shut off valve is in OFF position. – For thermostatic griddles, button on safety switch is not being held in long enough after lighting pilot.
Top section pilot will not remain lit	– Pilot flame not adjusted properly. – Clogged orifice. – Draft condition. – Improper ventilation system. – Air in gas line.

## SERVICING BURNERS AND PILOTS

All orifice sizes and burner rates are properly set at the factory and should not be altered.

Each burner should have a steady blue flame on each port of the burner. When using propane, the burners may have a small amount of yellow tipping.

If the flame is rising up off of the ports adjust the burner shutter to be further closed. If the flame is long and yellow adjust the burner shutter to be further open.

Over-gassed burners DO NOT heat as efficiently as those that are properly adjusted. Such conditions also create “hot spots” on griddles and hot tops. Floating and unstable burner and pilot flames will result when solid tops are lowered into position because the rear openings of the burner compartment are not adequate to vent the enormous flue products generated by over-gassed burners. The “unburned” gas will ignite at the rear and burn in this section and even up inside the flue riser, causing structural members in this area to deteriorate. Also, some of these hot flue products will vent forward into the manifold compartment resulting in problems with valves and thermostats due to overheating. AGAIN, over-gassed burners waste energy and cause service problems.

Note that the burners of griddle, charbroiler, and uniform hot-top models are long, and so the burner flame may float when cold. Allow the burner to heat before making burner adjustments.

Propane burners may have a slight popping noise when turned off. This is normal.

Check that the burner is level and in its support brackets.

Check that the burner is clean and all of its ports are clear.

Check that each burner valve and orifice is in alignment with the burner.

Remove the burner and check that its venturi is clean and free of buildup and debris.

With each burner removed check that the orifice size is correct and clean and free of buildup and debris.

If it is necessary to remove a griddle top to service the burners, use extreme care since the griddle plate is very heavy. When raising a thermostatic griddle top, remove the thermostat bulbs from the tubes on the bottom of the griddle plate. When re-installing, re-insert the thermostat bulbs and be sure the capillary tubes are away from burners, flames and excessive heat.



Pilot-flame outage is often due to an unstable flame caused by over-adjustment to the point where the pilot flame is leaving its port, or “blowing off.” Sometimes the pilots are increased too much in an effort to improve ignition, resulting in this unstable condition.

Figure 17

### Adjustment of Charbroiler, Standard-Griddle, and Uniform Hot-Top Burners and Pilots

The burner valves are not adjustable. The burner orifice is of the fixed type, sized for the type of gas and the operating altitude. To adjust the burner air-gas mixture, loosen the screw that secures the air shutter on the mixer face and rotate the mixer cap to obtain a clear, stable blue flame with a distinct inner cone at each port. Excessive primary air causes “blowing” (the flames leaving the ports), while insufficient primary air causes a soft or yellow tipped flame.

The pilots are near the front of the burners, and are held in position by brackets. To adjust a pilot flame, insert a screwdriver through the opening in the valve panel between the control knobs and turn the appropriate pilot adjustment screw counterclockwise to increase the size of the pilot flame, or clockwise to decrease the size of the pilot flame. The maximum flame size is approximately 3/4” with a slight yellow tip. The first indication of over-adjustment is when the flame tip becomes more yellow and begins to generate carbon, which appears as rising black streaks.

Continued over-adjustment leads to unstable lifting and a blowing condition.

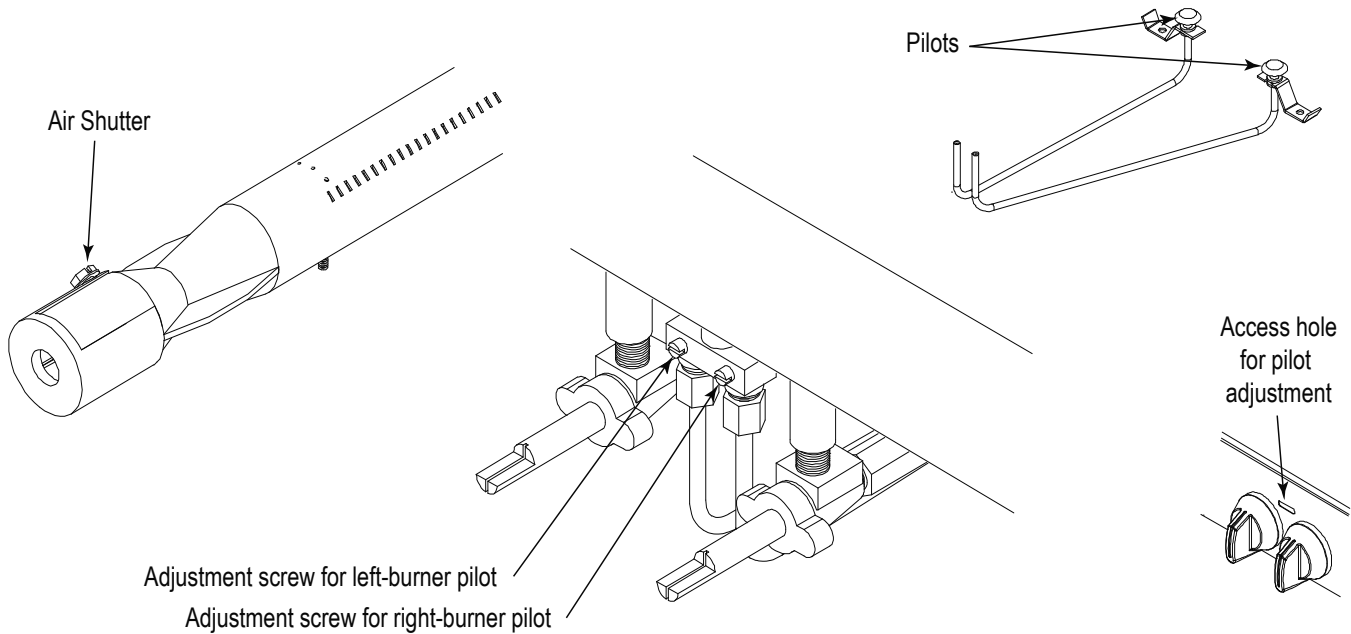

Figure 18

### Adjustment of Graduated Hot-Top Pilot and Burner

The burner valves are not adjustable. The burner orifice is of the fixed type, sized for the type of gas and the operating altitude. To adjust the burner air-gas mixture, loosen the screw that secures the air shutter on the mixer face and rotate the mixer cap to obtain a clear, stable blue flame with a distinct inner cone at each port. Excessive primary air causes "blowing" (the flames leaving the ports), while insufficient primary air causes a soft or yellow tipped flame.

The pilot is beside the burner, and is held in position by a bracket. To adjust the pilot flame, insert a screwdriver through the opening in the valve panel beside the control knob and turn the pilot adjustment screw counterclockwise to increase the size of the pilot flame, or clockwise to decrease the size of the pilot flame. The maximum flame size is approximately 3/4" with a slight yellow tip. The first indication of over-adjustment is when the flame tip becomes more yellow and begins to generate carbon, which appears as rising black streaks. Continued over-adjustment leads to unstable lifting and a blowing condition.

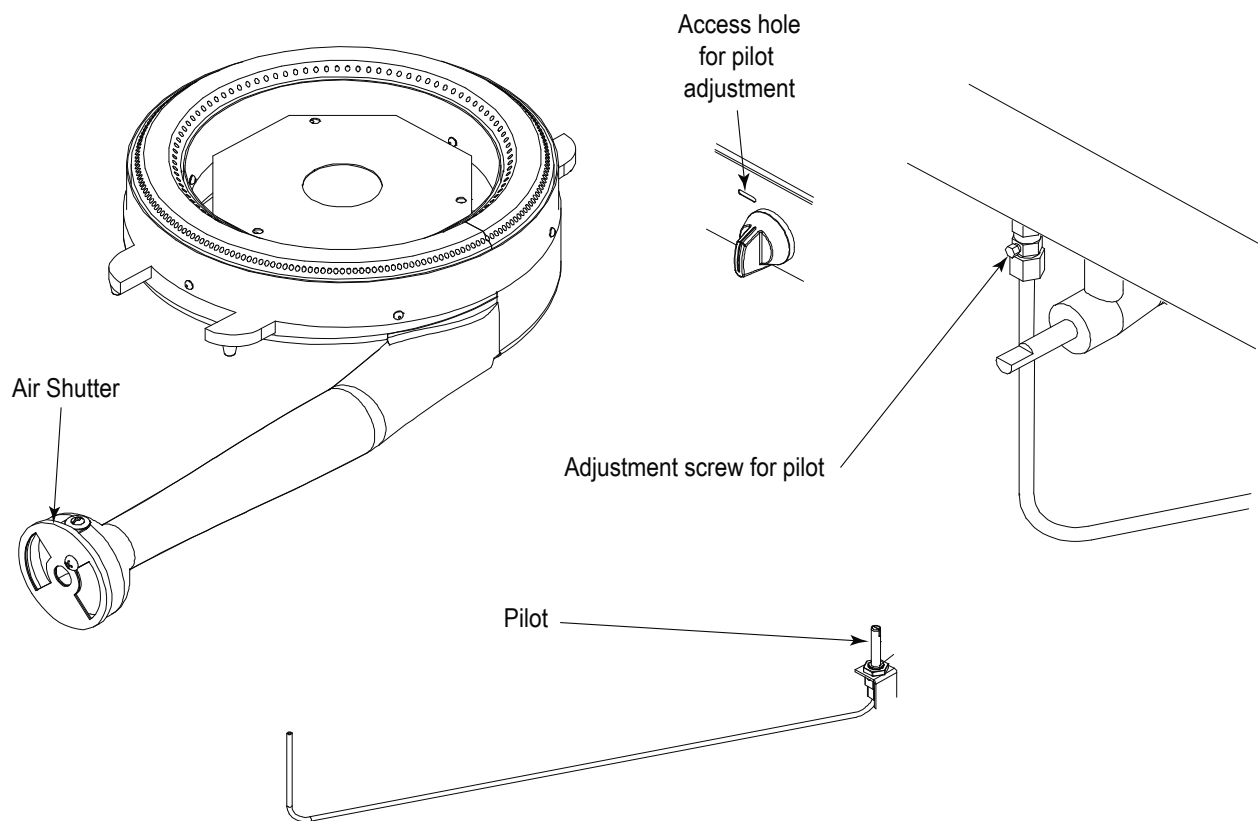

Figure 19

### Adjustment of 33K and 45K Open-Top Burners and Pilots

The burner valves are not adjustable. The burner orifice is of the fixed type, sized for the type of gas and the operating altitude. To adjust the burner air-gas mixture, loosen the screw that secures the air shutter on the mixer face and rotate the mixer cap to obtain a clear, stable blue flame with a distinct inner cone at each port. Excessive primary air causes "blowing" (the flames leaving the ports), while insufficient primary air causes a soft or yellow tipped flame.

The pilot is beside the burner, and is held in position by a bracket. To adjust the pilot flame, insert a screwdriver through the opening in the valve panel beside the control knob and turn the pilot adjustment screw counterclockwise to increase the size of the pilot flame, or clockwise to decrease the size of the pilot flame. The maximum flame size is approximately 3/4" with a slight yellow tip. The first indication of over-adjustment is when the flame tip becomes more yellow and begins to generate carbon, which appears as rising black streaks. Continued over-adjustment leads to unstable lifting and a blowing condition.

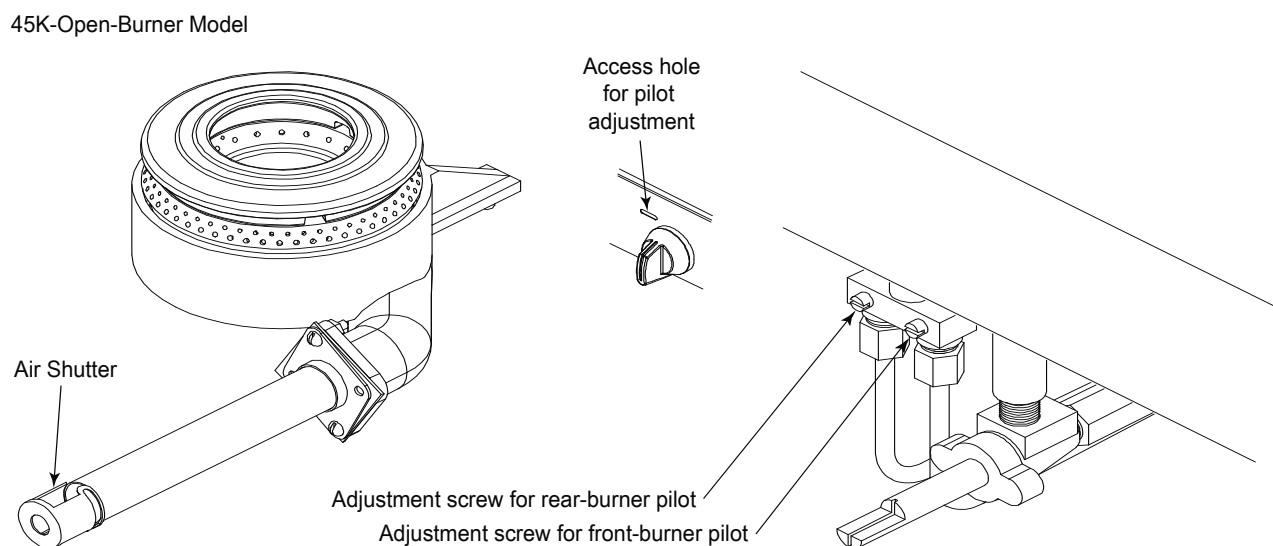
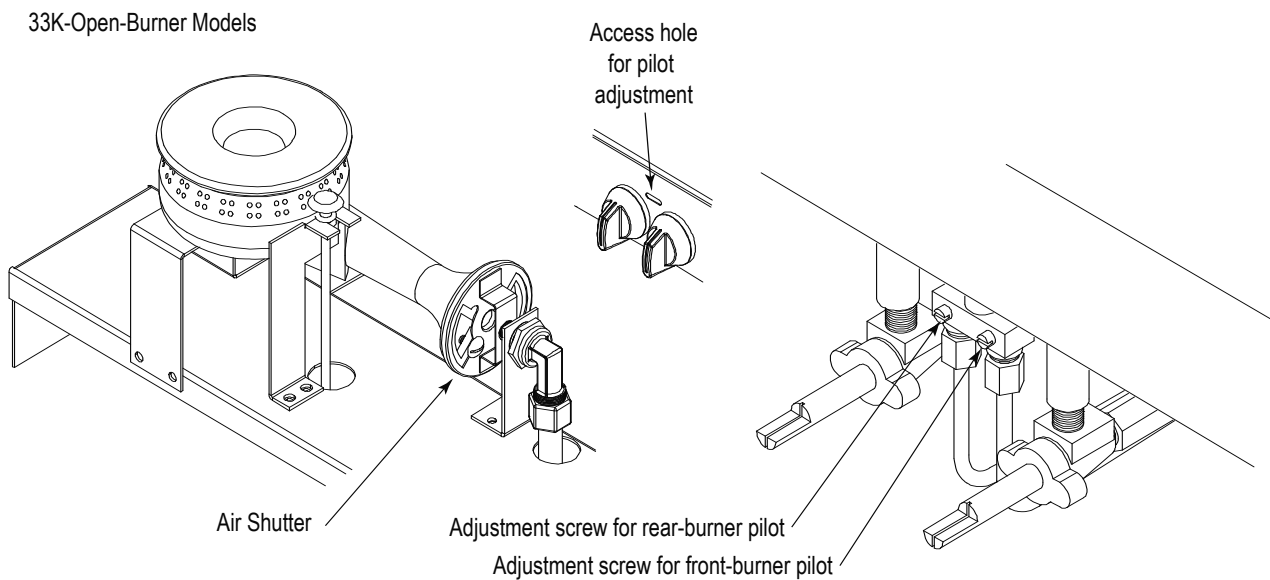

Figure 20

### Adjustment of Thermostatic-Griddle Thermostat

Each 16"-wide section of a thermostatic griddle has a control knob that operates a snap-action thermostatic valve. Each valve is adjusted at the factory. If the griddle surface temperature is different from the thermostat dial setting, adjust the thermostatic valve using the following procedure:

1. Turn all the control knobs to the 300°F.
2. Wait 30 minutes for the griddle temperature to stabilize (or 1 hour if the griddle was cold).
3. Place a reliable thermometer or test-instrument thermocouple (able to register 300°F) halfway back from the front to the back of the griddle and directly in line with the 16"-wide section's control knob (see drawing below). Check the temperature of each section every five minutes until the temperature does not change by more than 30°F between two consecutive measurements.
4. If the average temperature of any section is not within 30°F of the knob setting (300°F), adjust the corresponding thermostatic valve. To do so, remove the control knob (being careful to not turn the stem, which would change the temperature setting). While holding the stem in place, turn the calibration screw (see drawing below). If the actual measured temperature is lower than the dial setting, turn the screw counterclockwise. If the measured temperature is higher than the dial setting, turn the screw clockwise. Replace the control knob.
5. Wait for the griddle temperature to stabilize, then again check the temperature (as described above).

Measure temperature of each 16"-wide section half-way back and in line with control knob.

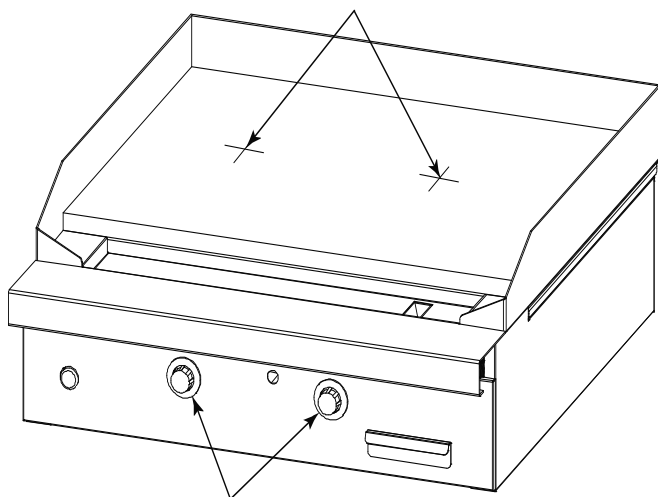

Each knob is attached to a thermostatic valve located behind the valve panel.

With a control knob removed, its valve shaft will extend out of the valve panel.

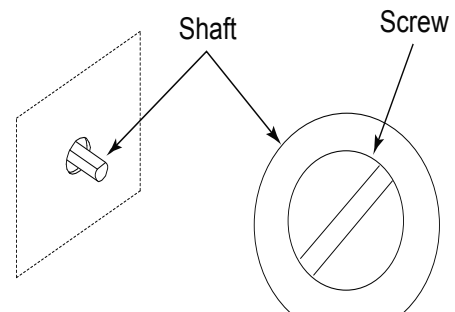

Calibrate the thermostat by holding the shaft in place while turning the screw counterclockwise to increase the temperature, or clockwise to decrease the temperature.

Figure 21

### Adjustment of Thermostatic-Griddle Burners and Pilot

The thermostatic burner valve is adjustable (see page 35). The burner orifice is of the fixed type, sized for the type of gas and the operating altitude. To adjust the burner air-gas mixture, loosen the screw that secures the air shutter on the mixer face and rotate the mixer cap to obtain a clear, stable blue flame with a distinct inner cone at each port. Excessive primary air causes "blowing" (the flames leaving the ports), while insufficient primary air causes a soft or yellow tipped flame.

The pilot(s) and pilot-runner(s) are located near the front of the burners, but the pilot adjustment valve is located in the gas line between the safety switch and the pilot. If the pilot needs adjustment, do the following:

1. Remove the control knobs, and remove the valve panel (see page 30).
2. If necessary, light the pilot.
3. Locate the pilot adjustment valve (see drawing below). Turn the pilot adjustment screw counterclockwise to increase the size of the pilot flame, or clockwise to decrease the size of the pilot flame. The pilot flame should be about 1/2" high with a slight yellow tip, and cover the thermocouple tip. The first indication of over-adjustment is when the flame tip becomes more yellow and begins to generate carbon, which appears as rising black streaks. Continued over-adjustment leads to unstable lifting and a blowing condition.
4. Replace the valve panel and control knobs.

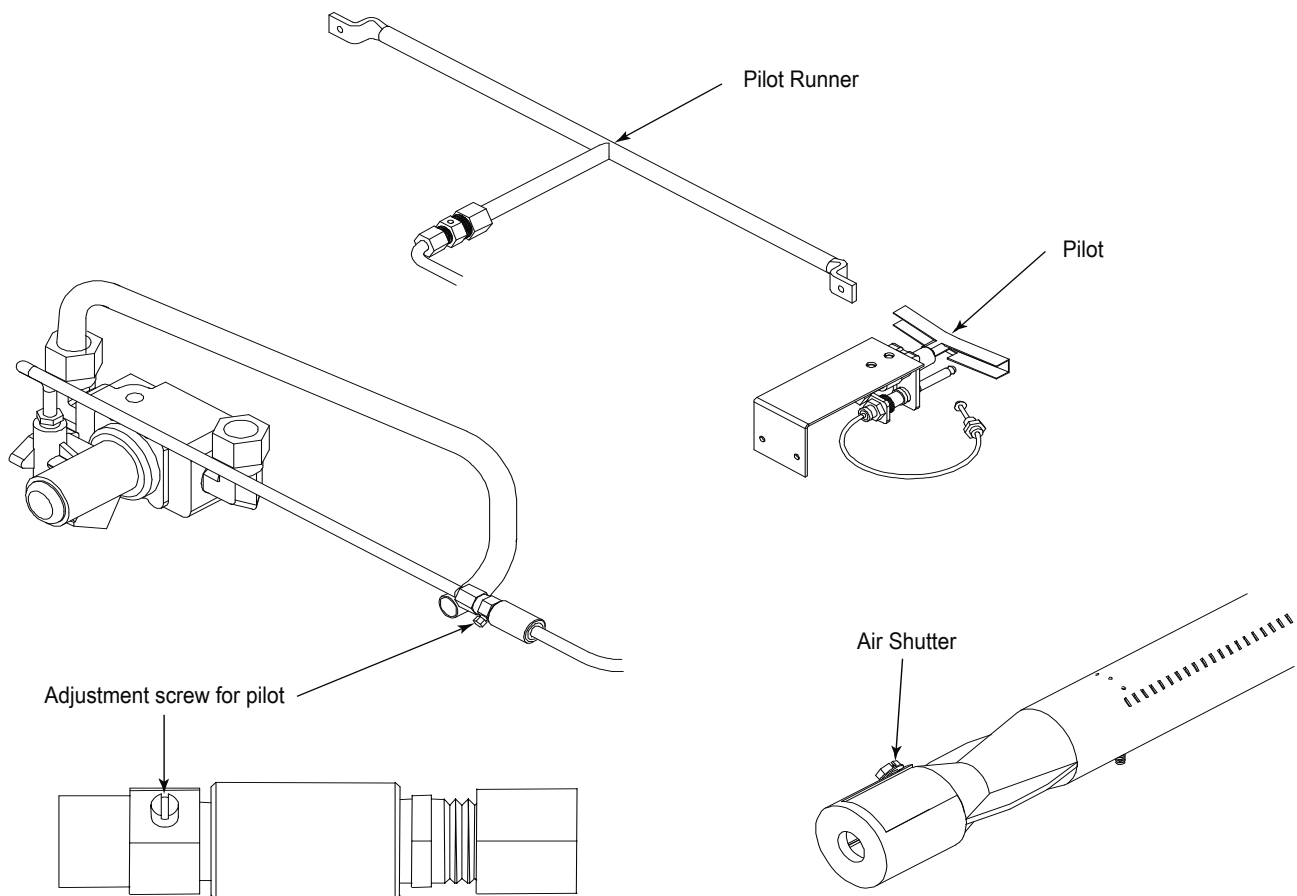

Figure 22

### Adjustment of Oven Thermostat

The oven thermostat is carefully calibrated at the factory so that the dial setting matches the actual oven temperature. Field recalibration is seldom necessary, and should not be resorted to unless considerable cooking experience definitely proves that the control is not maintaining the temperatures to which the dial is set.

Obtain a test instrument or a reliable mercury thermometer, then do the following:

1. Place the thermocouple of test instrument or the thermometer in the middle of the oven.
2. Turn on the oven and set the thermostat to 400°F.
3. After the oven has been on about 20 minutes check oven temperature. The oven door should be open for as short a time as possible. Use a flashlight, if necessary, to see the thermometer clearly.
4. Continue to check the temperature at 5-minute intervals until two successive readings are within 5 degrees of each other.

The thermostat should be recalibrated if the reading is not within 20 degrees of the dial setting (400°F). If calibration is required, adjust the thermostat, as follows:

5. Remove the oven temperature control knob. Be careful to not turn the stem (which would change the temperature setting).
6. While holding the stem in place, turn the calibration screw (see drawing below). If the actual measured temperature is lower than the dial setting, turn the screw counterclockwise. If the measured temperature is higher than the dial setting, turn the screw clockwise. Replace the control knob.
7. Set the oven temperature to 450°F. After about 20 minutes, check the oven temperature. Continue to check the temperature at 5-minute intervals until two successive readings are within 5 degrees of each other. If the actual oven temperature is not within 20 degrees of the dial setting (450°F), replace the thermostat.

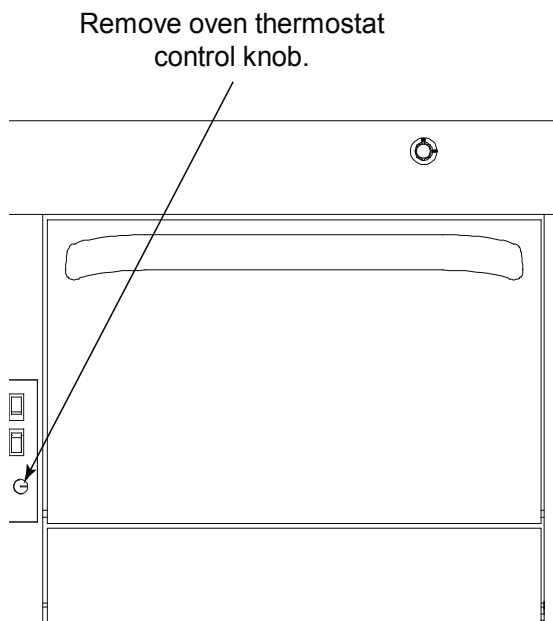

With the control knob removed, the control shaft will extend out of the control panel.

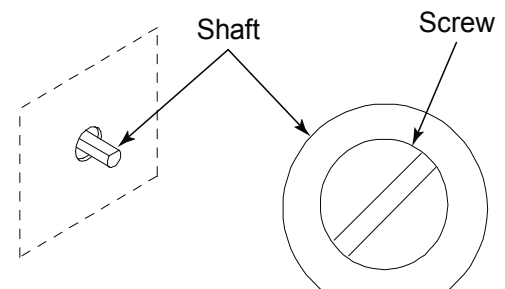

Calibrate the thermostat by holding the shaft in place while turning the screw counterclockwise to increase the temperature, or clockwise to decrease the temperature.

Figure 23

### Adjustment of Oven Pilot and Burner

The burner orifice is of the fixed type, sized for the type of gas and the operating altitude. To adjust the burner air-gas mixture, loosen the screw that secures the air shutter on the mixer face and rotate the mixer cap to obtain a clear, stable blue flame with a distinct inner cone at each port. Excessive primary air causes “blowing” (the flames leaving the ports), while insufficient primary air causes a soft or yellow tipped flame.

The oven pilot flame is adjusted by using a screwdriver to turn the adjusting screw on the pilot line valve (see drawing below). The pilot line valve is located behind the kick panel below the oven door. To gain access, lift the kick panel straight up and pull the top edge out. The pilot flame is properly adjusted when it is just large enough to maintain a glowing red color of the flame switch capillary bulb. The first indication of over-adjustment is when the flame tip becomes yellow and begins to generate carbon, which appears as rising black streaks. Continued over-adjustment leads to unstable lifting and a blowing condition

#### UNITS WITH ELECTRONIC IGNITION

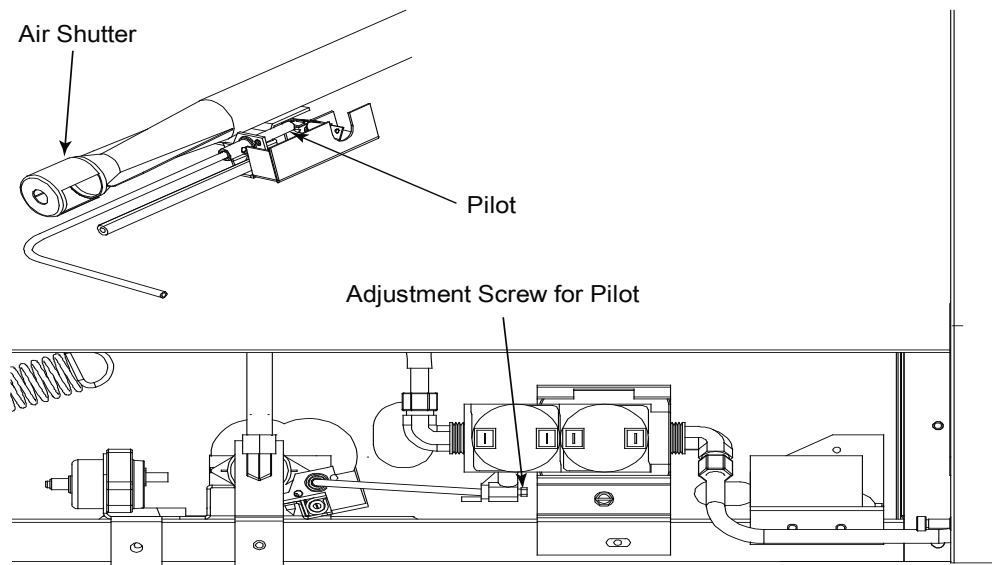

#### UNITS WITH STANDING PILOT

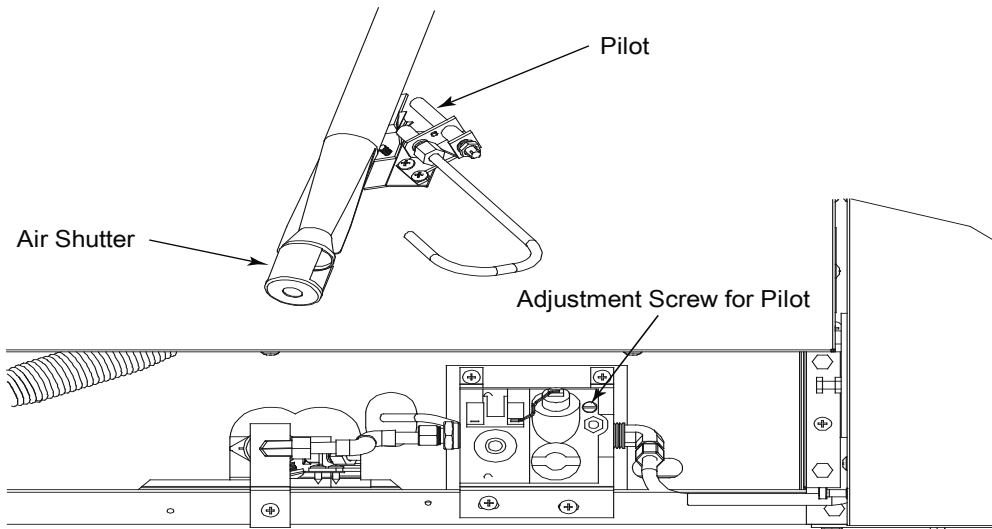

## ADJUSTMENT OF MANIFOLD GAS PRESSURE

There is not an internal pressure regulator. The external pressure regulators supplied by Southbend are factory set at 6" W.C. for natural gas and 10" W.C. for propane gas. To check the manifold pressure, do the following:

1. Turn OFF all thermostats, burner controls, gas shut-off valves, and the external gas supply connection(s).
2. Remove the valve panel and locate the 1/8" plug in the front manifold furthest from the gas connection location. Remove the plug and install a fitting appropriate to connect a manometer.
3. Turn ON all gas supply valves and light all pilots.
4. Turn all burners and ovens to full ON position and read manometer.
5. If manometer does not read 6" W.C. for natural gas (or 10" W.C. for propane gas) adjust regulator by removing the cap from the top of regulator. Use a screwdriver to rotate the regulator adjustment screw clockwise to increase pressure, or counterclockwise to decrease pressure, until manometer shows correct reading.
6. Turn OFF all thermostats, burner controls, gas shut-off valves, and the external gas supply connection(s).
7. Remove manometer fitting and replace plug in manifold.
8. Turn ON all gas valves and light all pilots.
9. Replace valve panel.



# TROUBLESHOOTING

## WARNING

ADJUSTMENTS AND SERVICE WORK MAY BE PERFORMED ONLY BY A QUALIFIED TECHNICIAN WHO IS EXPERIENCED IN, AND KNOWLEDGEABLE WITH, THE OPERATION OF COMMERCIAL COOKING EQUIPMENT. HOWEVER, TO ASSURE YOUR CONFIDENCE, CONTACT YOUR AUTHORIZED SERVICE AGENCY FOR RELIABLE SERVICE, DEPENDABLE ADVICE OR OTHER ASSISTANCE, AND FOR GENUINE FACTORY PARTS.

## NOTICE

Warranty will be void and the manufacturer is relieved of all liability if service work is performed by other than a qualified technician, or if other than genuine Southbend replacement parts are installed.

Replacement parts (including parts not listed in this manual) may be ordered either through a Southbend Authorized Parts Distributor or a Southbend Authorized Service Agency.

When ordering parts, please supply the Model Number, Serial Number, Part Number, and Part Description.

In case of problems in operation at initial installation, check type of gas and manifold pressure and compare with information listed on the serial plate.

## TROUBLESHOOTING FLOWCHARTS, PROCEDURES, AND WIRING DIAGRAMS

Find the symptom below that corresponds to the malfunction, then turn to the corresponding page. Follow the flowchart on that page until the problem is solved.

## NOTICE

This section contains troubleshooting flowcharts, procedures, and electric schematics to assist a qualified service technician in the servicing of Southbend cooking equipment. Information in the troubleshooting section is intended only as a guideline to isolate and test components. Before performing repair or ordering parts contact a Southbend Technical Service representative at 919-762-1000 option 2.

<b>Troubleshooting Flowchart, Procedure, or Wiring Diagram</b>	<b>Page</b>
Troubleshooting Oven	42
Troubleshooting Base Oven	43
Troubleshooting Oven Pilot	43
Flowchart of 120 Volt Electronic Ignition (Option)	44
Convection-Oven Blower Runs Intermittently	45
Convection-Oven Blower Does Not Run	46
Wiring Diagram for Oven Bases with Standing Pilot	47
Wiring Diagram for 120 Volt Oven Bases with Electronic Ignition	48
Wiring Diagram for 240 Volt Oven Bases with Electronic Ignition	49

## TROUBLESHOOTING OVEN

 **CAUTION**

Proper and efficient operation of oven is dependent on correct installation and function of components. Always verify that components are in place and functioning as intended.

The following table lists the possible causes of oven-related problems that may occur

Problem	Look for - 1
Oven will not come on.	<ul style="list-style-type: none"> <li>- Oven gas shut-off valve is OFF</li> <li>- Power switch is OFF</li> <li>- Problem with power switch</li> <li>- Problem with pilot solenoid</li> <li>- Problem with main gas solenoid</li> <li>- Problem with wiring</li> <li>- Problem with spark ignition module</li> <li>- Problem with flame sensor switch</li> </ul>
Oven pilot will not light	<ul style="list-style-type: none"> <li>- Oven gas shut-off valve is OFF</li> <li>- Problem with power switch</li> <li>- Problem with pilot solenoid</li> <li>- Problem with wiring</li> <li>- Problem with spark ignition module</li> </ul>
Convection blower motor will not run	<ul style="list-style-type: none"> <li>- Problem with fan speed switch</li> <li>- Problem with door switch</li> <li>- Problem with blower motor</li> <li>- Problem with wiring</li> </ul>
Oven will not maintain set temperature	<ul style="list-style-type: none"> <li>- Problem with oven thermostat</li> <li>- Problem with door switch</li> </ul>
Oven door too difficult to lift	<ul style="list-style-type: none"> <li>- Problem with door spring</li> <li>- Problem with door roller assembly</li> </ul>

## SERVICING CONVECTION OVEN BLOWER MOTOR

 **WARNING**

Before attempting to service or replace any electrical component, make sure that the power source has been disconnected.

 **CAUTION**

When changing motor or servicing unit, always verify that blower wheel rotation is clockwise when looking into the oven cavity.

The motor is serviceable from the front of the unit through the oven cavity.

Motor lubrication information can be found on the permanent label located on the motor.

If the blower does not run at all, consult the wiring diagrams in this manual (beginning Figure 16), or behind the oven kick plate.

If the blower runs intermittently, consult the following flowchart.

# TROUBLESHOOTING BASE OVEN



Proper and efficient operation of oven is dependent on correct installation and function of components. Always verify that components are in place and functioning as intended.

Consult the following table and the flowchart that begins on the following page.

Problem	Look for -
Oven will not come on.	– Oven pilot is out.
Oven pilot will not stay ignited	– Pilot gas not adjusted properly. – Bad thermopile. – Bad thermopile connections at safety valve. – Bad safety valve. – Clogged orifice. – Dirty pilot – Draft condition. – Improper ventilation system. – Air in gas line.

Figure 14

## Troubleshooting Oven Pilot

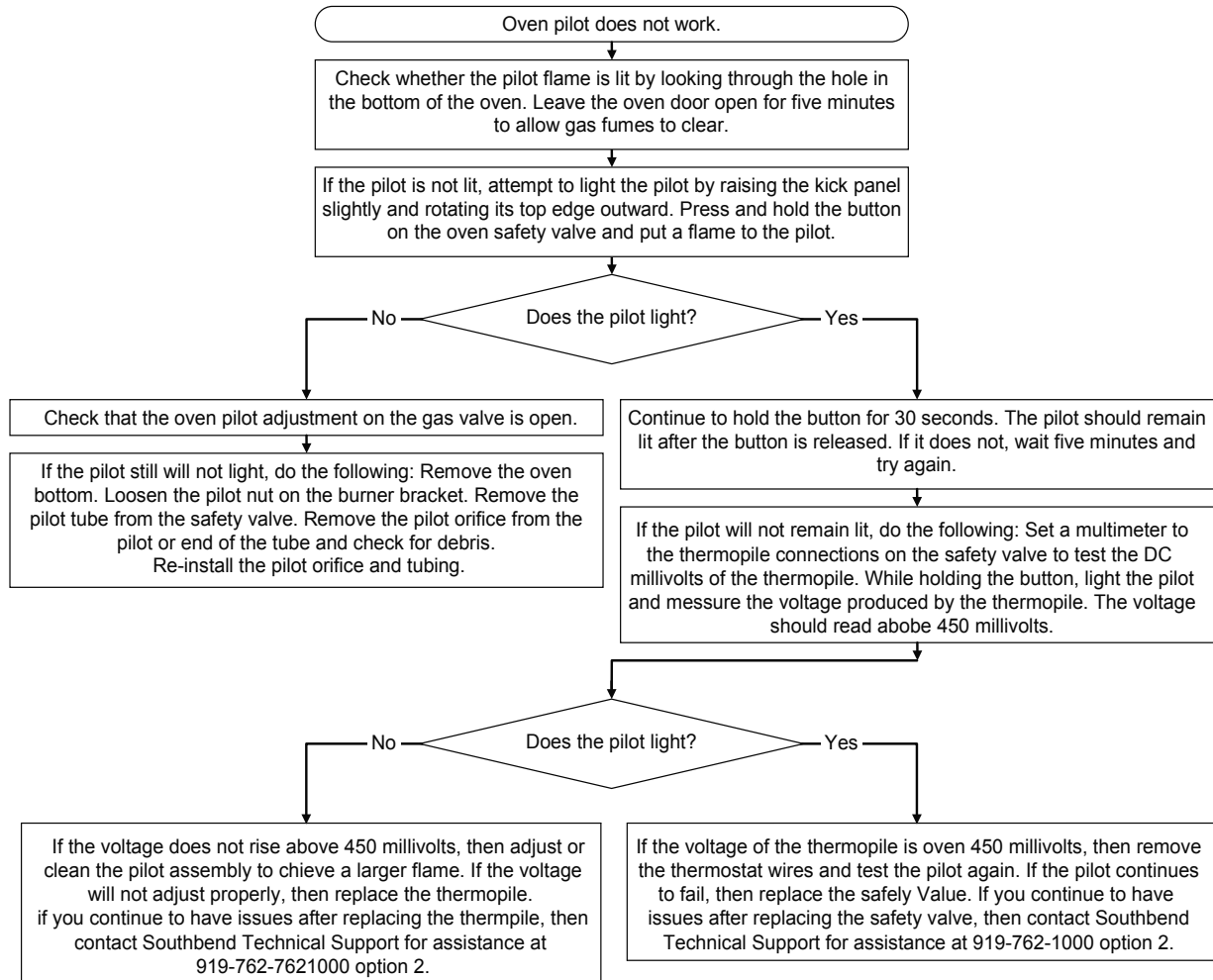
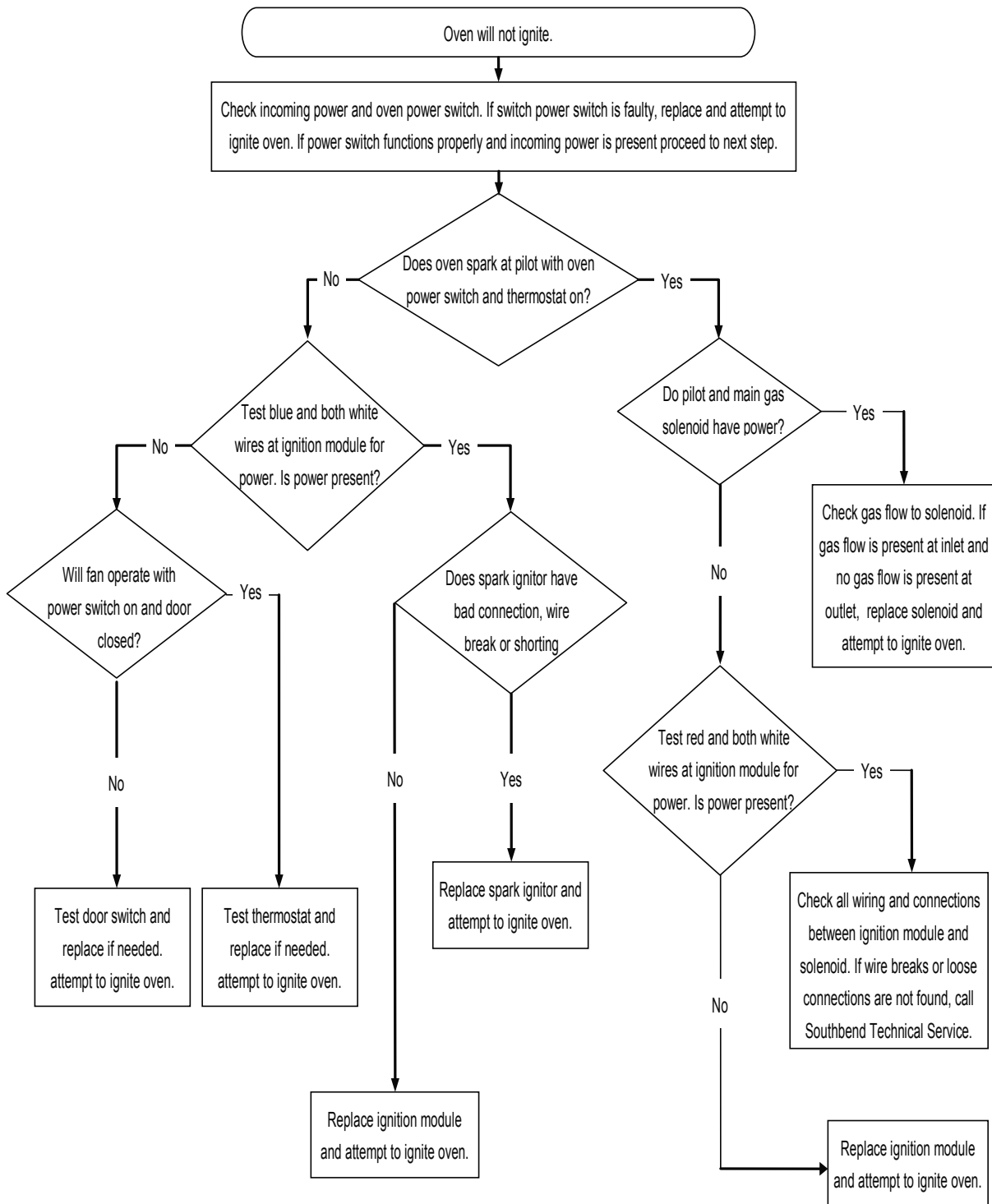

Figure 15

120 Volt Electronic Ignition (Option)



# TROUBLESHOOTING CONVECTION-OVEN BLOWER

## ⚠ WARNING

Before attempting to service or replace any electrical component, make sure power source has been disconnected.

## ⚠ CAUTION

When changing motor or servicing oven, always verify that blower wheel rotation is clockwise when looking into the oven cavity.

If the blower does not run at all, consult the flowchart that begins on the next page. If the blower runs intermittently, consult the flowchart on this page.

The appropriate wiring diagram for the oven can be found on the rear of the oven (as well as at the end of this section of this manual).

Figure 16

### Convection-Oven Blower Runs Intermittently

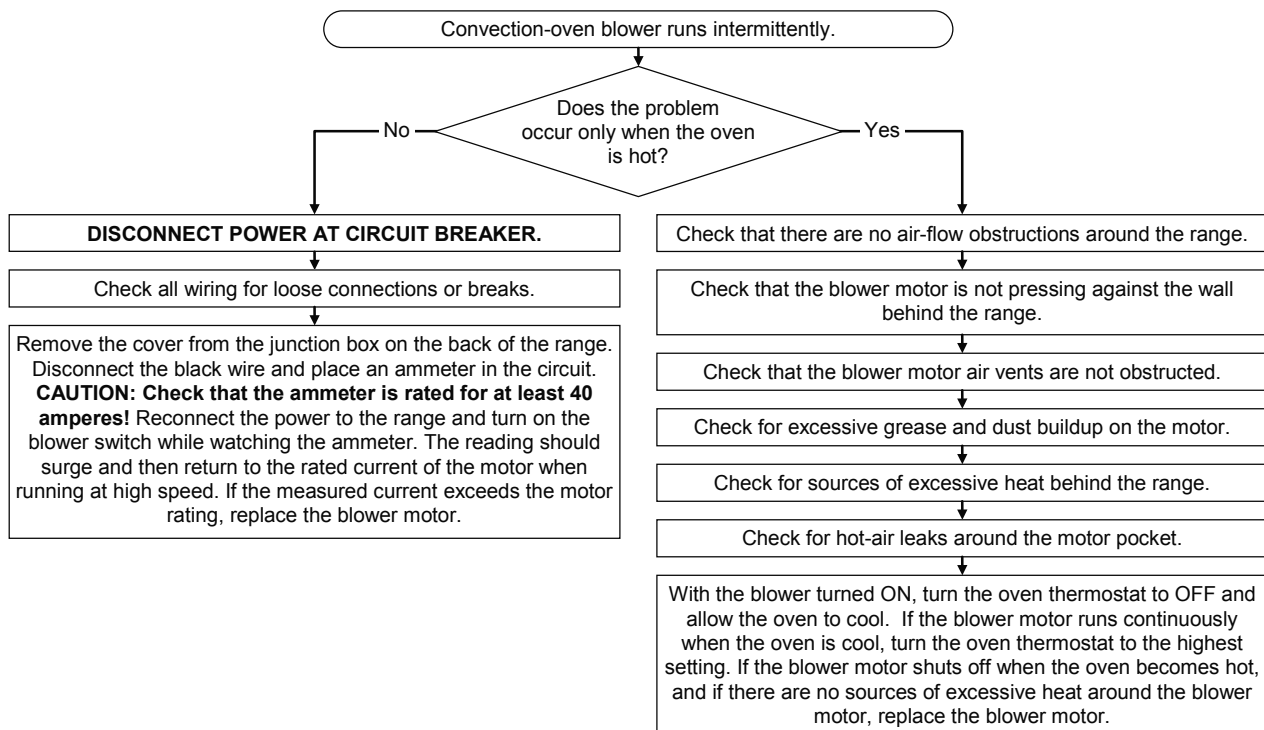

Figure 17

### Convection-Oven Blower Does Not Run

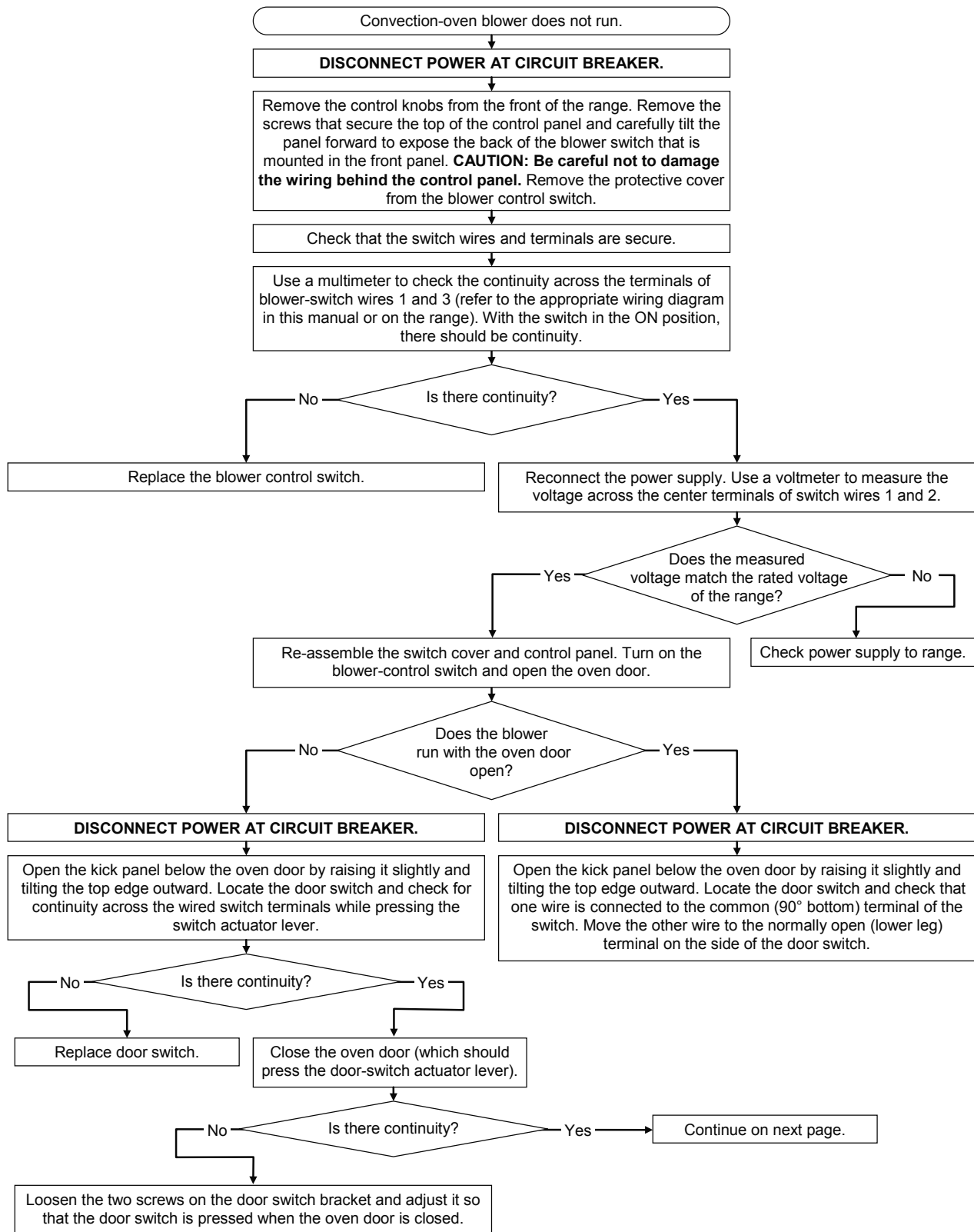

Figure 18

### Convection-Oven Blower Does Not Run, Continued

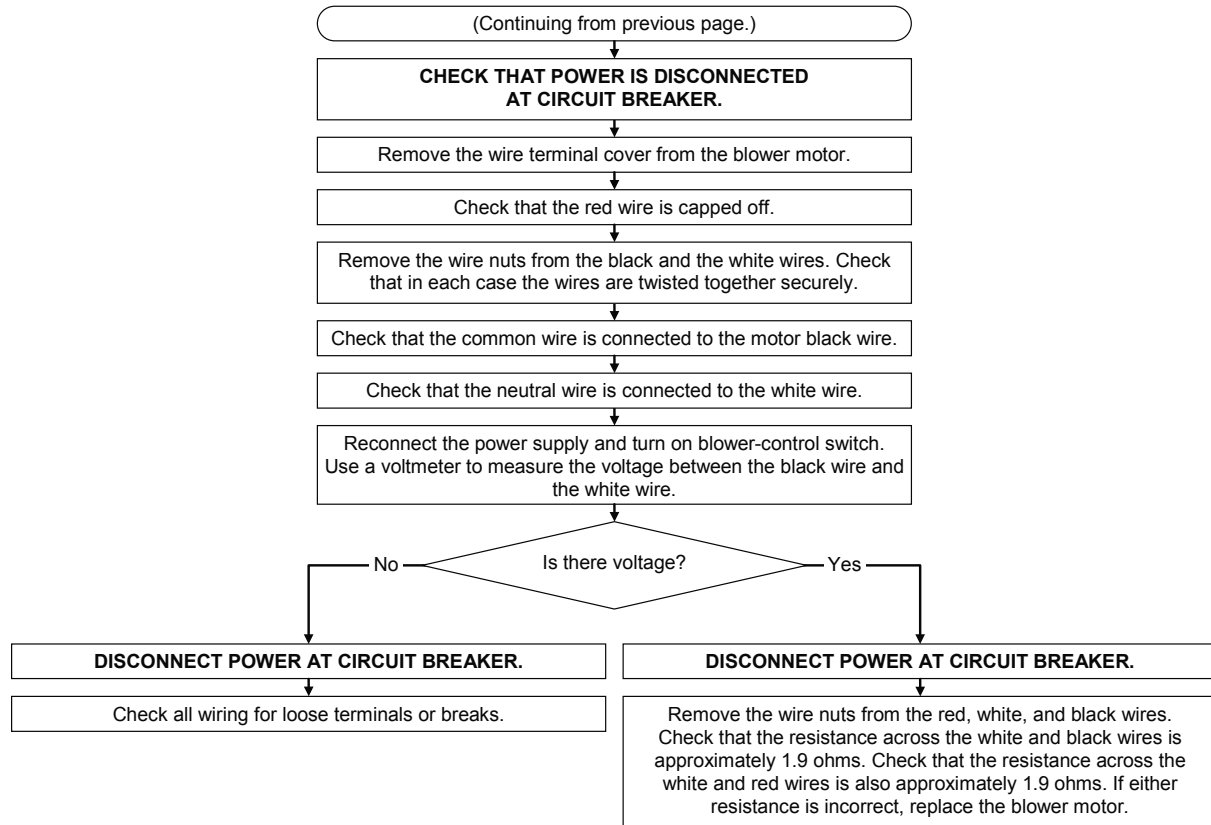
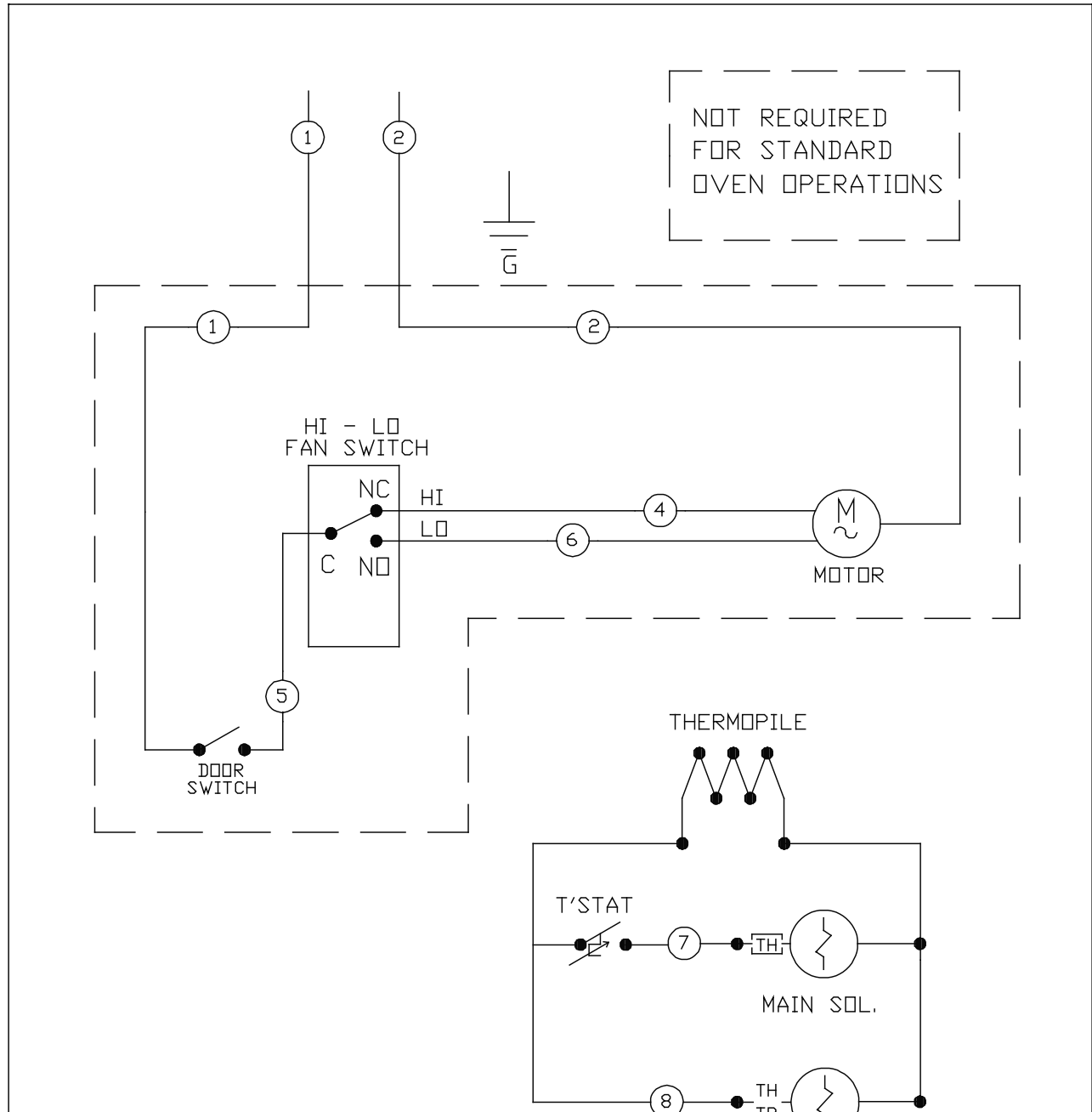

Figure 19

Wiring Diagram for Oven Bases with Standing Pilot



Legend	
○	WIRE NO'S
●	CONNECTIONS

VOLTAGE	110	120	220	240
PHASE	SINGLE	SINGLE	SINGLE	SINGLE
AMPERAGE	15	15	20	20
WIRING DIAGRAM 110/120 V & 220/240 V SECTIONAL RANGE				P/N 1189815

NOTICE: THIS WIRING DIAGRAM WAS CURRENT AS BUILT



Figure 20

### Wiring Diagram for 120 Volt Oven Bases with Electronic Ignition

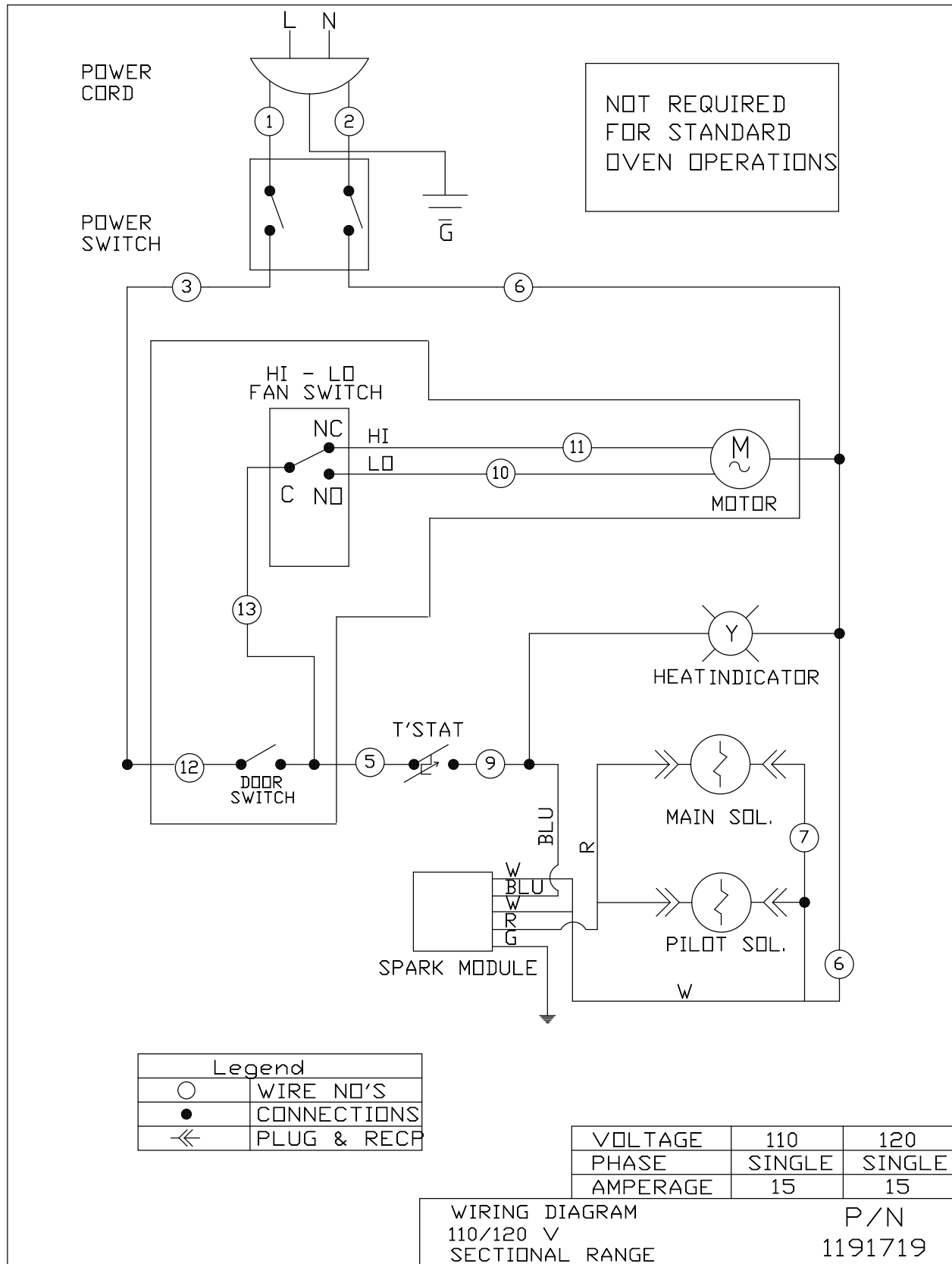
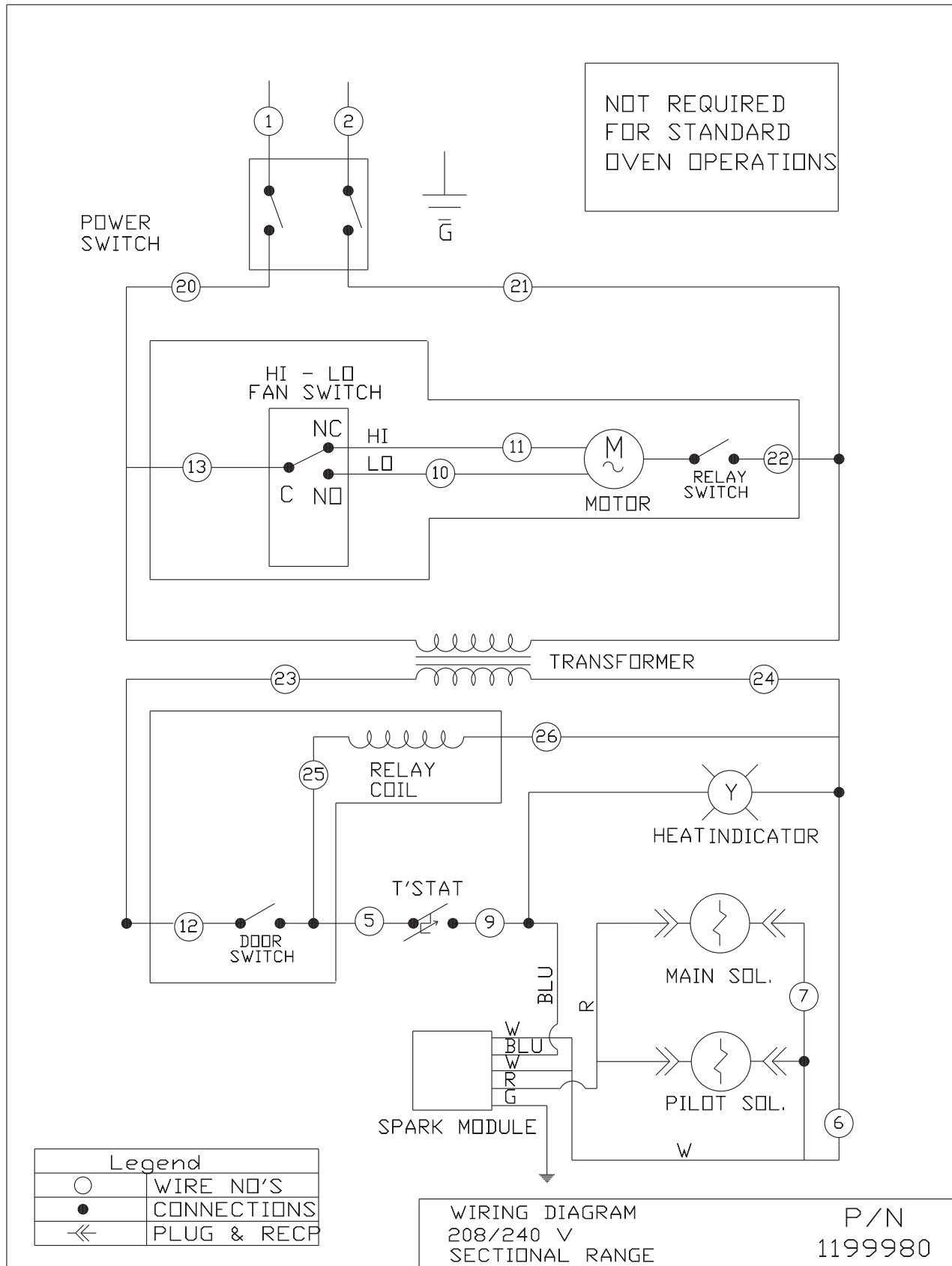

Figure 21

### Wiring Diagram for 240 Volt Oven Bases with Electronic Ignition



## PLATINUM SERIES RANGE

Notes:

## PLATINUM SERIES RANGE

Notes:

## PLATINUM SERIES RANGE

Notes:

# Platinum Series



A product with the Southbend name incorporates the best in durability and low maintenance. We all recognize, however, that replacement parts and occasional professional service may be necessary to extend the useful life of this appliance. When service is needed, contact a Southbend Authorized Service Agency, or your dealer. To avoid confusion, always refer to the model number, serial number, and type of your appliance.



Southbend  
1100 Old Honeycutt Road Fuquay-Varina, North Carolina 27526 USA  
[www.southbendnc.com](http://www.southbendnc.com)