



**IMPORTANT FOR FUTURE REFERENCE**  
Please complete this information and retain this manual for the life of the equipment:

Model #: \_\_\_\_\_

Serial #: \_\_\_\_\_

Date Purchased: \_\_\_\_\_

## Installation & Operation Manual

# Platinum Series Sectional Range

- Charbroiler Models
- Flush Open Burner Models
- Graduated Hot-Top Models
- Uniform Hot-Top Models
- Standard Griddle Models
- Step-Up Open-Burner Models
- Thermostatic Griddle Models
- Combination Open-Burner Hot-Top Models
- Combination Open-Burner Griddle Models
- Wood Smoker

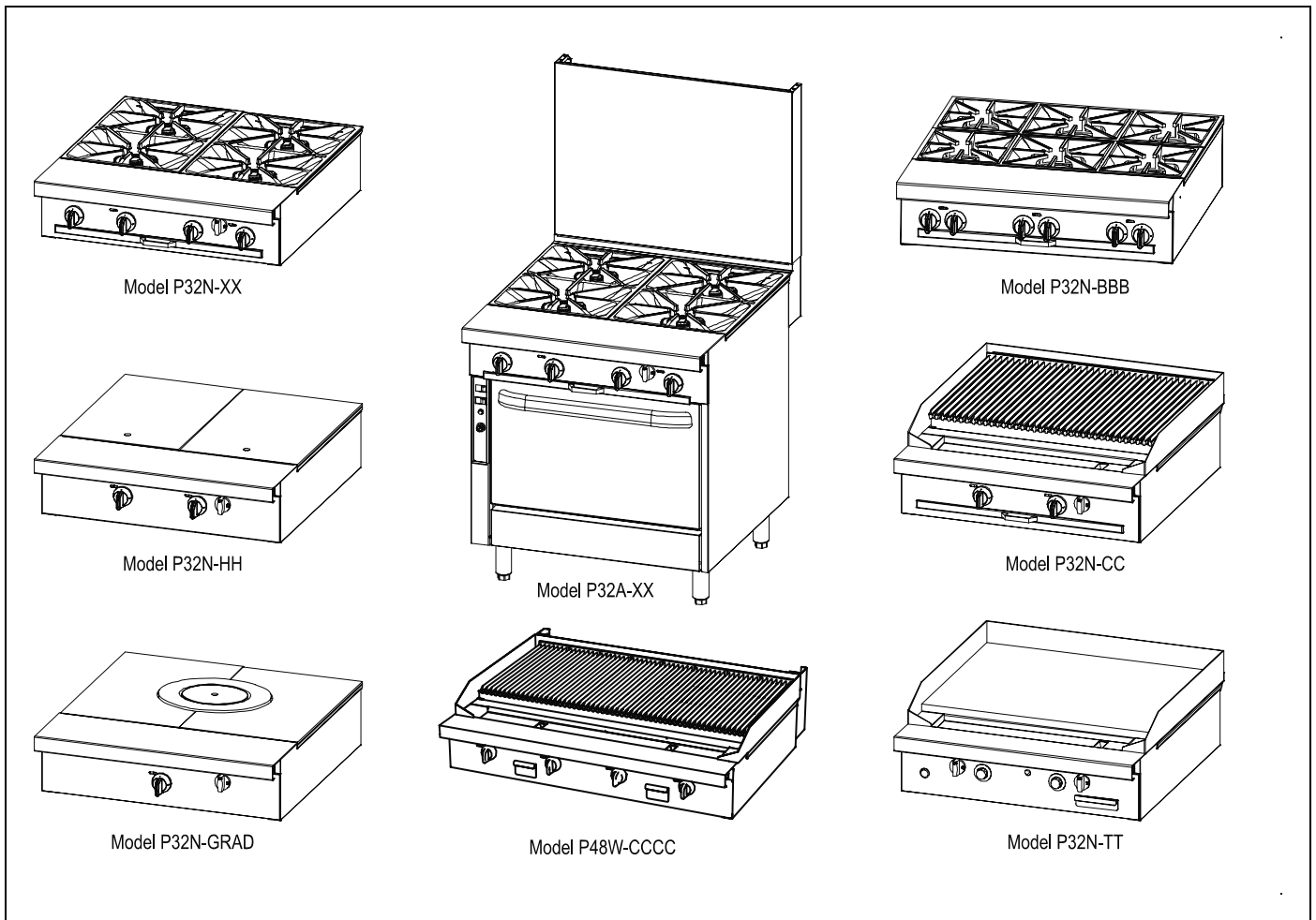

### **WARNING**

Improper installation, adjustment, alteration, service, or maintenance can cause property damage, injury, or death. Read installation, operation, and maintenance instructions thoroughly before installing or servicing this equipment.

1100 Old Honeycutt Road, Fuquay-Varina, NC 27526 USA • [www.southbendnc.com](http://www.southbendnc.com)



# SAFETY PRECAUTIONS

Before installing and operating this equipment, be sure everyone involved in its operation is fully trained and aware of precautions. Accidents and problems can be caused by failure to follow fundamental rules and precautions.

The following symbols, found throughout this manual, alert you to potentially dangerous conditions to the operator, service personnel, or to the equipment.



## DANGER

This symbol warns of immediate hazards that will result in severe injury or death.



## WARNING

This symbol refers to a potential hazard or unsafe practice that could result in injury or death.



## CAUTION

This symbol refers to a potential hazard or unsafe practice that could result in injury, product damage, or property damage.

## NOTICE

This symbol refers to information that needs special attention or must be fully understood, even though not dangerous.



## WARNING FIRE HAZARD FOR YOUR SAFETY

Do not store or use gasoline or other flammable vapors and liquids in the vicinity of cooking appliances.

Keep area around cooking appliances free and clear of combustibles.

Purchaser of equipment must post in a prominent location detailed instructions to be followed in the event the operator smells gas. Obtain the instructions from the local gas supplier.



## WARNING BURN HAZARD

Contact with hot surfaces will cause severe burns. Always use caution when operating cooking appliances.



## WARNING EXPLOSION AND ASPHYXIATION HAZARD

In the event a gas odor is detected, shut down equipment at the main gas shut-off valve and immediately call the emergency phone number of your gas supplier.

Improper ventilation can result in headaches, drowsiness, nausea, and could result in death. Do not obstruct the flow of combustion and ventilation air to and from cooking appliances.



## WARNING ELECTRIC SHOCK HAZARD

For appliances that use electric power, disconnect the power to the appliance before cleaning. Do not remove panels that require tools to remove.

## NOTICE

Southbend appliances are intended for commercial use only. Not for household use.

Warranty will be void if service work is performed by other than a qualified technician, or if other than genuine Southbend replacement parts are installed.

Give this Owner's Manual and important papers to the proper authority to retain for future reference.

# INTRODUCTION

Congratulations! You have purchased one of the finest pieces of heavy-duty commercial cooking equipment on the market.

You will find that your new equipment, like all Southbend equipment, has been designed and manufactured to meet the toughest standards in the industry. Each piece of Southbend equipment is carefully engineered and designs are verified through laboratory tests and field installations. With proper care and field maintenance, you will experience years of reliable, trouble-free operation. For best results, read this manual carefully.

**RETAIN THIS MANUAL FOR FUTURE REFERENCE.**

This manual is for Southbend Platinum Series Sectional Ranges.

This manual does NOT cover Southbend sectional fryers, fryer filter systems, salamander broilers, upright broilers, cheese melters, or refrigerated bases. Those appliances have their own manuals.

The location of the serial plate depends on the type of base (see Figure 1 below). On models with oven bases, the serial plate is located on the backside of the kick-plate below the oven door (lift the kick-plate straight up and tilt the top edge out and down.) On models with a cabinet base, the serial plate is located inside the left cabinet door. On modular (countertop) models, the serial plate is located inside the front valve panel.

Read these instructions carefully before attempting installation. Installation and initial startup should be performed by a qualified installer. Unless the installation instructions for this product are followed by a qualified service technician (a person experienced in and knowledgeable with the installation of commercial gas and/or electric cooking equipment) then the terms and conditions on the Manufacturer's Limited Warranty will be rendered void and no warranty of any kind shall apply.

In the event you have questions concerning the installation, use, care, or service of the product, write to:

Southbend  
1100 Old Honeycutt Road  
Fuquay-Varina, North Carolina 27526 USA

Figure 1

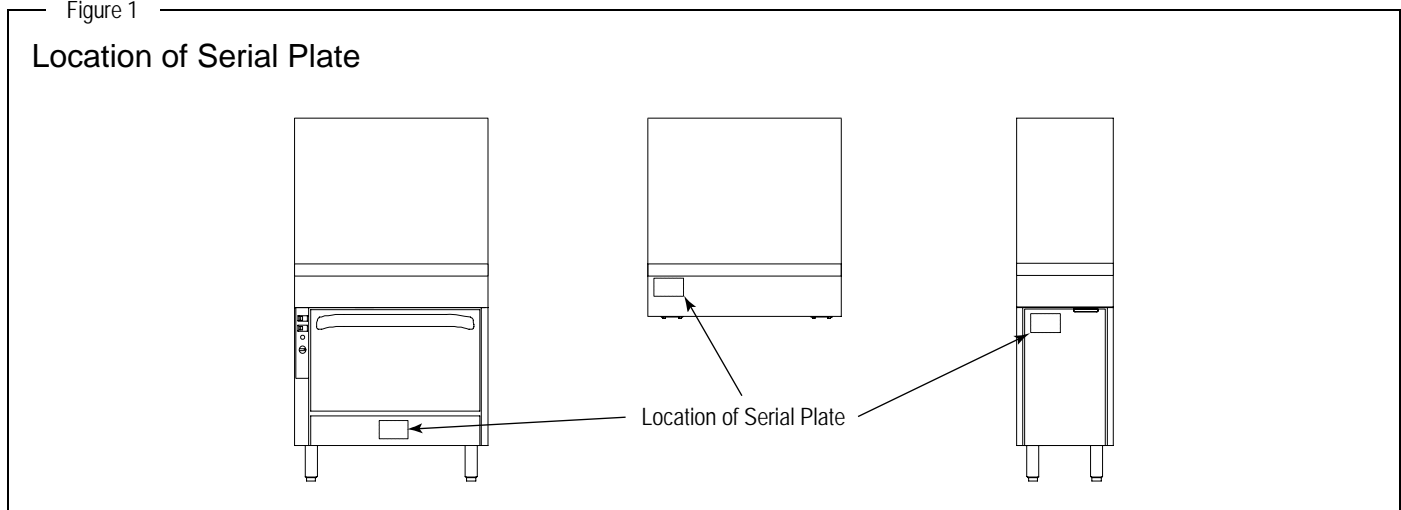

# SPECIFICATIONS

## NOTICE

Local codes regarding installation vary greatly from one area to another. The National Fire Protection Association, Inc., states in its NFPA 96 latest edition that local codes are the "authority having jurisdiction" when it comes to installation requirements for equipment. Therefore, installations should comply with all local codes.

Southbend reserves the right to change specifications and product design without notice. Such revisions do not entitle the buyer to corresponding changes, additions, or replacements for previously purchased equipment.

Southbend appliances are intended for commercial use only, not for household use.

The installation must conform with local codes, or in the absence of local codes, with the *National Fuel Gas Code, ANSI Z223.1, Natural Gas Installation Code, CAN/CGA-B149.1*, or the *Propane Installation Code CAN/CGA-B149.2*, as applicable, including:

1. The appliance and its individual shutoff valve must be disconnected from the gas supply piping system during any pressure testing of that system at test pressures in excess of 1/2 psi (3.45 kPa).
2. The appliance must be isolated from the gas supply piping system by closing its individual manual shutoff valve during any pressure testing of the gas supply piping system at test pressures equal to or less than 1/2 psi (3.45 kPa).

## CLEARANCES

### WARNING

#### MINIMUM CLEARANCES FROM COMBUSTIBLE CONSTRUCTION

There must be adequate clearance between the sectional range and combustible construction. Clearance must also be provided for servicing and for operation.

	Open-Top Standard-Burner Models	Open-Top PyroMax-Burner Models	Griddle Models	Uniform Hot-Top Models	Graduated Hot-Top Models
Sides	10"	13"	10"	10"	6"
Back	6"	6"	12"	12"	6"
Floor*	0"	0"	0"	0"	0"

#### Sectional Carbroilers and Sectional Wood Smokers are NOT recommended for installation next to combustible materials

\* Models with 6" legs or casters are suitable for installation on combustible floors.

Adequate clearance must be provided in the aisle in front of the unit to permit operation (including opening of doors and/or removal of grease drawers, drippings trays, and/or oven racks), as well as for servicing. No additional clearance is required for servicing as the sectional range is serviceable from the front.

Models with a convection-type oven require a minimum clearance of 2" between the motor on the back and non-combustible construction. Care must be taken to provide adequate air circulation to prevent the motor from overheating.

Minimum clearance from noncombustible construction is zero on the sides and back for all models (except for models with a convection-type oven).

The high-temperature flue products flow out through the top of the flue riser of all models, and from the top of open-top and charbroiler models. Installation under a vented hood is recommended.

Salamander broilers and cheese melters mounted on the flue riser of a sectional range may require additional minimum clearances (see the documentation for those appliances).

## VENTILATION

### **WARNING**

Improper ventilation can result in personal injury or death. Ventilation which fails to properly remove flue products can cause headaches, drowsiness, nausea, or could result in death.

All gas appliances must be installed in such a manner that the flow of combustion and ventilation air is not obstructed. Provisions for adequate air supply must be provided. Do not obstruct the area under the control panel or below the oven door (on the front), or the area below the flue riser (on the back) as combustion air enters through these areas.

### **NOTICE**

Proper ventilation is the owner's responsibility. Any problem due to improper ventilation will not be covered by the warranty.

Be sure to inspect and clean the ventilation system according to the ventilation equipment manufacturer's instructions.

Air for combustion enters from the front below the valve panel, as well as from the rear into the burner box. Ranges with solid tops (griddles and hot-tops) vent their flue products up the flue riser. On units with a base oven, combustion air enters from the front below the oven door. Oven flue products are vented up the flue riser.

Lack of sufficient ventilation will cause poor burner and pilot operating characteristics, resulting in inefficient performance. Such conditions also cause high ambient temperatures at the manifold area and create valve and thermostat problems.

If a ventilation canopy is used, it is recommended that the canopy extend 6" past the sectional range and that the bottom edge be located 6'6" from the floor. Filters should be installed at an angle of 45° or more from the horizontal. This position prevents dripping grease, and facilitates collecting the run-off grease in a drip pan under the filter.

A strong exhaust fan tends to create a vacuum in the room and may interfere with burner performance or may extinguish pilot flames. Fresh air openings approximately equal to the fan area will relieve such a vacuum. The exhaust fan should be installed at least 2" above the top of the flue riser.

If the sectional range is connected directly to an outside flue, a CSA design certified down draft diverter must be installed.

In case of unsatisfactory performance by any gas appliance, check the appliance with the exhaust fan turned OFF. Do this only long enough to check whether doing so corrects any problems with equipment performance. Then turn the exhaust fan back on and let it run to remove any exhaust that may have accumulated during the test.

## GAS SUPPLY

The sectional range is design-certified for operation on natural or propane gases. The sectional range is shipped configured and adjusted for the type of gas specified by the purchaser, which is indicated on the serial plate (see Figure 1 on page 3). Connect the sectional range **ONLY** to the type of gas for which it is configured and adjusted.

Each section has a 1-1/4" front gas manifold that can be coupled to adjacent section(s). Sections can be ordered with an optional 1" rear gas connection with a male NPT connector. Minimum supply pressure is 7" W.C. for natural gas, 11" W.C. for propane. An external pressure regulator and shut off valve must be provided. If using a flexible-hose gas connection, the I.D. of the hose must not be smaller than the connector on the unit and must comply with ANSI Z21.69. Provide an adequate means of restraint to prevent undue strain on the gas connection.

If applicable, the vent line from the gas appliance pressure regulator shall be installed to the outdoors in accordance with local codes, or in the absence of local codes, with the *National Fuel Gas Code, ANSI Z223.1, Natural Gas Installation Code, CAN/CGA-B149.1*, or the *Propane Installation Code CAN/CGA-B149.2*, as applicable.

An adequate gas supply is imperative. Undersized or low pressure lines will restrict the volume of gas required for satisfactory performance. Fluctuations of more than 25% on natural gas or 10% on propane gas will create problems and affect burner operating characteristics. A 1/8" pressure tap is located on the manifold to measure the manifold pressure. The supply line to the sectional range should be no smaller than the inside diameter of the pipe on the sectional range to which it is connected.

Figure 2

Dimensions

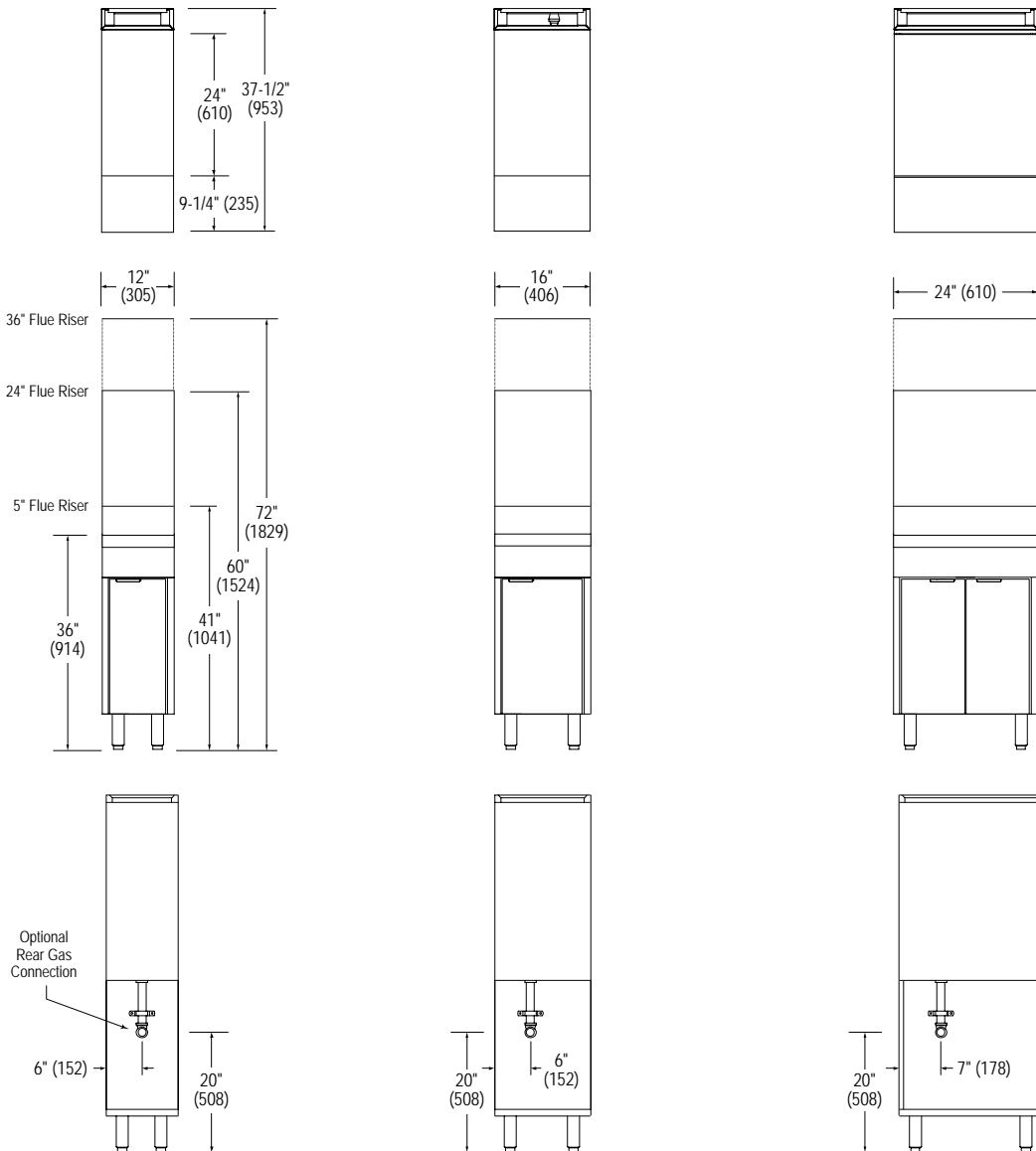
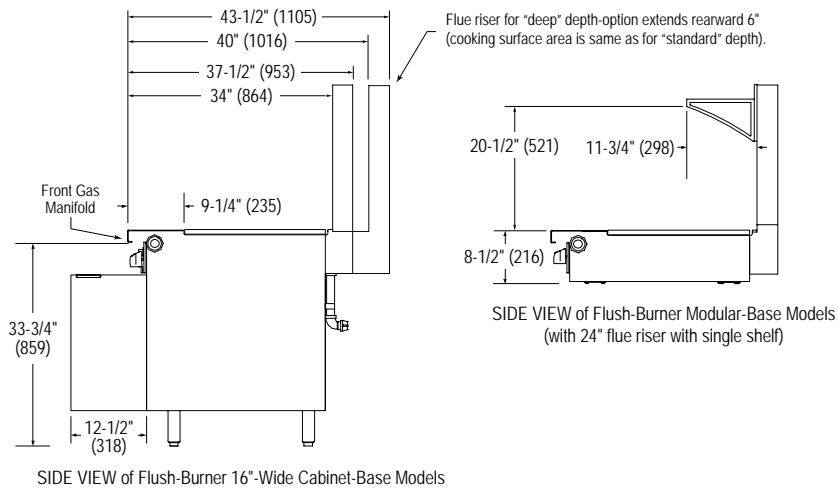
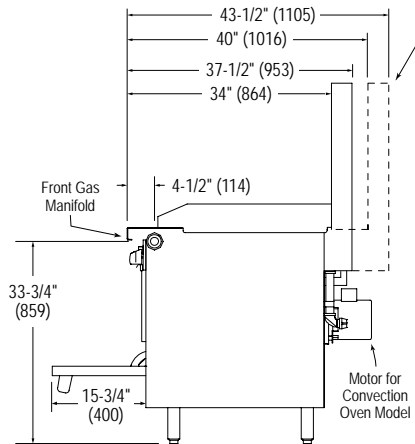

Figure 3

Dimensions (continued)



SIDE VIEW of Charbroiler/Griddle Oven-Base Models

Flue riser for "deep" depth-option extends rearward 6" (cooking surface area is same as for "standard" depth).

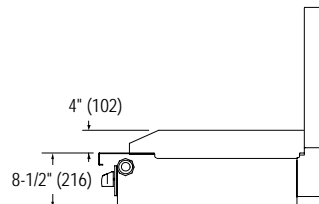

SIDE VIEW of Charbroiler/Griddle Modular-Base Models

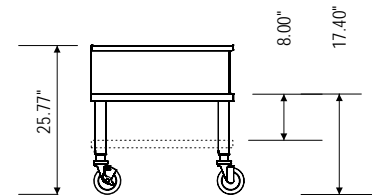

SIDE VIEW of Optional Equipment Stand

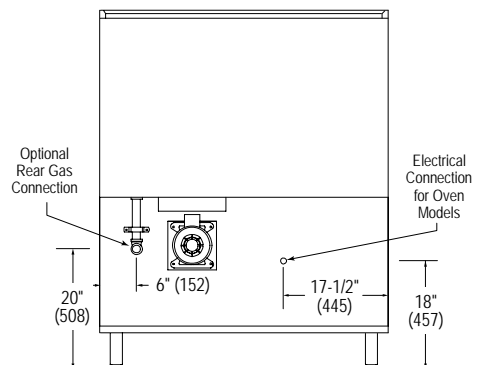
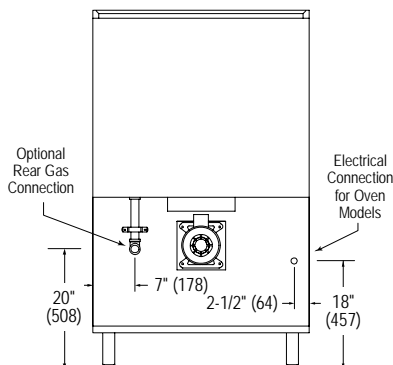
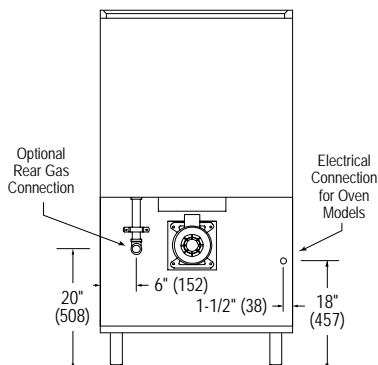
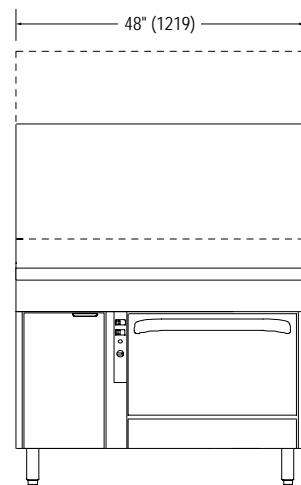
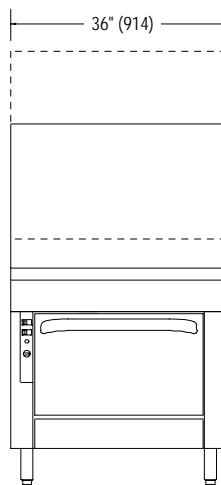
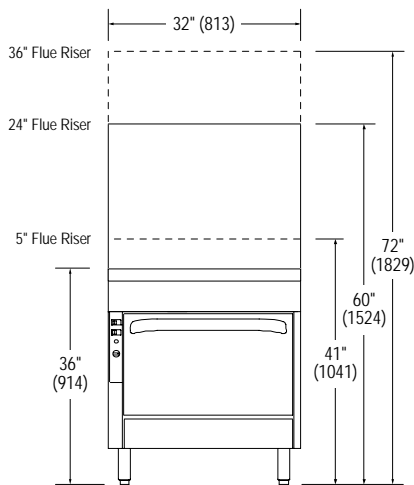
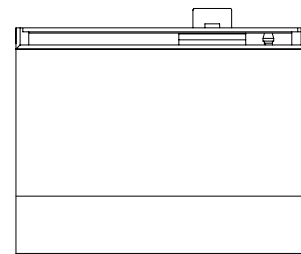
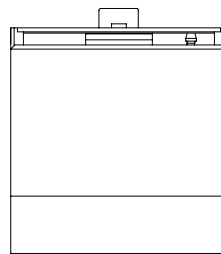
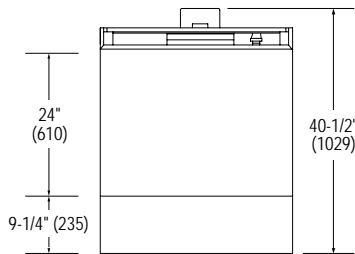

UTILITY REQUIREMENTS AND CRATED WEIGHT

Model	Width	Base Type	Top Type	GAS		ELECTRICITY		Crated Weight pounds (kg)
				Natural Gas (BTU/hour)	Propane (BTU/hour)	120V (amps)	208/240V (amps)	
P12C-B	12"	cabinet	2 flush open-burners	66,000	60,000	-	-	200 (91)
P12N-B	12"	modular	2 flush open-burners	66,000	60,000	-	-	130 (59)
P16C-C	16"	cabinet	charbroiler	40,000	36,000	-	-	220 (100)
P16C-G	16"	cabinet	standard griddle	40,000	36,000	-	-	270 (122)
P16C-H	16"	cabinet	uniform hot top	40,000	36,000	-	-	220 (100)
P16C-T	16"	cabinet	thermostatic griddle	40,000	36,000	-	-	270 (122)
P16C-X	16"	cabinet	2 flush PyroMax open-burners	90,000	84,000	-	-	220 (100)
P16N-C	16"	modular	charbroiler	40,000	36,000	-	-	150 (68)
P16N-G	16"	modular	standard griddle	40,000	36,000	-	-	240 (108)
P16N-H	16"	modular	uniform hot top	40,000	36,000	-	-	150 (68)
P16N-T	16"	modular	thermostatic griddle	40,000	36,000	-	-	240 (108)
P16N-X	16"	modular	2 flush PyroMax open-burners	90,000	84,000	-	-	150 (68)
P24C-CC	24"	cabinet	charbroiler	64,000	56,000	-	-	360 (163)
P24N-CC	24"	modular	charbroiler	64,000	56,000	-	-	360 (163)
P32A-BBB	32"	convection oven	6 flush open-burners	243,000	222,000	4.8	2.6	670 (305)
P32A-BBB-SU	32"	convection oven	6 open-burners (rear burners raised)	243,000	222,000	4.8	2.6	670 (305)
P32A-CC	32"	convection oven	charbroiler	125,000	114,000	4.8	2.6	670 (305)
P32A-GG	32"	convection oven	standard griddle	125,000	114,000	4.8	2.6	740 (336)
P32A-GRAD	32"	convection oven	graduated hot-top	107,000	87,000	4.8	2.6	670 (305)
P32A-HH	32"	convection oven	uniform hot top	125,000	114,000	4.8	2.6	670 (305)
P32A-TT	32"	convection oven	thermostatic griddle	125,000	114,000	4.8	2.6	740 (336)
P32A-XG	32"	convection oven	2 PyroMax open-burners (left side), standard griddle (right side)	175,000	168,000	4.8	2.6	705 (320)
P32A-XH	32"	convection oven	2 PyroMax open-burners (left side), uniform hot-top (right side)	175,000	168,000	4.8	2.6	670 (305)
P32A-XH-RE	32"	convection oven	2 PyroMax open-burners (front), uniform hot-top (rear)	175,000	168,000	4.8	2.6	670 (305)
P32A-XT	32"	convection oven	2 PyroMax open-burners (left side), thermostatic griddle (right side)	175,000	168,000	4.8	2.6	705 (320)
P32A-XX	32"	convection oven	4 PyroMax flush open-burners	225,000	200,000	4.8	2.6	670 (305)
P32C-BBB	32"	cabinet	6 flush open-burners	198,000	180,000	-	-	450 (205)
P32C-BBB-SU	32"	cabinet	6 open-burners (rear burners raised)	198,000	180,000	-	-	450 (205)
P32C-CC	32"	cabinet	charbroiler	80,000	72,000	-	-	450 (205)
P32C-GG	32"	cabinet	standard griddle	80,000	72,000	-	-	560 (255)
P32C-GRAD	32"	cabinet	graduated hot-top	62,000	45,000	-	-	490 (223)
P32C-HH	32"	cabinet	uniform hot top	80,000	72,000	-	-	490 (223)
P32C-TT	32"	cabinet	thermostatic griddle	80,000	72,000	-	-	560 (255)
P32C-XG	32"	cabinet	2 PyroMax open-burners (left side), standard griddle (right side)	130,000	126,000	-	-	525 (238)
P32C-XH	32"	cabinet	2 PyroMax open-burners (left side), uniform hot-top (right side)	130,000	126,000	-	-	490 (223)
P32C-XH-RE	32"	cabinet	2 PyroMax open-burners (front), uniform hot-top (rear)	124,000	120,000	-	-	490 (223)
P32C-XT	32"	cabinet	2 PyroMax open-burners (left side), thermostatic griddle (right side)	130,000	126,000	-	-	525 (238)
P32C-XX	32"	cabinet	4 PyroMax flush open-burners	180,000	168,000	-	-	490 (223)
P32D-BBB	32"	standard oven	6 flush open-burners	243,000	222,000	0*	0*	530 (241)
P32D-BBB-SU	32"	standard oven	6 open-burners (rear burners raised)	243,000	222,000	0*	0*	530 (241)
P32D-CC	32"	standard oven	charbroiler	125,000	114,000	0*	0*	530 (241)
P32D-GG	32"	standard oven	standard griddle	125,000	114,000	0*	0*	700 (318)
P32D-GRAD	32"	standard oven	graduated hot-top	107,000	87,000	0*	0*	630 (286)
P32D-HH	32"	standard oven	uniform hot top	125,000	114,000	0*	0*	630 (286)
P32D-TT	32"	standard oven	thermostatic griddle	125,000	114,000	0*	0*	700 (318)
P32D-XG	32"	standard oven	2 PyroMax open-burners (left side), standard griddle (right side)	175,000	168,000	0*	0*	665 (302)
P32D-XH	32"	standard oven	2 PyroMax open-burners (left side), uniform hot-top (right side)	175,000	168,000	0*	0*	630 (286)
P32D-XH-RE	32"	standard oven	2 PyroMax open-burners (front), uniform hot-top (rear)	169,000	165,000	0*	0*	630 (286)

table continues on next page



Model	Width	Base Type	Top Type	GAS		ELECTRICITY		Crated Weight pounds (kg)
				Natural Gas (BTU/hour)	Propane (BTU/hour)	120V (amps)	208/240V (amps)	
P32D-XT	32"	standard oven	2 PyroMax open-burners (left side), thermostatic griddle (right side)	175,000	168,000	0*	0*	665 (302)
P32D-XX	32"	standard oven	4 PyroMax flush open-burners	225,000	200,000	0*	0*	630 (286)
P32N-BBB	32"	modular	6 flush open-burners	198,000	180,000	-	-	260 (118)
P32N-BBB-SU	32"	modular	6 open-burners (rear burners raised)	198,000	180,000	-	-	260 (118)
P32N-CC	32"	modular	char broiler	80,000	72,000	-	-	260 (118)
P32N-GG	32"	modular	standard griddle	80,000	72,000	-	-	400 (182)
P32N-GRAD	32"	modular	graduated hot-top	62,000	45,000	-	-	315 (143)
P32N-HH	32"	modular	uniform hot top	80,000	72,000	-	-	315 (143)
P32N-TT	32"	modular	thermostatic griddle	80,000	72,000	-	-	400 (182)
P32N-XG	32"	modular	2 PyroMax open-burners (left side), standard griddle (right side)	130,000	126,000	-	-	358 (162)
P32N-XH	32"	modular	2 PyroMax open-burners (left side), uniform hot-top (right side)	130,000	126,000	-	-	315 (143)
P32N-XH-RE	32"	modular	2 PyroMax open-burners (front), uniform hot-top (rear)	124,000	120,000	-	-	315 (143)
P32N-XT	32"	modular	2 PyroMax open-burners (left side), thermostatic griddle (right side)	130,000	126,000	-	-	358 (162)
P32N-XX	32"	modular	4 PyroMax flush open-burners	180,000	168,000	-	-	315 (143)
P36A-BBB	36"	convection oven	6 flush open-burners	243,000	222,000	3.8	1.6	759 (344)
P36A-BBB-SU	36"	convection oven	6 open-burners (rear burners raised)	243,000	222,000	3.8	1.6	759 (344)
P36A-CCC	36"	convection oven	char broiler	141,000	126,000	3.8	1.6	621 (281)
P36A-GGG	36"	convection oven	standard griddle	141,000	126,000	3.8	1.6	654 (296)
P36A-GRAD	36"	convection oven	graduated hot-top	107,000	87,000	3.8	1.6	682 (303)
P36A-HHH	36"	convection oven	uniform hot top	141,000	126,000	3.8	1.6	682 (303)
P36A-TTT	36"	convection oven	thermostatic griddle	141,000	126,000	3.8	1.6	654 (297)
P36A-XX	36"	convection oven	4 PyroMax flush open-burners	225,000	210,000	3.8	1.6	670 (304)
P36C-BBB	36"	cabinet	6 flush open-burners	198,000	180,000	-	-	600 (272)
P36C-BBB-SU	36"	cabinet	6 open-burners (rear burners raised)	198,000	180,000	-	-	600 (272)
P36C-CCC	36"	cabinet	char broiler	128,000	112,000	-	-	462 (209)
P36C-GGG	36"	cabinet	standard griddle	96,000	84,000	-	-	495 (224)
P36C-GRAD	36"	cabinet	graduated hot-top	62,000	45,000	-	-	523 (237)
P36C-HHH	36"	cabinet	uniform hot top	96,000	84,000	-	-	523 (237)
P36C-TTT	36"	cabinet	thermostatic griddle	96,000	84,000	-	-	495 (224)
P36C-XX	36"	cabinet	4 PyroMax flush open-burners	180,000	168,000	-	-	490 (222)
P36D-BBB	36"	standard oven	6 flush open-burners	243,000	222,000	0*	0*	706 (320)
P36D-BBB-SU	36"	standard oven	6 open-burners (rear burners raised)	243,000	222,000	0*	0*	706 (320)
P36D-CCC	36"	standard oven	char broiler	141,000	126,000	0*	0*	568 (257)
P36D-GGG	36"	standard oven	standard griddle	141,000	126,000	0*	0*	601 (273)
P36D-GRAD	36"	standard oven	graduated hot-top	107,000	87,000	0*	0*	601 (273)
P36D-HHH	36"	standard oven	uniform hot top	141,000	126,000	0*	0*	629 (285)
P36D-TTT	36"	standard oven	thermostatic griddle	141,000	126,000	0*	0*	601 (273)
P36D-XX	36"	standard oven	4 PyroMax flush open-burners	225,000	210,000	0*	0*	630 (286)
P36N-BBB	36"	modular	6 flush open-burners	198,000	180,000	-	-	390 (177)
P36N-BBB-SU	36"	modular	6 open-burners (rear burners raised)	198,000	180,000	-	-	390 (177)
P36N-CCC	36"	modular	char broiler	96,000	84,000	-	-	276 (125)
P36N-GGG	36"	modular	standard griddle	96,000	84,000	-	-	375 (170)
P36N-GRAD	36"	modular	graduated hot-top	62,000	45,000	-	-	462 (209)
P36N-HHH	36"	modular	uniform hot top	96,000	84,000	-	-	346 (157)
P36N-TTT	36"	modular	thermostatic griddle	96,000	84,000	-	-	375 (170)
P36N-XX	36"	modular	4 PyroMax flush open-burners	180,000	168,000	-	-	568 (257)
P36W-CCC	36"	modular	wood smoker	96,000	84,000	-	-	330(150)
P48A-BBBB	48"	convection oven and cabinet	8 flush open burners	309,000	282,000	3.8	1.6	621 (281)
P48A-CCCC	48"	convection oven and cabinet	char broiler	165,000	150,000	3.8	1.6	621 (281)
P48A-GGG	48"	convection oven and cabinet	standard griddle	165,000	150,000	3.8	1.6	840 (378)
P48A-TTT	48"	convection oven and cabinet	thermostatic griddle	165,000	150,000	3.8	1.6	840 (378)
P48C-BBBB	48"	cabinets	8 flush open burners	264,000	240,000	-	-	462 (209)
P48C-CCCC	48"	cabinets	char broiler	120,000	108,000	-	-	462 (209)
P48C-GGG	48"	cabinets	standard griddle	120,000	108,000	-	-	660 (297)

Model	Width	Base Type	Top Type	GAS		ELECTRICITY		Crated Weight pounds (kg)
				Natural Gas (BTU/hour)	Propane (BTU/hour)	120V (amps)	208/240V (amps)	
P48C-TTT	48"	cabinets	thermostatic griddle	120,000	108,000	-	-	660 (297)
P48D-BBBB	48"	standard oven and cabinet	8 flush open burners	309,000	282,000	0*	0*	568 (257)
P48D-CCCC	48"	standard oven and cabinet	char broiler	165,000	150,000	0*	0*	568 (257)
P48D-GGG	48"	standard oven and cabinet	standard griddle	165,000	150,000	0*	0*	800 (360)
P48D-TTT	48"	standard oven and cabinet	thermostatic griddle	165,000	150,000	0*	0*	800 (360)
P48N-BBBB	48"	modular	8 flush open burners	264,000	240,000	-	-	276 (125)
P48N-CCCC	48"	modular	char broiler	120,000	108,000	-	-	276 (125)
P48N-GGG	48"	modular	standard griddle	120,000	108,000	-	-	500 (225)
P48N-TTT	48"	modular	thermostatic griddle	120,000	108,000	-	-	500 (225)
P48W-CCCC	48"	modular	wood smoker	128,000	112,000	-	-	363(1650)
P60W-CCCCC	60"	modular	wood smoker	160,000	140,000	-	-	596(270)
P72W-CCCCC	72"	modular	wood smoker	192,000	168,000	-	-	660(299)

**\*STANDING OVEN PILOT MODELS**

## ELECTRICITY SUPPLY

Units with convection-oven bases with optional electronic ignition require electric power (50Hz or 60Hz single-phase AC). 120V models have a 7-foot (2134 mm) power cord with a grounded plug (1.0 amps for "D" Models and 4.8 amps for "A" Models). The 208/240V models have a terminal block for connection to a single-phase 208/240V source (1.0 amps for "D" Models and 2.6 amps for the "A" Models).

The appliance, when installed, must be electrically grounded in accordance with local codes, or in the absence of local codes, with the *National Electrical Code, ANSI/NFPA 70*, or the *Canadian Electrical Code, CSA C22.2*, as applicable. An electrical diagram is located on the rear of the range, near the motor.

# OPERATION

 **DANGER**  
**EXPLOSION HAZARD**

In the event a gas odor is detected, shut down equipment at the main shut off valve. Immediately call the emergency phone number of your gas supplier.

 **CAUTION**

If a pilot flame pilot should go out, the flow of gas to the corresponding burner is NOT interrupted. Consequently, it is the responsibility of the operator to check the ignition of each burner immediately EVERY TIME a burner is turned on. Should ignition fail after 10 seconds, turn off the burner, wait 5 minutes, and then try again.

## LIGHTING AFTER GAS HAS BEEN SHUT OFF

When turning on the main gas supply to a sectional range, do the following:

1. Make sure that all the control knobs and power switches of all the connected appliances are in the OFF position.
2. Turn on the gas-supply shut-off valve(s).
3. Light the standing pilots of each connected appliance.
4. Light the ovens of the sectional range first, then wait six minutes before turning on the top sections. This enables all air to be purged from the sectional-range gas piping.

## SHUTDOWN OF ENTIRE RANGE

To place the range in a standby state (ready for use), Oven bases with the electronic ignition option, turn all burner control knobs to OFF, set all thermostats to their lowest position, and switch all ovens OFF. The pilots will remain lit. On the standing pilot units, same as above except turn thermostat knob to the "OFF" position. The pilots will remain lit.

To completely shut down the range for an extended period (or prior to disconnecting the gas supply), place the range in a standby state (as described in the previous paragraph), then turn OFF the manual shut-off valves of all gas supply connections. This will extinguish the pilots.

Figure 4

## Operation of Open-Burner Sections

Each 12"-wide or 16"-wide section has two control knobs. The left knob controls the rear burner, while the right knob controls the front burner. Each knob can be turned to OFF or to any position in the range from LOW to HIGH.

To start cooking, turn the appropriate control knob to HIGH. Visually check that the burner ignites. **The gas does NOT automatically shut off if the burner does not ignite!** If the burner does not ignite, check and/or light the pilots (see procedure at right). When the burner is hot, the burner flame should appear blue and steady (some slight yellowing of the flame tips may occur when using propane gas).

While cooking, do not allow excessive drippings and/or debris to accumulate on or below the burners. When necessary, pull out and clean the drippings tray.

When done cooking, turn the appropriate control knob to OFF. (The pilot should remain lit).

Each burner has a pilot located beside the burner. To light a pilot, do the following:

1. Check that the burner control knob is in the OFF position.
2. Check that the pilot is in the correct position beside the burner.
3. Turn on the gas supply to the sectional range (if not already on).
4. Light the pilot with a match or a pilot-lighting device. The pilot flame should be blue and steady.

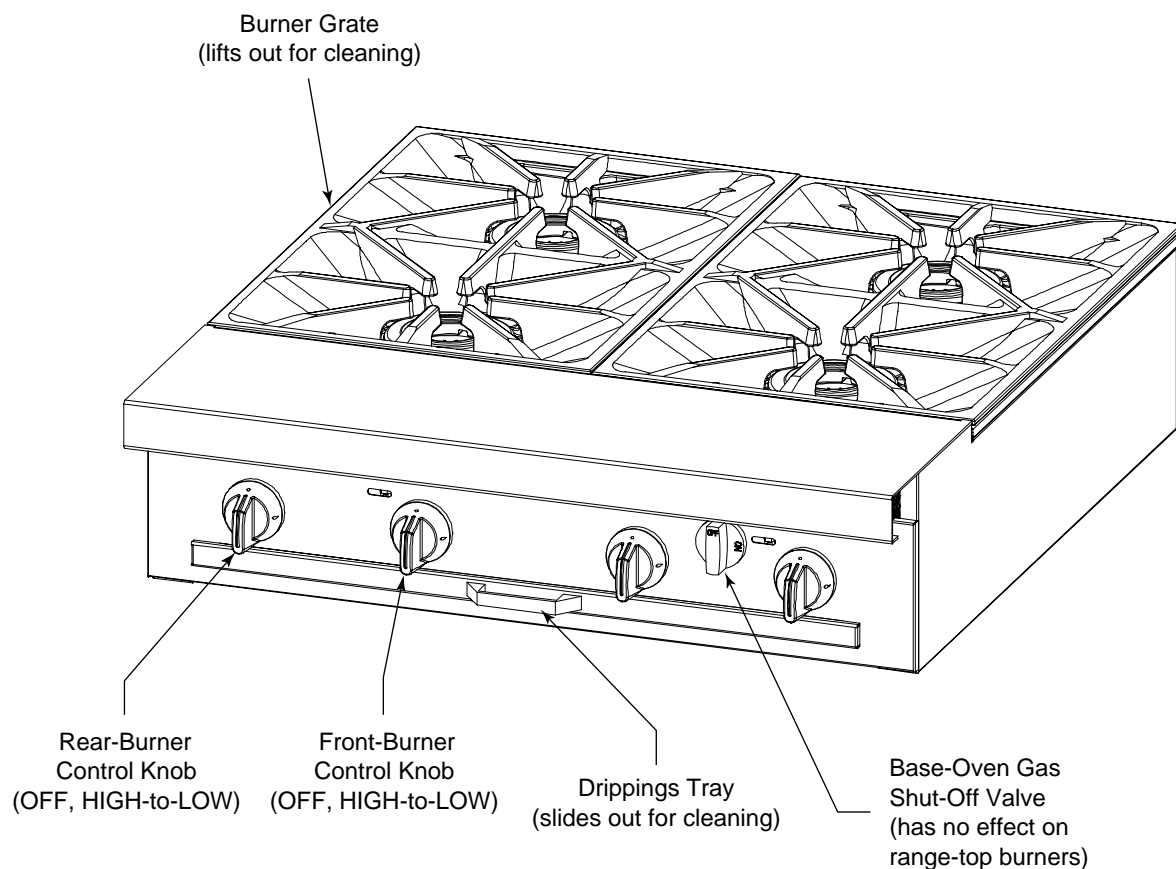

Figure 5

### Operation of Uniform Hot-Top Section

Each 16"-wide section has one control knob, which can be turned to OFF or to any position in the range from LOW to HIGH. When the control is set to HIGH, the hot top surface will heat to about 700°F (370°C).

To start cooking, turn the appropriate control knob to HIGH. Visually check that the burner ignites. **The gas does NOT automatically shut off if the burner does not ignite!** If the burner does not ignite, check and/or light the pilots (see procedure at right). When the burner is hot, the burner flame should appear blue and steady (some slight yellowing of the flame tips may occur when using propane gas).

Do not waste gas and abuse equipment by leaving the burner on HIGH all the time. During idling periods, turn the control to LOW to keep the top warm.

When done cooking, turn the appropriate control knob to OFF. (The pilot should remain lit).

Each 16"-wide section has two burners, each of which has a pilot located near the front of the burner. To light the pilots, do the following:

1. Check that the control knob is in the OFF position.
2. Lift up a hot-top section plate in order to expose the two pilots.
3. Check that each pilot is in the correct position.
4. Turn on the gas supply to the sectional range (if not already on).
5. Light the pilots with a match or a pilot-lighting device. The pilot flames should be blue and steady.

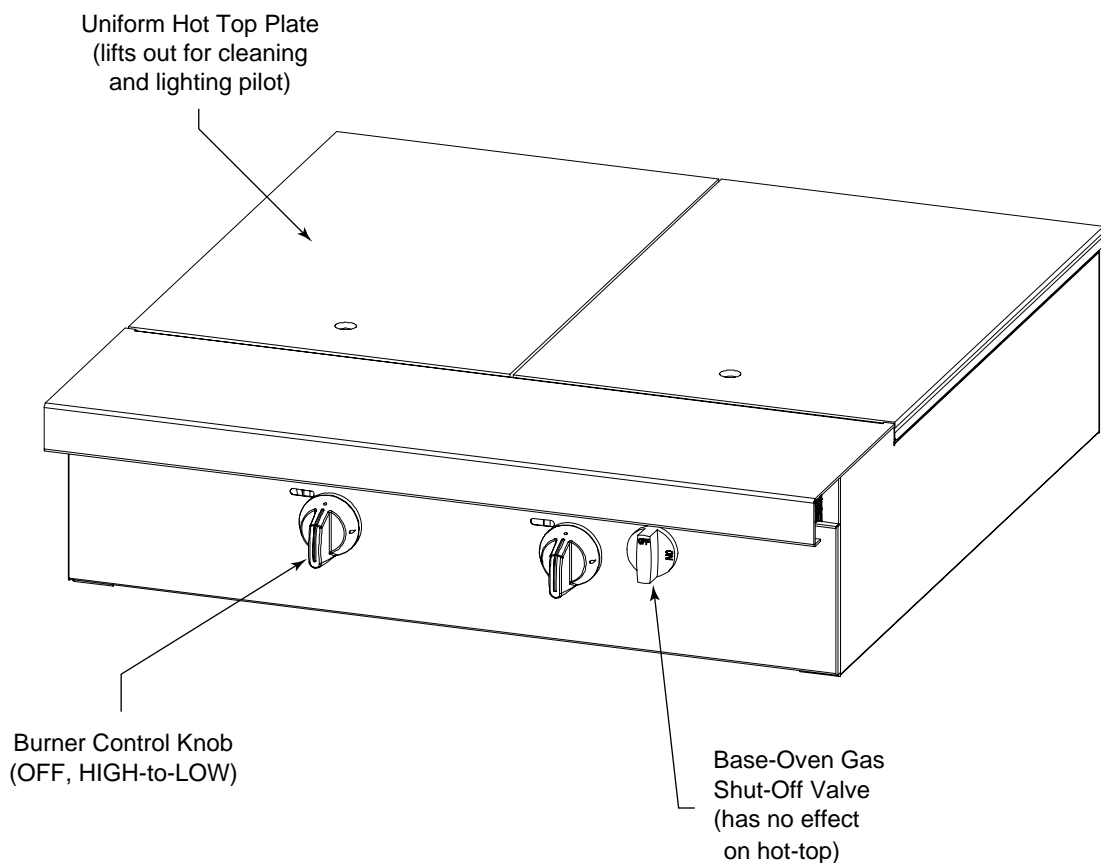

Figure 6

## Operation of Graduated Hot-Top Section

Each 32"-wide section has one control knob, which can be turned to OFF or to any position in the range from LOW to HIGH. When the control is set to HIGH, the round center section will heat to about 725°F (385°C), the ring-shaped section will heat to about 625°F (330°C), and the outer areas will heat to about 500°F (260°C).

To start cooking, turn the control knob to HIGH. Visually check that the burner ignites. **The gas does NOT automatically shut off if the burner does not ignite!** If the burner does not ignite, check and/or light the pilots (see procedure at right). When the burner is hot, the burner flame should appear blue and steady (some slight yellowing of the flame tips may occur when using propane gas).

Do not waste gas and abuse equipment by leaving the control on HIGH all the time. During idling periods, turn the control to LOW to keep the top warm.

When done cooking, turn the control knob to OFF. (The pilot should remain lit).

Each 32"-wide section has one burner. The pilot is located adjacent to the burner. To light the pilot, do the following:

1. Check that the control knob is in the OFF position.
2. Lift out the round center plate in order to expose the pilot.
3. Check that the pilot is in the correct position.
4. Turn on the gas supply to the sectional range (if not already on).
5. Light the pilot with a match or a pilot-lighting device. The pilot flame should be blue and steady.

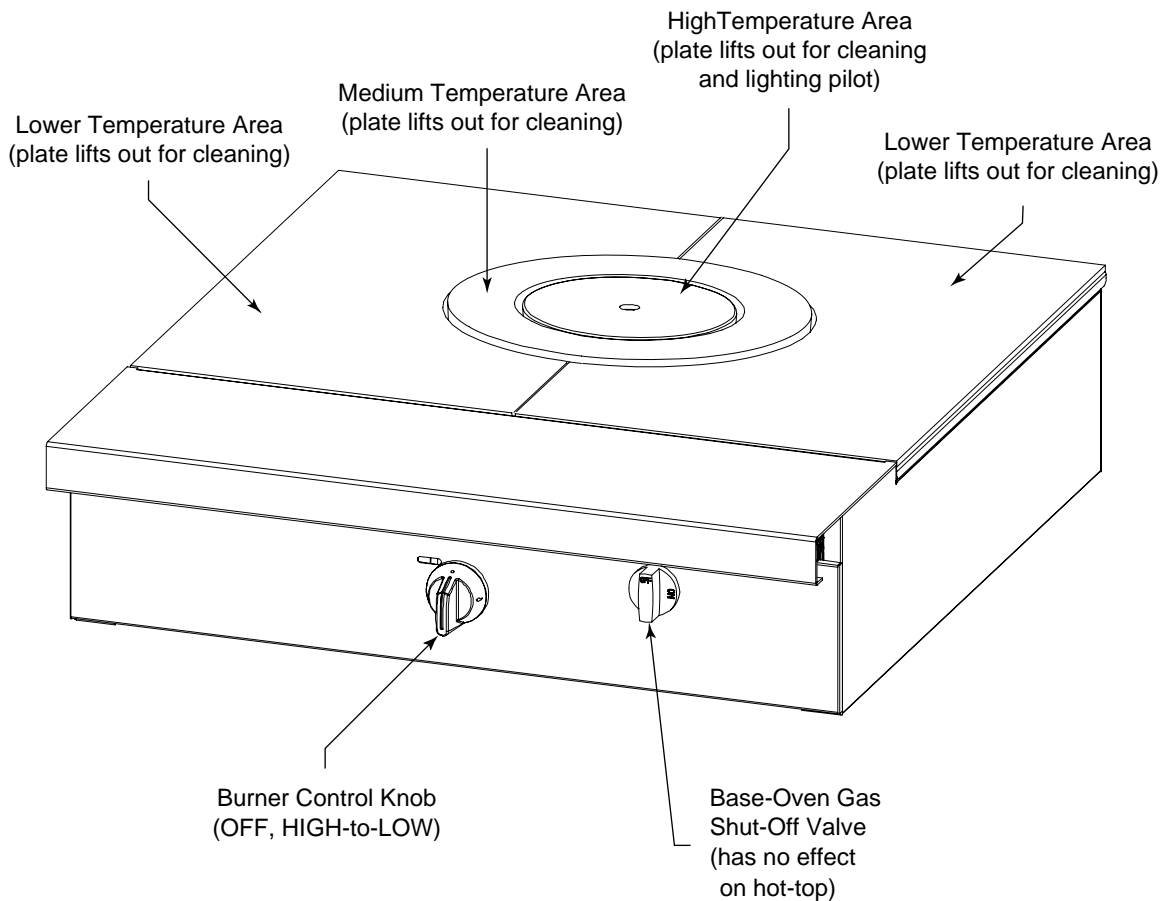

Figure 7

## Operation of Charbroiler Section

Each 12"-wide or 16"-wide section has one control knob, which can be turned to OFF, HIGH, or LOW. Each 6"-wide burner top-grate can be turned over to provide either wide branding marks or narrower branding marks with channels to carry away drippings (and so reduce flare up). The back-to-front slope of each top-grate is adjusted by positioning the back end of the top-grate on either the lower or the higher grate-support rail. The radiants (just above the burners) can be reversed front-and-back to provide higher heat toward the back than the front, or vice versa. "Lava rock" briquettes can be placed on grates located above the radiants.

To start cooking, turn the appropriate control knob to HIGH. Visually check that the burner ignites. **The gas does NOT automatically shut off if the burner does not ignite!** If the burner does not ignite, check and/or light the pilots (see procedure at right). When the burner is hot, the burner flame should appear blue and steady (some slight yellowing of the flame tips may occur when using propane gas).

When done cooking, turn the appropriate control knob to OFF. (The pilot should remain lit).

Each 12"-wide or 16"-wide section has two burners, each of which has a pilot located near the front of the burner. To light the pilots, do the following:

1. Check that the burner control knob is in the OFF position.
2. Lift up a grate in order to expose the two pilots. They are accessible through a slot near the front end of the radiant plate.
3. Check that each pilot is in the correct position.
4. Turn on the gas supply to the sectional range (if not already on).
5. Light the pilots with a match or a pilot-lighting device. The pilot flames should be blue and steady.

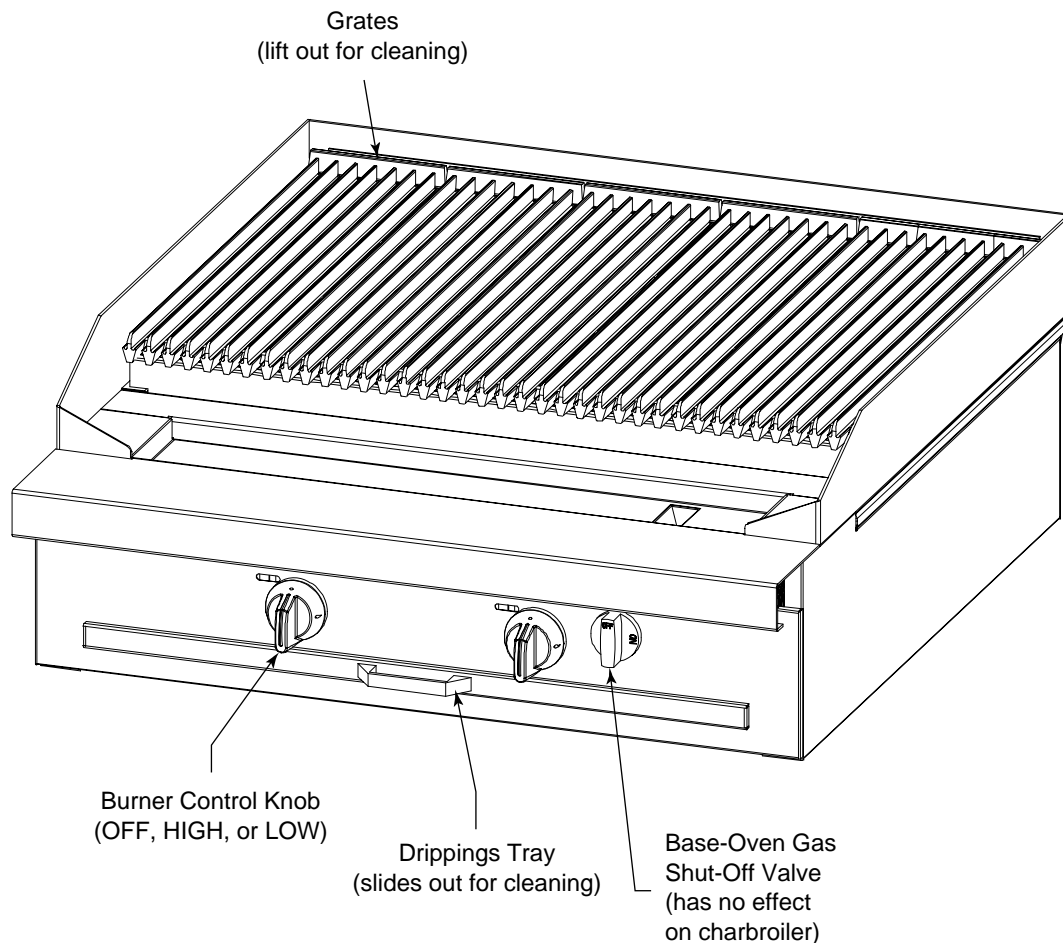

Figure 8

## Operation of Wood Smoker Section

### Wood Type(s): Split or Chunk Wood.

#### Wood Chunks:

Hickory Chunks, 10 lb bag, Southbend **P/N 1188495**  
 Mesquite Chunks, 10 lb bag Southbend **P/N 1188496**

#### Split Wood:

4" diameter X 20" long or smaller

#### Operation:

- Fill WATER/CATCH tray with water to bottom of wood grate.
- Place even layer of selected wood on wood grate inside smoker box.
- Turn control knobs to high position. Wood will then self ignite.  
 (Ignition time for wood in smoker will vary due to moisture content and type of wood used)

- Wood life can be extended by pre-soaking wood in water for a couple of hours prior to use.
- It is not recommended to soak wood overnight. Wood will become too saturated and delay ignition.
- Smoker box door should remain closed during normal operation.

#### Shutdown:

- Extinguish all remaining embers, or allow all wood to burnout.
- Place all remaining wood in a fire-safe container.
- Remove wood grate for cleaning.
- Remove Water/Catch tray and dispose of content in a fire-safe container.

#### WARNING / CAUTION

- Never use treated wood. When burned, treated wood can release pollutants harmful to your health into the air.

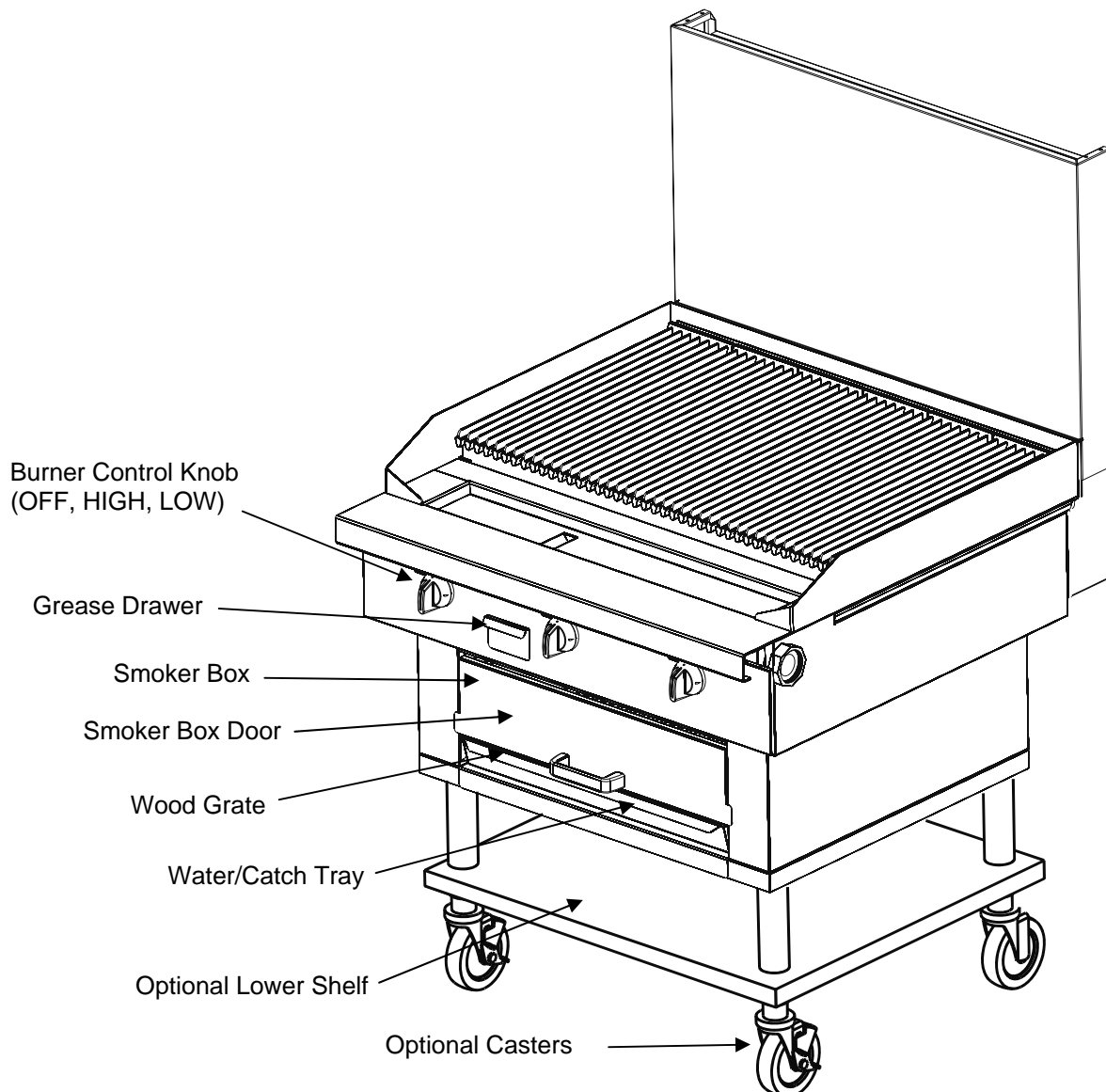



Figure 9

### Operation of Standard (Non-Thermostatic) Griddle Sections

Each 16"-wide section has one control knob, which can be turned to OFF, HIGH, or LOW.

To start cooking, turn the appropriate control knob to HIGH. Check that the burner ignites. **The gas does NOT automatically shut off if the burner does not ignite!** If the burner does not ignite, check and/or light the pilots (see procedure at right). When the burner is hot, the burner flame should appear blue and steady (some slight yellowing of the flame tips may occur when using propane gas).

Always remember to heat the griddle slowly because quick heating may cause costly damage. Never place utensils on the griddle.

Do not waste gas and abuse equipment by leaving the controls on HIGH all the time. During idling periods, turn the control to LOW to keep the griddle warm. (Do not allow the griddle to overheat above 550°F (288°C), as this will cause warping or breakage.)

When necessary while cooking, pull out and empty the grease drawer.

When done cooking, turn the appropriate control knob to OFF. (The pilot should remain lit).

Each 16" or 32" griddle section has a single pilot that is lit using a long match inserted through a hole in the front valve panel. (A 48"-wide griddle has two pilots.) To light the pilot, do the following:

1. Check that all the control knobs are in the OFF position.
2. Turn on the gas supply to the sectional range (if not already on).
3. Light the pilot by inserting a long match (at least 11" long) or pilot-lighting device straight into the hole on the front valve panel of the griddle.

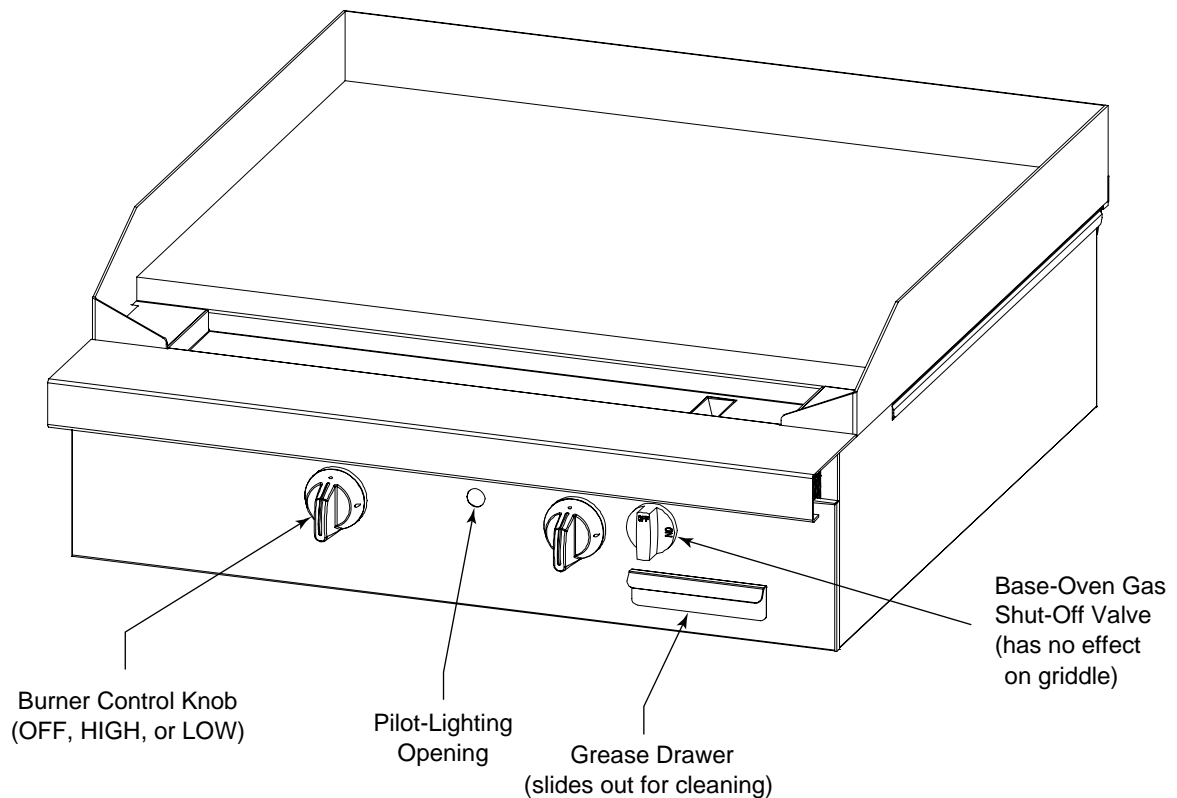

Figure 10

## Operation of Thermostatic Griddle Sections

Each 16"-wide section has one control knob that can be turned to OFF, or to any temperature in the range 150°F to 400°F (66°C to 204°C).

To start cooking, turn on the appropriate control knob. Check that the burner ignites. If the burner does not ignite, check and/or light the pilots (see procedure at right).

Never place utensils on the griddle.

Do not waste gas and abuse equipment by leaving the thermostat at a high temperature all the time. During idling periods, turn the thermostat to a low temperature to keep the griddle warm. (Do not allow the griddle to overheat above 550°F (288°C), as this will cause warping or breakage.)

When necessary while cooking, pull out and empty the grease drawer.

When done cooking, turn the appropriate control knob to OFF. (The pilot should remain lit).

Each 16" or 32" griddle section has a single pilot that is lit using a long match inserted through a hole in the front valve panel. (A 48"-wide griddle has two pilots.) To light the pilot, do the following:

1. Check that all control knobs are in the OFF position.
2. Turn on the gas supply to the sectional range (if not already on).
3. Turn on the Griddle Gas Shut-Off Valve (if not already on).
4. Press and hold in the Safety Switch Button.
5. Light the pilot by inserting a long match (at least 11" long) or pilot-lighting device straight into the hole on the front valve panel of the griddle.
6. After about a minute, release the Safety Switch Button. The pilot should remain lit.

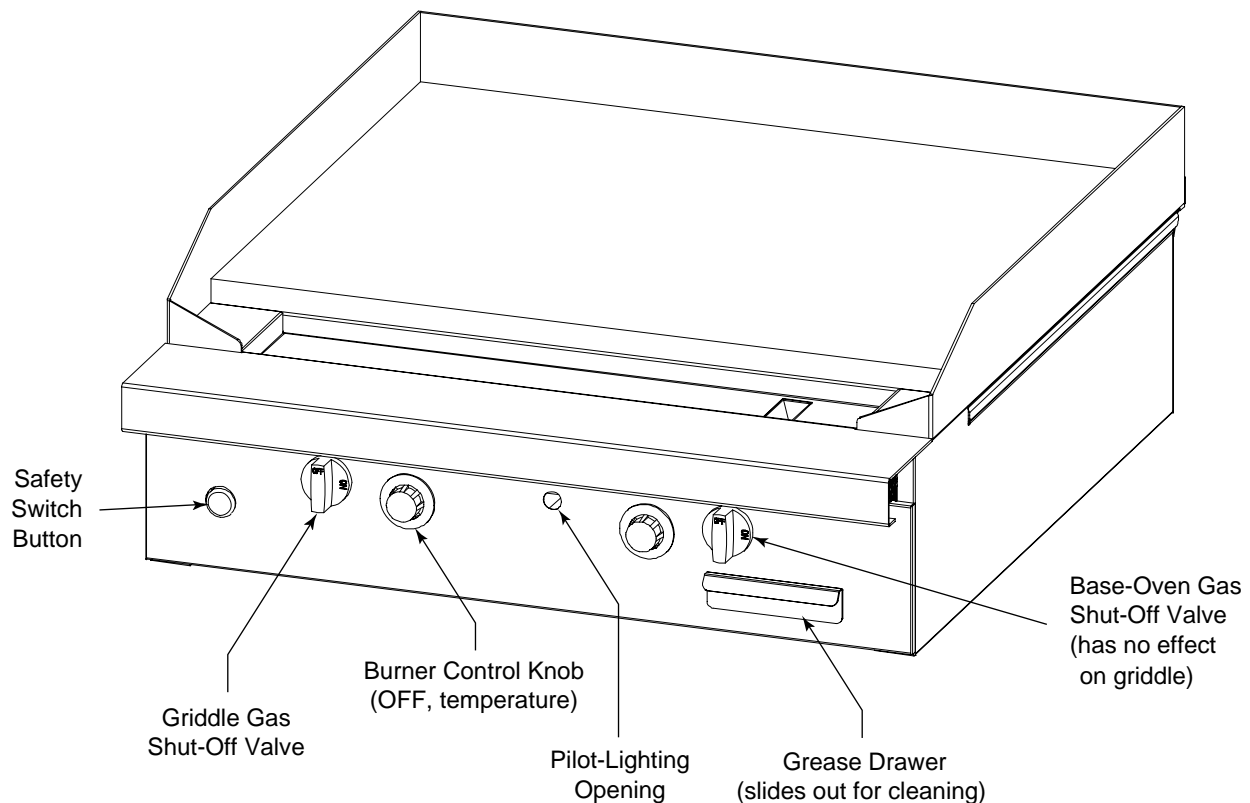

Figure 11

### Operation of Oven

Each oven has a thermostatic control that can be set in the range 175°F to 550°F (66°C to 260°C). Convection ovens have a fan that can be set to HI speed or LO speed.

For advice on using a convection oven, see the information on the following two pages of this manual.

While cooking, if the door is opened on a convection oven, the fan and heat will temporarily stop until the door is closed.

Do not allow excessive drippings and/or debris to accumulate on the interior of the oven. When necessary, pull out and clean the oven-bottom tray.

To light and start cooking, do the following:

#### FOR UNITS WITH A STANDING PILOT

1. Open kick panel and locate knob on valve assembly.
2. Turn the knob to PILOT and press inward. While holding the knob inward, light the pilot with an appropriate lighter.
3. Hold knob in the inward position for 30 seconds and release. The pilot should remain lit.
4. Turn the knob to ON and close kick panel.
5. Select on the thermostat the cooking temperature appropriate for the food to be cooked.
6. For convection ovens, select the fan speed appropriate for the food to be cooked.

#### FOR UNITS WITH ELECTRONIC IGNITION

1. Turn the Oven Gas Shut-Off Valve to ON.
2. Set the Oven Power Switch to ON. The pilot will light automatically. (You will hear a “snapping” sound until the pilot ignites.)
3. Select on the thermostat the cooking temperature appropriate for the food to be cooked.
4. For convection ovens, select the fan speed appropriate for the food to be cooked.
5. On units with a cooking light, the light will go out when the oven reaches the set temperature.

When done cooking, turn the Oven Power Switch to OFF and turn the Oven Gas Shut-Off Valve to OFF.

**Controls for Ovens with Standing Pilot**

**Controls for Ovens with Electronic Ignition**

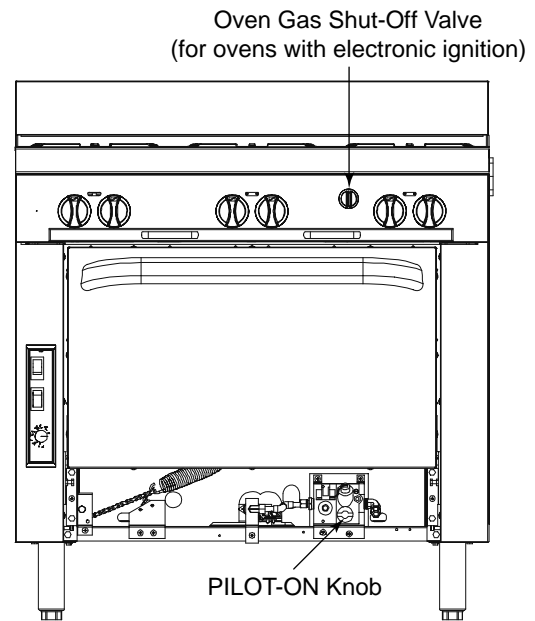
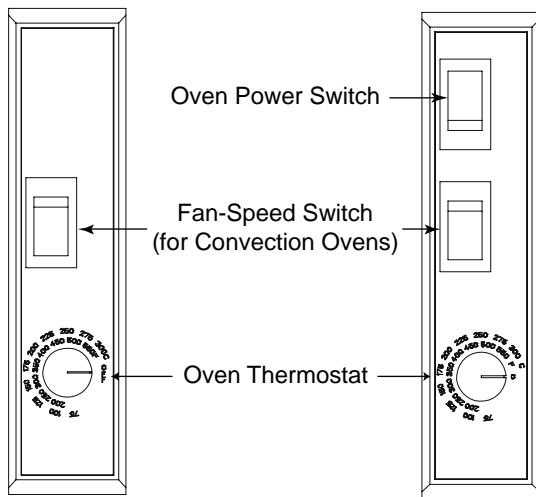

### **WARNING**

THE USE OF ALUMINUM FOIL CAN CAUSE HEAT DISTRIBUTION PROBLEMS IN OVENS. EXTREME CARE MUST BE USED WHEN PLACING ALUMINUM FOIL IN THE OVEN TO ENSURE THAT IT DOES NOT BLOCK OR CHANGE THE AIR FLOW. THE USE OF ALUMINUM FOIL MAY VOID THE PRODUCT WARRANTY IF ITS USE IS ASCERTAINED TO BE A PROBLEM.

## SUGGESTIONS FOR COOKING USING A CONVECTION OVEN

As a guide, set oven temperatures 25 to 50 degrees lower than called for in recipes using conventional (non-convection) ovens.

**FROZEN ENTREE PRODUCTS:** Punch holes in lid before heating. Tent lid if product has a tendency to stick, i.e., lasagna or macaroni and cheese. Use manufacturer's convection oven directions for time and temperature or reduce conventional oven temperature 50 degrees for a 6-1/2 size pan load. Some products may cook in 10 to 15 minutes less time than recommended for convection ovens if prepared from frozen in a 6 pan load.

Time and temperatures will vary depending upon load, mix, size of portion, and other factors. Use the following chart to develop your own cooking techniques:

Product	Timing (minutes)	Temperature Setting	Number of Racks Used	Count per Pan/Rack
Hamburger buns, 3 oz. - 4"	18	375°	3	24
Yeast rolls - 1 oz. Use temperature and time recommended by manufacturer for convection ovens for a 3 pan load.	10	400°	3	48
Fruit pies, 46 oz. frozen Use temperature and time from manufacturer's directions for convection ovens for a 12 pie load placed on 3 bun pans.	50	375°	3	4
Egg custard pies, 44 oz. frozen	60	325°	3	4
Dutch apple pies, 46 oz. frozen	50	350°	3	4
Baked potatoes, 8 oz. Wash and wrap in potato foil. Place 30 potatoes on 18 x 24 bun pan — 3 pans per load. Bake in 400°F oven for 1 hour.	60	400°	3	30 (wrapped)
Pre-blanch potatoes, frozen Spread on ungreased bun pans, 3 pans per load. Bake at 400°F, stirring once, for 15 to 18 minutes.	16	400°	3	5 lb.
Fish portions, pre-cooked, breaded, 3 oz. Use manufacturer's recommended temperature and time for convection oven for a 3 pan load.	16	400°	3	32
Macaroni & cheese, 6 lbs. - 40° temp.	45	400°	3	2-6 lbs.
Lasagna w/meat sauce, 6 lb. - 40° temp.	60	350°	3	2 - 6 lbs.
Lasagna w/meat sauce, 6 lb. - frozen	75	350°	3	2-6 lbs.
Salisbury steak w/gravy, 6 lb. - 40° temp.	45	400°	3	2-6 lbs.
Top round of beef No. 168				
14 lb. - rare	140° internal 14 min./lb.	250°	1	1 - 2
14 lb. - medium	150° internal 14 min./lb.	250°	1	1 - 2
14 lb. - well done	160° internal 14 min./lb.	250°	1	1 - 2

## CORRECTING PROBLEMS WHEN COOKING WITH A CONVECTION OVEN

If...	then...
Cakes are dark on the sides and not done in the center...	lower oven temperature.
Cake edges are too brown...	reduce number of pans or lower oven temperature.
Cakes have light outer color...	raise temperature.
Cake settles slightly in the center...	bake longer or raise oven temperature slightly. Do not open doors too often for long periods.
Pies have uneven color...	reduce number of pies per rack.
Meats are browned, but not done in center...	lower oven temperature and roast longer.
Meats are well done and not browned...	raise temperature. Limit amount of moisture.
Cakes ripple...	pans are overloaded or batter is too thin.
There is excessive meat shrinkage...	lower oven temperature.
Cakes are too coarse...	lower oven temperature.

# CLEANING & MAINTENANCE

## WARNING

Shut off the gas supply to the appliance before cleaning or performing maintenance on any gas appliance.

The appliance may be equipped with a restraint device to limit its movement in order to prevent damage to the gas connection. If disconnection of this restraint is necessary to move the appliance for cleaning or maintenance, reconnect the restraint when the appliance is moved back to its original installed position.

Southbend appliances are sturdily constructed of the best materials and are designed to provide durable service when treated with ordinary care. To expect the best performance, your equipment must be maintained in good condition and cleaned daily. Naturally, the periods for this care and cleaning depend on the amount and degree of usage.

*Following daily and periodic maintenance procedures will enhance long life for your equipment. Climatic conditions (such as salt air) may require more thorough and frequent cleaning or the life of the equipment could be adversely affected.*

Keep exposed, cleanable areas clean at all times.

## DAILY CLEANING AND MAINTENANCE

The daily cleaning procedure is as follows:

1. Shut off the main gas supply and allow the sectional range to cool.
2. Pull out, empty, and clean all drippings trays and grease drawers.
3. Remove and clean all oven racks and oven-bottom trays. Wipe clean the interior of the oven.
4. Visually check for any food and/or debris that may have fallen down into the burner areas.
5. Wipe clean all exterior surfaces.
6. Replace the cleaned and dried drippings trays, grease drawers, and oven components.
7. Check that nothing has been left on or near the sectional range that might block the entry of combustion air or the escape of combustion exhaust.

## MONTHLY CLEANING AND MAINTENANCE

The following tasks should be performed monthly:

1. Clean around burner air mixers and orifices if lint has accumulated in these areas.
2. Check for proper pilot operation. Check that the pilot flames are blue (with little or no yellow in the flame tips), stable (not lifting off the pilots), and not producing carbon. If adjustment is necessary, call for service.
3. Check for proper burner operation. The burner flames should be blue and stable. If adjustment is necessary, call for service.

## SEMIANNUAL CLEANING AND MAINTENANCE

At least twice a year the venting system should be examined and cleaned.

## STAINLESS-STEEL SURFACES

To remove normal dirt, grease and product residue from stainless steel surfaces that operate at LOW temperature, use ordinary soap and water (with or without detergent) applied with a sponge or cloth. Dry thoroughly with a clean cloth.

To remove BAKED-ON grease and food splatter, or condensed vapors; apply cleanser to a damp cloth or sponge and rub cleanser on the metal in the direction of the polishing lines on the metal. Rubbing cleanser, as gently as possible, in the direction of the polished lines will not mar the finish of the stainless steel. NEVER RUB WITH A CIRCULAR MOTION. Soil and burnt deposits which do not respond to the above procedure can usually be removed by rubbing the surface with SCOTCH-BRITE scouring pads or STAINLESS scouring pads. DO NOT USE ORDINARY STEEL

WOOL as any particles left on the surface will rust and further spoil the appearance of the finish. NEVER USE A WIRE BRUSH, STEEL SCOURING PADS (EXCEPT STAINLESS), SCRAPER, FILE OR OTHER STEEL TOOLS. Surfaces which are marred collect dirt more rapidly and become more difficult to clean. Marring also increases the possibility of corrosive attack. Refinishing may then be required.

“Heat tint” is darkened areas that sometimes appear on stainless steel surfaces where the area has been subjected to excessive heat. These darkened areas are caused by thickening of the protective surface of the stainless steel and are not harmful. Heat tint can normally be removed by the foregoing, but tint which does not respond to this procedure calls for a vigorous scouring in the direction of the polish lines using SCOTCH-BRITE scouring pads or a STAINLESS scouring pad in combination with a powered cleanser. Heat tint may be lessened by reducing heat to equipment during slack periods.

## BLACK BAKED-ENAMEL SURFACES

Allow appliance to cool somewhat after use and wash black baked-enamel surfaces with a hot, mild detergent or soap solution. In particular, clean off all grease deposits. Dry thoroughly with a dry cloth.

## OPEN-BURNERS AND GRATES

The grates can be removed and cleaned with a solution of hot water and strong soap or detergent. The burners themselves require little attention, but if spillage should occur, it may be necessary to clean around pilot areas, air mixer and under burners. Use a wire brush if necessary. Periodically, open-burners should be removed and cleaned. Allow the interior of the burner to drain, and dry thoroughly before replacing.

## HOT-TOP SURFACES

Before cleaning hot-top surfaces, allow them to cool. If water is used on hot-tops while they are still hot, they may crack, so avoid this practice. The hot-top plates can be removed and cleaned with hot water and detergent. A wire brush may be used on the underside of the hot top plate. It is recommended not to clean tops while still on the range, even if cooled, as excess water will drip into the burner box and deteriorate the metal.

## CARE OF GRIDDLES

A griddle should be carefully cared for in order to avoid possible damage. (The griddle should have been tempered as part of the installation procedure, see page 31). Use a Norton Alundum Griddle Brick to clean the griddle. Do not use any type of steel wool. Small particles may be left on the surface and get into food products. Do not clean spatula by hitting the edge on the griddle plate. Such action will only cut and pit the griddle plate, leaving it rough and hard to clean.

## OVEN INTERIOR

### **WARNING**

FOR YOUR SAFETY, DISCONNECT THE POWER SUPPLY TO THE SECTIONAL RANGE BEFORE CLEANING THE OVEN. WHEN CLEANING THE BLOWER WHEEL OF A CONVECTION OVEN, BE SURE TO HAVE THE POWER SWITCH IN THE “OFF” POSITION.

To clean the oven interior, first allow the oven to cool. Remove oven bottom and clean it by rubbing with strong detergent and a Brillo pad or similar scrubber. “Spillovers” should be cleaned from the bottom as soon as possible to prevent carbonizing and a “burnt-on” condition. For stubborn accumulations, commercial oven cleaners are recommended.

The porcelain oven door lining can be cleaned in a similar manner. The side, rear and top lining should be wiped only with a cloth dampened with a mild detergent and water. Avoid using excessive amounts of water, as this may drip into burner compartment and deteriorate the metal in that area. Do not use strong commercial cleaners or abrasive pads on the side, rear or top linings, as they may damage the finish or leave gray residue.

# INSTALLATION

## NOTICE

These installation procedures must be followed by qualified personnel or warranty will be void.

Local codes regarding installation vary greatly from one area to another. The National Fire Protection Association, Inc., states in its NFPA 96 latest edition that local codes are the “authority having jurisdiction” when it comes to installation requirements for equipment. Therefore, installations should comply with all local codes.

The installation must conform with local codes, or in the absence of local codes, with the *National Fuel Gas Code, ANSI Z223.1, Natural Gas Installation Code, CAN/CGA-B149.1*, or the *Propane Installation Code CAN/CGA-B149.2*, as applicable, including:

1. The appliance and its individual shutoff valve must be disconnected from the gas supply piping system during any pressure testing of that system at test pressures in excess of 1/2 psi (3.45 kPa).
2. The appliance must be isolated from the gas supply piping system by closing its individual manual shutoff valve during any pressure testing of the gas supply piping system at test pressures equal to or less than 1/2 psi (3.45 kPa).

## NOTICE

In the Commonwealth of Massachusetts all gas appliances vented by either mechanical systems or ventilation hoods shall comply with 248 CMR interlocking requirements.

This installation procedure does NOT cover Southbend sectional fryers, fryer filter systems, salamander broilers, upright broilers, cheese melters, or refrigerated bases. Consult the manuals of those appliances when they are being installed as part of a sectional range battery.

## STEP 1: UNPACKING

### IMMEDIATELY INSPECT FOR SHIPPING DAMAGE

All containers should be examined for damage before and during unloading. The freight carrier has assumed responsibility for its safe transit and delivery. If damaged equipment is received, either apparent or concealed, a claim must be made with the delivering carrier.

Apparent damage or loss must be noted on the freight bill at the time of delivery. The freight bill must then be signed by the carrier representative (Driver). If the bill is not signed, the carrier may refuse the claim. The carrier can supply the necessary forms.

A request for inspection must be made to the carrier within 15 days if there is concealed damage or loss that is not apparent until after the equipment is uncrated. The carrier should arrange an inspection. Be certain to hold all contents plus all packing material.

For each section, do the following:

1. Cut the banding straps and remove the corrugated cardboard surrounding the section. (If legs, casters, a flue riser, and/or shelf components were shipped in the same container, set them aside for installation in later steps of this procedure. Do not remove any tags or labels attached to the range until the range is installed and working properly.
2. Cut the banding strap holding the range to the wooden skid.
3. Unbolt the shipping hold-down brackets from the skid, then remove the brackets from the appliance (see Figure 12).
4. If the range is to be installed on 6" legs, go to Step 2a.  
If the range is to be installed on 6" casters, go to Step 2b.  
If the range is to be installed on a caster-frame, go to Step 2c.



Figure 12

### Removal of Shipping Hold-Down Brackets

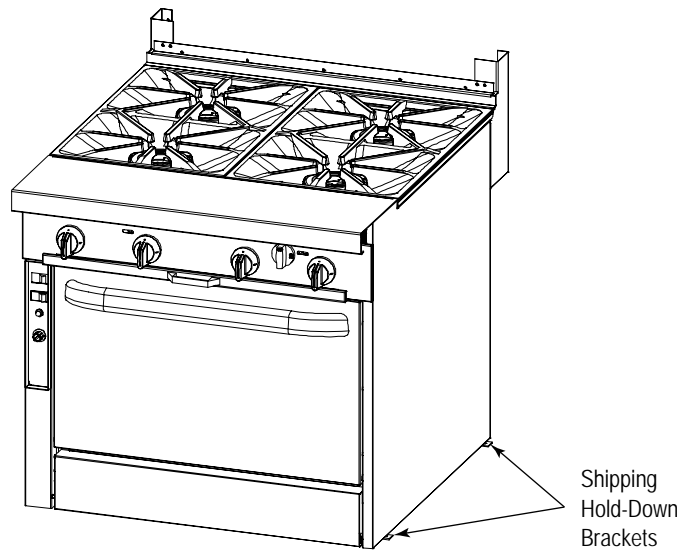

### STEP 2A: ATTACH LEGS TO THE RANGE

A set of four legs is packed with units ordered with legs. (For units ordered with casters, go to Step 2b.)

A threaded leg pad is fastened to the base frame at each corner. Each leg has a corresponding mating thread. The legs can be adjusted to overcome a slightly uneven floor.

6. Raise the range sufficiently to allow the legs to be attached. For safety, "shore up" and support the range with an adequate blocking arrangement strong enough to support the load.
7. Screw the legs into the holes in the centers of the leg pads (see Figure 13).
8. Lower the range gently onto a level surface. Never drop or allow the range to fall.
9. Go on to Installation Step 4.

Figure 13

### Installation of Legs

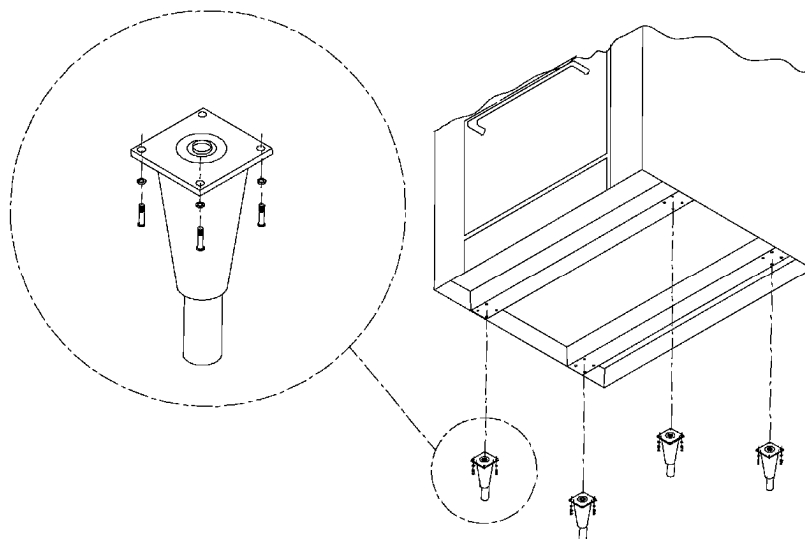

## STEP 2B: ATTACH CASTERS TO THE RANGE

### NOTICE

For an appliance equipped with casters, (1) the installation shall be made with a connector that complies with the *Standard for Connectors for Movable Gas Appliances, ANSI Z21.69* or *Connectors for Moveable Gas Appliances, CAN/CGA-6.16*, and a quick-disconnect device that complies with the *Standard for Quick-Disconnect Devices for Use With Gas Fuel, ANSI Z21.41*, or *Quick Disconnect Devices for Use with Gas Fuel, CAN1-6.9*, (2) adequate means must be provided to limit the movement of the appliance without depending on the connector and the quick-disconnect device or its associated piping to limit the appliance movement and (3) the restraining means should be attached to a frame member on the back of the unit.

A set of four casters is packed with units ordered with casters (instead of legs).

A threaded leg pad is fastened to the base frame at each corner. Each caster has a corresponding mating thread. The casters can be adjusted to overcome a slightly uneven floor. Casters are provided with a Zerk fitting for proper lubrication when required.

1. Raise unit sufficiently to allow the casters to be attached. For safety, "shore up" and support the range with an adequate blocking arrangement strong enough to support the load.
2. Screw the casters into the holes in the centers of the leg pads (see Figure 14). Install the casters that have a locking brake under the front of the range.
3. Lower the range gently onto a level surface. Never drop or allow the range to fall.
4. Go to Installation Step 3.

Figure 14

### Installation of Casters

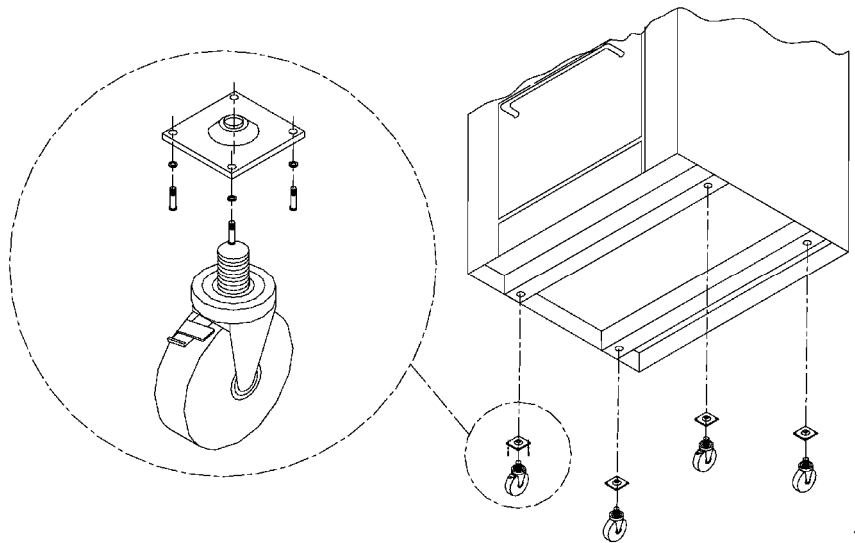

1

## STEP 2C: MOUNT RANGE ON CASTER FRAME

### NOTICE

For an appliance equipped with casters, (1) the installation shall be made with a connector that complies with the *Standard for Connectors for Movable Gas Appliances, ANSI Z21.69* or *Connectors for Moveable Gas Appliances, CAN/CGA-6.16*, and a quick-disconnect device that complies with the *Standard for Quick-Disconnect Devices for Use With Gas Fuel, ANSI Z21.41*, or *Quick Disconnect Devices for Use with Gas Fuel, CAN1-6.9*, (2) adequate means must be provided to limit the movement of the appliance without depending on the connector and the quick-disconnect device or its associated piping to limit the appliance movement and (3) the restraining means should be attached to a frame member on the back of the unit.

The range can be mounted on an optional caster frame. The frame will have a threaded leg pad at each corner. Each caster has a corresponding mating thread. The casters can be adjusted to overcome a slightly uneven floor. Casters are provided with a Zerk fitting for proper lubrication when required.

1. Assemble the caster frame components.
2. Screw the casters into the holes in the centers of the leg pads of the caster frame. Install the casters that have a locking brake under the front of the battery.
3. Lower the caster frame gently onto a level surface. Never drop or allow the frame to fall.
4. Block and brace the frame so that it will not move while the battery sections are installed on it.
5. Lift and gently place the range in position on the caster frame. Never drop or allow the range to fall.
6. Bolt the range to the caster frame.
7. Go to Installation Step 3.

## STEP 3: ATTACH RESTRAINT TO RANGE (OR BATTERY) MOUNTED ON CASTERS

### NOTICE

For an appliance equipped with casters, (1) the installation shall be made with a connector that complies with the *Standard for Connectors for Movable Gas Appliances, ANSI Z21.69* or *Connectors for Moveable Gas Appliances, CAN/CGA-6.16*, and a quick-disconnect device that complies with the *Standard for Quick-Disconnect Devices for Use With Gas Fuel, ANSI Z21.41*, or *Quick Disconnect Devices for Use with Gas Fuel, CAN1-6.9*, (2) adequate means must be provided to limit the movement of the appliance without depending on the connector and the quick-disconnect device or its associated piping to limit the appliance movement and (3) the restraining means should be attached to a frame member on the back of the unit.

Install the restraint cable to a range (or battery) mounted on casters using the following procedure:

1. Secure the restraining-device bracket (item "B" in Figure 15) to a wall stud located as close as possible to the appliance connector inlet and outlet connections. Use four #12 screws (items "C") and plastic anchors (items "A") if necessary.
2. Install eye-bolt (item "F") to a frame member on the rear of the equipment. After checking carefully behind the frame member for adequate clearance, drill a 1/4" hole through the frame member.
3. Thread hex nut (item "G") and slide the washer (item "H") onto the eye-bolt. Insert the eye-bolt through the 1/4" drilled hole and secure with a washer (item "H") and nylon lock nut (item "I").
4. Using the spring-loaded snap hooks, attach the restraining device to the bracket and the eye-bolt.
5. Using the cable clamp (item "D"), adjust the restraining device extended length to prevent over-bending or kinking of the appliance connector.

For units not equipped with flame safety devices, be sure all valves are turned off prior to disconnecting. After reconnecting, be sure all control knobs are turned off and all pilots are lit.

**NOTICE**

Adequate means must be provided to limit the movement of the appliance without depending on the connector and the quick-disconnect device or its associated piping to limit the appliance movement.

The restraining means should be attached to a frame member on the back of the unit.

Figure 15

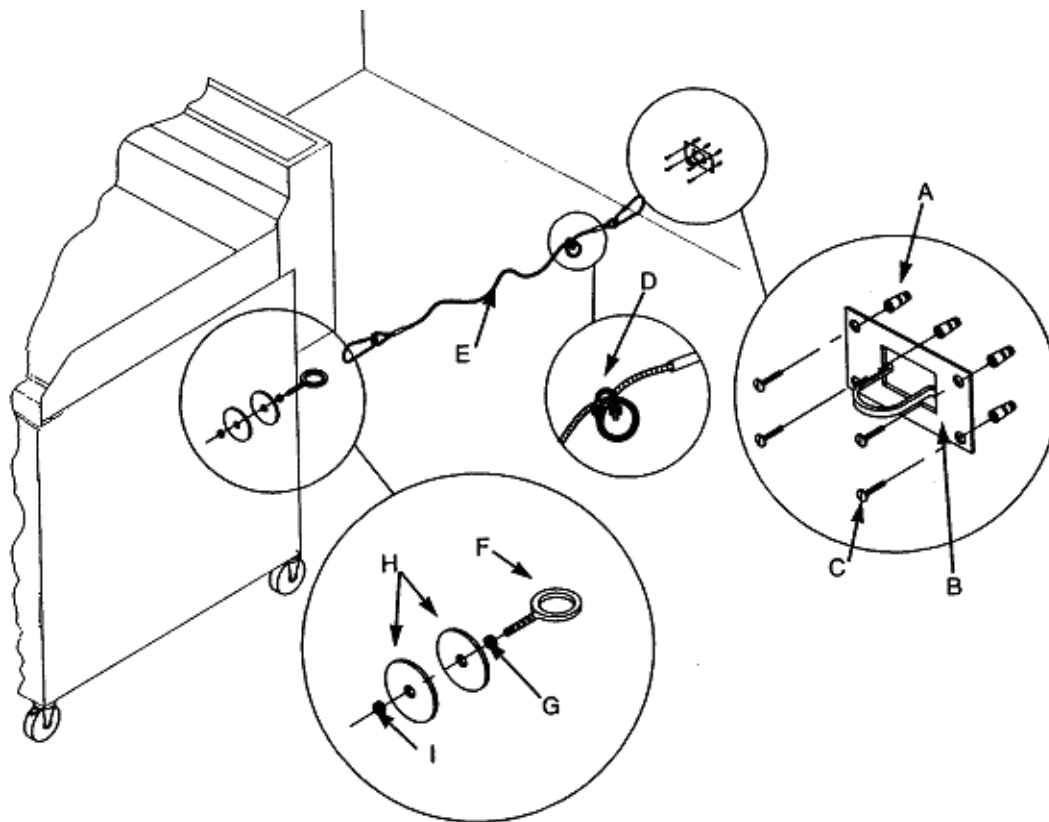
**Installation of Cable Restraint****STEP 4: CONNECT BATTERY SECTIONS**

If the range is part of a battery, and the battery was shipped partially disassembled, connect the battery sections using the following procedure.

1. Remove valve panels from all sections. Mark them so that they can be returned to their respective section.
2. Position the center section of the battery and carefully level that unit. Use a long spirit level four ways; across front top rail and the rear edge, and along each side edge.
3. If not already in place, attach pipe-union to front manifold of the battery. Screw it in far enough to be able to slide the adjacent section into position.
4. Bring up adjacent section and level it using the same method and by using the center unit as reference. Match front rails and rear edge. When a battery is set on a masonry base and legs are not used, shims may be used. Special attention should be given to griddle ranges to allow proper drainage.
5. Bolt the frames of the sections together.
6. Connect the front manifolds using the pipe-union.
7. Attach the trim-strip between the section tops.
8. Install the continuous front-rail, if ordered.
9. Slide control knobs onto their shafts (to operate the sections during the installation procedure), but do not yet reattach valve panels or front-panel trim pieces.

## STEP 5: ATTACH FLUE RISER AND SHELF ASSEMBLIES

Install the flue riser(s) using the following procedure (as shown in Figure 16).

1. Attach any salamander broilers and flue-riser-mounted cheese melters to appropriate sections following the installation procedure in the manuals for those options.
2. Slide each flue riser down onto the brackets projecting from the back of the corresponding section(s) of the sectional range. Secure the flue riser to the brackets with the four provided 1/4-20x3/4 hex-head bolts, flat washers, and lockwashers. Also, secure the bottom edge of the flue riser to the top rear edge of the sectional range using the provided #10 sheet metal screws.
3. If access to the interior of the flue riser is necessary to make gas connections, make those connections at this time.

Figure 16

### Installation of Flue Riser

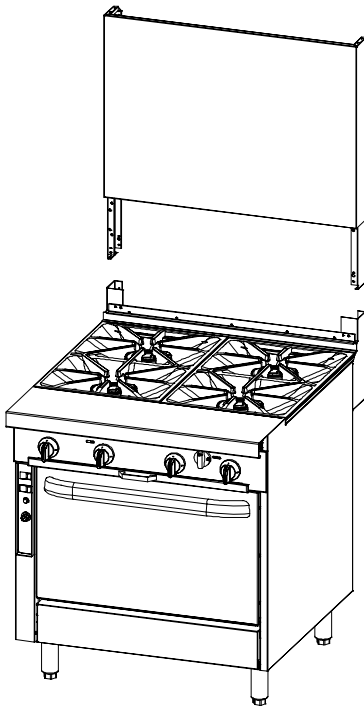

Slide the front of the flue riser down into the brackets on the sectional range.

Secure the flue riser to the brackets using the provided fasteners. Also secure the bottom edge of the flue riser to the top rear edge of the sectional range.

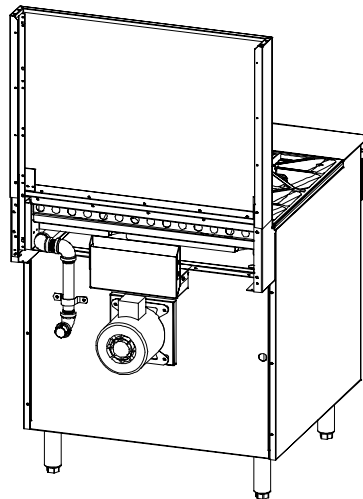

Attach the rear of the flue riser to the front of the flue riser using the provided fasteners.

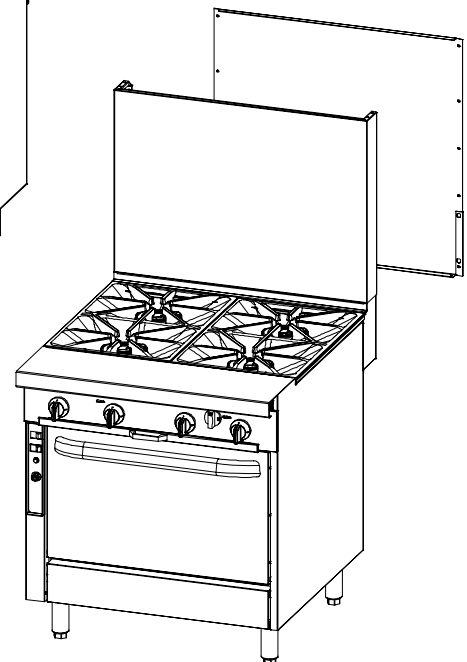

4. Attach each wall shield to the back of the corresponding flue riser using the provided #10 sheet metal screws.
5. Connect the top side edges of adjoining flue risers using the provided small plates and screws.
6. If tubed shelves were installed, place the tubes in place in the shelf brackets.
7. If sloped enclosures were ordered (for flue-mounted salamander broilers and/or cheese melters), install them at this time.

## STEP 6: CONNECT ELECTRICITY (FOR SECTIONS WITH OVEN-BASES)

A wiring diagram is located behind the kick panel of the oven-base ranges. Be sure that the input voltage and phase match the requirements shown on the serial plate.

Oven-base ranges ordered with a **115V, 60Hz, single-phase** electrical rating are factory-supplied with a three-wire cord with a three-prong plug that fits any standard three-prong grounded receptacle. Each standard oven requires a 15 ampere supply, while each convection oven requires a 20 ampere supply.

Oven-base ranges ordered with a **208/236V, 60Hz, single- or three-phase** electrical rating are factory-equipped with a two-pole terminal block located behind cover plate located on the rear of the unit. To connect the supply wires, remove the cover plate. Route the supply wires and the grounding wire through the strain relief fitting to the terminal block. Insert the supply wires, one each, into the two poles of the terminal block and tighten the screws. Insert the ground wire into the grounding lug and tighten the screw. Re-attach the cover plate.

Three phase units are wired as above, using only two supply wires. The third wire is not used and must be properly terminated.

All units are shipped wired as specified by factory order. Conversion between single-phase and three-phase can be accomplished by referring to phase loading and line amperes chart on the wiring diagram for wire size and ampere requirements.

## STEP 7: CONNECT GAS SUPPLY

If the sectional range is being installed at over 2,000 feet altitude and that information was not specified when ordered, contact the appropriate authorized Southbend Service Representative or the Southbend Service Department. Failure to install with proper orifice sizing will result in poor performance and may void the warranty.

The sectional range is design-certified for operation on natural or propane gases. The sectional range is shipped configured and adjusted for the type of gas specified by the purchaser, which is indicated on the serial plate (see Figure 1 on page 3). Connect the sectional range **ONLY** to the type of gas for which it is configured and adjusted.

Minimum supply pressure is 7" W.C. for natural gas, 11" W.C. for propane. An external pressure regulator and shut off valve are provided. If using a flexible-hose gas connection, the I.D. of the hose must not be smaller than the connector on the sectional range, and must comply with *ANSI Z21.69*. Provide an adequate means of restraint to prevent undue strain on the gas connection.

If applicable, the vent line from the gas pressure regulator shall be installed to the outdoors in accordance with local codes, or in the absence of local codes, with the *National Fuel Gas Code, ANSI Z223.1, Natural Gas Installation Code, CAN/CGA-B149.1*, or the *Propane Installation Code CAN/CGA-B149.2*, as applicable.

An adequate gas supply is imperative. Undersized or low pressure lines will restrict the volume of gas required for satisfactory performance. Fluctuations of more than 25% on natural gas or 10% on propane gas will create problems and affect burner operating characteristics. A 1/8" pressure tap is located on the manifold to measure the manifold pressure. The supply line to the sectional range should be no smaller than the inside diameter of the pipe on the sectional range to which it is connected.

### CAUTION

ALL PIPE JOINTS AND CONNECTIONS MUST BE TESTED THOROUGHLY FOR GAS LEAKS. USE ONLY SOAPY WATER FOR TESTING ON ALL GASES. NEVER USE AN OPEN FLAME TO CHECK FOR GAS LEAKS. ALL CONNECTIONS MUST BE CHECKED FOR LEAKS AFTER THE APPLIANCE HAS BEEN PUT INTO OPERATION. TEST PRESSURE SHOULD NOT EXCEED 14" W.C.

Do the following to connect the gas supply:

1. Check that all control knobs on the sectional range are in the OFF position.
2. Purge the gas supply line to clean out dust, dirt, or other foreign matter before connecting the line to the sectional range.

3. The gas connection piping may have been partially installed at the factory. If necessary, attach the gas connection of any appliances mounted on a flue riser.
4. Locate the pressure regulator(s) packed with the sectional range. Install the pressure regulator, taking care that the direction of gas flow corresponds to the arrow on the side of the pressure regulator.

 **CAUTION**

HOLD THE PRESSURE REGULATOR WITH A WRENCH WHEN TIGHTENING THE CONNECTION TO THE SUPPLY PIPE TO AVOID DAMAGE TO THE REGULATOR, VALVE, AND OTHER COMPONENTS.

5. Install a service shut-off valve to the pressure regulator, and connect the gas supply line to the shut-off valve.
6. If applicable, install the vent line of the pressure regulator to the outdoors.
7. Turn on the gas and immediately check for leaks using soapy water.
8. If the optional sloped enclosure for a flue-mounted model was ordered, install it at this time.

## STEP 8: CONNECT WATER SUPPLY

If a rail-mounted fill-hose was ordered (as a special option), there will be a corresponding water connection on the back of the section. Connect the water supply.

## STEP 9: CHECK THE INSTALLATION

Check the installation, as follows:

1. Check that all screws and bolts are tightened.
2. Check electrical connection(s).
3. Check that the gas connection has been made correctly.
4. Check water connection(s).
5. Move the battery into the final position at which it will be operated.
6. Check that the battery is level. If not, adjust the legs or casters.
7. Check that the appropriate minimum clearances are satisfied (see page 4).
8. Check that there is sufficient clearance to open all doors and pull-out all grease trays and crumb trays.
9. Check that adequate ventilation (fresh air supply and hood exhaust) is available to the room in which the appliance will operate.
10. Wipe clean all cooking surfaces (especially griddles).
11. Check that nothing is obstructing the air intake openings and/or the combustion-exhaust openings.

## STEP 10: CHECK OPERATION OF EACH SECTION

Check the operation of each section, as follows:

1. Turn electricity supply on.
2. Turn gas supply on. Immediately check all gas connections for leaks using soapy water.
3. Turn water supply on (if applicable). Check for water leaks.
4. Light all pilots (see the appropriate Operation section elsewhere in this manual). Start with the section(s) furthest from the gas supply connection(s) to purge air from the gas lines. Check all pilots for correct flame height.
5. Turn on the burners of each section using only the lowest temperature settings (for now). Check all burners for correct flame appearance and height.
6. Begin to break-in all griddle surfaces by turning on all griddle burners to LOW for at least one hour. (In case any problems occur, do not leave the battery unattended during this time!) This will temper the griddle surface and avoid possible damage.
7. Check operation of all sections (except griddles) for the full-range of operating settings, including checking all burners for correct flame appearance and height at the HIGH settings.
8. Complete the break-in of all griddle surfaces (after they have been operating at LOW for at least one hour) by gradually bringing each griddle up to frying temperature. Then spread over each griddle three or four ounces of

beef suet, or as a substitute, baking soda, to season it. Never allow water on a hot griddle and never wash it with soap and water.

9. Check that gas supply is adequate by simultaneously turning on all burners of all sections to their highest setting, then again checking that all burner flames have correct appearance and height.
10. Check that electricity supply is adequate by simultaneously turning on all electrical elements (if any) and turning the blower setting of all convection ovens (if any) to HIGH.
11. Check that water supply is adequate by simultaneously operating all fill hoses (if any). (Do not allow water to spill onto a hot griddle.)
12. Turn-off all burners and allow all battery sections to cool.

## STEP 11: ATTACH VALVE-PANEL(S) AND FRONT TRIM PANELS

Attach the valve panel(s) and front trim panels, as follows:

1. After the battery has cooled, again check all gas connections for gas leaks using soapy water.
2. Attach the front-trim panels for the adjoining sections.
3. Remove control knobs, grease drawers, and drippings-trays as necessary to enable installation of the valve panel(s).
4. Attach the valve panel(s).
5. Re-attach the control knobs. Insert all grease drawers and drippings trays.

## STEP 12: WIPE-CLEAN AND SHUT-DOWN RANGE

Complete the installation by leaving the sectional range ready for customer use:

1. Wipe clean all surfaces.
2. Unless the sectional range is to be placed in service immediately, shut off the gas, electricity, and water supplies.
3. Make sure that a copy of this manual will be available to the people who will operate and maintain the sectional range.



# SERVICE

## **WARNING**

ADJUSTMENTS AND SERVICE WORK MAY BE PERFORMED ONLY BY A QUALIFIED TECHNICIAN WHO IS EXPERIENCED IN, AND KNOWLEDGEABLE WITH, THE OPERATION OF COMMERCIAL COOKING EQUIPMENT. TO ASSURE YOUR CONFIDENCE, CONTACT YOUR AUTHORIZED SERVICE AGENCY FOR RELIABLE SERVICE, DEPENDABLE ADVICE OR OTHER ASSISTANCE, AND FOR GENUINE FACTORY PARTS.

## **NOTICE**

INSTALLATION OF OTHER THAN GENUINE SOUTHBEND PARTS WILL VOID THE WARRANTY ON THIS EQUIPMENT.

The location of the serial plate depends on the type of base (see Figure 1 on page 3). On models with oven bases, the serial plate is located on the backside of the kick-plate below the oven door (lift the kick-plate straight up and tilt the top edge out and down.) On models with a cabinet base, the serial plate is located inside the left cabinet door. On modular (countertop) models, the serial plate is located inside the front valve panel.

Replacement parts (including parts not listed in this manual) may be ordered either through a Southbend Authorized Parts Distributor or a Southbend Authorized Service Agency.

When ordering parts, please supply the Model Number, Serial Number, Part Number, and Part Description.

## ACCESS TO SERVICEABLE COMPONENTS

To open the kick panel below the oven door, lift the kick panel straight up and pull the top edge away from the oven. The kick panel is hinged at the bottom corners.

To remove the valve panel, first remove the knobs. Then remove the two screws on the bottom of the valve panel (except on modular-countertop base models). Pull the bottom of the valve panel away from the range. The top edge of the valve panel has two small slots that hook over tabs on the frame.

To access the rear of the oven control panel, first remove the valve panel. Then remove the screw that holds the top of the oven control panel in place. Tilt the top of the oven control panel outward, being careful not to damage the wires or the thermostat sensor.

To service the blower motor from the front of the oven, first remove the blower baffle from the rear of the oven cavity (lift it up and out). Then disconnect the motor-mount plate by removing the eight hex nuts that secure it to the oven interior back. Pull the mount-plate, with motor attached, into the oven cavity.

## TROUBLESHOOTING BURNERS AND PILOTS

The following table lists the possible causes of burner and pilot related problems that may occur.

Problem	Look for -
None of the burners and pilots will turn on	– Main gas supply to unit is OFF.
All burners produce excessive carbon deposits	– Incorrect gas type is being supplied to the range. – Incorrect gas supply pressure.
Only some burners produce excessive carbon deposits	– Incorrect orifices. – Primary air not adjusted properly.
Only some pilots produce excessive carbon deposits	– Pilot not adjusted properly. – Incorrect pilot orifice.
Top burner (not oven) will not come on	– Pilot out. – For thermostatic griddles, gas shut off valve is in OFF position. – For thermostatic griddles, button on safety switch is not being held in long enough after lighting pilot.
Top section pilot will not remain lit	– Pilot flame not adjusted properly. – Clogged orifice. – Draft condition. – Improper ventilation system. – Air in gas line.

## SERVICING BURNERS AND PILOTS

All orifice sizes and burner rates are properly set at the factory and should not be altered.

Each burner should have a steady blue flame on each port of the burner. When using propane, the burners may have a small amount of yellow tipping.

If the flame is rising up off of the ports adjust the burner shutter to be further closed. If the flame is long and yellow adjust the burner shutter to be further open.

Over-gassed burners DO NOT heat as efficiently as those that are properly adjusted. Such conditions also create “hot spots” on griddles and hot tops. Floating and unstable burner and pilot flames will result when solid tops are lowered into position because the rear openings of the burner compartment are not adequate to vent the enormous flue products generated by over-gassed burners. The “unburned” gas will ignite at the rear and burn in this section and even up inside the flue riser, causing structural members in this area to deteriorate. Also, some of these hot flue products will vent forward into the manifold compartment resulting in problems with valves and thermostats due to overheating. AGAIN, over-gassed burners waste energy and cause service problems.

Note that the burners of griddle, charbroiler, and uniform hot-top models are long, and so the burner flame may float when cold. Allow the burner to heat before making burner adjustments.

Propane burners may have a slight popping noise when turned off. This is normal.

Check that the burner is level and in its support brackets.

Check that the burner is clean and all of its ports are clear.

Check that each burner valve and orifice is in alignment with the burner.

Remove the burner and check that its venturi is clean and free of buildup and debris.

With each burner removed check that the orifice size is correct and clean and free of buildup and debris.

If it is necessary to remove a griddle top to service the burners, use extreme care since the griddle plate is very heavy. When raising a thermostatic griddle top, remove the thermostat bulbs from the tubes on the bottom of the griddle plate. When re-installing, re-insert the thermostat bulbs and be sure the capillary tubes are away from burners, flames and excessive heat.

Pilot-flame outage is often due to an unstable flame caused by over-adjustment to the point where the pilot flame is leaving its port, or "blowing off." Sometimes the pilots are increased too much in an effort to improve ignition, resulting in this unstable condition.

Figure 17

### Adjustment of Charbroiler, Standard-Griddle, and Uniform Hot-Top Burners and Pilots

The burner valves are not adjustable. The burner orifice is of the fixed type, sized for the type of gas and the operating altitude. To adjust the burner air-gas mixture, loosen the screw that secures the air shutter on the mixer face and rotate the mixer cap to obtain a clear, stable blue flame with a distinct inner cone at each port. Excessive primary air causes "blowing" (the flames leaving the ports), while insufficient primary air causes a soft or yellow tipped flame.

The pilots are near the front of the burners, and are held in position by brackets. To adjust a pilot flame, insert a screwdriver through the opening in the valve panel between the control knobs and turn the appropriate pilot adjustment screw counterclockwise to increase the size of the pilot flame, or clockwise to decrease the size of the pilot flame. The maximum flame size is approximately 3/4" with a slight yellow tip. The first indication of over-adjustment is when the flame tip becomes more yellow and begins to generate carbon, which appears as rising black streaks. Continued over-adjustment leads to unstable lifting and a blowing condition.

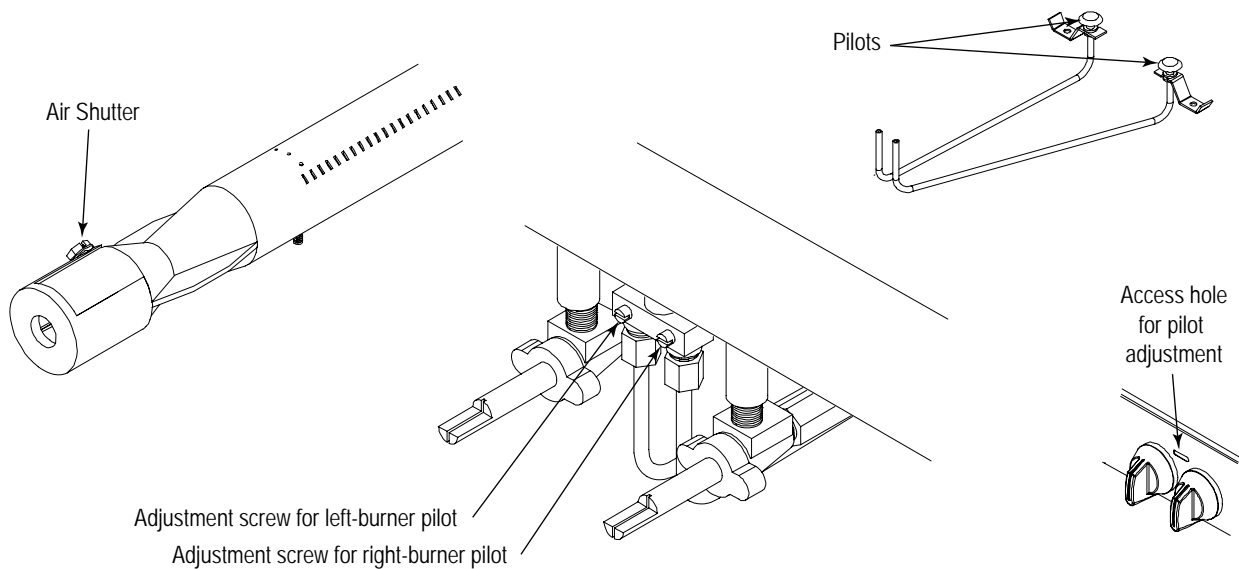

Figure 18

## Adjustment of Graduated Hot-Top Pilot and Burner

The burner valves are not adjustable. The burner orifice is of the fixed type, sized for the type of gas and the operating altitude. To adjust the burner air-gas mixture, loosen the screw that secures the air shutter on the mixer face and rotate the mixer cap to obtain a clear, stable blue flame with a distinct inner cone at each port. Excessive primary air causes "blowing" (the flames leaving the ports), while insufficient primary air causes a soft or yellow tipped flame.

The pilot is beside the burner, and is held in position by a bracket. To adjust the pilot flame, insert a screwdriver through the opening in the valve panel beside the control knob and turn the pilot adjustment screw counterclockwise to increase the size of the pilot flame, or clockwise to decrease the size of the pilot flame. The maximum flame size is approximately 3/4" with a slight yellow tip. The first indication of over-adjustment is when the flame tip becomes more yellow and begins to generate carbon, which appears as rising black streaks. Continued over-adjustment leads to unstable lifting and a blowing condition.

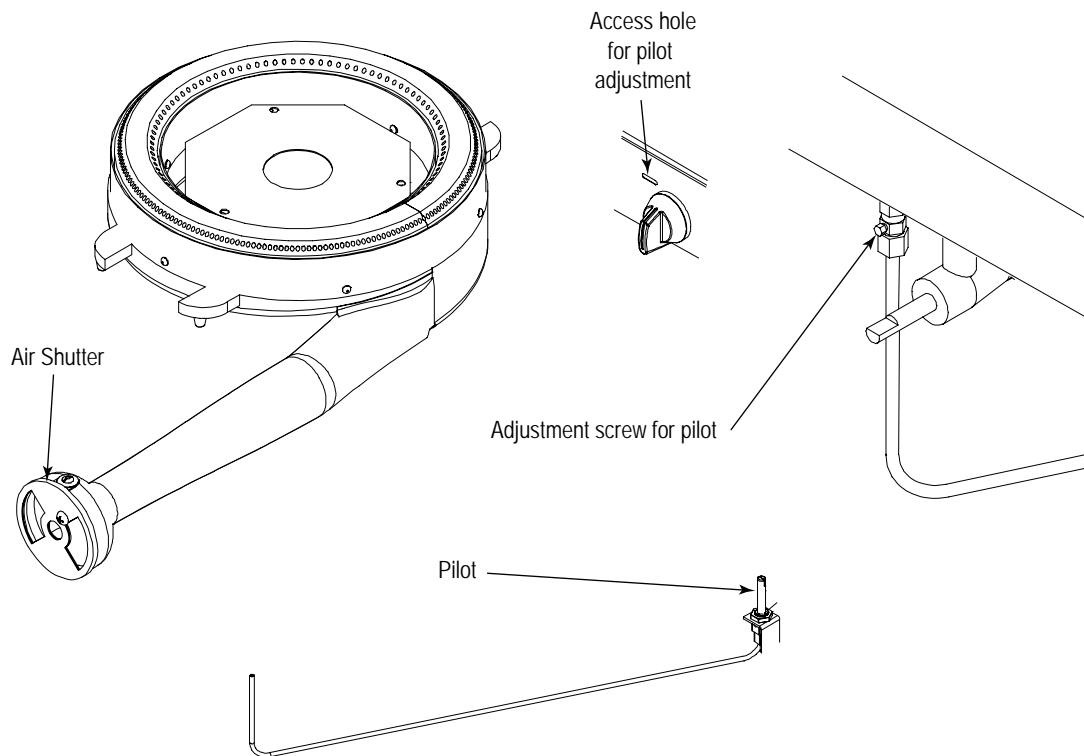

Figure 19

### Adjustment of 33K and 45K Open-Top Burners and Pilots

The burner valves are not adjustable. The burner orifice is of the fixed type, sized for the type of gas and the operating altitude. To adjust the burner air-gas mixture, loosen the screw that secures the air shutter on the mixer face and rotate the mixer cap to obtain a clear, stable blue flame with a distinct inner cone at each port. Excessive primary air causes "blowing" (the flames leaving the ports), while insufficient primary air causes a soft or yellow tipped flame.

The pilots are beside the burners, and are held in position by brackets. To adjust a pilot flame, insert a screwdriver through the opening in the valve panel between the control knobs and turn the appropriate pilot adjustment screw counterclockwise to increase the size of the pilot flame, or clockwise to decrease the size of the pilot flame. The maximum flame size is approximately 3/4" with a slight yellow tip. The first indication of over-adjustment is when the flame tip becomes more yellow and begins to generate carbon, which appears as rising black streaks. Continued over-adjustment leads to unstable lifting and a blowing condition.

33K-Open-Burner Models

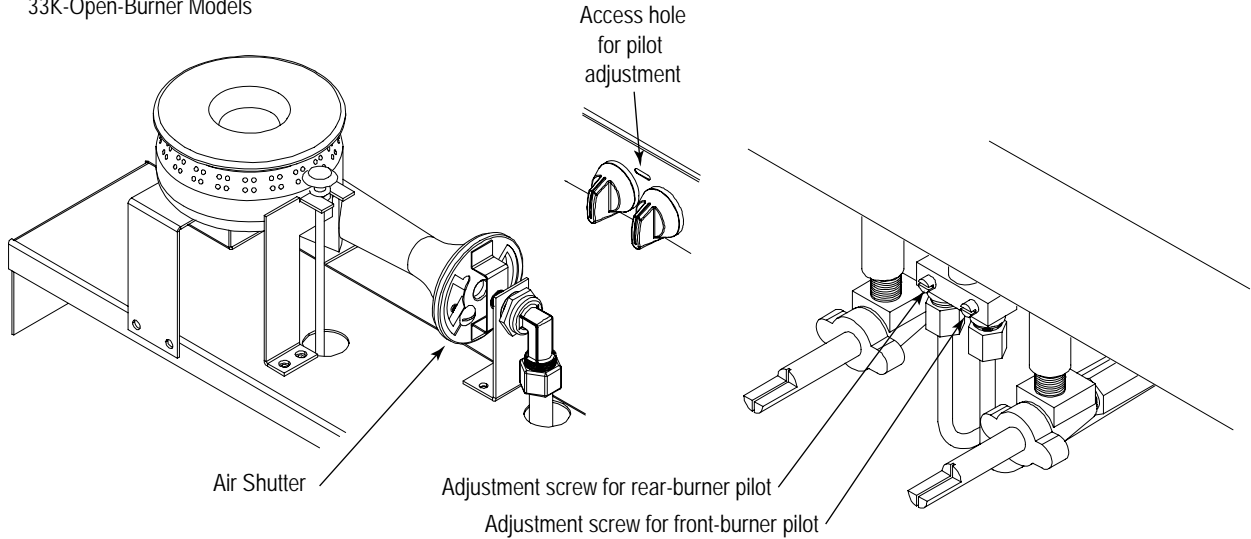

45K-Open-Burner Model

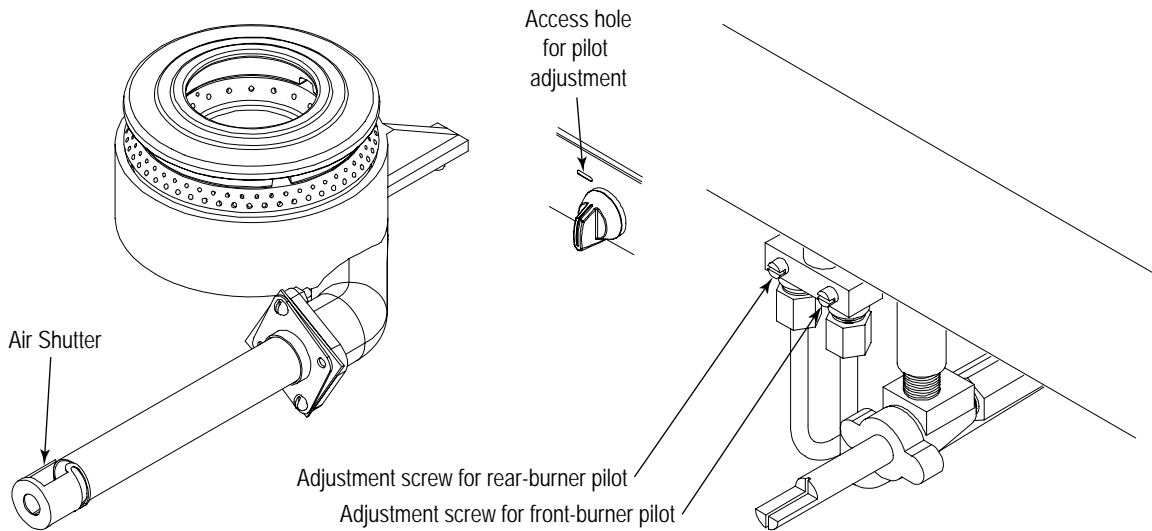

Figure 20

## Adjustment of Thermostatic-Griddle Thermostat

Each 16"-wide section of a thermostatic griddle has a control knob that operates a snap-action thermostatic valve. Each valve is adjusted at the factory. If the griddle surface temperature is different from the thermostat dial setting, adjust the thermostatic valve using the following procedure:

1. Turn all the control knobs to the 300°F.
2. Wait 30 minutes for the griddle temperature to stabilize (or 1 hour if the griddle was cold).
3. Place a reliable thermometer or test-instrument thermocouple (able to register 300°F) halfway back from the front to the back of the griddle and directly in line with the 16"-wide section's control knob (see drawing below). Check the temperature of each section every five minutes until the temperature does not change by more than 30°F between two consecutive measurements.
4. If the average temperature of any section is not within 30°F of the knob setting (300°F), adjust the corresponding thermostatic valve. To do so, remove the control knob (being careful to not turn the stem, which would change the temperature setting). While holding the stem in place, turn the calibration screw (see drawing below). If the actual measured temperature is lower than the dial setting, turn the screw counterclockwise. If the measured temperature is higher than the dial setting, turn the screw clockwise. Replace the control knob.
5. Wait for the griddle temperature to stabilize, then again check the temperature (as described above).

Measure temperature of each 16"-wide section half-way back and in line with control knob.

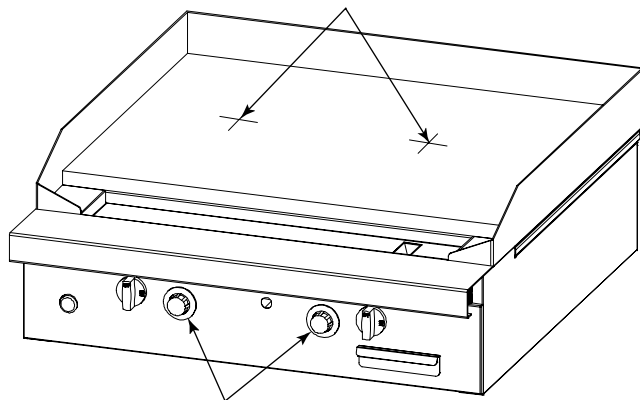

Each knob is attached to a thermostatic valve located behind the valve panel.

With a control knob removed, its valve shaft will extend out of the valve panel.

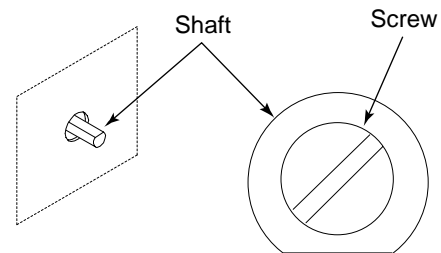

Calibrate the thermostat by holding the shaft in place while turning the screw counterclockwise to increase the temperature, or clockwise to decrease the temperature.

Figure 21

## Adjustment of Thermostatic-Griddle Burners and Pilot

The thermostatic burner valve is adjustable (see page 38). The burner orifice is of the fixed type, sized for the type of gas and the operating altitude. To adjust the burner air-gas mixture, loosen the screw that secures the air shutter on the mixer face and rotate the mixer cap to obtain a clear, stable blue flame with a distinct inner cone at each port. Excessive primary air causes "blowing" (the flames leaving the ports), while insufficient primary air causes a soft or yellow tipped flame.

The pilot(s) and pilot-runner(s) are located near the front of the burners, but the pilot adjustment valve is located in the gas line between the safety switch and the pilot. If the pilot needs adjustment, do the following:

1. Remove the control knobs, and remove the valve panel (see page 33).
2. If necessary, light the pilot.
3. Locate the pilot adjustment valve (see drawing below). Turn the pilot adjustment screw counterclockwise to increase the size of the pilot flame, or clockwise to decrease the size of the pilot flame. The pilot flame should be about 1/2" high with a slight yellow tip, and cover the thermocouple tip. The first indication of over-adjustment is when the flame tip becomes more yellow and begins to generate carbon, which appears as rising black streaks. Continued over-adjustment leads to unstable lifting and a blowing condition.
4. Replace the valve panel and control knobs.

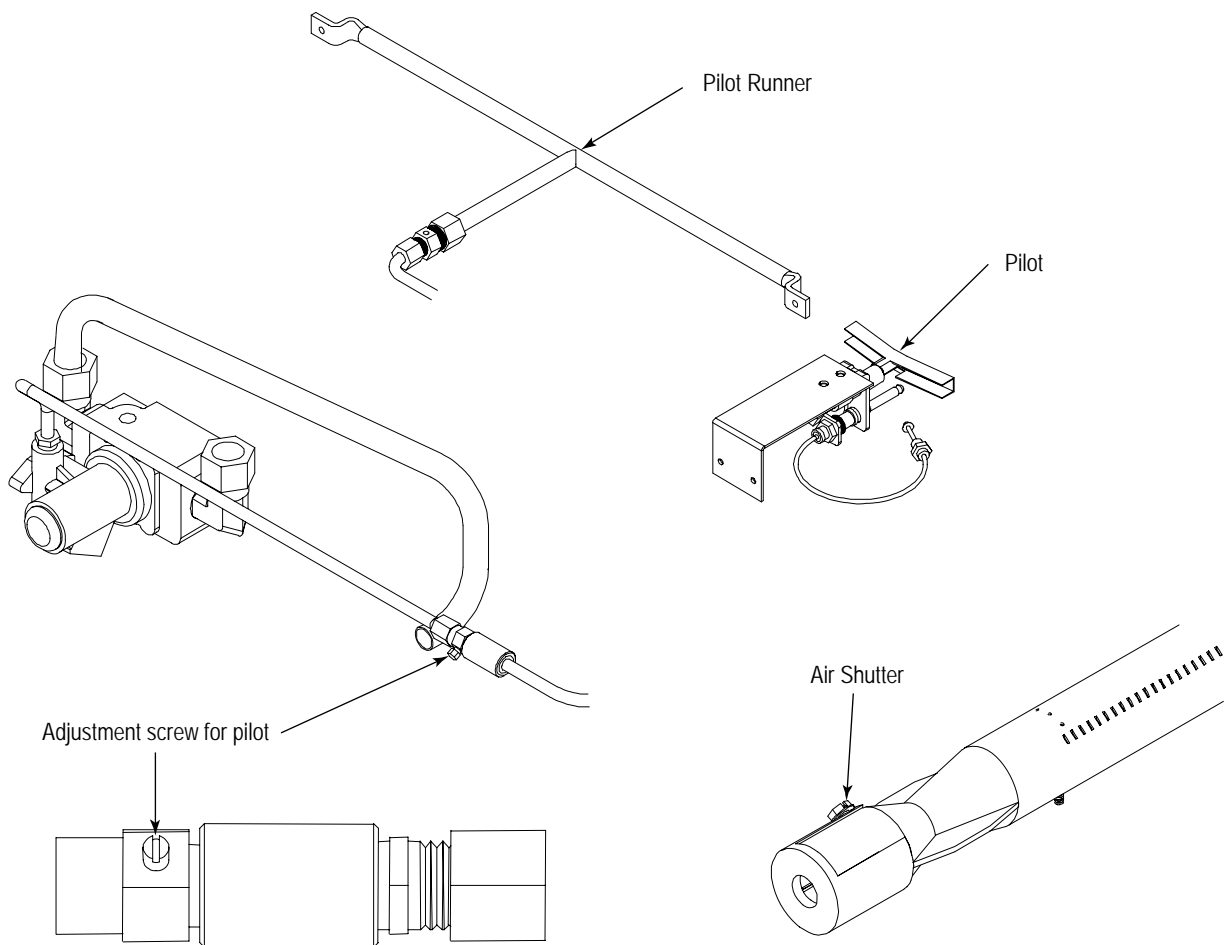

## TROUBLESHOOTING OVEN

 **CAUTION**

Proper and efficient operation of oven is dependent on correct installation and function of components. Always verify that components are in place and functioning as intended.

The following table lists the possible causes of oven-related problems that may occur.

Problem	Look for -1
Oven will not come on.	<ul style="list-style-type: none"> <li>- Oven gas shut-off valve is OFF</li> <li>- Power switch is OFF</li> <li>- Problem with power switch</li> <li>- Problem with pilot solenoid</li> <li>- Problem with main gas solenoid</li> <li>- Problem with wiring</li> <li>- Problem with spark ignition module</li> <li>- Problem with flame sensor switch</li> </ul>
Oven pilot will not light	<ul style="list-style-type: none"> <li>- Oven gas shut-off valve is OFF</li> <li>- Problem with power switch</li> <li>- Problem with pilot solenoid</li> <li>- Problem with wiring</li> <li>- Problem with spark ignition module</li> </ul>
Convection blower motor will not run	<ul style="list-style-type: none"> <li>- Problem with fan speed switch</li> <li>- Problem with door switch</li> <li>- Problem with blower motor</li> <li>- Problem with wiring</li> </ul>
Oven will not maintain set temperature	<ul style="list-style-type: none"> <li>- Problem with oven thermostat</li> <li>- Problem with door switch</li> </ul>
Oven door too difficult to lift	<ul style="list-style-type: none"> <li>- Problem with door spring</li> <li>- Problem with door roller assembly</li> </ul>

## SERVICING CONVECTION OVEN BLOWER MOTOR

 **WARNING**

Before attempting to service or replace any electrical component, make sure that the power source has been disconnected.

 **CAUTION**

When changing motor or servicing unit, always verify that blower wheel rotation is clockwise when looking into the oven cavity.

The motor is serviceable from the front of the unit through the oven cavity (see page 33).

Motor lubrication information can be found on the permanent label located on the motor.

If the blower does not run at all, consult the wiring diagrams in this manual (see page 45), or behind the oven kick plate.

If the blower runs intermittently, consult the following flowchart.



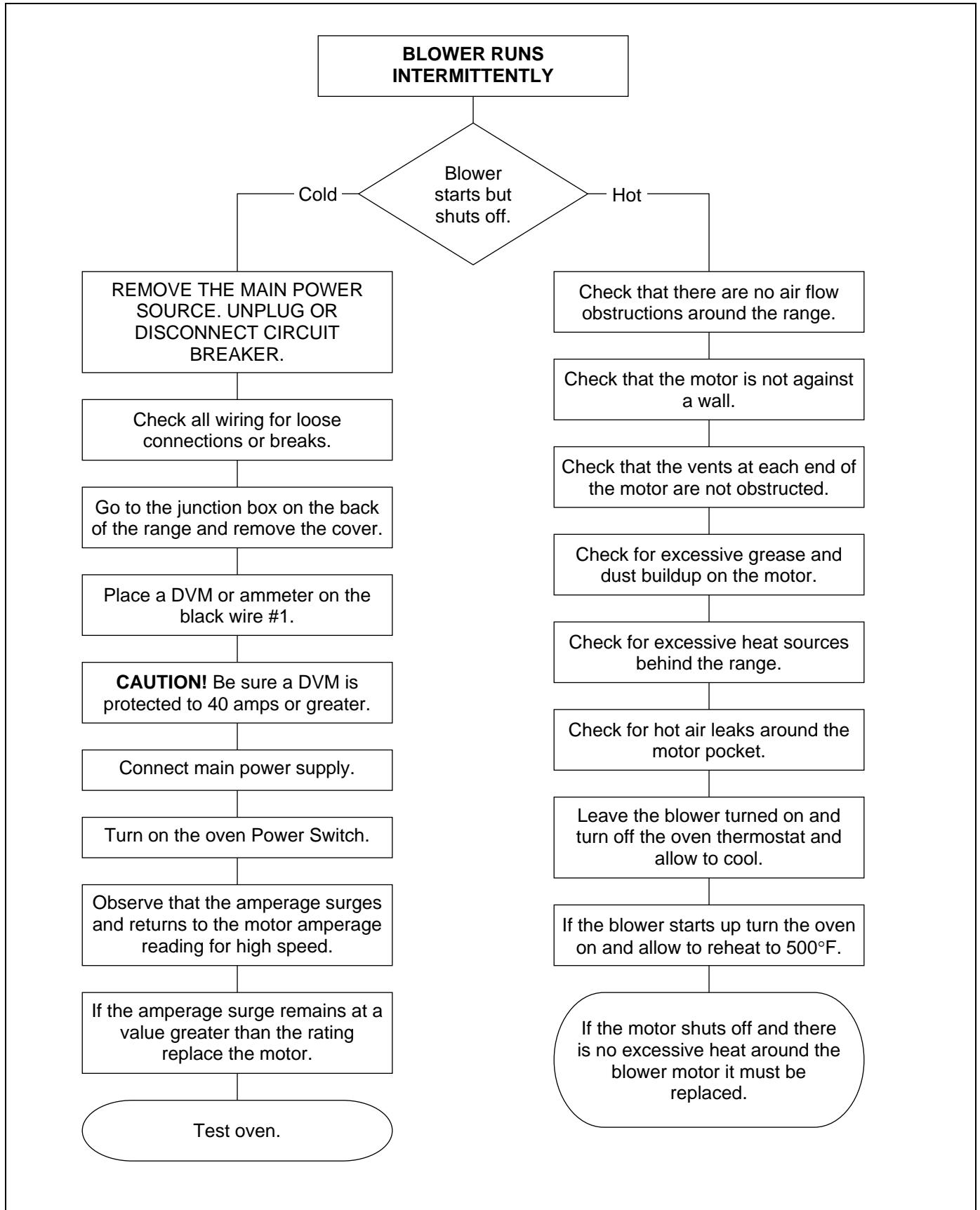

Figure 22

## Adjustment of Oven Thermostat

The oven thermostat is carefully calibrated at the factory so that the dial setting matches the actual oven temperature. Field recalibration is seldom necessary, and should not be resorted to unless considerable cooking experience definitely proves that the control is not maintaining the temperatures to which the dial is set.

Obtain a test instrument or a reliable mercury thermometer, then do the following:

1. Place the thermocouple of test instrument or the thermometer in the middle of the oven.
2. Turn on the oven and set the thermostat to 400°F.
3. After the oven has been on about 20 minutes check oven temperature. The oven door should be open for as short a time as possible. Use a flashlight, if necessary, to see the thermometer clearly.
4. Continue to check the temperature at 5-minute intervals until two successive readings are within 5 degrees of each other.

The thermostat should be recalibrated if the reading is not within 20 degrees of the dial setting (400°F). If calibration is required, adjust the thermostat, as follows:

5. Remove the oven temperature control knob. Be careful to not turn the stem (which would change the temperature setting).
6. While holding the stem in place, turn the calibration screw (see drawing below). If the actual measured temperature is lower than the dial setting, turn the screw counterclockwise. If the measured temperature is higher than the dial setting, turn the screw clockwise. Replace the control knob.
7. Set the oven temperature to 450°F. After about 20 minutes, check the oven temperature. Continue to check the temperature at 5-minute intervals until two successive readings are within 5 degrees of each other. If the actual oven temperature is not within 20 degrees of the dial setting (450°F), replace the thermostat.

Remove oven thermostat control knob.

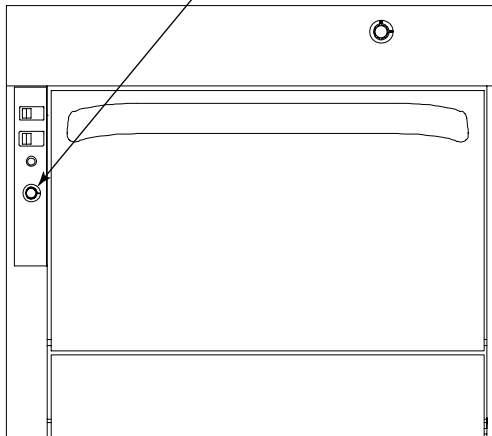

With the control knob removed, the control shaft will extend out of the control panel.

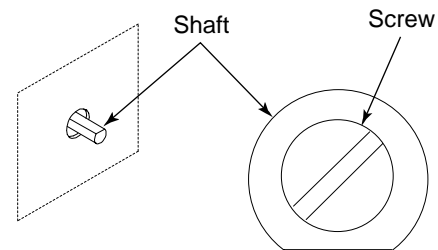

Calibrate the thermostat by holding the shaft in place while turning the screw counterclockwise to increase the temperature, or clockwise to decrease the temperature.

Figure 23

### Adjustment of Oven Pilot and Burner

The burner orifice is of the fixed type, sized for the type of gas and the operating altitude. To adjust the burner air-gas mixture, loosen the screw that secures the air shutter on the mixer face and rotate the mixer cap to obtain a clear, stable blue flame with a distinct inner cone at each port. Excessive primary air causes "blowing" (the flames leaving the ports), while insufficient primary air causes a soft or yellow tipped flame.

The oven pilot flame is adjusted by using a screwdriver to turn the adjusting screw on the pilot line valve (see drawing below). The pilot line valve is located behind the kick panel below the oven door. To gain access, lift the kick panel straight up and pull the top edge out. The pilot flame is properly adjusted when it is just large enough to maintain a glowing red color of the flame switch capillary bulb. The first indication of over-adjustment is when the flame tip becomes yellow and begins to generate carbon, which appears as rising black streaks. Continued over-adjustment leads to unstable lifting and a blowing condition.

#### UNITS WITH ELECTRONIC IGNITION

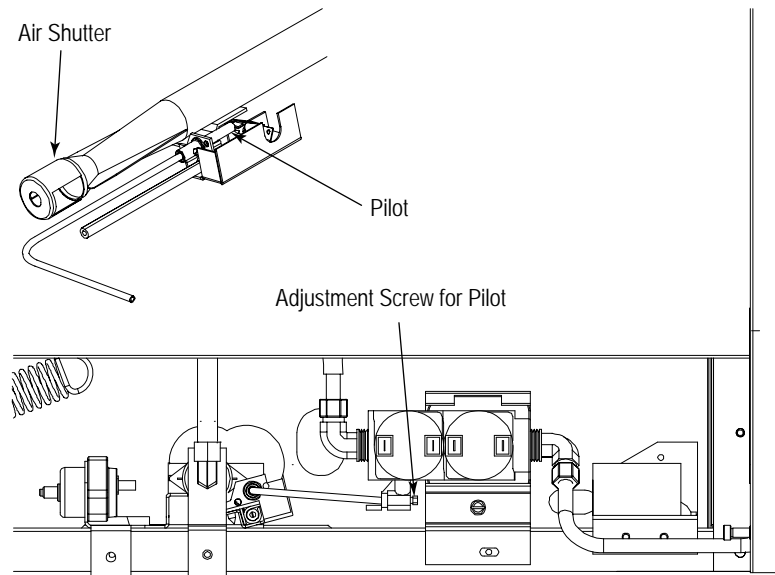

#### UNITS WITH STANDING PILOT

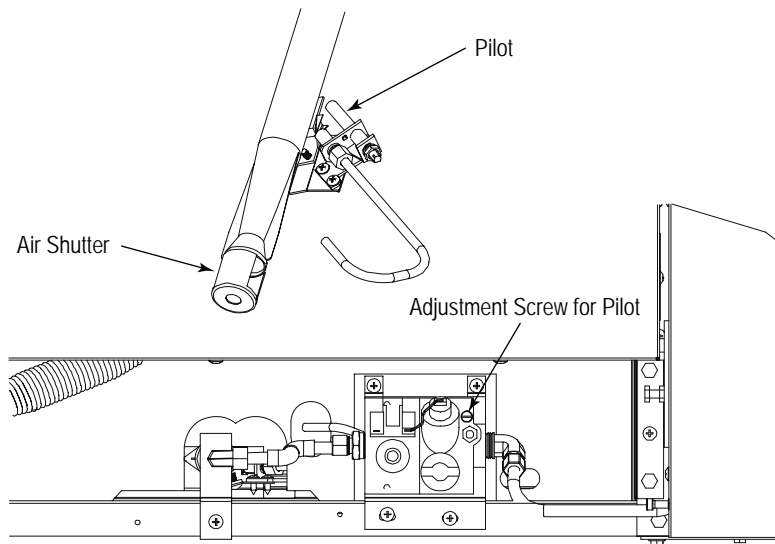

## ADJUSTMENT OF MANIFOLD GAS PRESSURE

There is not an internal pressure regulator. The external pressure regulators supplied by Southbend are factory set at 6" W.C. for natural gas and 10" W.C. for propane gas. To check the manifold pressure, do the following:

1. Turn OFF all thermostats, burner controls, gas shut-off valves, and the external gas supply connection(s).
2. Remove the valve panel and locate the 1/8" plug in the front manifold furthest from the gas connection location. Remove the plug and install a fitting appropriate to connect a manometer.
3. Turn ON all gas supply valves and light all pilots.
4. Turn all burners and ovens to full ON position and read manometer.
5. If manometer does not read 6" W.C. for natural gas (or 10" W.C. for propane gas) adjust regulator by removing the cap from the top of regulator. Use a screwdriver to rotate the regulator adjustment screw clockwise to increase pressure, or counterclockwise to decrease pressure, until manometer shows correct reading.
6. Turn OFF all thermostats, burner controls, gas shut-off valves, and the external gas supply connection(s).
7. Remove manometer fitting and replace plug in manifold.
8. Turn ON all gas valves and light all pilots.
9. Replace valve panel.

Figure 24

Wiring Diagram for 120 Volt Oven Bases with Electronic Ignition

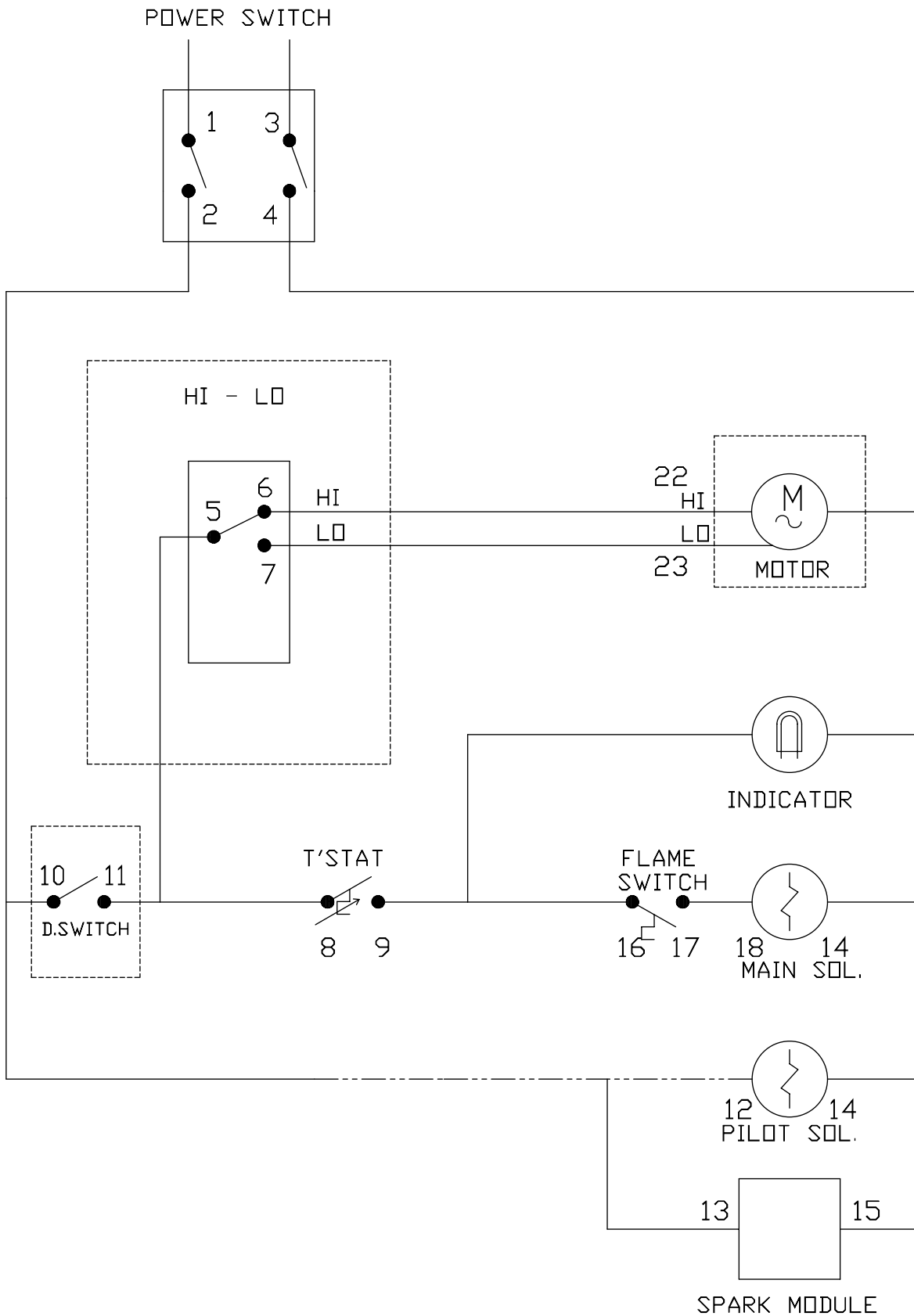
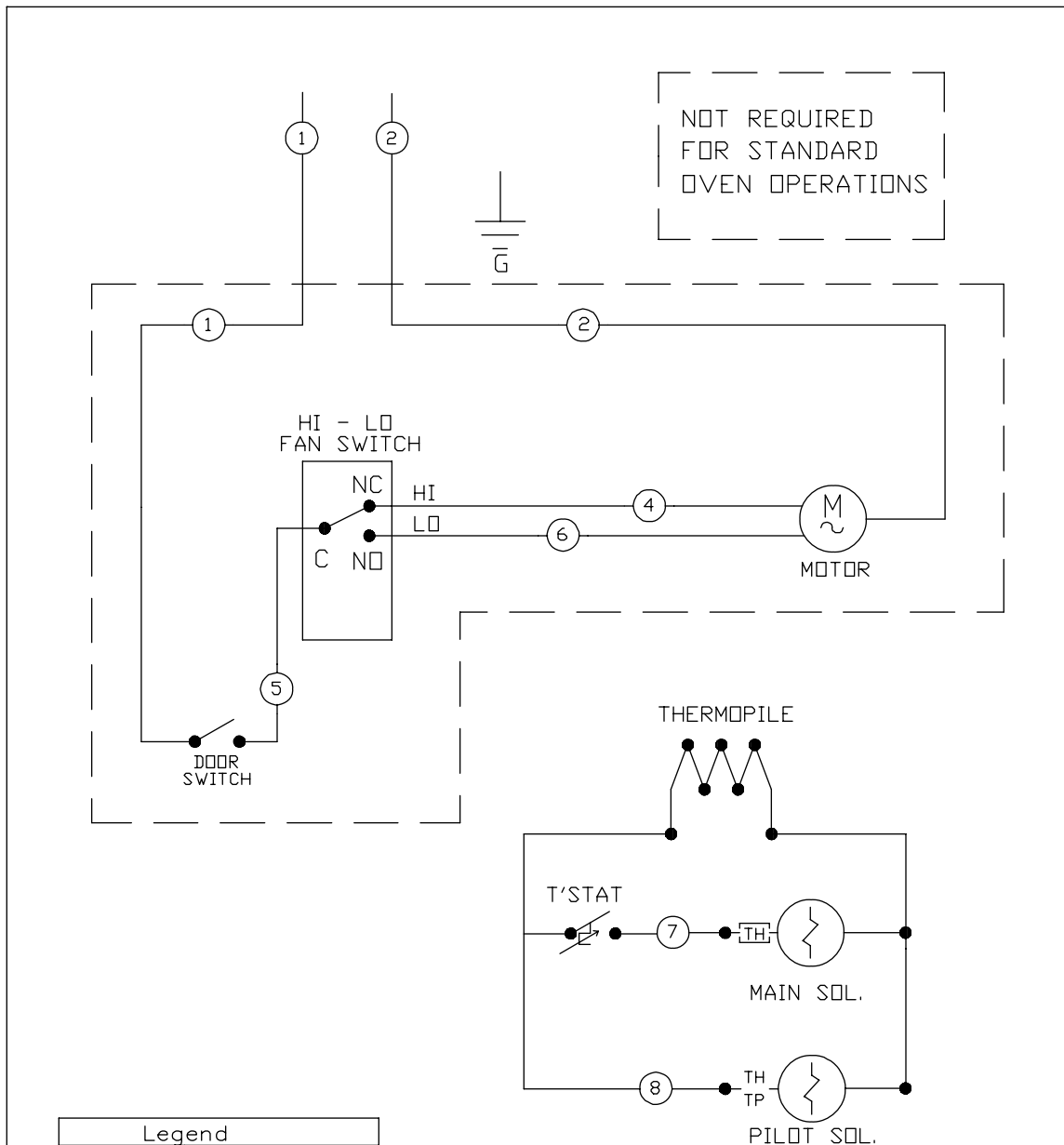

Figure 25

Wiring Diagram for Oven Bases with Standing Pilot



Legend	
○	WIRE NO'S
●	CONNECTIONS

VOLTAGE	110	120	220	240
PHASE	SINGLE	SINGLE	SINGLE	SINGLE
AMPERAGE	15	15	20	20

NOTICE: THIS WIRING DIAGRAM WAS CURRENT AS BUILT

WIRING DIAGRAM	P/N
110/120 V & 220/240 V	1189815
SECTIONAL RANGE	

## PARTS

The following tables and figures list serviceable parts. For parts not listed, contact a Southbend Authorized Parts Distributor or a Southbend Authorized Service Agency.

<b>Index of Parts Diagrams</b>	
<b>Page Number</b>	<b>Description</b>
48	33K-Open-Burner External and Structural Parts
50	33K-Open-Burner Gas Train Parts
52	45K-Open-Burner Parts
54	Charbroiler External and Structural Parts for 16" and 32" Models
56	Charbroiler External and Structural Parts for 24", 36", and 48" Models
58	Wood Smoker External and Structural Parts for 36", 48", 60" and 72" Models
60	Charbroiler and Standard-Griddle Gas Train Parts
61	Gas Connection Parts
62	Griddle External and Structural Parts
64	Thermostatic Griddle Gas Train Parts
66	Uniform Hot-Top Parts
68	Graduated-Hot-Top Parts
70	Oven Base Parts
72	Convection Oven Blower Parts
73	Modular-Countertop Base Parts
74	Cabinet-Base Parts
76	Flue Riser Parts
78	Front-Rail Parts
79	Shelf Parts
80	Side Panel and Battery-Assembly Parts
81	Leg and Caster Parts

### 33K-Open-Burner External and Structural Parts

See drawing on following page.

Key	Part Number	Quantity*				Description
		12"	32"	36"	48"	
1	1183978	1	-	-	-	TRAY ASSEMBLY, 12" CRUMB
	1183970	-	1	-	-	TRAY ASSEMBLY, 32" CRUMB
	1187061	-	-	1	-	TRAY ASSEMBLY, 36", SS
	1185401	-	-	-	1	TRAY W/A, 48 CHARBROILER CRUMB LT
	1185486	-	-	-	1	TRAY W/A, 48 CHARBROILER CRUMB RT
2	1189600	2	6	6	8	KNOB
3	1184729	1	-	-	-	VALVE PANEL, 12C-B (cabinet base)
	1184730	1	-	-	-	VALVE PANEL, 12N-B (modular-countertop base)
	1185830	-	1	-	-	VALVE PANEL, 32A/D-BBB (oven base)
	1185916	-	1	-	-	VALVE PANEL, 32C-BBB (cabinet base)
	1185915	-	1	-	-	VALVE PANEL, 32N-BBB (modular-countertop base)
	1184550	-	-	1	-	VALVE PANEL, 36A/D-BBB (oven base)
4	1184760	2	-	-	-	BURNER REST, 12
	1184759	-	-	-	4	BURNER REST, 24
	1185562	-	**	-	-	BURNER REST, 32
	1184578	-	-	2	-	BURNER REST, 36
5	1183883	1	-	-	-	SUPPORT, 12 PILOT (for flush-top models)
	1185847	-	1	-	-	SUPPORT, 32 PILOT (for flush-top models)
	1183601	-	-	1	-	SUPPORT, 36 PILOT (for flush-top models)
6	1180872	1	3	3	4	BRACKET, PILOT SUPPORT (for flush-top models)
7	1183888	1	-	-	-	TRIM, 12 FLUE RISER
	1183560	-	1	-	-	TRIM, 32 FLUE RISER
	1183531	-	-	1	-	TRIM, 36 FLUE RISER
8	1183900	1	-	-	-	TRIM, 42 DEEP 12 FLUE RISER
	1183588	-	1	-	-	TRIM, 42 DEEP 32 FLUE RISER
	1183529	-	-	1	-	TRIM, 42 DEEP 36 FLUE RISER
9	1183500	1	-	3	4	CAST IRON GRATE, SECTIONAL 12"
10	1173385	-	2	-	-	CAST IRON GRATE, BBB 32"
11	1185833	-	1	-	-	SUPPORT W/A, STEP-UP 32" GRATE
	1184671	-	-	1	-	SUPPORT W/A, STEP-UP 36" GRATE
12	1185849	-	1	-	-	BURNER REST, 32" STEP-UP
	1184648	-	-	1	-	BURNER REST, 36" STEP-UP
13	1177109	-	3	3	-	BRACKET, REAR BURNER REST (for step-up models)
14	1177107	-	3	3	-	BRACKET, ORIFICE (for rear burners of step-up models)
15	1177108	-	3	3	-	BRACKET, REAR PILOT (for rear pilots of step-up models)
16	1184790	-	3	3	-	BRACKET, STEP-UP PILOT (for front pilots of step-up models)
***	1185377	-	-	2	-	DRIP SHIELD
***	1190520	-	-	1	-	PLUG, DOME PLATED

\* Quantity of part used may depend on width of section (12", 32", 36", or 48").

\*\* Two for flush-top models, one for step-up models.

\*\*\* Not shown on drawing.

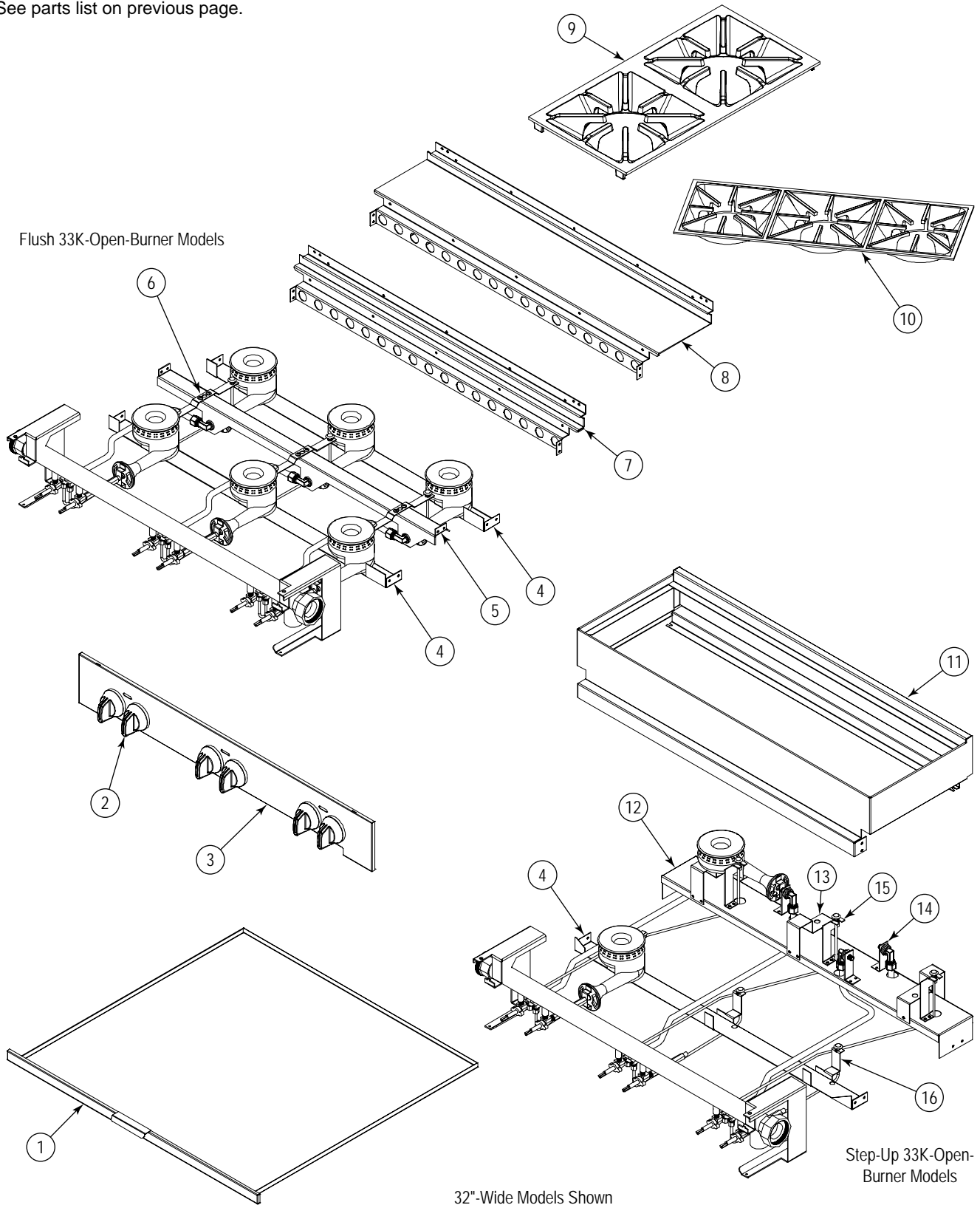

Figure 26

### 33K-Open-Burner External and Structural Parts

See parts list on previous page.

Flush 33K-Open-Burner Models



Step-Up 33K-Open-Burner Models

32"-Wide Models Shown

### 33K-Open-Burner Gas Train Parts

See drawing on following page.

Key	Part Number	Quantity*				Description
		12"	32"	36"	48"	
1	1183923	1	-	-	-	MANIFOLD W/A, 2 BURNER OPEN TOP
	1185667	-	1	-	-	MANIFOLD W/A
	1183596	-	-	1	-	MANIFOLD W/A
2	1179222	2	6	6	8	NIPPLE, EXTENSION
3	1178202	2	6	6	8	VALVE, HI-OFF, NAT/LP
4	1179188	1	3	3	4	EXTENSION, ORIFICE
**	1008741	2	6	6	8	ORIFICE, NAT GAS (if appliance will operate above 2000 ft, contact Southbend for appropriate orifice size)
	1008751	2	6	6	8	ORIFICE, PROPANE (if appliance will operate above 2000 ft, contact Southbend for appropriate orifice size)
5	1182193	2	6	6	8	BURNER ASSEMBLY, OPEN TOP
**	1182195	1	3	3	4	FITTING, 1/2" COMP 1/4" NPT (connects rear-burner gas tube to valve)
6	1182192	1	3	3	4	TUBE, REAR BURNER
7	1182191	1	3	3	4	ORIFICE FITTING
8	1166004	1	3	3	4	FITTING, DOUBLE PILOT, 3/16" TUBE
9	1183605	1	3	3	4	PILOT TUBE W/A REAR
10	1183603	1	3	3	4	PILOT TUBE W/A FRONT
11	1177106	-	3	3	-	TUBE ASM, REAR BURNER PILOT (for rear pilots of step-up models)
12	1184646	-	2	2	-	TUBE, REAR BURNER STEP-UP (for left rear and center rear burner of step-up models)
13	1184647	-	1	1	-	TUBE, REAR BURNER STEP-UP (for right rear burner of step-up models)

\* Quantity of part used may depend on width of section (12", 32", or 48").  
 \*\* Not shown on drawing.

Figure 27

### 33K-Open-Burner Gas Train Parts

See parts list on previous page.

Flush 33K-Open-Burner Models

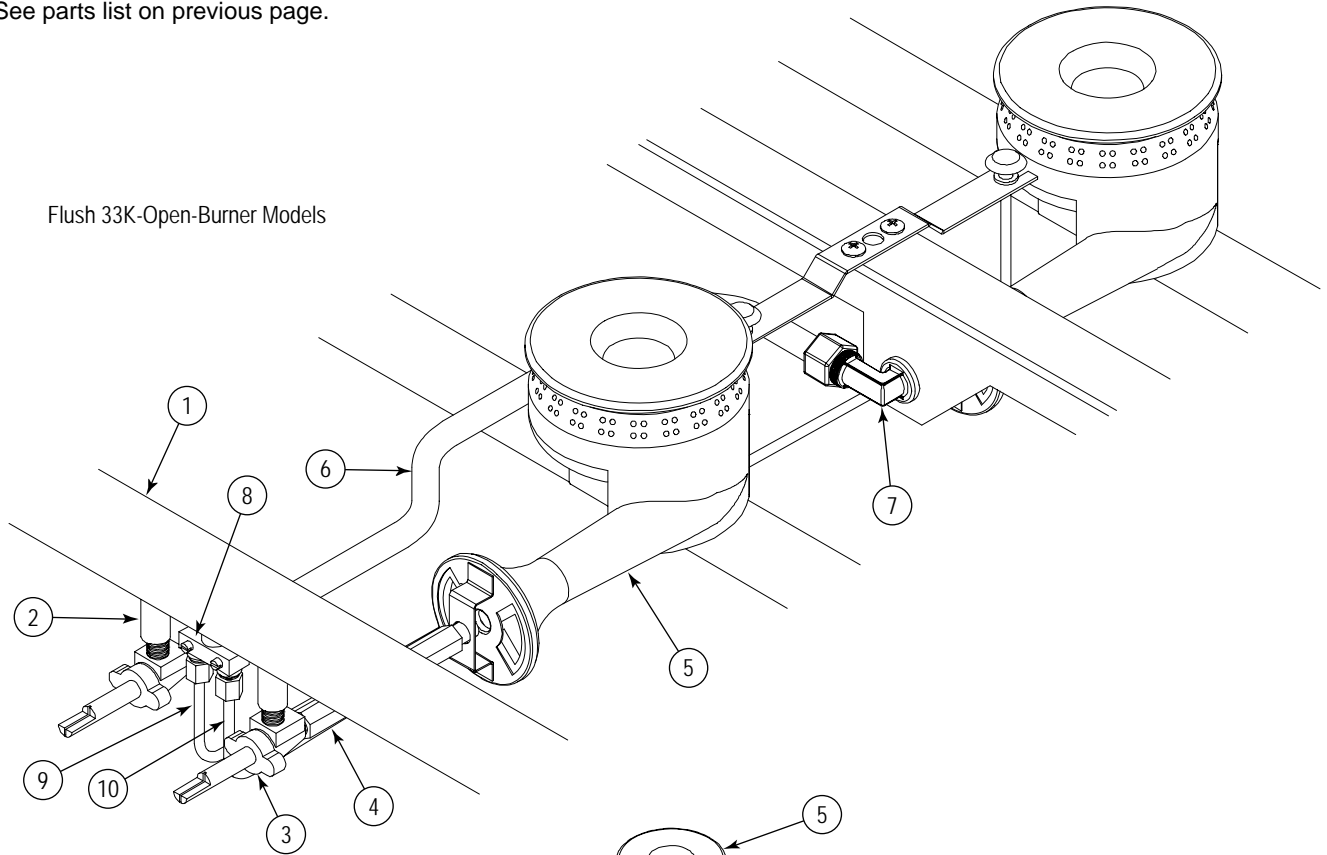

Step-Up 33K-Open-Burner Models

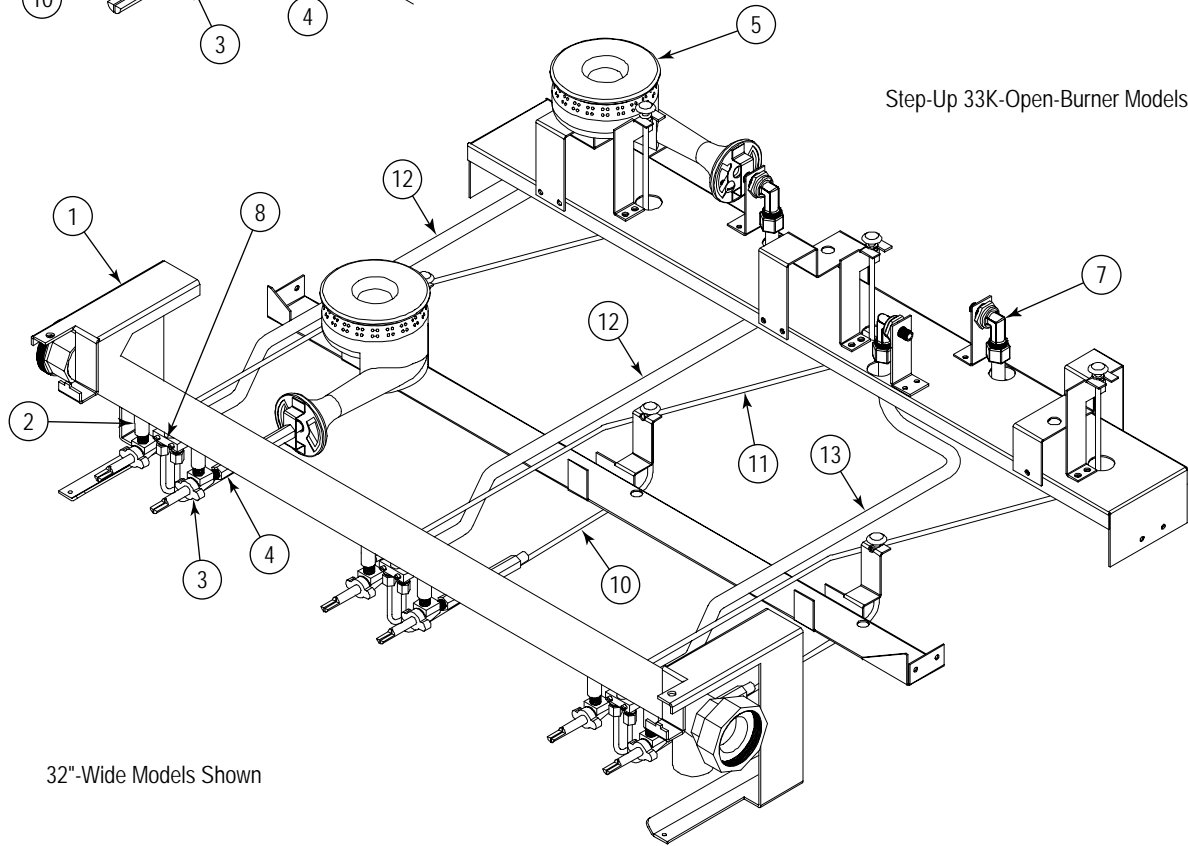

32"-Wide Models Shown

## 45K-Open-Burner Parts

See drawing on following page.

Key	Part Number	Quantity*		Description
		16"	32"	
1	1189600	2	4	KNOB
2	1184762	1	-	VALVE PANEL, 16C-X (cabinet base)
	1184731	1	-	VALVE PANEL, 16N-X (modular-countertop base)
	1183562	-	1	VALVE PANEL, 32A/D-XX (oven base)
	1183644	-	1	VALVE PANEL, 32C-XX (cabinet base)
	1183577	-	1	VALVE PANEL, 32N-XX (modular-countertop base)
3	1183976	1	-	TRAY ASSEMBLY, 16" CRUMB
	1183970	-	1	TRAY ASSEMBLY, 32" CRUMB
4	1184599	2	-	BURNER SUPPORT [16"]
	1185562	-	2	BURNER SUPPORT [32"]
5	1179229	1	2	SUPPORT, PILOT
6	1183887	1	-	TRIM 36 DEEP 16 FLUE RISER
	1183560	-	1	TRIM 36 DEEP 32 FLUE RISER
7	1183899	1	-	TRIM 42 DEEP 16 FLUE RISER
	1183588	-	1	TRIM 42 DEEP 32 FLUE RISER
8	1179247	1	2	CAST IRON GRATE
9	1185853	1	-	MANIFOLD W/A [16"]
	1183558	-	1	MANIFOLD W/A [32"]
10	1179222	2	4	NIPPLE, EXTENSION
11	1178202	2	4	VALVE, HI-OFF, NAT/LP
**	1008735	2	4	ORIFICE, NAT GAS (if appliance will operate above 2000 ft, contact Southbend for appropriate orifice size)
	1008750	2	4	ORIFICE, PROPANE (if appliance will operate above 2000 ft, contact Southbend for appropriate orifice size)
12	1165742	1	2	VENTURI (for front burners)
13	1165741	1	2	VENTURI (for rear burners)
14	1179230	2	4	BURNER HEAD, 40
15	1177043	2	4	COVER, BURNER DRIP
16	1166004	1	2	FITTING, DOUBLE PILOT, 3/16" TUBE
17	1179246	1	2	PILOT W/A, REAR
18	1179244	1	2	PILOT W/A, FRONT
19	1179240	1	2	BURNER (for front)
	1179241	1	2	BURNER (for rear)
* Quantity of part used may depend on width of section (16" or 32").				
** Not shown on drawing.				

Figure 28

### 45K-Open-Burner Parts

See parts list on previous page.

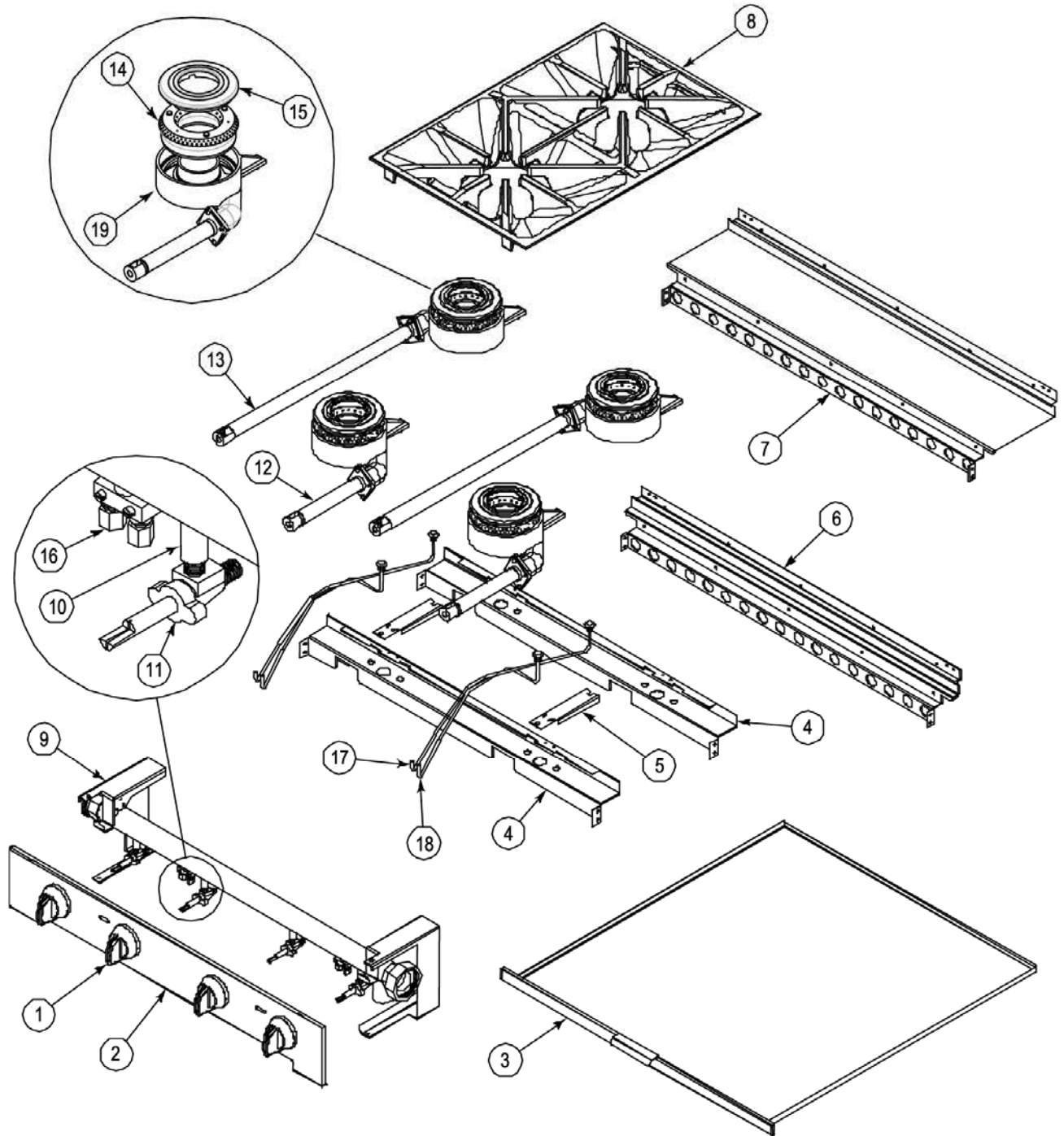

## Charbroiler External and Structural Parts for 16" and 32" Models

See drawing on following page.

Key	Part Number	Quantity*		Description
		16"	32"	
1	1189600	1	2	KNOB
2	1185945	1	-	VALVE PANEL, 16C-C, SS
	1185767	1	-	VALVE PANEL, 16N-C, SS
	1185691	-	1	VALVE PANEL, 32A/D-CC, SS
	1185692	-	1	VALVE PANEL, 32C-CC, SS
	1185693	-	1	VALVE PANEL, 32N-CC, SS
3	1184773	1	2	COVER, VALVE SHIELD
4	1185564	1	-	BRACKET, ORIFICE 16"
	1185563	-	1	BRACKET, ORIFICE 32"
5	1185944	1	-	SHIELD, 16" VALVE HEAT
	1185694	-	1	SHIELD, 32" VALVE HEAT
6	1185646	1	-	SHIELD, 16" CHARBROILER HEAT
	1185645	-	1	SHIELD, 32" CHARBROILER HEAT
7	1183976	1	-	TRAY W/A, 16 CHARBROILER CRUMB
	1183970	-	-	TRAY W/A, 32 CHARBROILER CRUMB
8	1185654	1	2	SHIELD, CHAR HEAT DEFLECTOR
9	1185642	1	-	SUPPORT, 16" CHAR REAR GRATE
	1185648	-	1	SUPPORT, 32 CHAR REAR GRATE
10	1185632	1	-	TRIM, CHAR/GRI 16 FLUE RISER
	1185631	-	1	TRIM, CHAR/GRI 32 FLUE RISER
**	1185946	1	-	TRIM, 42 DEEP CHAR/GRI 16 FLUE RISER
	1185671	-	1	TRIM, 42 DEEP CHAR/GRI 32 FLUE RISER
11	1185661	1	-	CHARBROILER W/A, 16
	1185660	-	1	CHARBROILER W/A, 32
12	1183541	1	1	SHIELD, LEFT DRIP
13	1183542	1	1	SHIELD, RIGHT DRIP
14	1185642	1	-	SUPPORT, 16" CHRBRRLR GRATE
	1185641	-	1	SUPPORT, 32" CHRBRRLR GRATE
15	1185640	1	-	SHIELD, 16" REAR DRIP
	1185639	-	1	SHIELD, 32" REAR DRIP
16	1185647	1	2	RADIANT W/A 32
17	1182657	2	5	GRATE, LAVA ROCK
**	1173193	2	5	LAVA ROCK BRIQUETTES, BAG
18	1178976	2	5	CHARBROILER GRID
**	1182838	2	5	PLATED FISH GRID

\* Quantity of part used may depend on width of section (16" or 32")  
 \*\* Not shown on drawing.

Figure 29

### Charbroiler External and Structural Parts for 16" and 32" Models

See parts list on previous page.

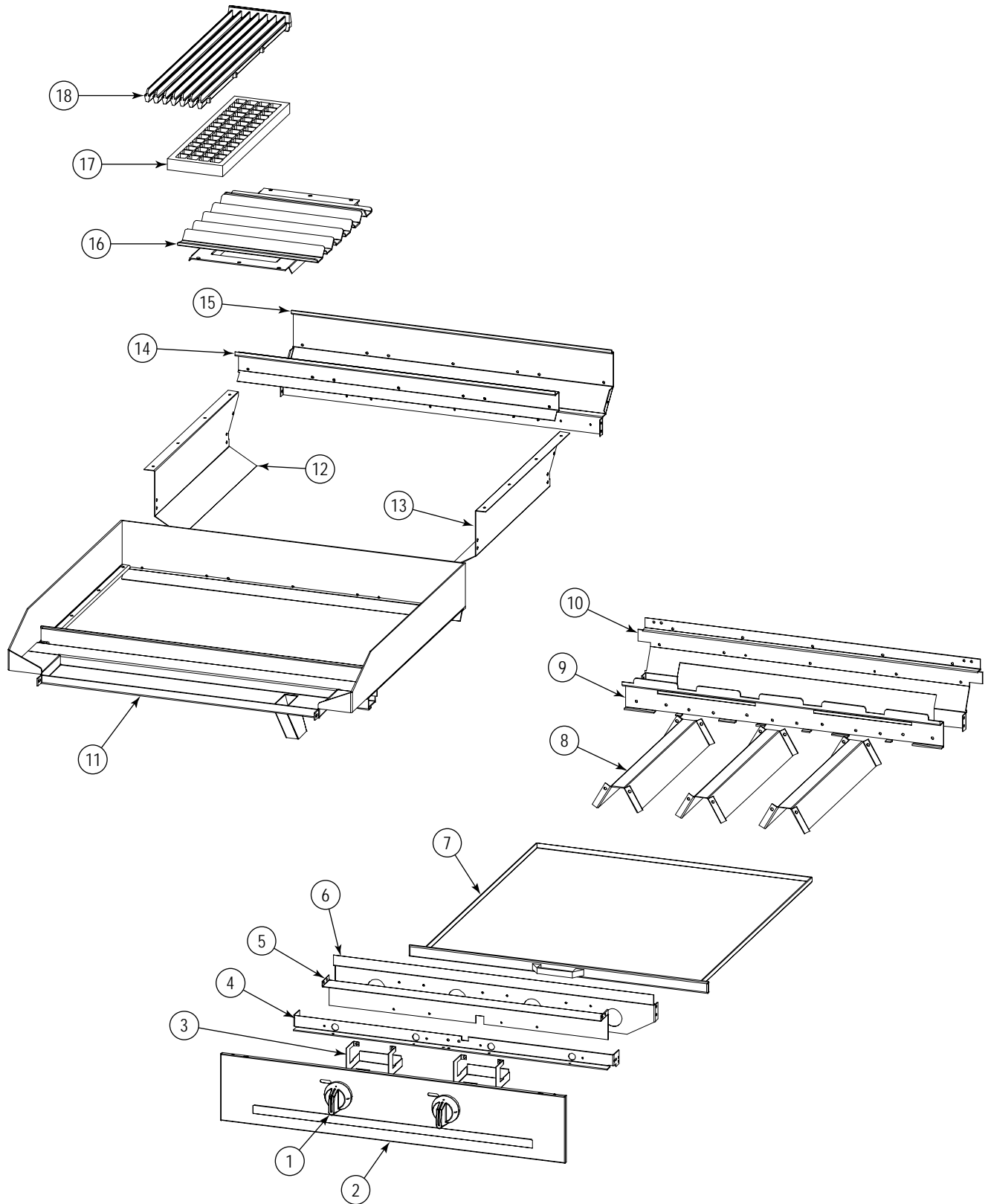

## Charbroiler External and Structural Parts for 24", 36", and 48" Models

See drawing on following page.

Key	Part Number	Quantity*			Description
		24"	36"	48"	
1	1189600	2	3	4	KNOB
2	1184519	1	-	-	VALVE PANEL, 24C-CC, SS
	1184521	1	-	-	VALVE PANEL, 24N-CC, SS
	1183641	-	1	-	VALVE PANEL, 36A/D-CCC, SS
	1183643	-	1	-	VALVE PANEL, 36C-CCC, SS
	1183642	-	1	-	VALVE PANEL, 36N-CCC, SS
	1185396	-	-	1	VALVE PANEL, 48A/D-CCCC, SS
	1185397	-	-	1	VALVE PANEL, 48C-CCCC, SS
	1185398	-	-	1	VALVE PANEL, 48N-CCCC, SS
3	1184773	2	3	4	COVER, VALVE SHIELD
4	1184523	1	-	-	SHIELD, 24" VALVE HEAT
	1184522	-	1	-	SHIELD, 36" VALVE HEAT
	1185379	-	-	1	SHIELD, 48" VALVE HEAT
5	1183896	1	-	-	BURNER REST, 24 CHAR/GRI
	1183524	-	1	-	BURNER REST, 36 CHAR/GRI
	1183895	-	-	1	BURNER REST, 48 CHAR/GRI
6	1183901	1	-	-	SHIELD, 24" CHARBROILER HEAT
	1184543	-	1	-	SHIELD, 36" CHARBROILER HEAT
	1185388	-	-	1	SHIELD, 48" CHARBROILER HEAT
7	1183974	2	-	-	TRAY W/A, 24 CHARBROILER CRUMB
	1184772	-	2	-	TRAY W/A, 36 CHARBROILER CRUMB
	1185401	-	-	1	TRAY W/A, 48 CHARBROILER CRUMB LT
	1185486	-	-	1	TRAY W/A, 48 CHARBROILER CRUMB RT
8	1184994	2	3	4	BRACKET, RADIANT STOP
9	1183890	1	-	-	TRIM, CHAR/GRI 24 FLUE RISER
	1183635	-	1	-	TRIM, CHAR/GRI 36 FLUE RISER
	1183889	-	-	1	TRIM, CHAR/GRI 48 FLUE RISER
10	1183893	1	-	-	TRIM, 42 DEEP CHAR/GRI 24 FLUE RISER
	1183590	-	1	-	TRIM, 42 DEEP CHAR/GRI 36 FLUE RISER
	1183892	-	-	1	TRIM, 42 DEEP CHAR/GRI 48 FLUE RISER
11	1183541	1	1	1	SHIELD, LEFT DRIP
12	1183542	1	1	1	SHIELD, RIGHT DRIP
13	1183610	1	-	-	SUPPORT, 24" CHRBRRLR GRATE
	1183609	-	1	-	SUPPORT, 36" CHRBRRLR GRATE
	1183649	-	-	1	SUPPORT, 48" CHRBRRLR GRATE
14	1183926	1	-	-	SHIELD, 24" REAR DRIP
	1183525	-	1	-	SHIELD, 36" REAR DRIP
	1183928	-	-	1	SHIELD, 48" REAR DRIP
15	1183786	1	-	-	CHARBROILER W/A, 24
	1183646	-	1	-	CHARBROILER W/A, 36
	1183789	-	-	1	CHARBROILER W/A, 48
16	1183676	2	3	4	RADIANT W/A
17	1182657	4	6	8	GRATE, LAVA ROCK
**	1173193	4	6	8	LAVA ROCK BRIQUETTES, BAG
18	1178976	4	6	8	CHARBROILER GRID
**	1182838	4	6	8	PLATED FISH GRID

\* Quantity of part used may depend on width of section (24", 36" or 48")

\*\* Not shown on drawing.



Figure 30

### Charbroiler External and Structural Parts for 24", 36", and 48" Models

See parts list on previous page.

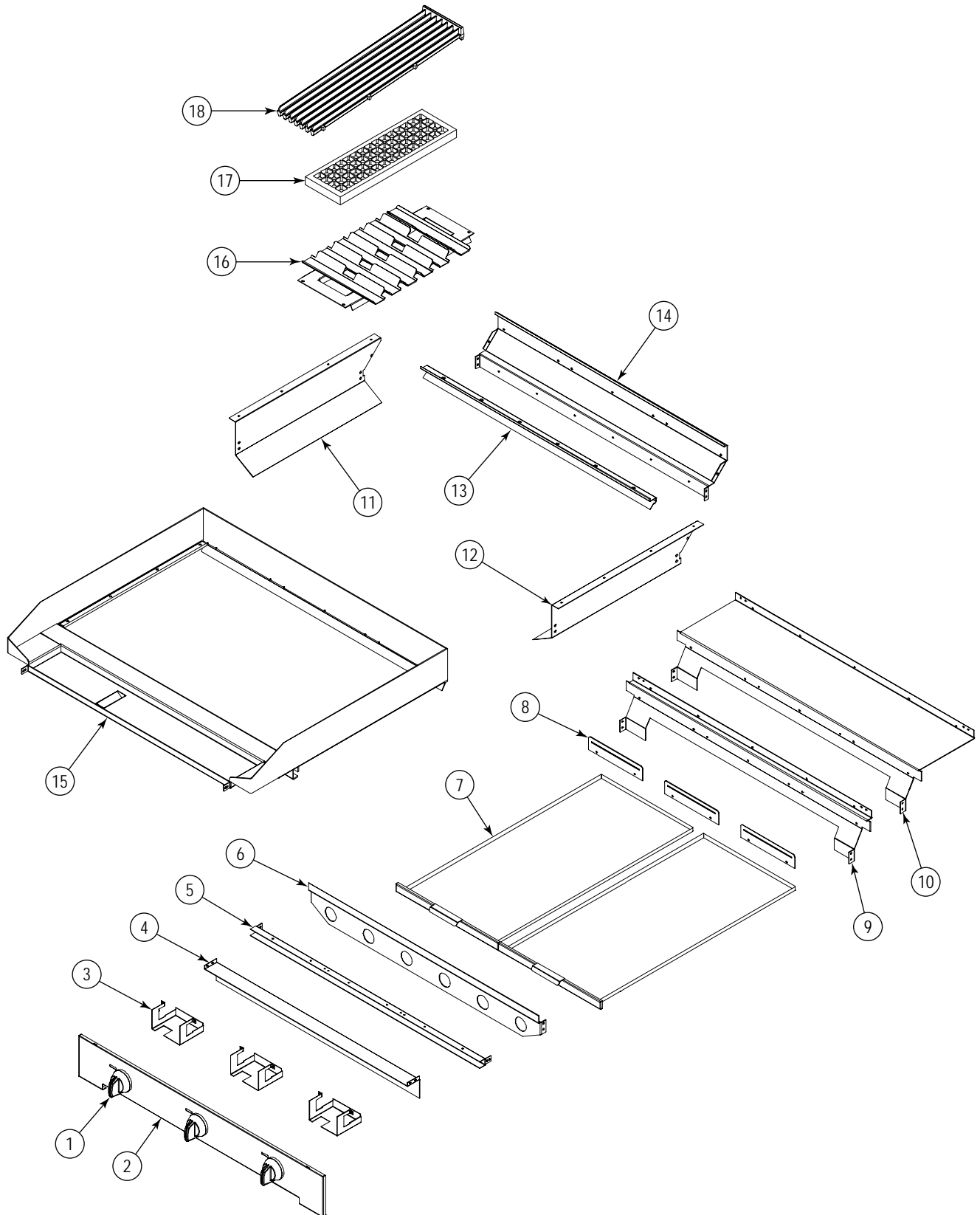

## Wood Smoker External and Structural Parts for 36", 48", 60" and 72" Models

See drawing on following page.

Key	Part Number	Qty	Description	Key	Part Number	Qty	Description
1	1188417	1	Base Assy, 36" Cntrtop Smoker	18	1187100	1	Panel, 36", 60" Smoker Box Rear
	1188416	1	Base Assy, 24" Cntrtop Smoker		1187831	1	Panel, 36", 60" Smoker Box Rear
	1188418	1	Base Assy, 60", 72" Cntrtop Smoker L. Side		1187962	2	Panel, 72" Smoker Box Rear
	1188419	1	Base Assy, 72" Cntrtop Smoker R. Side	19	1186884	2	Bracket, Mounting
	1188420	1	Base Assy, 48" Cntrtop Smoker	20	1187954	1	Trim, 60" Smoker Front Center (NOT SHOWN)
2	1187826	2	Bracket, R. Smkr Tie Down		1187815	1	Trim, 72" Smoker Front Center (NOT SHOWN)
3	1187825	2	Trim, 36", 48", 72" inside L & R Smkr Box	21	1188495	1	Hickory Wood Chunks 10lb Bag (NOT SHOWN)
	1187955	2	Trim, 60" Inside L&R Smoker Box	22	1188496	1	Mesquite Wood Chunks 10lb Bag (NOT SHOWN)
4	11887824	1	Shiled, 36" Heat Diverter	23	1188509	1	Handle, Smoker Door Pull
	1187379	2	Shield, 60", 72" Heat L & R Side	24	1188505	1	Door, 36", 60" Smoker Box
	1187827	1	Shield, 60" Heat Diverter 24" Side		1188506	1	Door, 48" Smoker Box
	1187828	1	Shield, 48" Heat Diverter		1188507	1	Door, 72" Smoker Box
5	1187821	1	Valve Panel, P36W-CCC				
	1187838	1	Valve Panel, P48W-CCCC				
	1187952	1	Valve Panel, P60W-CCCCC				
	1188410	1	Valve Panel, P72W-CCCCC				
6	1187819	2	Guide, smoker Drip Pan				
7	1187818	1	Grease Drawer Smoker W/A				
8	1187814	1	Rack, 36", 60" Wood Smoker				
	1187836	1	Rack, 48" Wood Smoker				
	1187963	2	Rack, 72" Wood Smoker				
9	1187813	1	Box W/A, 36", 60" Smoker				
	1187832	1	Box W/A, 48" Smoker				
	1187965	1	Box W/A, 72" Smoker				
10	1187807	1	Tray, 36", 60" Water/Catch				
	1187837	1	Tray, 48" Water/Catch				
	1187866	2	Tray, 72" Water/Catch				
11	1187373	1	Burner Box Bottom, 36" Smoker				
	1187111	1	Burner Box Bottom, 48" Smoker				
	1187843	1	Burner Box Bottom, 60", 72 Smoker 36" Left Side				
	1188402	1	Burner Box Bottom, 72" Smoker 36" Right Side				
12	1187372	1	PL/36 Platinum Stand				
	1187823	1	PL/48 Platinum Stand				
	1188421	1	PL/60 Platinum Stand				
	1188422	1	PL/72 Platinum Stand				
13	1187370	1	Trim, 36" Smoker Opening Finish				
	1187361	1	Trim, 48" Smoker Opening Finish				
	1187378	1	Trim, 36", 72" Smoker Opening Finish				
	1187371	1	Trim, 60" Smoker 24" Side Opening Finish				
	1188404	1	Trim, 72" Smoker 36" R. SideOpening Finish				
14	1187368	1	Trim, 36" Smoker Rear Body				
	1187369	1	Trim, 48" Smoker Rear Body				
	1187956	1	Trim, 60" Smoker Rear Body				
	1187816	2	Trim, 72" Smoker Rear Body				
15	1187367	2	Side, 35", 48", 72" Smoker L & R Body				
	1187953	2	Side, 60" Smoker L & R Body				
16	1187113	1	Diverter, 36" R Smoker Grease				
	1187114	1	Diverter, 48" R Smoker Grease				
	1187849	1	Diverter, 60", 72" Smoker 36" L. Side				
	1187377	1	Diverter, 60" Smoker 24" R. Side				
	1188403	1	Diverter, 72" Smoker 36" R. Side				
17	1187112	2	Grease Catch, LT & RT				

Figure 31

### Wood Smoker External and Structural Parts for 36", 48", 60" and 72" Models

See parts list on previous page.

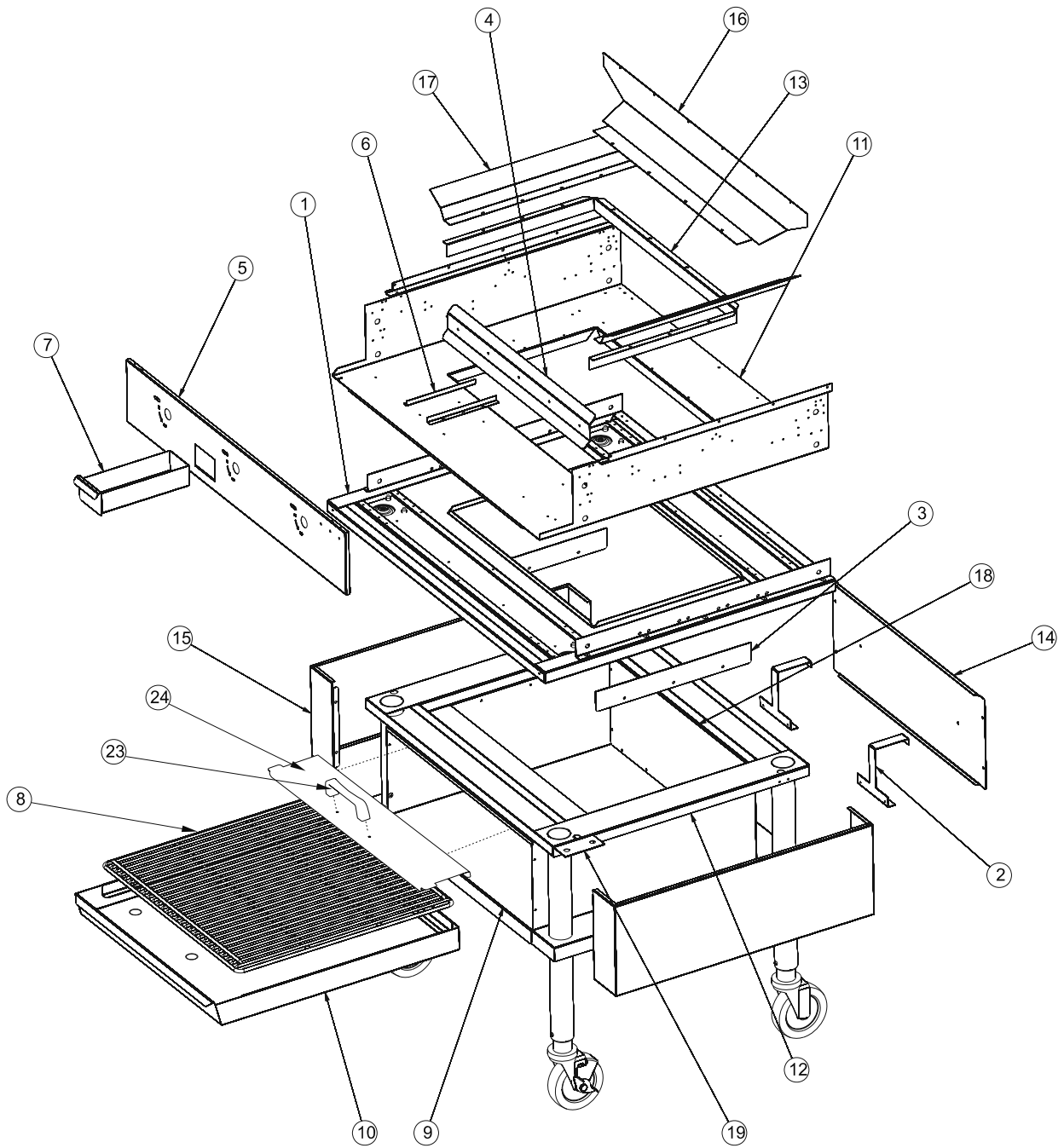
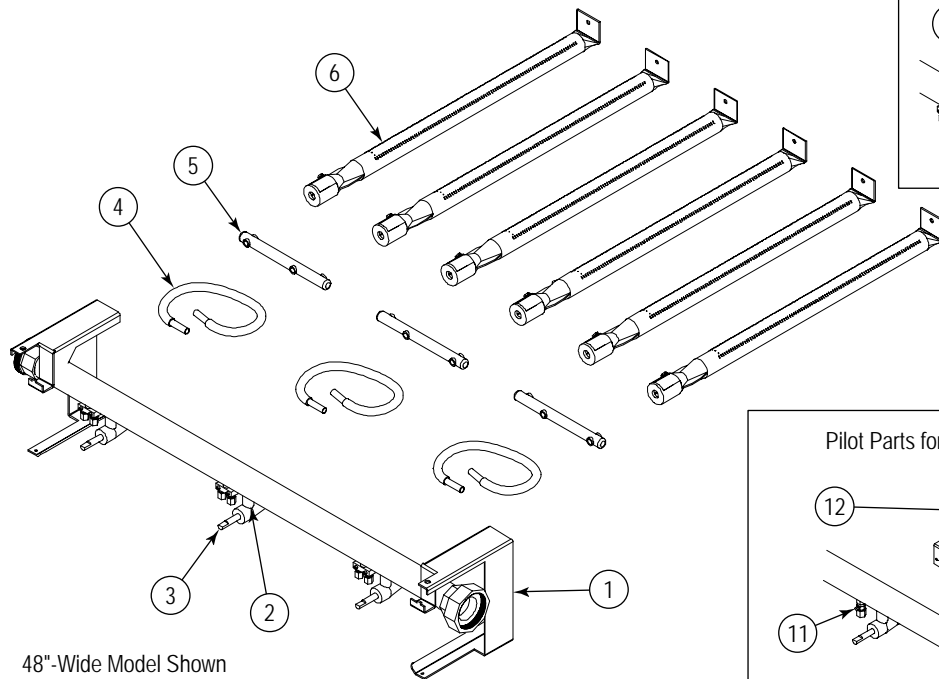

Figure 32

### Charbroiler and Standard-Griddle Gas Train Parts



48"-Wide Model Shown

Key	Part Number	Quantity*					Description
		16"	24"	32"	36**	48**	
1	1185762	1	-	-	-	-	MANIFOLD W/A, 16, CHAR/GRI SECT
	1183919	-	1	-	-	-	MANIFOLD W/A, 24, CHAR/GRI SECT
	1185761	-	-	1	-	-	MANIFOLD W/A, 32, CHAR/GRI SECT
	1183675	-	-	-	1	-	MANIFOLD W/A, 36, CHAR/GRI SECT
	1183921	-	-	-	-	1	MANIFOLD W/A, 48, CHAR/GRI SECT
2	1179222	1	2	2	3	4	NIPPLE, EXTENSION
3	1176008	1	2	2	3	4	VALVE, BURNER, NAT
4	1183503	1	2	2	3	4	TUBE, 3/8" X 9" FLEXIBLE
5	1183680	-	2	-	3	4	MANIFOLD, DUAL BURNER ORIFICE
	1185503	1	-	2	-	-	MANIFOLD, DUAL BURNER ORIFICE
**	1008748	2	4	4	6	8	ORIFICE, NAT GAS (if appliance will operate above 2000 ft, contact Southbend for appropriate orifice size)
	1008756	2	4	4	6	8	ORIFICE, PROPANE (if appliance will operate above 2000 ft, contact Southbend for appropriate orifice size)
6	1182762	2	4	4	6	8	BURNER ASSEMBLY, CHARBROILER
7	1166004	1	2	2	3	4	FITTING, DOUBLE PILOT, 3/16" TUBE
8	1184505	1	2	2	3	4	TUBE W/A, CHAR. LEFT PILOT
9	1184506	-	2	-	3	4	TUBE W/A, CHAR. RIGHT PILOT
	1185743	1	-	2	-	-	TUBE W/A, CHAR. RIGHT PILOT
10	1182821	2	4	4	6	8	BRACKET, PILOT
11	1099002	1	1	1	1	2	PILOT ADJUST
**	1184541	1	1	1	1	2	PILOT GAS TUBE
12	1183687	1	1	1	1	2	ASSEMBLY, PILOT SHIELD
13	1183681	1	1	1	1	2	BRACKET, PILOT
14	1183573	1	1	2	2	2	TUBE, RUNNER TUBE ORIFICE
15	1183584	1	1	2	2	2	FITTING, NAT 3/8 REDUCER
16	1183536	1	1	2	2	2	TUBE ASSEMBLY, PILOT RUNNER

\* Quantity of part used may depend on width of section (16", 24", 32", 36", or 48"). For 48" wide griddles, use quantities in "36"" column of this table.

\*\* Not shown on drawing.

Figure 33

**Gas Connection Parts**

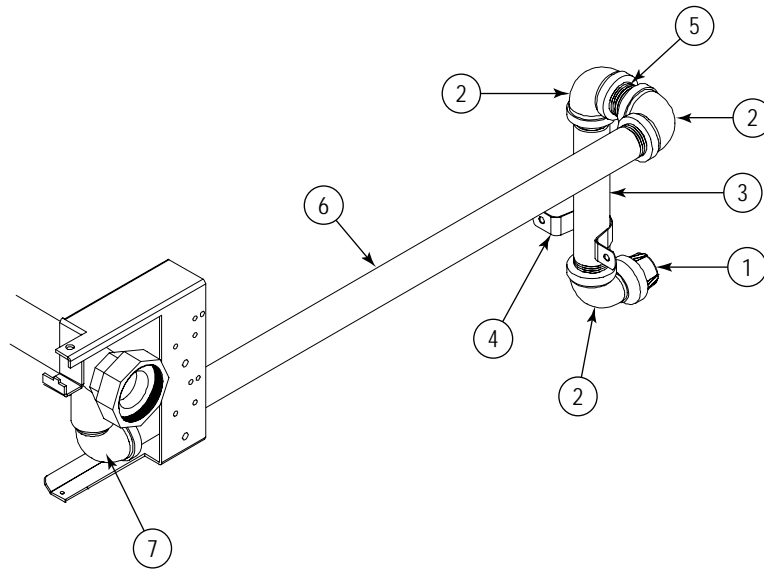

Key	Part Number	Qty	Description
1	1147005	1	1" PIPE CAP
2	1146905	2	1" 90 DEGREE ELBOW
3	1163489	1	REAR GAS STUB
4	1184777	1	STRAP, 1-1/4" PIPE
5	1146808	1	1" PIPE NIPPLE
6	1174747	1	TAIL PIPE
	1185827	1	TAIL PIPE FOR BBB MODELS
7	1146911	1	ELBOW, ST., BLK, 1" 90 DEGREE
**	4450009	*	PRESSURE REGULATOR 1-1/4" 2,500,000 BTU NAT
	4450010	*	PRESSURE REGULATOR 1-1/4" 2,500,000 BTU LP
**	1167782	*	PRESSURE REGULATOR 1" 600,000 BTU NAT
	1167783	*	PRESSURE REGULATOR 1" 600,000 BTU LP
**	4450008	*	1-1/4" GAS SHUT OFF VALVE
	4450007	*	1" GAS SHUT OFF VALVE
**	1130195	*	1" QUICK DISCONNECT, 48" FLEX HOSE
	1130194	*	1" QUICK DISCONNECT, 60" FLEX HOSE

\* Quantity varies.

\*\* Not shown on drawing.

## Griddle External and Structural Parts

See drawing on following page.

Key	Part Number	Quantity*				Description
		16"	32"	36"	48"	
1	1073497	1	2	3	3	KNOB [for thermostatic griddles]
	1189600	1	2	3	3	KNOB [for standard, non-thermostatic griddles]
2	1182156	1	2	3	3	KNOB ASM, VALVE
3	1185952	1	-	-	-	VALVE PANEL, 16C-G, SS
	1185953	1	-	-	-	VALVE PANEL, 16C-T, SS
	1185954	1	-	-	-	VALVE PANEL, 16N-G, SS
	1185955	1	-	-	-	VALVE PANEL, 16N-T, SS
	1185918	-	1	-	-	VALVE PANEL, 32A/D-GG, SS
	1185664	-	1	-	-	VALVE PANEL, 32A/D-TT, SS
	1185920	-	1	-	-	VALVE PANEL, 32C-GG, SS
	1185665	-	1	-	-	VALVE PANEL, 32C-TT, SS
	1185919	-	1	-	-	VALVE PANEL, 32N-GG, SS
	1185666	-	1	-	-	VALVE PANEL, 32N-TT, SS
	1184601	-	-	1	-	VALVE PANEL, 36A/D-GGG, SS
	1183963	-	-	1	-	VALVE PANEL, 36A/D-TTT, SS
	1184602	-	-	1	-	VALVE PANEL, 36C-GGG, SS
	1183962	-	-	1	-	VALVE PANEL, 36C-TTT, SS
	1184600	-	-	1	-	VALVE PANEL, 36N-GGG, SS
	1183961	-	-	1	-	VALVE PANEL, 36N-TTT, SS
	1184680	-	-	-	1	VALVE PANEL, 48A/D-GGG, SS
	1184674	-	-	-	1	VALVE PANEL, 48A/D-TTT, SS
	1184682	-	-	-	1	VALVE PANEL, 48C-GGG, SS
	1184676	-	-	-	1	VALVE PANEL, 48C-TTT, SS
1184684	-	-	-	1	VALVE PANEL, 48N-GGG, SS	
1184678	-	-	-	1	VALVE PANEL, 48N-TTT, SS	
4	1183696	1	1	1	1	GREASE DRAWER W/A
5	1183691	1	1	1	1	GREASE DRAWER BASE W/A
6	1184773	1	2	3	3	COVER, VALVE SHIELD
7	1185564	2	-	-	-	BURNER REST, 16 CHAR/GRI
	1185563	-	2	-	-	BURNER REST, 32 CHAR/GRI
	1183524	-	-	2	-	BURNER REST, 36 CHAR/GRI
	1183895	-	-	-	2	BURNER REST, 48 CHAR/GRI
8	1185912	1	-	-	-	SHIELD, 16" GRIDDLE HEAT
	1185589	-	1	-	-	SHIELD, 32" GRIDDLE HEAT
	1183653	-	-	1	-	SHIELD, 36" GRIDDLE HEAT
	1185387	-	-	-	1	SHIELD, 48" GRIDDLE HEAT
9	1183685	-	1	2	2	BURNER BOX DIVIDER
10	1185632	1	-	-	-	TRIM, CHAR/GRI 16 FLUE RISER
	1185631	-	1	-	-	TRIM, CHAR/GRI 32 FLUE RISER
	1183635	-	-	1	-	TRIM, CHAR/GRI 36 FLUE RISER
	1183889	-	-	-	1	TRIM, CHAR/GRI 48 FLUE RISER
11	1185946	1	-	-	-	TRIM, 42 DEEP CHAR/GRI 16 FLUE RISER
	1185671	-	1	-	-	TRIM, 42 DEEP CHAR/GRI 32 FLUE RISER
	1183590	-	-	1	-	TRIM, 42 DEEP CHAR/GRI 36 FLUE RISER
	1183892	-	-	-	1	TRIM, 42 DEEP CHAR/GRI 48 FLUE RISER
12	1146383	1	2	3	3	BOLT, HEX, 5/16-18X5LG. (thermostatic griddles only)
13	1183692	1	2	3	3	SHIELD, T'STAT BULB (thermostatic griddles only)
14	501601-B	1	-	-	-	GRIDDLE W/A, 16 STANDARD
	1185698	-	1	-	-	GRIDDLE W/A, 32 STANDARD
	1183785	-	-	1	-	GRIDDLE W/A, 36 STANDARD
	1185378	-	-	-	1	GRIDDLE W/A, 48 STANDARD
	1185887	1	-	-	-	GRIDDLE W/A, 16 T-STAT
	1185656	-	1	-	-	GRIDDLE W/A, 32 T-STAT
	1183656	-	-	1	-	GRIDDLE W/A, 36 T-STAT
1185464	-	-	-	1	GRIDDLE W/A, 48 T-STAT	
**	1189809	1	2	3	3	1.5 V IGNITOR
**	1189818	1	2	3	3	1.5 V AAA BATTERY
**	1190508	1	2	3	3	ELECTRODE 17"

\* Quantity of part used may depend on width of section (16", 32", 36", or 48").

\*\* Not shown on drawing.

Figure 34

### Griddle External and Structural Parts

See parts list on previous page.

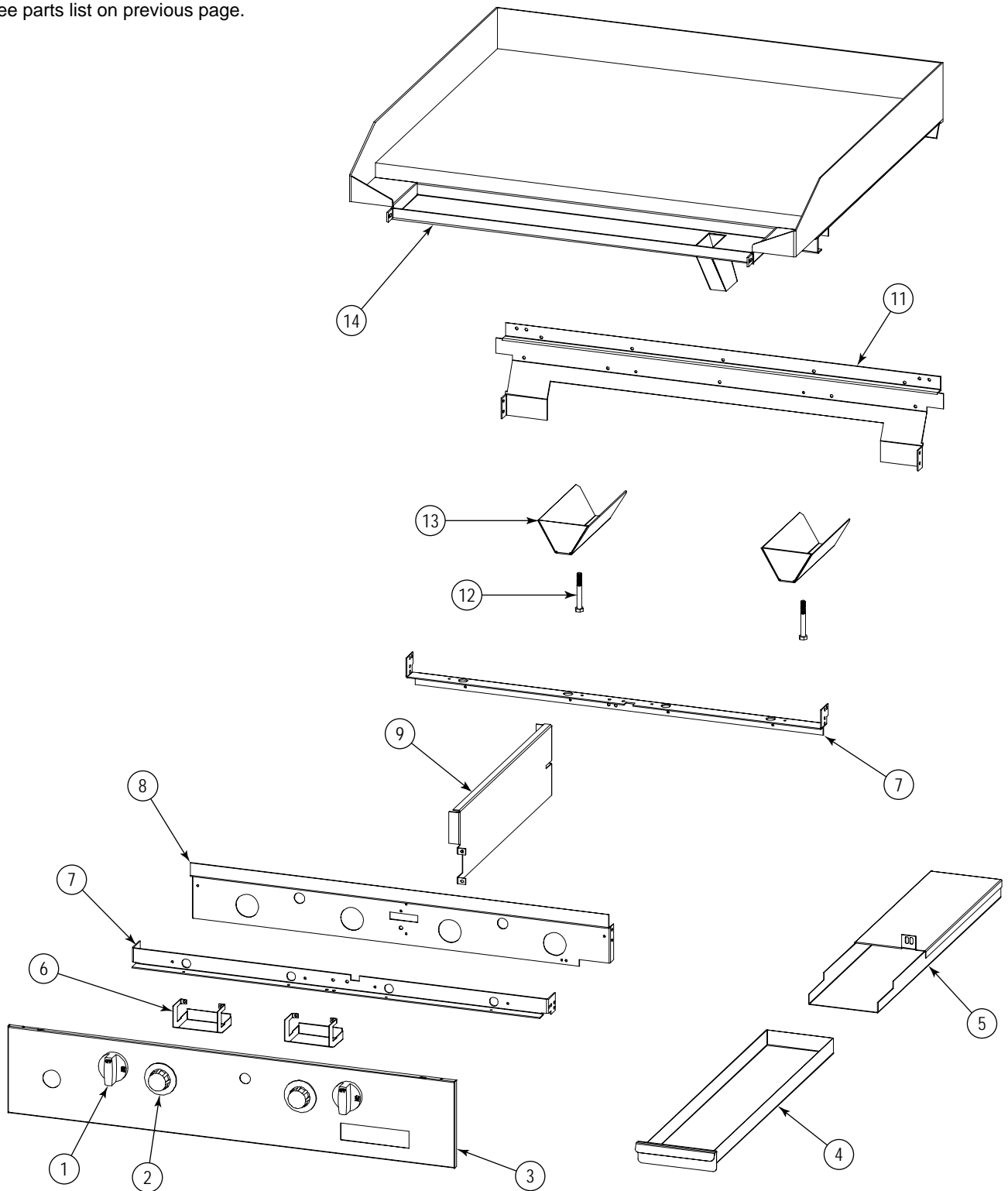

## Thermostatic Griddle Gas Train Parts

See drawing on following page.

Key	Part Number	Quantity*				Description
		16"	32"	36"	48"	
1	1185762	1	-	-	1	MANIFOLD W/A, 16, CHAR/GRI SECT
	1185761	-	1	-	1	MANIFOLD W/A, 32, CHAR/GRI SECT
	1183675	-	-	1	-	MANIFOLD W/A, 36, CHAR/GRI SECT
2	1185596	1	-	-	1	SUPPORT, 16 THERMOSTAT
	1185570	-	1	-	1	SUPPORT, 32 THERMOSTAT
	1183545	-	-	1	-	SUPPORT, 36 THERMOSTAT
3	1183549	1	1	1	2	VALVE, 200K BURNER
4	1185539	1	1	-	2	TUBE, SAFETY VALVE
	1184391	-	-	1	-	TUBE, SAFETY VALVE
5	1185536	1	-	-	1	SAFETY VALVE
	1185537	-	1	1	1	SAFETY VALVE
6	1185538	1	1	1	2	MANIFOLD BOX
7	1160008	1	2	2	3	ELBOW, BRASS
8	1185594	1	1	-	2	TUBE, LEFT ON/OFF GAS
	1184394	-	-	1	-	TUBE, LEFT ON/OFF GAS
**	1184395	-	-	1	-	TUBE, MIDDLE ON/OFF GAS
9	1185595	-	1	-	1	TUBE, RIGHT ON/OFF GAS
	1184396	-	-	1	-	TUBE, RIGHT ON/OFF GAS
10	1182553	1	2	3	3	SNAP ACTION GRIDDLE THERMOSTAT
11	1183503	1	2	3	3	TUBE, 3/8" X 9" FLEXIBLE
12	1185503	1	2	-	3	MANIFOLD, DUAL BURNER ORIFICE
	1183680	-	-	3	-	MANIFOLD, DUAL BURNER ORIFICE
**	1008748	2	4	6	6	ORIFICE, NAT GAS (if appliance will operate above 2000 ft, contact Southbend for appropriate orifice size)
	1008756	2	4	6	6	ORIFICE, PROPANE (if appliance will operate above 2000 ft, contact Southbend for appropriate orifice size)
13	1182762	2	4	6	6	BURNER ASSEMBLY, CHARBROILER
14	1185675	1	1	-	2	TUBE, T-GRID LT PILOT ADJUST
	1184393	-	-	1	-	TUBE, T-GRID LT PILOT ADJUST
15	1164085	1	1	1	2	VALVE ASM, PILOT
16	1185829	1	1	1	2	TUBE, T-GRID RT PILOT ADJUST
	1181084	-	-	1	-	TUBE, T-GRID RT PILOT ADJUST
17	1183687	1	1	1	2	ASSEMBLY, PILOT
18	1185651	1	1	1	2	BRACKET, PILOT
19	1185652	1	1	1	2	BRACKET, PILOT SIDE
20	1182580	1	1	1	2	THERMOCOUPLE, 24 IN
21	1183573	1	2	2	3	TUBE, RUNNER TUBE ORIFICE
22	1183536	1	2	2	3	TUBE ASSEMBLY, PILOT RUNNER
**	1189809	1	2	3	3	1.5 V IGNITOR
**	1189818	1	2	3	3	1.5 V AAA BATTERY
**	1190508	1	2	3	3	ELECTRODE 17"

\* Quantity of part used may depend on width of section (16", 32", 36", or 48").

\*\* Not shown on drawing.



Figure 35

### Thermostatic Griddle Gas Train Parts

See parts list on previous page.

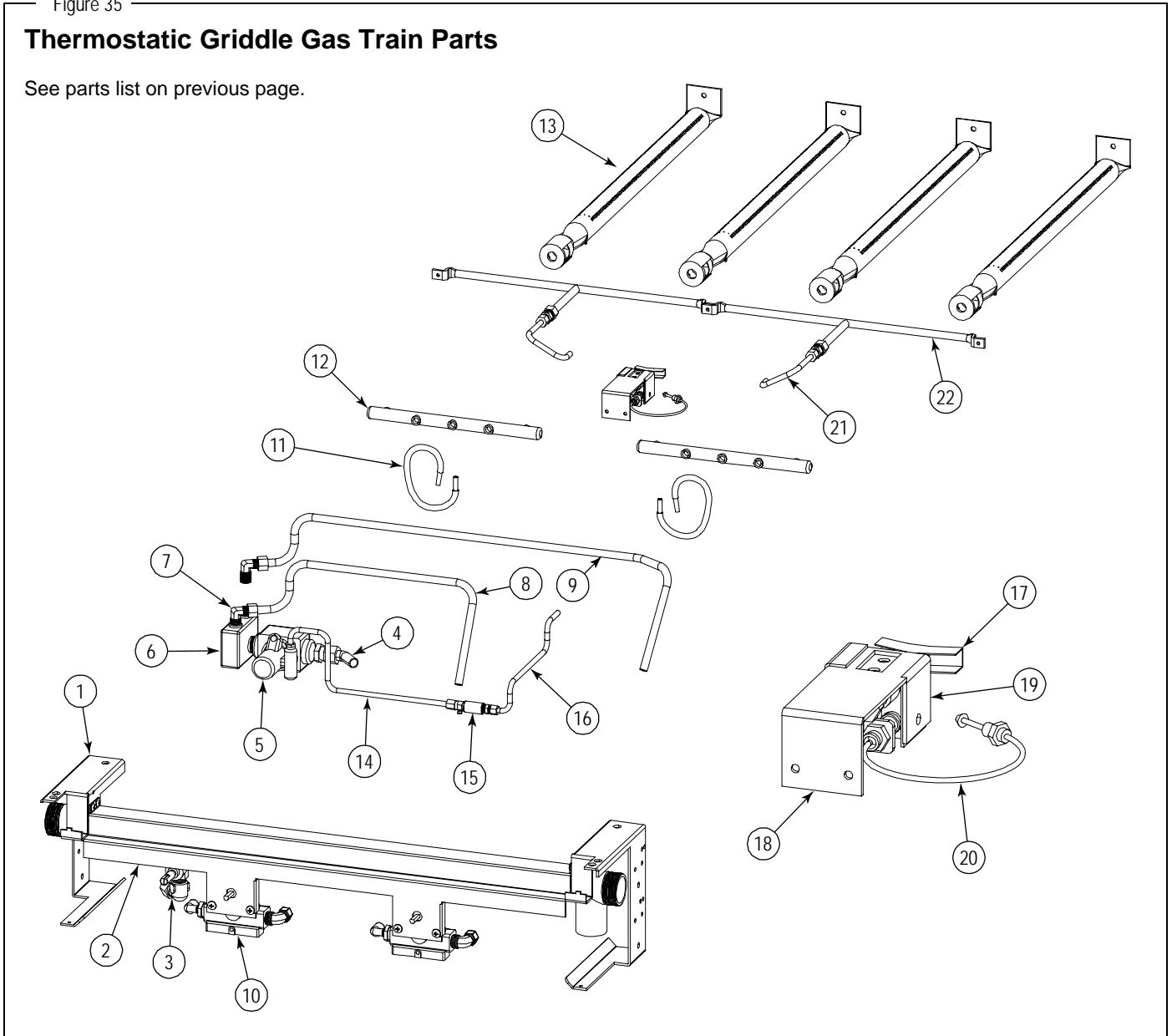

## Uniform Hot-Top Parts

See drawing on following page.

Key	Part Number	Quantity*			Description
		16"	32"	36"	
1	1189600	1	2	3	KNOB
2	1185766	1	-	-	VALVE PANEL, 16C-H, SS
	1185951	1	-	-	VALVE PANEL, 16N-H, SS
	1185758	-	1	-	VALVE PANEL, 32A/D-HH, SS
	1185759	-	1	-	VALVE PANEL, 32C-HH, SS
	1185760	-	1	-	VALVE PANEL, 32N-HH, SS
	1184611	-	-	1	VALVE PANEL, 36A/D-HHH, SS
	1184612	-	-	1	VALVE PANEL, 36C-HHH, SS
	1184613	-	-	1	VALVE PANEL, 36N-HHH, SS
3	1184546	-	-	6	BRACKET, ORIFICE 12", BURNER REST
	1185564	2	4	-	BRACKET, ORIFICE 16"
4	1184551	-	1	2	COVER, BATTERY CENTER
5	1183505	-	-	3	BURNER BOX BOTTOM, 12
	1183506	1	2	-	BURNER BOX BOTTOM, 16
6	1183563	-	1	2	TRIM, CENTER
7	1184545	-	1	2	COVER, HOT TOP DIVIDER REAR
8	1185739	1	2	-	SHIELD, 32 HOT TOP HEAT
	1184547	-	-	3	SHIELD, 36 HOT TOP HEAT
9	1184546	-	-	3	BAFFLE, 12" BURNER REST
	1185826	1	2	-	BAFFLE, 16" HOT TOP
10	1183887	1	-	-	TRIM, HOT TOP 16 FLUE RISER
	1185737	-	1	-	TRIM, HOT TOP 32 FLUE RISER
	1184544	-	-	1	TRIM, HOT TOP 36 FLUE RISER
**	1183899	1	-	-	TRIM, HOT TOP 42 DEEP 16 FLUE RISER
	1185738	-	1	-	TRIM, HOT TOP 42 DEEP 32 FLUE RISER
	1184566	-	-	1	TRIM, HOT TOP 42 DEEP 32 FLUE RISER
11	1019601	1	2	-	PLATE, UNIFORM HEATED TOP
	1183515	-	-	3	PLATE, UNIFORM HEATED TOP
12	1185763	1	-	-	MANIFOLD ASM, 16 UNIFORM H/TOP
	1185736	-	-	-	MANIFOLD ASM, 32 UNIFORM H/TOP
	1183952	-	-	1	MANIFOLD ASM, 36 UNIFORM H/TOP
13	1179222	1	2	3	NIPPLE, EXTENSION
14	1176008	1	2	3	VALVE, BURNER, NAT
15	1183503	1	2	3	TUBE, 3/8" X 9" FLEXIBLE
16	1185503	1	2	-	MANIFOLD, 32" DUAL BURNER ORIFICE
	1183680	-	-	3	MANIFOLD, 36" DUAL BURNER ORIFICE
**	1008750	2	4	6	ORIFICE, NAT GAS (if appliance will operate above 2000 ft, contact Southbend for appropriate orifice size)
	1008756	2	4	6	ORIFICE, PROPANE (if appliance will operate above 2000 ft, contact Southbend for appropriate orifice size)
17	1182762	2	4	6	BURNER ASSEMBLY, CHARBROILER
18	1166004	1	2	3	FITTING, DOUBLE PILOT, 3/16" TUBE
19	1184505	1	2	3	TUBE W/A, CHAR. LEFT PILOT
20	1184506	1	2	3	TUBE W/A, CHAR. RIGHT PILOT
21	1187594	2	4	6	BRACKET, PILOT
**	1189810	1	2	3	1.5 V IGNITOR 2-POSITION
**	1189818	1	2	3	1.5 V AAA BATTERY
**	1190507	2	4	6	ELECTRODE 25"

\* Quantity of part used may depend on width of section (16", 32", or 36").

\*\* Not shown on drawing.

Figure 36

### Uniform Hot-Top Parts

See parts list on previous page.

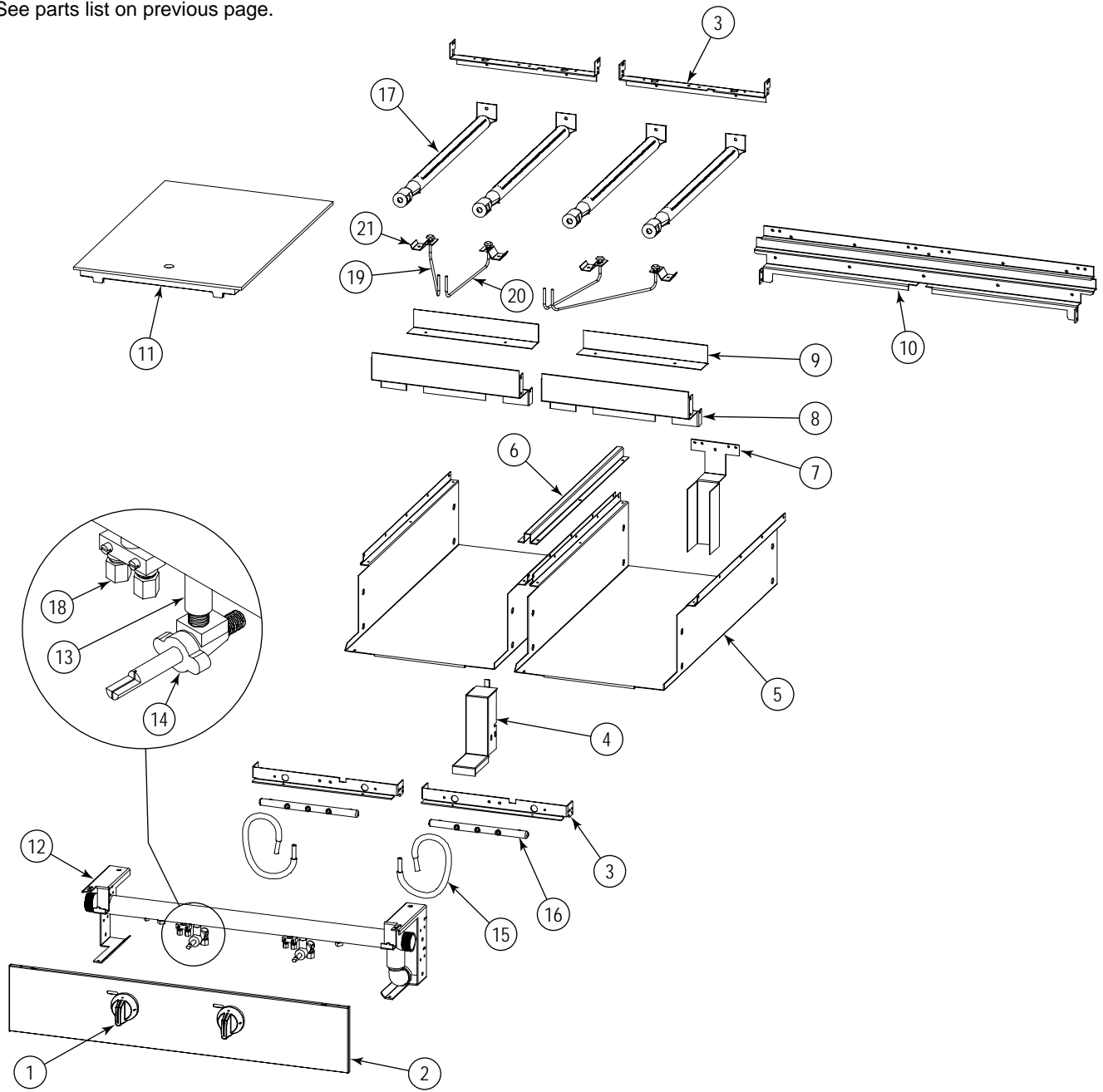

## Graduated-Hot-Top Parts

See drawing on following page.

Key	Part Number	Qty	Description
1	1189600	1	KNOB
2	1185940	1	VALVE PANEL, 32A/D-GRAD, SS (oven base)
	1185942	1	VALVE PANEL, 32C-GRAD, SS (cabinet base)
	1185941	1	VALVE PANEL, 32N-GRAD, SS (modular-countertop base)
3	1183560	1	TRIM, 32 FLUE RISER
4	1183588	1	TRIM, 42 DEEP 32 FLUE RISER
5	1185659	2	BURNER REST, GRADUATED
6	1183959	2	BRACKET, BURNER HOLD DOWN
7	1185658	1	SHIELD, GRADUATED BURNER
8	1018998	2	PLATE, GRADUATED HEAT TOP
9	1018997	1	PS, GRIDDLE, CSTIR, RING, GRAD.
10	1018996	1	PS, GRIDDLE, CSTIR, LID.GRAD.
11	1185943	1	MANIFOLD W/A, GRADUATED H/TOP
12	1176016	1	BURNER VALVE, NAT
*	1006425	1	ORIFICE, NAT GAS (if appliance will operate above 2000 ft, contact Southbend for appropriate orifice size)
	1006443	1	ORIFICE, PROPANE (if appliance will operate above 2000 ft, contact Southbend for appropriate orifice size)
13	1884	1	HOT TOP BRNR ASM
14	1160293	1	BAFFLE, TOP BURNER AIR
15	1099002	1	PILOT ADJUST
16	1164199	1	TUBE, PILOT
17	1183964	1	BRACKET, PILOT ASSEMBLY
18	1038099	1	ASSEMBLY, PILOT
*	1189809	1	1.5 V IGNITOR
*	1189818	1	1.5 V AAA BATTERY
*	1190507	1	ELECTRODE 25"
* Not shown on drawing.			

Figure 37

### Graduated-Hot-Top Parts

See parts list on previous page.

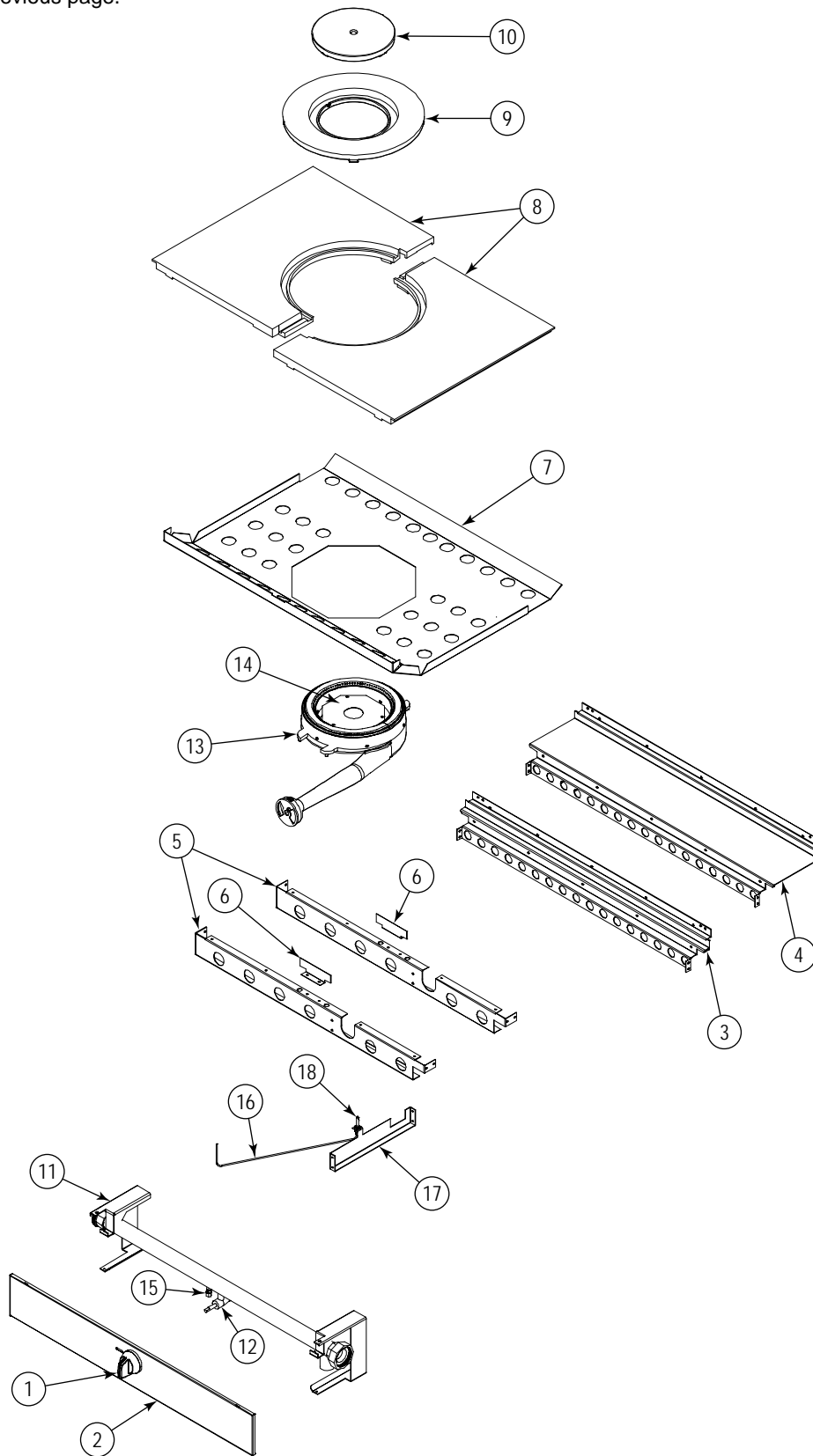

## Oven Base Parts

See drawing on following page.

Key	Part Number	Qty	Description
1	1180776	1	OVEN BOTTOMFLAME
2	1180528	2	RACK_GUIDE CO BASE
3	6660	8	CLIP, RACK SUPPORT
*	1173545CP	1	OVEN RACK (for standard oven)
	1179920	1	OVEN RACK (for convection oven)
4	1186598	1	POWER SWITCH
5	1186599	1	ON/OFF FAN SWITCH (for convection oven)
6	1174749	1	KNOB
*	1189744	1	THERMOSTAT
7	1188733	1	CONTROL PANEL W/A (for units with electronic ignition)
	1189808	1	CONTROL PANEL W/A (for units with standing pilot)
8	1187304	1	ASSEMBLY, OVEN DOOR (for units built on or after October 23, 2006)
*	1189786	1	LEFT DOOR HINGE ASSEMBLY
*	1189788	1	RIGHT DOOR HINGE ASSEMBLY
*	1183575	1	KICK PANEL
9	1186547	1	OVEN DOOR SPRING (for units built on or after October 30, 2005)
10	1189817	1	CHAIN ASSEMBLY (for units built on or after May 12, 2008)
11	1183551	1	BRACKET ASSEMBLY, ROLLER ASM
12	1183618	1	PULLEY BRACKET
13	1166129	1	DOOR CHAIN PULLEY
14	1165783	1	DOOR SPROCKET BUSHING
15	1179710	1	BLOWER MOTOR SPACER
16	1183683	1	DOOR PULLEY PIN
17	1183574	1	1/8" DIA X 1" COTTER PIN ZINC
18	1186539	1	DOOR SWITCH BRACKET ASSEMBLY
19	1189812	1	TUBE, OVEN GAS SUPPLY
20	1188768	1	COMBINATION VALVE (for units with a standing pilot)
21	1185533	1	SOLENOID VALVE ASM, 120V/60 (for units with electronic ignition)
22	1187477	1	TUBE, OVEN BURNER (for units with a standing pilot)
23	1183633	1	SOLENOID TO ORIFICE TUBE (for units with electronic ignition)
24	1183568	1	BRACKET, ORIFICE
*	1008730	1	ORIFICE, NAT GAS (if appliance will operate above 2000 ft, contact Southbend for appropriate orifice size)
*	1008748	1	ORIFICE, PROPANE (if appliance will operate above 2000 ft, contact Southbend for appropriate orifice size)
25	1187994	1	BURNER ASSEMBLY (for units with a standing pilot)
26	1183567	1	BURNER ASSEMBLY (for units with electronic ignition)
27	1187672	1	PILOT TUBE (for units with a standing pilot)
28	1185851	1	PILOT TUBE (for units with electronic ignition)
29	1168263	1	PILOT
30	1186218	1	PILOT SHIELD (for units with a standing pilot)
31	1183504	1	PILOT SHIELD BRACKET (for units with electronic ignition)
*	1182154	1	THERMOPILE (for units with a standing pilot)
32	1168262	1	SWITCH, FLAME (for units with electronic ignition)
33	1165708	1	FLM SW MNT BRKT (for units with electronic ignition)
34	1164809	1	SPARK MODULE (for units with electronic ignition)
*	1184997	1	SPARK MODULE SHIELD (for units with electronic ignition)
35	1164807	1	ELECTRODE (for units with electronic ignition)
36	1183518	1	KNOB, ON/OFF (for units with electronic ignition)
37	1176099	1	VALVE, BURNER (for units with electronic ignition)
38	1006299	1	ELBOW, 1/2CC X 3/8M F (for units with electronic ignition)
* Not shown on drawing.			

Figure 38

**Oven Base Parts**

See parts list on previous page.

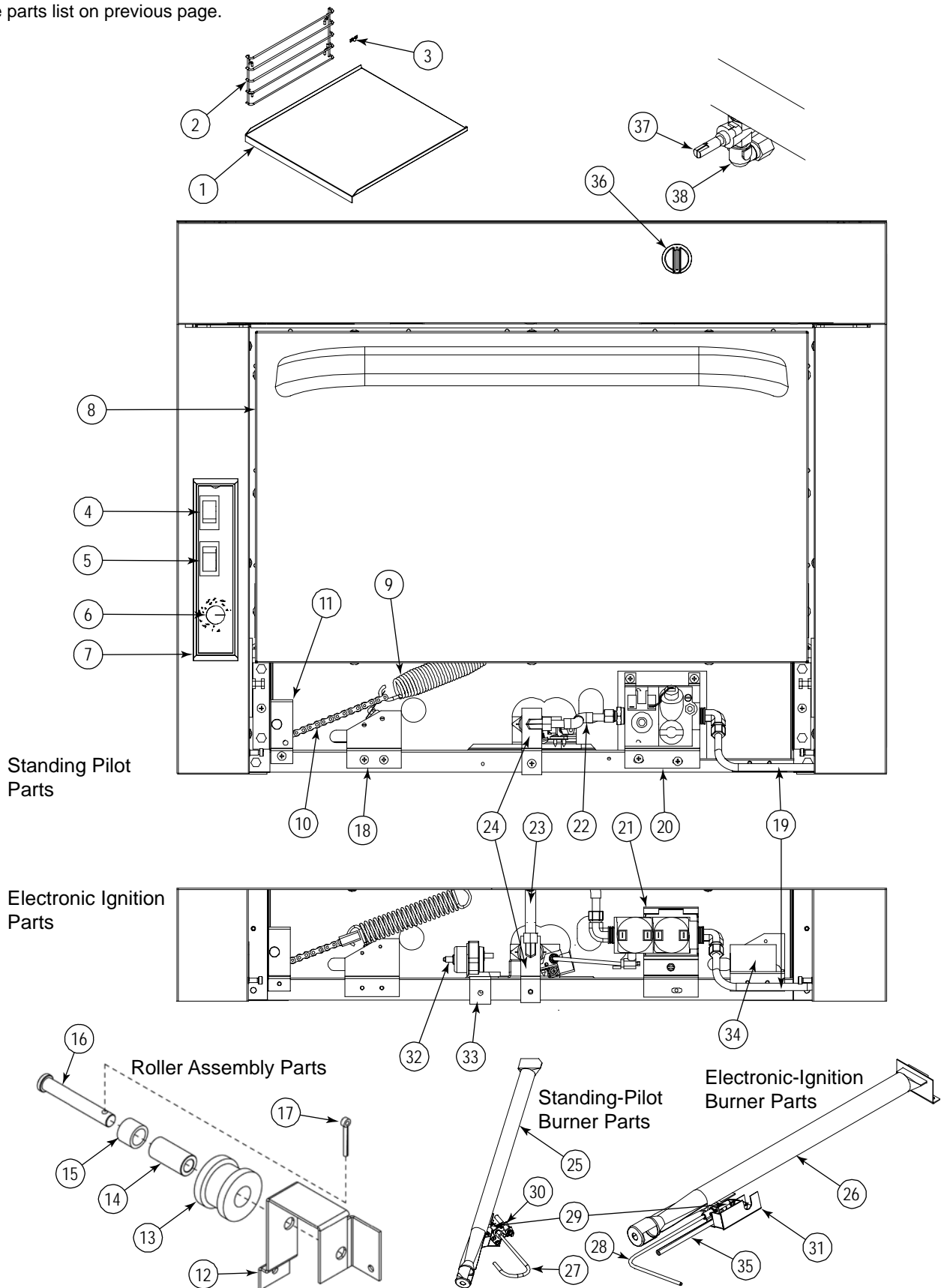
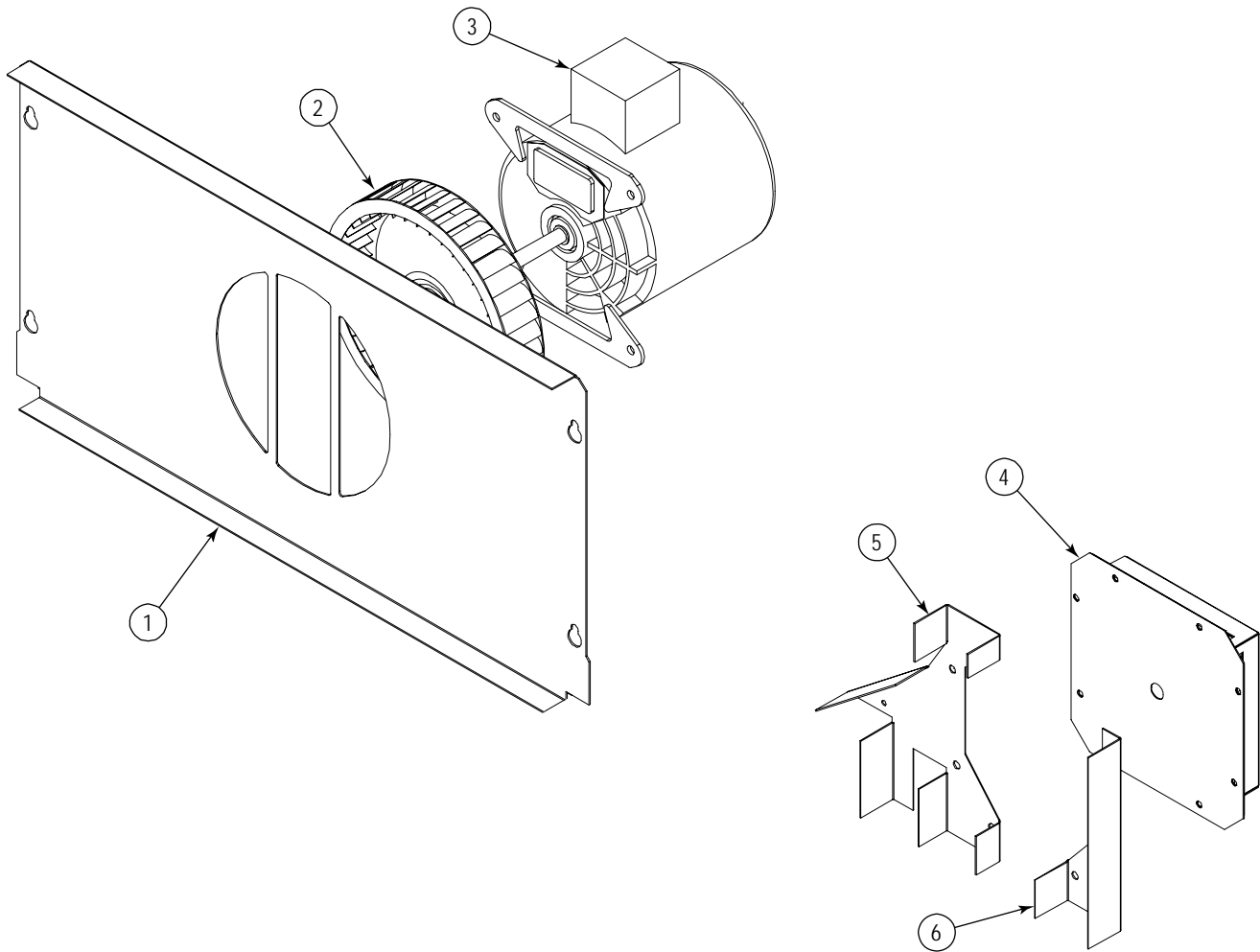

Figure 39

**Convection Oven Blower Parts**



Key	Part Number	Qty	Description
1	1180834	1	OVEN BAFFLE CO
2	1177581	1	BLOWER WHEEL ASSEMBLY
3	1188523	1	MOTOR, 1/2 HP, 115 VOLT
4	1180821	1	POCKET W/A, BLOWER, 500 SERIES
5	1181747	1	SHIELD, RT BLOWER, 500 SERIES
6	1181748	1	SHIELD, LT BLOWER, 500 SERIES



Figure 40

**Modular-Countertop Base Parts**

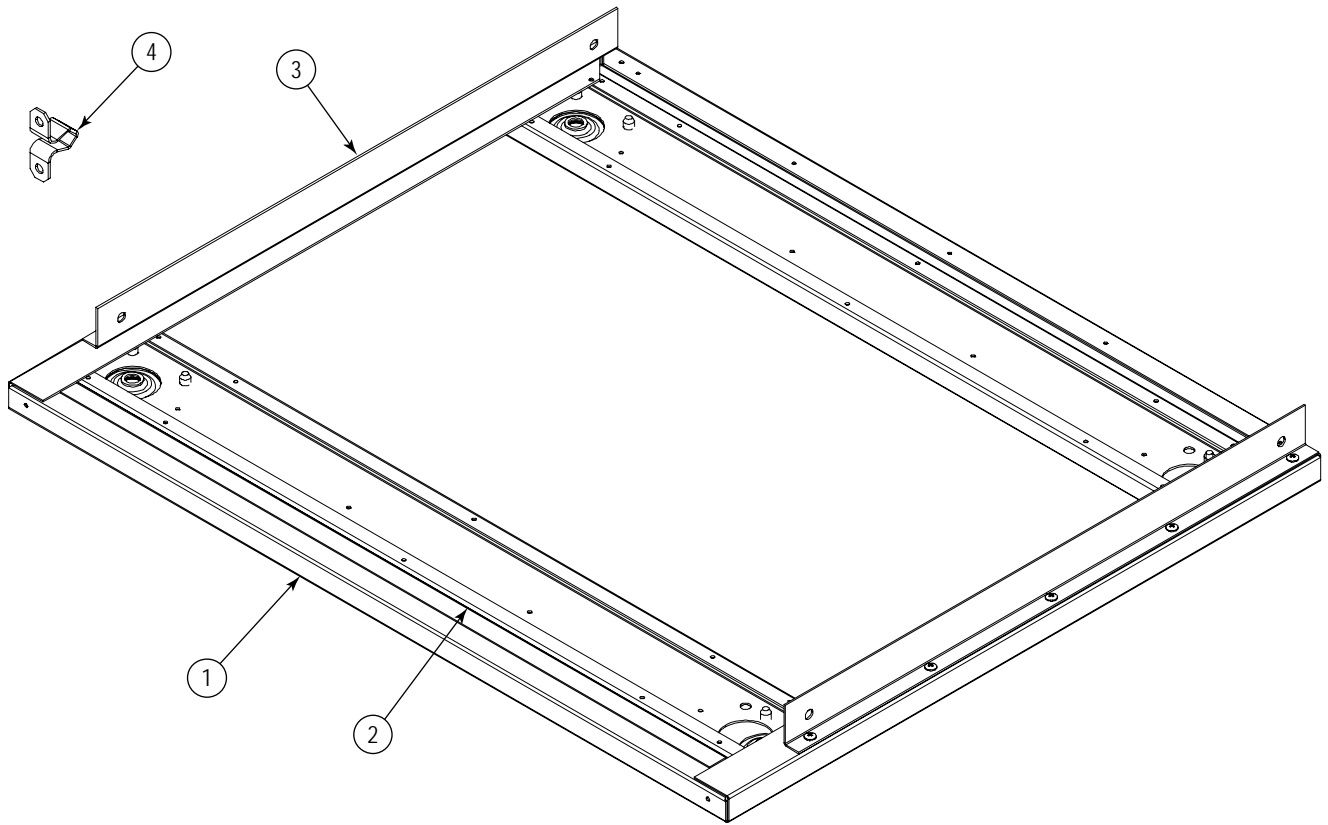

Key	Part Number	Qty	Description
1	1183863	1	BASE. 12 COUNTERTOP
	1183862	1	BASE. 16 COUNTERTOP
	1183859	1	BASE. 24 COUNTERTOP
	1183576	1	BASE. 32 COUNTERTOP
	1183523	1	BASE. 36 COUNTERTOP
	1185418	1	BASE. 48 COUNTERTOP
2	1183861	2	STIFFENER, 12 BASE
	1183860	2	STIFFENER, 16 BASE
	1183858	2	STIFFENER, 24 BASE
	1183580	2	STIFFENER, 32 BASE
	1183579	2	STIFFENER, 36 BASE
	1185413	2	STIFFENER, 48 BASE
3	1183640	2	RETAINER, MODULAR TOP
4	1164132	2	STRIKER (for valve panel)
*	1164133	2	CATCH (for valve panel)
* Not shown on drawing.			

## Cabinet-Base Parts

See drawing on following page.

Key	Part Number	Quantity*						Description
		12"	16"	24"	32"	36"	48"	
1	1184954	1	-	-	-	-	-	CABINET LINING ASM, 12" LT FT
	1185496	-	1	-	-	-	-	CABINET LINING ASM, 16" LT FT
	1184952	-	-	1	-	-	2	CABINET LINING ASM, 24" LT FT
	1183595	-	-	-	1	-	-	CABINET LINING ASM, 32" LT FT
	1183598	-	-	-	-	1	-	CABINET LINING ASM, 36" LT FT
2	1184955	1	-	-	-	-	-	CABINET LINING ASM, 12" RT FT
	1185497	-	1	-	-	-	-	CABINET LINING ASM, 16" RT FT
	1184953	-	-	1	-	-	2	CABINET LINING ASM, 24" RT FT
	1183596	-	-	-	1	-	-	CABINET LINING ASM, 32" RT FT
	1183599	-	-	-	-	1	-	CABINET LINING ASM, 36" RT FT
3	1183875	1	-	-	-	-	-	CABINET LINING, 12" BOTTOM
	1183874	-	1	-	-	-	-	CABINET LINING, 16" BOTTOM
	1183873	-	-	1	-	-	2	CABINET LINING, 24" BOTTOM
	1183600	-	-	-	-	1	-	CABINET LINING, 32"-36" BOTTOM
4	1183563	-	-	-	1	1	-	TRIM, CENTER
5	1183866	1	-	-	-	-	-	CABINET LINING, 12" LEFT
	1183865	-	1	-	-	-	-	CABINET LINING, 16" LEFT
	1183864	-	-	1	-	-	2	CABINET LINING, 24" LEFT
	1183586	-	-	-	-	1	-	CABINET LINING, 32"-36" LEFT
6	1183869	1	-	-	-	-	-	CABINET LINING, 12" RIGHT
	1183868	-	1	-	-	-	-	CABINET LINING, 16" RIGHT
	1183867	-	-	1	-	-	2	CABINET LINING, 24" RIGHT
	1183587	-	-	-	-	1	-	CABINET LINING, 32"-36" RIGHT
7	1183872	1	-	-	-	-	-	CABINET LINING, 12" BACK
	1183871	-	1	-	-	-	-	CABINET LINING, 16" BACK
	1183870	-	-	1	-	-	2	CABINET LINING, 24" BACK
	1183594	-	-	-	-	1	-	CABINET LINING, 32"-36" BACK
**	1183983	-	1	1	1	1	2	HINGE ASSEMBLY, UPPER RIGHT
**	1183984	-	1	1	1	1	2	HINGE ASSEMBLY, LOWER RIGHT
**	1183985	1	1	1	1	1	2	HINGE ASSEMBLY, UPPER LEFT
**	1183986	1	1	1	1	1	2	HINGE ASSEMBLY, LOWER LEFT

\* Quantity of part used may depend on width of section (12", 16", 24", 32", 36", or 48").

\*\* Not shown on drawing.

Figure 41

### Cabinet-Base Parts

See parts list on previous page.

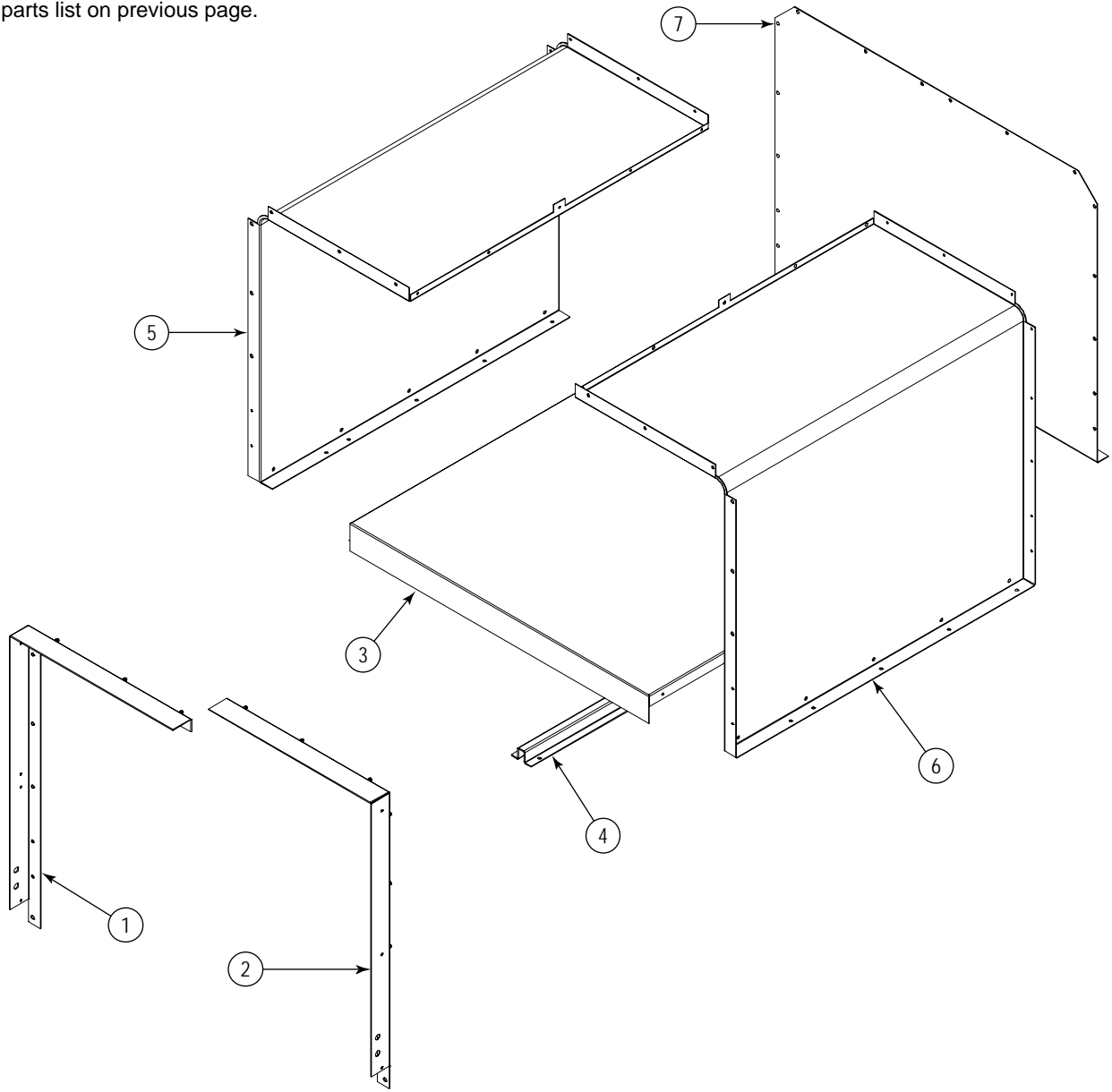

## Flue Riser Parts

See drawing on following page.

For continuous flue risers spanning multiple sections, or sloped enclosures, contact Southbend.

Key	Part Number	Qty	Description
1	1183617	1	FLUE BOX ASSEMBLY (for models with an oven base)
2	1183526	1	BRACKET, 36 DEEP LT FLUE RISER
	1183527	1	BRACKET, 36 DEEP RT FLUE RISER
3	1183528	1	BRACKET, 42 DEEP LT FLUE RISER
	1183529	1	BRACKET, 42 DEEP RT FLUE RISER
4	1183791	1	SPLASHER, 5" X 12" [height x width]
	1183792	1	SPLASHER, 5" X 16"
	1183793	1	SPLASHER, 5" X 24"
	1183794	1	SPLASHER, 5" X 32"
	1183530	1	SPLASHER, 5" X 36"
	1183795	1	SPLASHER, 5" X 48"
	1183801	1	SPLASHER, 24" X 12"
	1183802	1	SPLASHER, 24" X 16"
	1183803	1	SPLASHER, 24" X 24"
	1183804	1	SPLASHER, 24" X 32"
	1183851	1	SPLASHER, 24" X 36"
	1183805	1	SPLASHER, 24" X 48"
	1183811	1	SPLASHER, 36" X 12"
	1183812	1	SPLASHER, 36" X 16"
	1183813	1	SPLASHER, 36" X 24"
	1183814	1	SPLASHER, 36" X 32"
	1183852	1	SPLASHER, 36" X 36"
1183815	1	SPLASHER, 36" X 48"	
5	1183821	1	SHIELD, 5" X 12" WALL AZ
	1184785	1	SHIELD, 5" X 12" WALL SS
	1183822	1	SHIELD, 5" X 16" WALL AZ
	1185860	1	SHIELD, 5" X 16" WALL SS
	1183823	1	SHIELD, 5" X 24" WALL AZ
	1184786	1	SHIELD, 5" X 24" WALL SS
	1183824	1	SHIELD, 5" X 32" WALL AZ
	1185859	1	SHIELD, 5" X 32" WALL SS
	1183684	1	SHIELD, 5" X 36" WALL AZ
	1184791	1	SHIELD, 5" X 36" WALL SS
	1183825	1	SHIELD, 5" X 48" WALL AZ
	1184792	1	SHIELD, 5" X 48" WALL SS
	1183831	1	SHIELD, 24" X 12" WALL AZ
	1184793	1	SHIELD, 24" X 12" WALL SS
	1183832	1	SHIELD, 24" X 16" WALL AZ
	1185862	1	SHIELD, 24" X 16" WALL SS
	1183833	1	SHIELD, 24" X 24" WALL AZ
	1184794	1	SHIELD, 24" X 24" WALL SS
	1183834	1	SHIELD, 24" X 32" WALL AZ
	1185861	1	SHIELD, 24" X 32" WALL SS
	1183853	1	SHIELD, 24" X 36" WALL AZ
1184795	1	SHIELD, 24" X 36" WALL SS	
1183835	1	SHIELD, 24" X 48" WALL AZ	
1184796	1	SHIELD, 24" X 48" WALL SS	

Table continues on next page.

<b>Flue Riser Parts (continued)</b>			
Key	Part Number	Qty	Description
5	1183841	1	SHIELD, 36" X 12" WALL AZ
	1184797	1	SHIELD, 36" X 12" WALL SS
	1183842	1	SHIELD, 36" X 16" WALL AZ
	1185864	1	SHIELD, 36" X 16" WALL SS
	1183843	1	SHIELD, 36" X 24" WALL AZ
	1184798	1	SHIELD, 36" X 24" WALL SS
	1183844	1	SHIELD, 36" X 32" WALL AZ
	1185863	1	SHIELD, 36" X 32" WALL SS
	1183854	1	SHIELD, 36" X 36" WALL AZ
	1184799	1	SHIELD, 36" X 36" WALL SS
	1183845	1	SHIELD, 36" X 48" WALL AZ
	1184900	1	SHIELD, 36" X 48" WALL SS

Figure 42

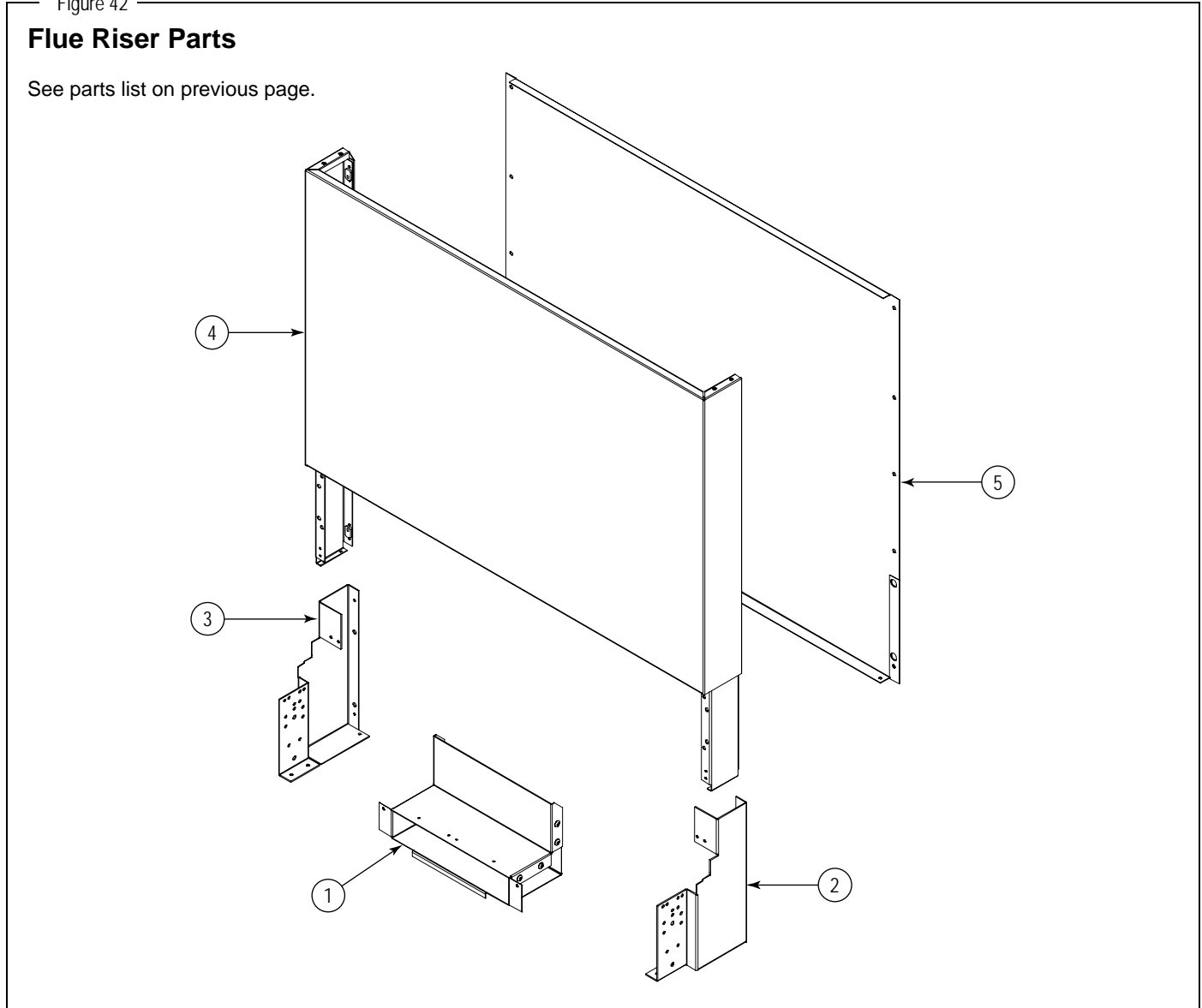
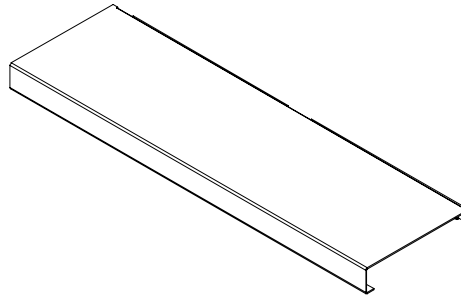

Figure 43

**Front-Rail Parts**

For custom front rails, or continuous rails spanning multiple sections, contact Southbend.

Models	Part Number	Description
P12_-B	1184718	FRONT RAIL, 9-1/4"
P16_-H, P16_-X	1185856	FRONT RAIL, 9-1/4"
P16_-C, P16_-G, P16_-T	1185947	FRONT RAIL, 9-1/4"
P32_-BBB, P32_-BBB-SU, P32_-GRAD, P32_-HH, P32_-XH, P32_-XH-RE, P32_-XX	1184589	FRONT RAIL, 9-1/4"
P32_-CC, P32_-GG, P32_-TT	1185677	FRONT RAIL, 9-1/4"
P36_-BBB, P36_-BBB-SU, P36_-GRAD, P36_-XXX	1187065	FRONT RAIL, 9-1/4"
P36_-CCC	1184699	FRONT RAIL, 9-1/4"
P36_-GGG, P36_-TTT	1187069	FRONT RAIL, 9-1/4"
P36_-HHH	1184630	FRONT RAIL, 9-1/4"
P48_-BBBB	1184721	FRONT RAIL, 9-1/4"
P48_-CCCC, P48_-GGG, P48_-TTT	1184698	FRONT RAIL, 9-1/4"

**Shelf Parts**

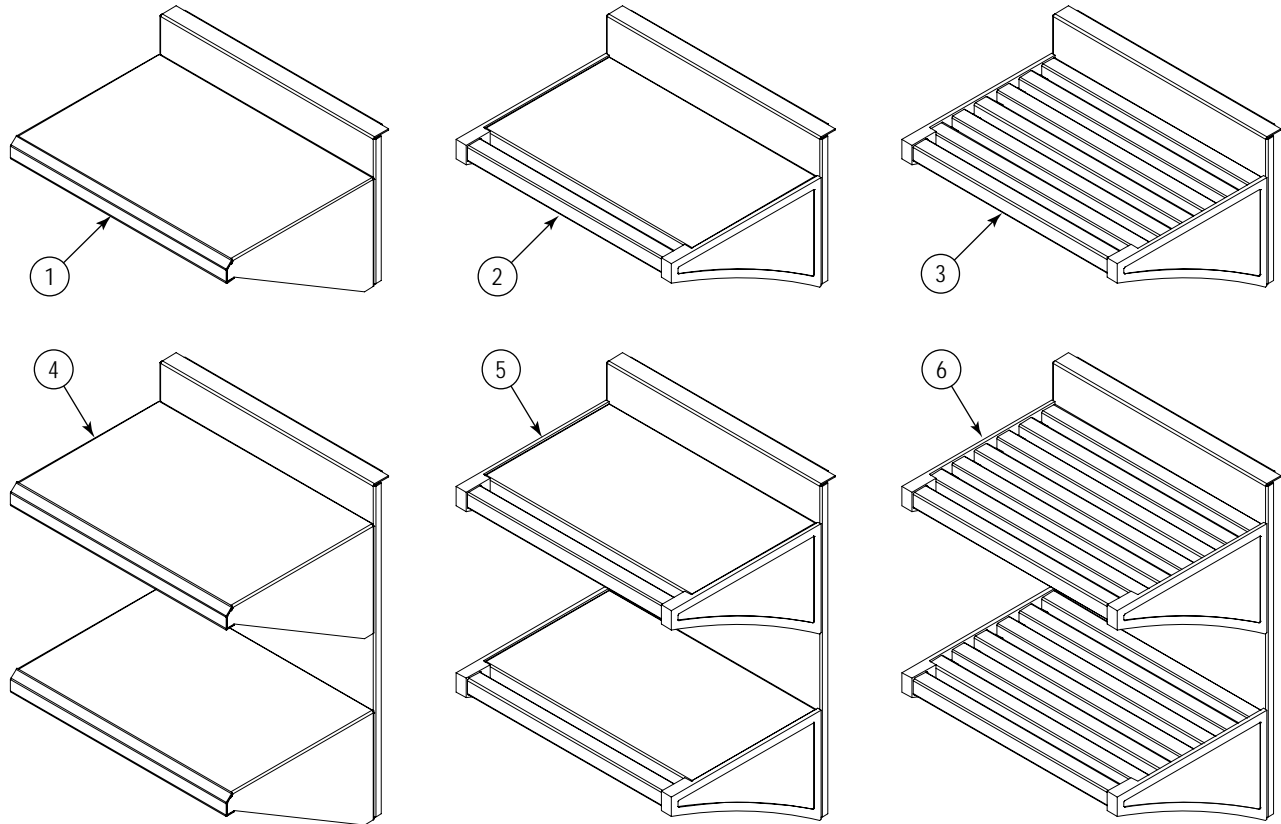

Key	Part Number	Description
1	1185870	SINGLE SOLID SHELF ASM, 12"
	1185686	SINGLE SOLID SHELF ASM, 16"
	1185685	SINGLE SOLID SHELF ASM, 32"
	1185925	SINGLE SOLID SHELF ASM, 36"
	1185687	SINGLE SOLID SHELF ASM, 48"
2	1185874	SINGLE TRAY SHELF ASM, 12"
	1185875	SINGLE TRAY SHELF ASM, 16"
	1184751	SINGLE TRAY SHELF ASM, 32"
	1188669	SINGLE TRAY SHELF ASM, 36"
	1185876	SINGLE TRAY SHELF ASM, 48"
3	1185880	SINGLE TUBE SHELF ASM, 12"
	1185881	SINGLE TUBE SHELF ASM, 16"
	1184755	SINGLE TUBE SHELF ASM, 32"
	1184754	SINGLE TUBE SHELF ASM, 36"
	1185882	SINGLE TUBE SHELF ASM, 48"
4	1185871	DOUBLE SOLID SHELF ASM, 12"
	1185689	DOUBLE SOLID SHELF ASM, 16"
	1185688	DOUBLE SOLID SHELF ASM, 32"
	1185928	DOUBLE SOLID SHELF ASM, 36"
	1185690	DOUBLE SOLID SHELF ASM, 48"
5	1185877	DOUBLE TRAY SHELF ASM, 12"
	1185878	DOUBLE TRAY SHELF ASM, 16"
	1184753	DOUBLE TRAY SHELF ASM, 32"
	1184752	DOUBLE TRAY SHELF ASM, 36"
	1185879	DOUBLE TRAY SHELF ASM, 48"
6	1185883	DOUBLE TUBE SHELF ASM, 12"
	1185884	DOUBLE TUBE SHELF ASM, 16"
	1184757	DOUBLE TUBE SHELF ASM, 32"
	1184756	DOUBLE TUBE SHELF ASM, 36"
	1185885	DOUBLE TUBE SHELF ASM, 48"

<b>Side Panel and Battery-Assembly Parts</b>	
Part Number	Description
1189760	BODY SIDE, RIGHT
1189759	BODY SIDE, LEFT
1189765	TRIM, 32 CABINET, RT
1189755	TRIM, 32 CABINET, LT
1189766	TRIM, 32 CABINET OPEN, RT
1189756	TRIM, 32 CABINET OPEN, LT
1189761	TRIM, 32 OVEN, RT
1188775	TRIM, 32 OVEN, LT
1189762	TRIM, 32 OVEN OPEN, RT
1188749	TRIM, 32 OVEN OPEN, LT
1189767	TRIM, 36 CABINET, RT
1189757	TRIM, 36 CABINET, LT
1189768	TRIM, 36 CABINET OPEN, RT
1189758	TRIM, 36 CABINET OPEN, LT
1189763	TRIM, 36 OVEN, RT
1188757	TRIM, 36 OVEN, LT
1189764	TRIM, 36 OVEN OPEN, RT
1188762	TRIM, 36 OVEN OPEN, LT
1183665	TRIM, FRONT, CAB TO CAB
1183664	TRIM, FRONT, CAB TO 32 CAB
1188783	TRIM, FRONT, CAB TO 32 OVEN
1188794	TRIM, FRONT, CAB TO 36 OVEN
1184568	TRIM, FRONT, 32 OVEN TO CAB
1184569	TRIM, FRONT, 32 OVEN TO 32 CAB
1184571	TRIM, FRONT, 32 OVEN TO 36 CAB
1188784	TRIM, FRONT, 32 OVEN TO 32 OVEN
1189742	TRIM, FRONT, 32 OVEN TO 36 OVEN
1183666	TRIM, FRONT, 36 CAB TO CAB
1189741	TRIM, FRONT, 36 CAB TO 32 OVEN
1183669	TRIM, FRONT, 36 CAB TO 36 CAB
1188793	TRIM, FRONT, 36 CAB TO 36 OVEN
1183661	TRIM, FRONT, 36 OVEN TO CAB
1183660	TRIM, FRONT, 36 OVEN TO 32 CAB
1183658	TRIM, FRONT, 36 OVEN TO 36 CAB
1189743	TRIM, FRONT, 36 OVEN TO 32 OVEN
1188792	TRIM, FRONT, 36 OVEN TO 36 OVEN



Figure 44

**Leg and Caster Parts**

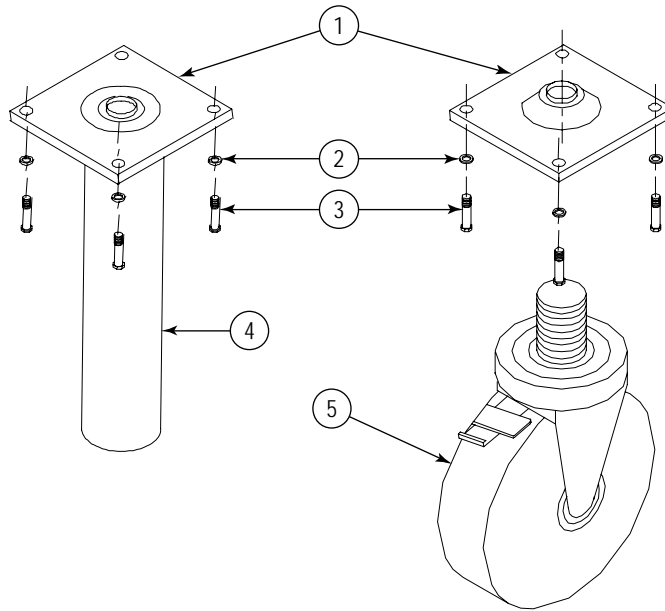

Key	Part Number	Qty	Description
1	1172650	4	LEG PAD (3/4 X 10 HOLE)
2	1146500	16	1/4 LOCK WASHER
3	1146201	16	1/4 X 30 X 3/4 HEX HEAD
4	1174260	1	LEG PACKAGE (set of four legs, not including bolts, leg pads, or lock washers)
*	1174262	1	EARTHQUAKE LEGS SS (set of four)
5	1174265	1	CASTER PACKAGE (two casters with brake and two without brake; does not include bolts, lock washers, or leg pads)
* Not shown in drawing.			

Notes:

## PLATINUM SERIES SECTIONAL RANGE

Notes:

# Platinum Series

## SECTIONAL RANGE



Commercial Food Equipment Service Association



A product with the Southbend name incorporates the best in durability and low maintenance. We all recognize, however, that replacement parts and occasional professional service may be necessary to extend the useful life of this appliance. When service is needed, contact a Southbend Authorized Service Agency, or your dealer. To avoid confusion, always refer to the model number, serial number, and type of your appliance.



Southbend  
 1100 Old Honeycutt Road, Fuquay-Varina, NC 27526  
[www.southbendnc.com](http://www.southbendnc.com)