



IMPORTANT FOR FUTURE REFERENCE

Please complete this information and retain this manual for the life of the equipment:

Model #: _____

Serial #: _____

Date Purchased: _____

Owner's Manual

Ultimate Restaurant Ranges

Model 400 Series



Model 4365A



Model 4601DD-2RR

⚠ WARNING

Improper installation, adjustment, alteration, service, or maintenance can cause property damage, injury, or death. Read installation, operation, and maintenance instructions thoroughly before installing or servicing this equipment.

1100 Old Honeycutt Road, Fuquay-Varina, NC 27526 USA • www.southbendnc.com



SAFETY PRECAUTIONS

Before installing and operating this equipment, be sure everyone involved in its operation is fully trained and aware of precautions. Accidents and problems can be caused by failure to follow fundamental rules and precautions.

The following symbols, found throughout this manual, alert you to potentially dangerous conditions to the operator, service personnel, or to the equipment.



DANGER

This symbol warns of immediate hazards that will result in severe injury or death.



WARNING

This symbol refers to a potential hazard or unsafe practice that could result in injury or death.



CAUTION

This symbol refers to a potential hazard or unsafe practice that could result in injury, product damage, or property damage.

NOTICE

This symbol refers to information that needs special attention or must be fully understood, even though not dangerous.



WARNING FIRE HAZARD

FOR YOUR SAFETY

Do not store or use gasoline or other flammable vapors and liquids in the vicinity of cooking appliances.

Keep area around cooking appliances free and clear of combustibles.

Purchaser of equipment must post in a prominent location detailed instructions to be followed in the event the operator smells gas. Obtain the instructions from the local gas supplier.



WARNING BURN HAZARD

Contact with hot surfaces will cause severe burns. Always use caution when operating cooking appliances.



WARNING EXPLOSION AND ASPHYXIATION HAZARD

In the event a gas odor is detected, shut down equipment at the main gas shut-off valve and immediately call the emergency phone number of your gas supplier.

Improper ventilation can result in headaches, drowsiness, nausea, and could result in death. Do not obstruct the flow of combustion and ventilation air to and from cooking appliances.



WARNING ELECTRIC SHOCK HAZARD

For appliances that use electric power, disconnect the power to the appliance before cleaning. Do not remove panels that require tools to remove. Disconnect power before opening kick panel below oven.

NOTICE

This appliance is intended for commercial use, and is only for professional use. It shall be used by trained, qualified people.

Warranty will be void if service work is performed by other than a qualified technician, or if other than genuine Southbend replacement parts are installed.

Give this Owner's Manual and important papers to the proper authority to retain for future reference.

INTRODUCTION

Congratulations! You have purchased one of the finest pieces of heavy-duty commercial cooking equipment on the market.

You will find that your new equipment, like all Southbend equipment, has been designed and manufactured to meet the toughest standards in the industry. Each piece of Southbend equipment is carefully engineered and designs are verified through laboratory tests and field installations. With proper care and field maintenance, you will experience years of reliable, trouble-free operation. For best results, read this manual carefully.

RETAIN THIS MANUAL FOR FUTURE REFERENCE.

This manual is divided into six sections:

- Introduction 3
- Specifications..... 4
- Operation..... 8
- Cleaning & Maintenance 13
- Installation 15
- Service..... 21

The serial plate is located on the inside surface of the kick panel (see Figure 1 below).

Read these instructions carefully before attempting installation. Installation and initial startup should be performed by a qualified installer. Unless the installation instructions for this product are followed by a qualified service technician (a person experienced in and knowledgeable with the installation of commercial gas and/or electric cooking equipment) then the terms and conditions on the Manufacturer’s Limited Warranty will be rendered void and no warranty of any kind shall apply.

In the event you have questions concerning the installation, use, care, or service of the product, contact:

Southbend Technical Service
 1100 Old Honeycutt Road
 Fuquay-Varina, North Carolina 27526 USA
www.southbendnc.com

Figure 1

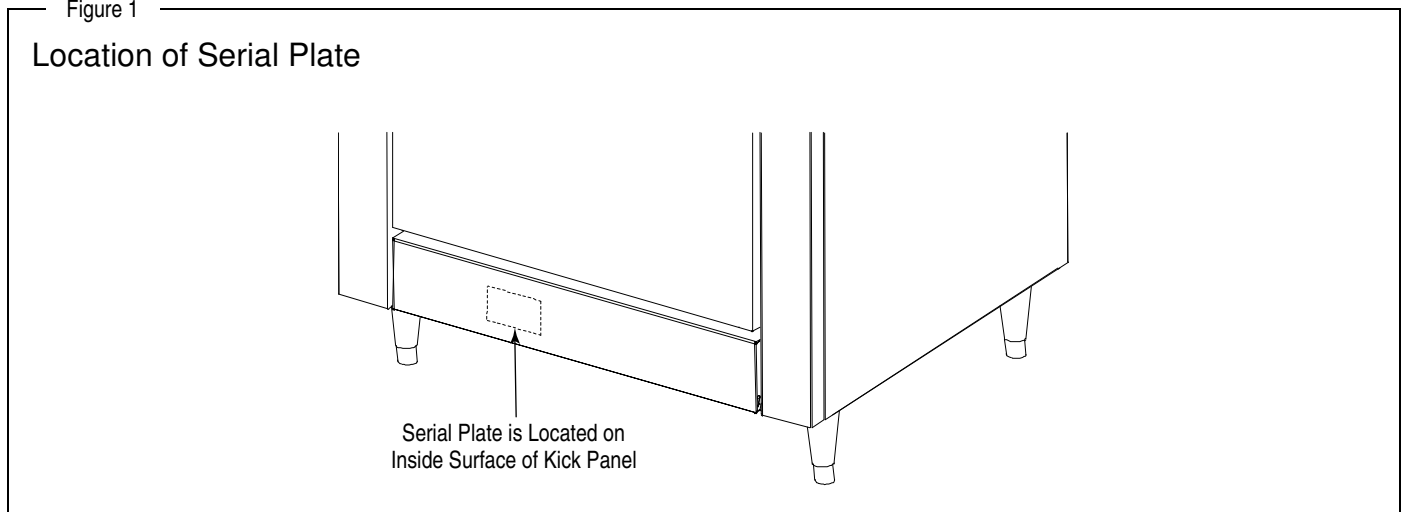

SPECIFICATIONS

NOTICE

Local codes regarding installation vary greatly from one area to another. The National Fire Protection Association, Inc., states in its NFPA 96 latest edition that local codes are the “authority having jurisdiction” when it comes to installation requirements for equipment. Therefore, installations should comply with all local codes.

Southbend reserves the right to change specifications and product design without notice. Such revisions do not entitle the buyer to corresponding changes, additions, or replacements for previously purchased equipment.

Southbend appliances are intended for commercial use only, not for household use.

The installation must conform with local codes, or in the absence of local codes, with the *National Fuel Gas Code, ANSI Z223.1, Natural Gas Installation Code, CAN/CGA-B149.1*, or the *Propane Installation Code CAN/CGA-B149.2*, as applicable, including:

1. The appliance and its individual shutoff valve must be disconnected from the gas supply piping system during any pressure testing of that system at test pressures in excess of 1/2 psi (3.45 kPa).
2. The appliance must be isolated from the gas supply piping system by closing its individual manual shutoff valve during any pressure testing of the gas supply piping system at test pressures equal to or less than 1/2 psi (3.45 kPa).

CLEARANCES

WARNING

MINIMUM CLEARANCES FROM COMBUSTIBLE CONSTRUCTION

There must be adequate clearance between ranges and combustible construction. Clearance must also be provided for servicing and for operation.

Minimum Clearances for ranges with ovens:

	Standard Oven	Convection Oven	Double Oven Base
Sides	10 inches	10 inches	10 inches
Back	10 inches	10 inches	10 inches
Floor	zero	zero	zero

Do NOT install charbroilers next to combustible materials.

Ranges are suitable for installation on combustible floors.

Adequate clearance must be provided in the aisle and at the side and rear to allow the door to open sufficiently to permit the removal of the racks and for serviceability.

On ranges with a convection-type oven, a minimum of 2 inches clearance must be allowed behind the motor and the rear non-combustible enclosure. Care must be taken to provide adequate air circulation to prevent the motor from overheating.

ELECTRICAL REQUIREMENTS

Ranges with a convection oven, electric oven, or infrared broiler require connection to a supply of electricity. The appliance, when installed, must be electrically grounded in accordance with local codes, or in the absence of local codes, with the *National Electric Code, ANSI/NFPA 70*, or the *Canadian Electrical Code, CSA C22.2*, as applicable. An electrical diagram is located on the rear of the range.

The range may be furnished with one or two power cords (one for each oven), each with a standard 115V, 60Hz, single-phase prong plug. Some ranges instead have terminal connections. See the serial plate for maximum amperage requirements.

GAS REQUIREMENTS

The total BTU gas requirement for the range varies depending on the ordered options. The gas requirement and type of gas the range is configured for (natural gas or propane) is stated on the serial plate.

A 3/4" female NPT gas connection is located on the rear of the range (see Figure 2).

The serial plate is located inside the oven kick panel (see Figure 1). The serial plate indicates the type of gas the range is equipped to burn, and the total gas supply requirement (in BTUs). All Southbend equipment is adjusted at the factory.

These models are design-certified for operation on natural or propane gases. A kit for conversion to a different type of gas is available from Southbend.

For natural gas, the regulator is set to 4" W.C. (0.99 kPa). For propane gas, it is set to 10" W.C. (2.48 kPa). If applicable, the vent line from the gas appliance pressure regulator shall be installed to the outdoors in accordance with local codes, or in the absence of local codes, with the applicable national codes.

This appliance should be connected ONLY to the type of gas for which it is equipped.

An adequate gas supply is imperative. Undersized or low pressure lines will restrict the volume of gas required for satisfactory performance. A 1/8" pressure tap is located on the manifold to measure the manifold pressure.

An adequate gas supply line to the range should be no smaller than the inside diameter of the pipe from the range to which it is connected.

Purge the supply line to clean out dust, dirt, or other foreign matter before connecting the line to the range.

All pipe joints and connections must be tested thoroughly for gas leaks. Use only soapy water for testing on all gases. NEVER use an open flame to check for gas leaks. All connections must be checked for leaks after the range has been put into operation. Test pressure should not exceed 14" W.C. (3.47 kPa).

DIMENSIONS

The dimensions of the restaurant range are shown in Figure 2 below and on the next page.

Figure 2

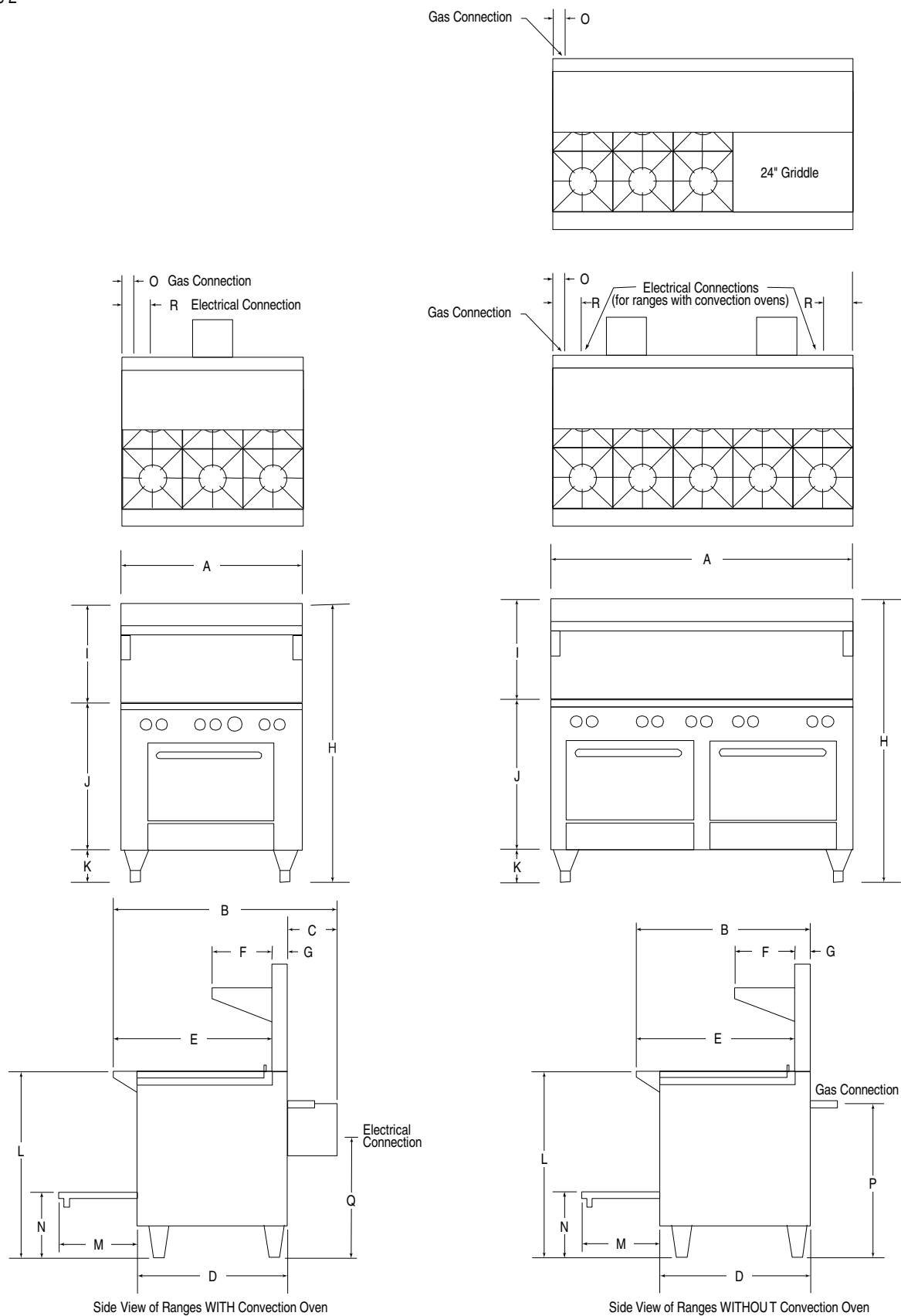

EXTERIOR DIMENSIONS

Model Number	Exterior Dimensions in Inches and (Millimeters)											Cook Top Height L	Door Depth M	Oven Bottom N
	A	B	C	D	E	F	G	H	I	J	K			
424...	24.5" (622)	36" (914)	-	31.25" (794)	33" (838)	11" (279)	2.75" (70)	59.5" (1511)	22.5" (587)	31.0" (787)	6" (152)	37.0" (914)	-	-
436... with convection oven	36.5" (927)	45.25" (1149)	10" (254)	31.25" (794)	33" (838)	11" (279)	2.75" (70)	59.5" (1511)	22.5" (587)	31.0" (787)	6" (152)	37.0" (914)	15.5" (394)	13" (318)
436... with standard oven	36.5" (927)	36" (914)	-	31.25" (794)	33" (838)	11" (279)	2.75" (70)	59.5" (1511)	22.5" (587)	31.0" (787)	6" (152)	37.0" (914)	15.5" (394)	13" (318)
448... with convection oven	48.5" (1232)	45.25" (1149)	10" (254)	31.25" (794)	33" (838)	11" (279)	2.75" (70)	59.5" (1511)	22.5" (587)	31.0" (787)	6" (152)	37.0" (914)	15.5" (394)	13" (318)
448... with standard oven	48.5" (1232)	36" (914)	-	31.25" (794)	33" (838)	11" (279)	2.75" (70)	59.5" (1511)	22.5" (587)	31.0" (787)	6" (152)	37.0" (914)	15.5" (394)	13" (318)
460... with convection oven(s)	60.75" (1543)	45.25" (1149)	10" (254)	31.25" (794)	33" (838)	11" (279)	2.75" (70)	59.5" (1511)	22.5" (587)	31.0" (787)	6" (152)	37.0" (914)	15.5" (394)	13" (318)
460... with standard oven(s)	60.75" (1543)	36" (914)	-	31.25" (794)	33" (838)	11" (279)	2.75" (70)	59.5" (1511)	22.5" (587)	31.0" (787)	6" (152)	37.0" (914)	15.5" (394)	13" (318)

Dimensions O & P: Gas connection is on rear of range and is 3.25" (82mm) from left side and 30.25" (768mm) above the floor.
 Dimensions Q & R: Electric connection is on rear of range and is 6" (152mm) from left side and 24" (610mm) above the floor. Ranges with dual ovens have two electric connections with the second connection 6" (152mm) from right side.

VENTILATION

⚠ WARNING

Improper ventilation can result in personal injury or death. Ventilation which fails to properly remove flue products can cause headaches, drowsiness, nausea, or could result in death.

All ranges must be installed in such a manner that the flow of combustion and ventilation air are not obstructed. Provisions for adequate air supply must be provided. Do not obstruct the front of the range at the top by the control panel, or the bottom just below the oven compartment, as combustion air enters through these areas.

NOTICE

Proper ventilation is the owner's responsibility. Any problem due to improper ventilation will not be covered by the warranty.

Be sure to inspect and clean the ventilation system according to the ventilation equipment manufacturer's instructions.

Canopies are set over ranges, ovens, etc., for ventilation purposes. It is recommended that a canopy extend 6" past the appliance and the bottom edge be located 78" above the floor. Filters should be installed at an angle of 45° or more from the horizontal. This position prevents dripping grease and facilitates collecting the run-off grease in a drip pan, unusually installed with a filter.

A strong exhaust fan tends to create a vacuum in the room and may interfere with burner performance or may extinguish pilot flames. Fresh air openings approximately equal to the fan area will relieve such a vacuum.

The exhaust fan should be installed at least 2" above the vent opening at the top of the range.

If the range is connected directly to an outside flue, a CSA design-certified down draft diverter must be installed at the flue outlet of the oven and connected to the flue.

In case of unsatisfactory performance on any appliance, check the appliance with the exhaust fan in the OFF position. Do this only long enough to check equipment performance. Then turn hood back on and let it run to remove any exhaust that may have accumulated during the test.

OPERATION



DANGER

EXPLOSION AND ASPHYXIATION HAZARD

In the event a gas odor is detected, shut down equipment at the main gas shut-off valve and immediately call the emergency phone number of your gas supplier.

Improper ventilation can result in headaches, drowsiness, nausea, and could result in death. Do not obstruct the flow of combustion and ventilation air to and from cooking appliances.



CAUTION

If top-burner pilots go out, the flow of gas to the burners is NOT interrupted (unless the range is equipped with the optional flame-failure safety valves). Consequently, it is the responsibility of the operator to check the ignition of the burners, immediately after burner valve has been turned ON. Should ignition fail after 10 seconds, turn off burners, wait 5 minutes, and then check the pilots and try again.

The controls for the burners and oven(s) are located on the control panel on the front of the range.

If the pilots need to be lit, follow the steps listed in each section below.

LIGHTING AFTER GAS HAS BEEN SHUT OFF

When turning the main gas supply on after the gas supply has been shut off, do the following:

1. Make sure the gas supply valve, located on the front control panel, is in the OFF position.
2. Make sure all of the control knobs are in the OFF position.
3. Turn on the incoming gas supply.
4. Turn the gas supply valve, located on the front control panel, to the ON position.
5. Light the pilots as described below.
6. Light the oven first and then wait six minutes before lighting top burners to purge all air from the range.

OPERATION OF TOP BURNERS

To operate a top burner, turn the corresponding control knob on the front panel to the desired flame level.

Each top burner has its own pilot. If a top-burner pilot needs to be lit, do the following:

1. Turn all the top-burner control knobs to the OFF position.
2. On ranges with standard pilots, use a match or lighter to light all the pilots.
On ranges equipped with Flame Failure, turn one of the top-burner control knobs to the pilot position, push the knob inward, and hold it in place. Depress and hold down the spark switch (the black button between the control knobs). A spark from the igniter to the pilot will be seen and heard. When the pilot lights, release the spark switch, but continue holding the knob in for 30 to 45 seconds. When the knob is released, the pilot should remain lit. Repeat for all the pilots, as needed.

OPERATION OF GAS OVEN

To operate a gas oven, turn the oven-thermostat knob on the front panel to the desired temperature. On convection ovens, the blower is controlled by an ON-OFF switch.

Each oven has its own pilot. If an oven pilot needs to be lit, do the following:

1. Turn the oven thermostat to the OFF position.
2. For convection ovens, turn the fan switch to the OFF position.
3. Open the oven door and remove the oven bottom and fire plate to expose pilot and burner.

4. Open the kick panel below the oven door, turn the knob on the safety valve to the PILOT position, and depress the button on oven safety valve.
5. Light the pilot while continuing to depress the button on the safety valve. Wait 30 seconds, then release the button. The pilot should remain lit.
6. Turn the knob on the safety valve to the ON position.
7. Close the kick panel.
8. Replace the fire plate and oven bottom.

OPERATION OF ELECTRIC OVEN

To operate an electric oven, do the following:

1. Turn the oven switch on the front panel to ON.
2. Turn the thermostat knob on the front panel to the desired temperature.

For electric convection ovens, the fan will run continuously when the oven switch is ON and the oven door is closed.

OPERATION OF INFRARED BROILER INSIDE OVEN

To operate the optional infrared broiler inside of a gas oven, do the following:

1. Turn the oven thermostat OFF.
2. Turn on the oven broiler switch on the front panel to ON.
3. If the broiler fails to light, turn the oven-broiler switch to OFF, open oven door, wait 5 minutes, close oven door, and turn the oven-broiler switch to ON. (The infrared broiler has electronic ignition, so there is no pilot to light.)

Note that the broiler temporarily turns off while the oven door is open.

OPERATION OF NON-THERMOSTATIC GRIDDLES

Ranges can be ordered with a non-thermostatic griddle that is controlled by knobs on the front control panel.

At the end of each use, allow griddle to cool normally. After griddle has cooled, coat griddle surface with a light film of cooking oil to protect surface from moisture.

If a non-thermostatic griddle pilot needs to be lit, do the following:

1. Raise griddle at front so it is approximately 8" (200 mm) high and prop it up with two blocks of wood. On some models, the pilots can instead be lit by inserting a long match or lighter through a hole on the front control panel.
2. Ignite pilot tube located under all burners with port at each side of burners. Pilots are supplied and adjusted by a common valve located below the filter on the manifold.
3. Carefully lower the griddle into position, use the griddle control knob to turn on the griddle, and observe the griddle burners through holes in control panel. When operating, the burners should have a 1/4" to 5/8" (13 to 16 mm) high steady blue flame. Adjust if necessary.

OPERATION OF THERMOSTATIC GRIDDLES

Ranges can be ordered with a thermostatic griddles that is controlled by a knob on the front control panel.

At the end of each use, allow griddle to cool normally. After griddle has cooled, coat griddle surface with a light film of cooking oil to protect surface from moisture.

If a thermostatic griddle pilot needs to be lit, do the following:

1. Raise griddle at front so it is approximately 8" (200 mm) high and prop it up with two blocks of wood. On some models, the pilots can instead be lit by inserting a long match or lighter through a hole on the front control panel.
2. The thermostat sensing bulbs must be fully inserted into their tubular holders, which are welded to the underside of the griddle.
3. One pilot tube is located under all burners with ports at each side of the burners. Pilots are supplied and adjusted by a common valve on the manifold. Light the pilots.
4. Carefully lower the griddle into position taking extreme care that capillary tubes are coiled under manifold in control panel compartment. NEVER leave any part of the capillary tube in the burner compartment.

5. Set the griddle thermostat dials to maximum, one at a time, and observe the griddle burners through holes in control panel. When operating, the burners should have a 1/4" to 5/8" (13 to 16 mm) high steady blue flame. After operating the griddle for ten minutes with the thermostat dial set at maximum, turn the dial to "LOW" and again observe the burners through the holes in the control panel. When the thermostat knob is set "LOW" the burners should have a 1/8" to 1/4" (3 to 6 mm) high steady blue flame. Adjust if necessary.

RAISED-GRIDDLE BROILER

Ranges can be ordered with a raised-griddle broiler that has three separately controlled burners.

At the end of each use, allow griddle to cool normally. After griddle has cooled, coat griddle surface with a light film of cooking oil to protect surface from moisture.

To light the pilots of a raised-griddle broiler, do the following:

1. Remove griddle from unit.
2. Position ceramics on burners with projections pointing downward.
3. Light pilot tube ports (2 at each burner). Adjust pilot flame to be large enough to effect ignition.
4. Place griddle in position on range.
5. Turn control knobs completely on.
6. Burner should have 1/2" to 5/8" steady blue flame. Adjust if necessary.

HOT TOP SECTIONS

The range can be ordered with a hot-top section replacing one or more open-top burner sections. Each hot-top is controlled by a knob on the front control panel.

To light the pilots of a hot-top section, do the following:

1. Raise or remove hot-top plate. Every two burners have one pilot located at the front and in between burners.
2. Light the pilot.
3. Pilot flame should be steady blue, large enough to effect ignition.
4. Turn burner control knob completely on. The sharp blue flame should be approximately 1/4" to 3/8" high.
5. Replace hot top plate.
6. Adjust the burner control knob to the desired setting.

CHARBROILER SECTIONS

Burners have individual control knobs, which can be turned to OFF, HIGH, or LOW. Each burner top-grate can be turned over to provide either wide branding marks or narrower branding marks with channels to carry away drippings (and so reduce flare up). The back-to-front slope of each top-grate is adjusted by positioning the back end of the top-grate on either the lower or the higher grate-support rail. The radiants (just above the burners) can be reversed front-and-back to provide higher heat toward the back than the front, or vice versa.

To start cooking, turn the appropriate control knob to HIGH. Visually check that the burner ignites. **The gas does NOT automatically shut off if the burner does not ignite!** If the burner does not ignite, check and/or light the pilots (see procedure below). When the burner is hot, the burner flame should appear blue and steady (some slight yellowing of the flame tips may occur when using propane gas). When done cooking, turn the appropriate control knob to OFF. (The pilot should remain lit).

A pilot is located near the front of each burner. To light the pilots, do the following:

1. Check that the burner control knob is in the OFF position.
2. Lift up a grate in order to expose the two pilots. They are accessible through a slot near the front end of the radiant plate.
3. Check that each pilot is in the correct position.
4. Turn on the gas supply to the restaurant range (if not already on).
5. Light the pilots with a match or a pilot-lighting device. The pilot flames should be blue and steady.

SHUTDOWN OF ENTIRE RANGE

To completely shut down the range for an extended period (or prior to disconnecting the gas supply), do the following:

1. Turn all burner control knobs to OFF.
2. Turn the oven thermostat knob(s) to OFF.
3. Turn the main gas valve on the control panel to OFF.

TROUBLESHOOTING BY OPERATOR

The following table lists the possible causes and solutions of problems that may occur during operation.

Problem	Possible Causes and Solutions
A top burner will not light.	<ul style="list-style-type: none"> - Check pilot position. - Check and light the burner's pilot. - Check gas supply to range.
Oven will not heat up.	<ul style="list-style-type: none"> - Check and light the oven pilot. - Check gas supply to range.
Blower of convection oven is not running.	<ul style="list-style-type: none"> - Check that the oven's blower control switch is in ON position. - Check electricity supply to range.
Pilot(s) will not remain lit.	<ul style="list-style-type: none"> - Check gas supply to range. - Check pilot adjustment.

If other appliances connected to the same source of gas or electricity are also not operating correctly, the problem is likely not within the range.

If the problem only occurs for the range, and if the above solutions do not solve the problem, call for repair service.

TROUBLESHOOTING CONVECTION-OVEN COOKING PROBLEMS

If...	then...
Cakes are dark on the sides and not done in the center...	lower oven temperature.
Cake edges are too brown...	reduce number of pans or lower oven temperature.
Cakes have light outer color...	raise temperature.
Cake settles slightly in the center...	bake longer or raise oven temperature slightly. Do not open doors too often for long periods.
Pies have uneven color...	reduce number of pies per rack.
Meats are browned and not done in center...	lower oven temperature and roast longer.
Meats are well done and not browned...	raise temperature. Limit amount of moisture.
Cakes ripple...	overloading pans or batter is too thin.
There is excessive meat shrinkage...	lower oven temperature.
Cakes are too coarse...	lower oven temperature.

WARNING

THE USE OF ALUMINUM FOIL CAN CAUSE HEAT DISTRIBUTION PROBLEMS IN OVENS. EXTREME CARE MUST BE USED WHEN PLACING ALUMINUM FOIL IN THE OVEN TO ENSURE THAT IT DOES NOT BLOCK OR CHANGE THE AIR FLOW. THE USE OF ALUMINUM FOIL MAY VOID THE PRODUCT WARRANTY IF ITS USE IS ASCERTAINED TO BE A PROBLEM.

COOKING TIPS FOR CONVECTION OVENS

As a guide, set oven temperatures 25 to 50 degrees lower than called for in recipes using conventional (non-convection) ovens.

FROZEN ENTREE PRODUCTS: Punch holes in lid before heating. Tent lid if product has a tendency to stick, i.e., lasagna or macaroni and cheese. Use manufacturer's convection oven directions for time and temperature or reduce conventional oven temperature 50 degrees for a 6 pan load. Some products may cook in 10 to 15 minutes less time than recommended for convection ovens if prepared from frozen in a 6 pan load.

Time and temperatures will vary depending upon load, mix, size of portion, and other factors. Use the following chart to develop your own cooking techniques:

Product	Timing (minutes)	Temperature Setting	Number of Racks Used	Count per Pan/Rack
Hamburger buns, 3 oz. - 4"	18	375°	2	24
Yeast rolls - 1 oz. Use temperature and time recommended by manufacturer for convection ovens for a 3 pan load.	10	400°	2	48
Fruit pies, 46 oz. frozen Use temperature and time from manufacturer's directions for convection ovens for a 12 pie load placed on 3 bun pans.	50	375°	2	4
Egg custard pies, 44 oz. frozen	60	325°	2	4
Dutch apple pies, 46 oz. frozen	50	350°	2	4
Baked potatoes, 8 oz. Wash and wrap in potato foil. Place 30 potatoes on 18 x 24 bun pan — 3 pans per load. Bake in 400°F oven for 1 hour.	60	400°	2	30 (wrapped)
Pre-blanch potatoes, frozen Spread on ungreased bun pans, 3 pans per load. Bake at 400°F, stirring once, for 15 to 18 minutes.	16	400°	2	5 lb.
Fish portions, pre-cooked, breaded, 3 oz. Use manufacturer's recommended temperature and time for convection oven for a 3 pan load.	16	400°	2	32
Macaroni & cheese, 6 lbs. - 40° temp.	45	400°	2	2-6 lbs.
Lasagna w/meat sauce, 6 lb. - 40° temp.	60	350°	2	2 - 6 lbs.
Lasagna w/meat sauce, 6 lb. - frozen	75	350°	2	2-6 lbs.
Salisbury steak w/gravy, 6 lb. - 40° temp.	45	400°	2	2-6 lbs.
Top round of beef No. 168				
14 lb. - rare	140° internal 14 min./lb.	250°	1	1 - 2
14 lb. - medium	150° internal 14 min./lb.	250°	1	1 - 2
14 lb. - well done	160° internal 14 min./lb.	250°	1	1 - 2

CLEANING & MAINTENANCE

WARNING

Shut off the range and allow time for it to cool before cleaning or performing maintenance.

Southbend appliances are sturdily constructed of the best materials and are designed to provide durable service when treated with ordinary care. To expect the best performance, your equipment must be maintained in good condition and cleaned daily. Naturally, the periods for this care and cleaning depend on the amount and degree of usage.

Following daily and periodic maintenance procedures will enhance long life for your equipment. Climatic conditions (such as salt air) may require more thorough and frequent cleaning or the life of the equipment could be adversely affected.

Keep exposed, cleanable areas clean at all times.

DAILY CLEANING

1. Turn all controls to OFF and allow time for the range to cool.
2. Remove, empty, and clean drip trays.
3. Wipe clean all cooking surfaces.

PERIODIC CLEANING AND MAINTENANCE

At least monthly, clean around burner air mixers and orifices if lint has accumulated and visually check proper pilot operation.

At least twice a year, examine and clean the range hood and venting system.

CLEANING OVEN INTERIOR

WARNING

FOR YOUR SAFETY, BEFORE CLEANING A CONVECTION OVEN DISCONNECT THE POWER SUPPLY. WHEN CLEANING THE BLOWER WHEEL, BE SURE THAT THE POWER SWITCH IN THE "OFF" POSITION.

Allow oven to cool. Remove porcelain enameled oven bottom. Clean by rubbing with strong detergent and Brillo pad or similar scrubber. "Spill-overs" should be cleaned from the bottom as soon as possible to prevent carbonizing and a "burnt-on" condition. For stubborn accumulations, commercial oven cleaners are recommended.

The porcelain oven lining can be cleaned in a similar manner.

Avoid using excessive amounts of water, as this may drip into burner compartment and deteriorate the metal in that area.

BAKED-ENAMEL SURFACES

Wash interior baked-enamel surfaces with a hot, mild detergent or soap solution to clean off all grease deposits. Dry thoroughly with a dry cloth.

STAINLESS-STEEL SURFACES

To remove normal dirt, grease and product residue from stainless steel surfaces that operate at LOW temperature, use ordinary soap and water (with or without detergent) applied with a sponge or cloth. Dry thoroughly with a clean cloth.

To remove BAKED-ON grease and food splatter, or condensed vapors; apply cleanser to a damp cloth or sponge and rub cleanser on the metal in the direction of the polishing lines on the metal. Rubbing cleanser, as gently as possible, in the direction of the polished lines will not mar the finish of the stainless steel. NEVER RUB WITH A CIRCULAR MOTION. Soil and burnt deposits which do not respond to the above procedure can usually be removed by rubbing

the surface with SCOTCH-BRITE scouring pads or STAINLESS scouring pads. DO NOT USE ORDINARY STEEL WOOL as any particles left on the surface will rust and further spoil the appearance of the finish. NEVER USE A WIRE BRUSH, STEEL SCOURING PADS (EXCEPT STAINLESS), SCRAPER, FILE OR OTHER STEEL TOOLS. Surfaces which are marred collect dirt more rapidly and become more difficult to clean. Marring also increases the possibility of corrosive attack. Refinishing may then be required.

“Heat tint” is darkened areas that sometimes appear on stainless steel surfaces where the area has been subjected to excessive heat. These darkened areas are caused by thickening of the protective surface of the stainless steel and are not harmful. Heat tint can normally be removed by the foregoing, but tint which does not respond to this procedure calls for a vigorous scouring in the direction of the polish lines using SCOTCH-BRITE scouring pads or a STAINLESS scouring pad in combination with a powered cleanser. Heat tint may be lessened by reducing heat to equipment during slack periods.

BRIGHT-ANNEALED STAINLESS-STEEL SURFACES

To remove normal dirt, grease and product residue from stainless steel surfaces that operate at LOW temperature, use ordinary soap and water (with or without detergent) applied with a sponge or cloth. Dry thoroughly with a clean cloth. Never use any abrasive cleaner, pad, wire brush, scraper, or file to remove material from the bright-annealed surfaces.

CARE OF GRIDDLES

New griddles should be carefully tempered and cared for in order to avoid possible damage. To break in a new griddle, first wipe it clean. Next, light all the griddle burners and turn them to low for one hour. Then gradually bring each griddle up to frying temperature. Next, spread three or four ounces of beef suet, or as a substitute, baking soda, to season it. Never allow water on a hot griddle and never wash it with soap and water.

Use a Norton Alundum Griddle Brick to clean the griddle. Always remember to heat griddle slowly because quick heat may cause costly damage. Griddle plates cannot be guaranteed against damage due to carelessness. Never place utensils on griddle. Do not overheat griddle above 550°F (288°C), as this will cause warpage or breakage.

Do not use any type of steel wool. Small particles may be left on the surface and get into food products. Do not clean spatula by hitting the edge on the griddle plate. Such action will only cut and pit the griddle plate, leaving it rough and hard to clean.

Do not waste gas or abuse equipment by leaving control knobs at “Full On” position or thermostat at a high temperature if not required. During idle periods, set control knobs at “Low” position or thermostats to low temperature settings to keep griddle warm. Reset control knobs or thermostats, as required, for periods of heavy load. Turn control knobs or thermostats to OFF at end of daily operation.

HOT TOPS

Allow range to cool. If water is used on tops while still hot, they may crack. Avoid this practice. Remove tops from range and clean surfaces with hot water and detergent. A wire brush may be used on the underside of the hot top plate. It is recommended not to clean tops while still on range, even if cooled, as excessive water will drip into the burner box and deteriorate the metal.

Do not waste gas and abuse equipment by leaving all burners “Full On,” if not required. During idling periods, adjust burner control knobs to keep top warm. Re-adjust burner control knobs as required for periods of heavy loads.

TOP BURNERS

Little attention is needed, but if spillage should occur, it may be necessary to clean around pilot areas, air mixer and under burners. Use a wire brush if necessary.

Periodically, burners (particularly open top type) should be removed and cleaned. Allow interior to drain. Dry thoroughly before replacing.

Burner grates can be lifted out for cleaning. Clean them with a solution of hot water and strong soap or detergent.

The flash tubes must be clean and properly aligned with the pilot housing to insure good top burner ignition. Pilots should have a 1/2" to 5/8" blue flame. Avoid carbon producing tip or unstable blowing or lifting of flame.

INSTALLATION

NOTICE

These installation procedures must be followed by qualified personnel or warranty will be void.

Local codes regarding installation vary greatly from one area to another. The National Fire Protection Association, Inc., states in its NFPA 96 latest edition that local codes are the “authority having jurisdiction” when it comes to installation requirements for equipment. Therefore, installations should comply with all local codes.

The installation must conform with local codes, or in the absence of local codes, with the *National Fuel Gas Code, ANSI Z223.1, Natural Gas Installation Code, CAN/CGA-B149.1*, or the *Propane Installation Code CAN/CGA-B149.2*, as applicable, including:

1. The appliance and its individual shutoff valve must be disconnected from the gas supply piping system during any pressure testing of that system at test pressures in excess of 1/2 psi (3.45 kPa).
2. The appliance must be isolated from the gas supply piping system by closing its individual manual shutoff valve during any pressure testing of the gas supply piping system at test pressures equal to or less than 1/2 psi (3.45 kPa).

NOTICE

EXHAUST FANS AND CANOPIES: It is recommended that the range be installed under a ventilation hood. Consult local codes for proper installation of hoods. Proper ventilation is the owner’s responsibility. Any problem due to improper ventilation will not be covered by warranty.

NOTICE

In the Commonwealth of Massachusetts all gas appliances vented by either mechanical systems or ventilation hoods shall comply with 248 CMR interlocking requirements.

STEP 1: UNPACKING

IMMEDIATELY INSPECT FOR SHIPPING DAMAGE

All containers should be examined for damage before and during unloading. The freight carrier has assumed responsibility for its safe transit and delivery. If damaged equipment is received, either apparent or concealed, a claim must be made with the delivering carrier.

Apparent damage or loss must be noted on the freight bill at the time of delivery. The freight bill must then be signed by the carrier representative (Driver). If the bill is not signed, the carrier may refuse the claim. The carrier can supply the necessary forms.

A request for inspection must be made to the carrier within 15 days if there is concealed damage or loss that is not apparent until after the equipment is uncrated. The carrier should arrange an inspection. Be certain to hold all contents plus all packing material.

Do the following:

1. Cut the banding straps and remove the corrugated cardboard surrounding the range. If legs were shipped in the same container, set them aside for installation in later steps of this procedure. Do not remove any tags or labels attached to the range until the range is installed and working properly.
2. Lift the flue riser and shelf (if applicable) off the range and set it aside for installation later in this procedure.
3. Unbolt the shipping hold-down brackets from the skid, then remove the brackets from the range. Replace the bolts back into the threaded holes in the range.
4. If the range is to be installed on legs, go to Step 2a.
If the range is to be installed on casters, go to Step 2b.

STEP 2A: ATTACH LEGS

A set of four legs is packed with ranges ordered with legs. (For ranges ordered with casters, go to Step 2b.)

A threaded leg pad is fastened to the base frame at each corner. Each leg has a corresponding mating thread. The legs can be adjusted to overcome a slightly uneven floor.

1. Raise range sufficiently to allow legs to be attached. For safety, “shore up” and support the range with an adequate blocking arrangement strong enough to support the load.
2. Screw the legs into the holes in the centers of the leg pads. The legs should be fully screwed into the leg pads.
3. Lower range gently onto a level surface. Never drop or allow the range to fall.
4. Use a level to make sure that the range surface is level. The foot of each leg can be screwed in or out to lower or raise each corner of the range.
5. Go on to Installation Step 3.

Figure 3

Installation of Legs

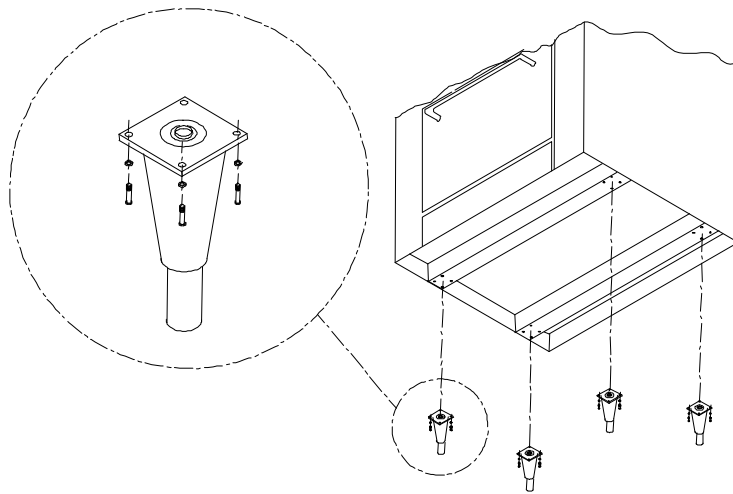

STEP 2B: ATTACH CASTERS AND RESTRAINT

NOTICE

For an appliance equipped with casters, (1) the installation shall be made with a connector that complies with the *Standard for Connectors for Movable Gas Appliances, ANSI Z21.69* or *Connectors for Moveable Gas Appliances, CAN/CGA-6.16*, and a quick-disconnect device that complies with the *Standard for Quick-Disconnect Devices for Use With Gas Fuel, ANSI Z21.41*, or *Quick Disconnect Devices for Use with Gas Fuel, CAN1-6.9*, (2) adequate means must be provided to limit the movement of the appliance without depending on the connector and the quick-disconnect device or its associated piping to limit the appliance movement, and (3) the restraining means should be attached to a frame member on the back of the unit.

A set of four casters is packed with ranges ordered with casters (instead of legs).

A threaded leg pad is fastened to the base frame at each corner. Each caster has a corresponding mating thread. The casters can be adjusted to overcome a slightly uneven floor. Casters are provided with a fitting for proper lubrication when required.

1. Raise range sufficiently to allow the casters to be attached. For safety, “shore up” and support the range with an adequate blocking arrangement strong enough to support the load.
2. Screw the casters into the holes in the centers of the leg pads. Install the casters that have a locking brake under the front of the range.
3. Lower range gently onto a level surface. Never drop or allow the range to fall.
4. Use a level to make sure that the range surface is level. The casters can be screwed in or out slightly to lower or raise each corner of the range.

Figure 4

Installation of Casters

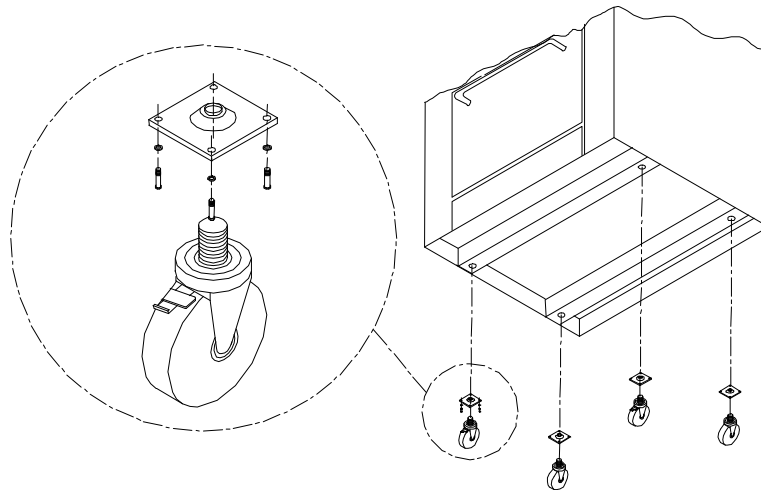

5. Secure the restraining-device bracket (item “B” in the following illustration) to a wall stud located as close as possible to the appliance connector inlet and outlet connections. Use four #12 screws (items “C”) and plastic anchors (items “A”) if necessary.
6. Install eye-bolt (item “F”) to a frame member on the rear of the equipment. After checking carefully behind the frame member for adequate clearance, drill a 1/4” (6 mm) hole through the frame member.
7. Thread hex nut (item “G”) and slide the washer (item “H”) onto the eye-bolt. Insert the eye-bolt through the 1/4” (6 mm) drilled hole and secure with a washer (item “H”) and nylon lock nut (item “I”).
8. Using the spring-loaded snap hooks, attach the restraining device to the bracket and the eye-bolt.
9. Using the cable clamp (item “D”), adjust the restraining device extended length to prevent over-bending or kinking of the appliance connector.

Figure 5

Installation of Restraint

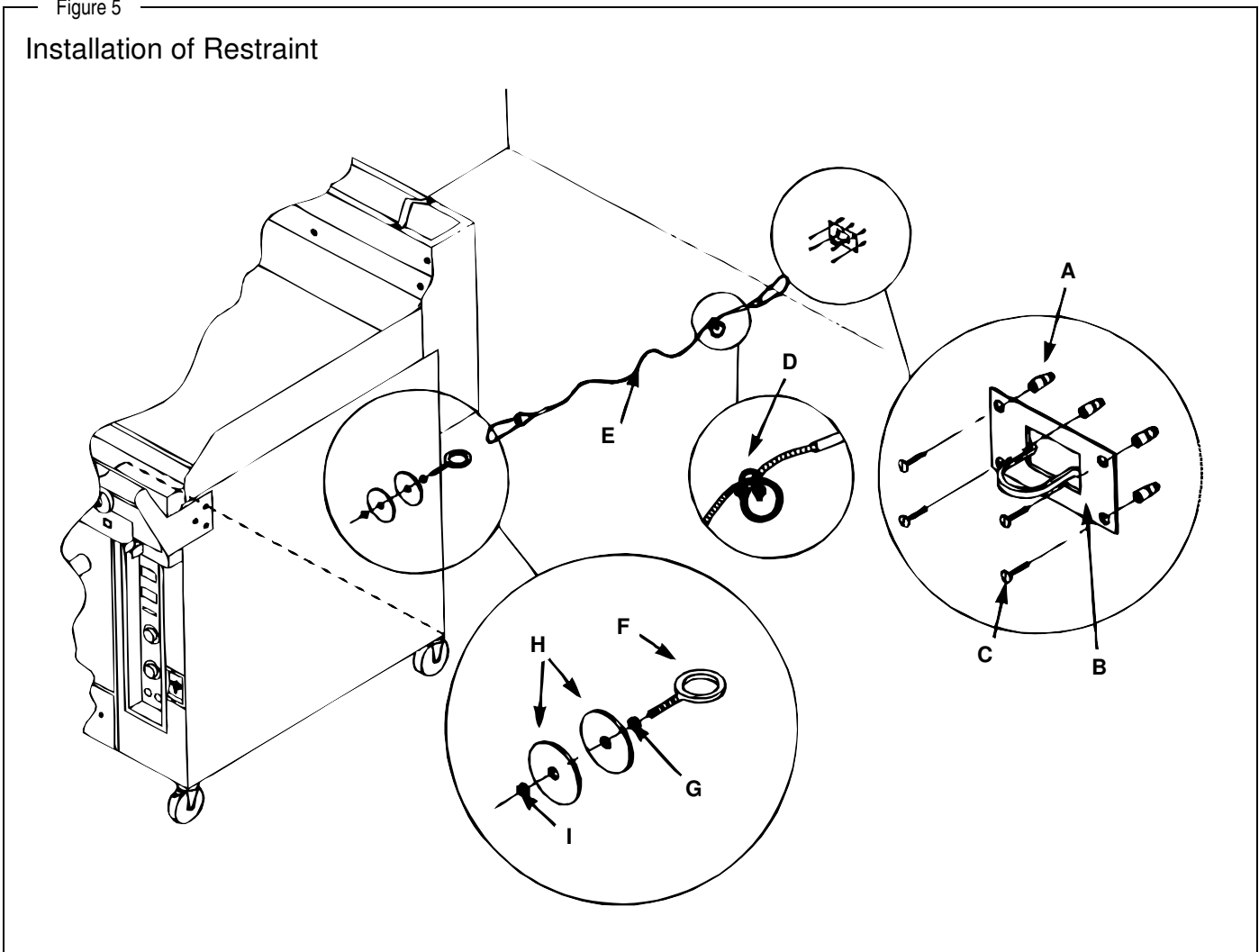

Be sure all controls are turned off prior to disconnecting. After reconnecting, be sure all controls are turned off and all pilots are lit.

NOTICE

Adequate means must be provided to limit the movement of the appliance without depending on the connector and the quick-disconnect device or its associated piping to limit the appliance movement.

The restraining means should be attached to a frame member on the back of the range.

STEP 3: ATTACH FLUE RISER AND SHELF ASSEMBLY

Place the flue riser assembly on the range as shown on the appropriate diagram below.

1. Slide the flue riser assembly over the bayonets until it bottoms out, as shown below.
2. Secure ends of flue riser assembly with two (2) 1/4-20 x 3/4 hex head bolts, flat washers and lockwashers.
3. Attach the shelf assembly (if ordered) to the flue riser assembly with 1/4-20 x 3/4 hex head bolts, flat washers and lockwashers.

Figure 6

Installation of Flue Riser and Shelf Assembly

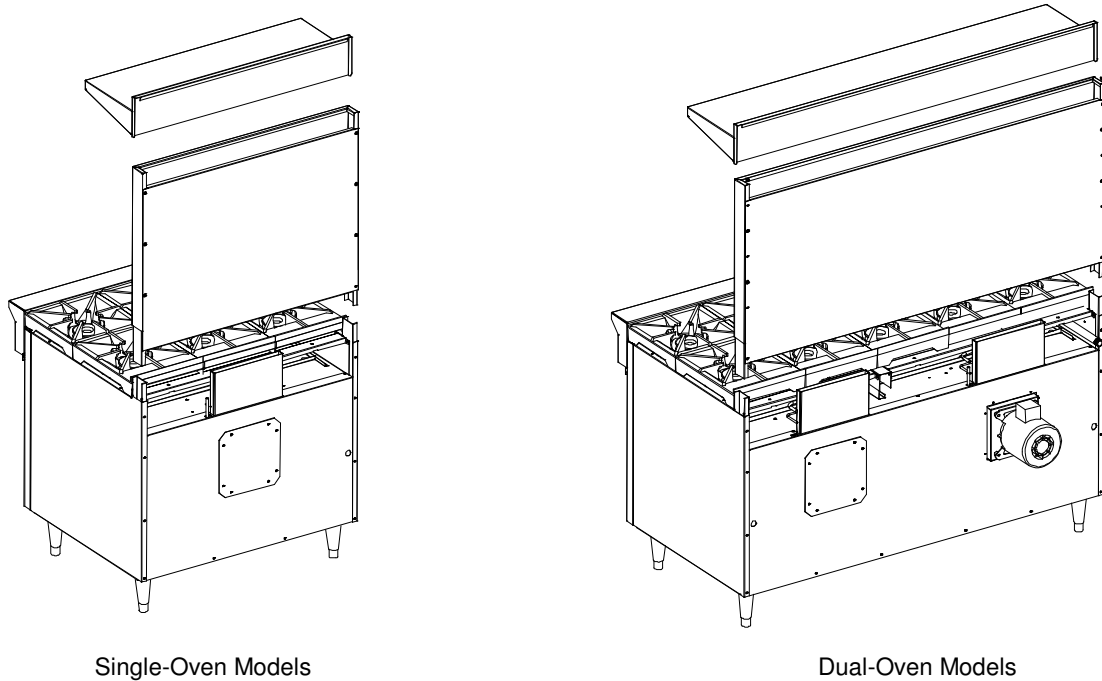

STEP 4: ELECTRICAL CONNECTION

Wiring diagrams are located on the rear of the range. Be sure that the input voltage and phase match the requirements shown on the serial plate (see Figure 1 on page 3).

Ranges are factory-equipped either with a power cord or with one or two two-pole terminal blocks (one for each oven), located behind cover plate(s) located on the rear of the range. To connect the supply wires, remove the appropriate cover plate. Route the supply wires and the grounding wire through the strain relief fitting to the terminal block. Insert the supply wires, one each, into the two poles of the terminal block and tighten the screws. Insert the ground wire into the grounding lug and tighten the screw. Re-attach the cover plate.

Three phase ranges are wired as above, using only two supply wires. The third wire is not used and must be properly terminated.

All ranges are shipped wired as specified by factory order. Conversion between single-phase and three-phase can be accomplished by referring to phase loading and line amperes chart on wiring diagram for wire size and ampere requirements.

STEP 5: GAS CONNECTION

If this equipment is being installed at over 610 meters altitude and that information was not specified when ordered, contact the appropriate authorized Southbend Service Representative or the Southbend Service Department. Failure to install with proper orifice sizing will result in poor performance and may void the warranty.

The serial plate is located on the interior side of the kick panel below the oven. It indicates the type of gas the range is equipped to burn. All Southbend equipment is adjusted at the factory. Check type of gas on serial plate.

These models are design-certified for operation on natural or propane gases. For natural gas, the regulator is set to deliver gas at 0.99 kPa (4" W.C.) pressure to the manifold. For propane gas, it is set to 2.48 kPa (10" W.C.).

This appliance should be connected ONLY to the type of gas for which it is equipped.

An adequate gas supply is imperative. Undersized or low pressure lines will restrict the volume of gas required for satisfactory performance. A 1/8" pressure tap is located on the manifold to measure the manifold pressure.

The gas supply line to the range should be no smaller than the inside diameter of the pipes to which it is connected.

Purge the supply line to clean out dust, dirt, or other foreign matter before connecting the line to the range.

CAUTION

ALL PIPE JOINTS AND CONNECTIONS MUST BE TESTED THOROUGHLY FOR GAS LEAKS. USE ONLY SOAPY WATER FOR TESTING ON ALL GASES. NEVER USE AN OPEN FLAME TO CHECK FOR GAS LEAKS. ALL CONNECTIONS MUST BE CHECKED FOR LEAKS AFTER THE RANGE HAS BEEN PUT INTO OPERATION. TEST PRESSURE SHOULD NOT EXCEED 14" W.C. (3.47 kPa).

STEP 6: CHECK THE INSTALLATION

Check the installation of the range, as follows:

1. Check that all screws and bolts are tightened.
2. Check that the electrical and gas connections have been made correctly.
3. With the range in the position that it will be operated, check that the range is level. If not, adjust the legs or casters.
4. Check that the appropriate minimum clearances are satisfied (see page 4).
5. Check that the oven door(s) open and close properly.
6. Check that there is sufficient clearance in front of the range to open the oven door.
7. Wipe clean all surfaces.

STEP 7: CHECK OPERATION

Check the operation of the range, as follows:

1. Turn on the gas supply and, for convection-oven models, the electric power supply.
2. Light the burner pilots and oven pilot(s), starting with the top burner farthest from the gas input in order to purge the system of air. Check for proper pilot-flame height and adjust pilots, if necessary.
3. Turn on the oven and all burners at the same time. Check for correct burner operation and adjust the air shutters, if necessary.
4. On convection-oven models, turn on the blower(s) and check for proper operation.
5. Turn off the burners and oven.

STEP 8: SHUT-DOWN AND WIPE-CLEAN RANGE

Complete the installation by leaving the range ready for customer use:

1. Allow the range to cool.
2. Wipe clean all surfaces.
3. Unless the range is to be placed in service immediately, turn off the gas supply and (for convection-oven models, the electricity supply).
4. Make sure that a copy of this manual will be available to the people who will operate and maintain the range.

SERVICE

WARNING

ADJUSTMENTS AND SERVICE WORK MAY BE PERFORMED ONLY BY A QUALIFIED TECHNICIAN WHO IS EXPERIENCED IN, AND KNOWLEDGEABLE WITH, THE OPERATION OF COMMERCIAL COOKING EQUIPMENT. TO ASSURE YOUR CONFIDENCE, CONTACT YOUR AUTHORIZED SERVICE AGENCY FOR RELIABLE SERVICE, DEPENDABLE ADVICE OR OTHER ASSISTANCE, AND FOR GENUINE FACTORY PARTS.

NOTICE

INSTALLATION OF OTHER THAN GENUINE SOUTHBEND PARTS WILL VOID THE WARRANTY ON THIS EQUIPMENT.

The serial plate are located on the right side of the range (see Figure 1 on page 3).

Replacement parts (including parts not listed in this manual) may be ordered either through a Southbend Authorized Parts Distributor or a Southbend Authorized Service Agency.

When ordering parts, please supply the Model Number, Serial Number, Part Number, and Part Description.

In case of problems in operation at initial installation, check type of gas and manifold pressure and compare with information listed on the serial plate.

This section contains troubleshooting flowcharts, procedures, and electric schematics to assist a qualified service technician in the servicing of a Southbend Ultimate Restaurant Range.

TROUBLESHOOTING FLOWCHARTS, PROCEDURES, AND WIRING DIAGRAMS

Find the symptom below that corresponds to the malfunction, then turn to the corresponding page. Follow the flowchart on that page until the problem is solved.

Troubleshooting Flowchart, Procedure, or Wiring Diagram	Page
Troubleshooting Open-Top Burners	22
Troubleshooting Base Oven	23
Troubleshooting Convection-Oven Blower	24
Adjustment of Gas Pressure Regulator	26
Adjustment of Open-Top Pilots	27
Adjustment of Open-Top Burners	27
Adjustment of Oven Standing Pilot	27
Adjustment of Oven Burner	27
Adjustment of Charbroiler, Standard-Griddle, and Uniform Hot-Top Burners and Pilots	27
Calibration of Oven Thermostat	28
Adjustment of Thermostatic Griddle Bypass Flame Level	28
Calibration of Thermostatic Griddle Thermostat	28
Conversion from One Type of Gas to Another	29
Wiring Diagram for Gas Oven	30
Wiring Diagram for Infrared Broiler in Gas Oven Cavity	31
Wiring Diagram for Electric Standard Oven	32
Wiring Diagram for Electric Convection Oven	33

TROUBLESHOOTING OPEN-TOP BURNERS

Each open-top burner should have a steady blue flame on each port of the burner. Propane burners may have a small amount of yellow tipping, and may make a slight popping noise when turned off.

If the flame is rising up off of the ports, adjust the burner shutter so it is more closed. If the flame is long and yellow adjust the burner shutter so it is more open.

Consult the following table and the flowchart on this page.

Problem	Look for -
No burners or pilots in the range will turn on.	– Main gas supply to range is OFF.
Spark electrode does not spark (to light pilot).	– Battery (inside corresponding spark module on rear of range) needs replacement.
All burners produce excessive carbon deposits.	– Incorrect gas type supplied to range. – Incorrect supply pressure.
Only some burners in a range produce excessive carbon deposits.	– Incorrect orifices or orifice alignment. – Primary air not adjusted properly.
Only some pilots produce excessive carbon deposits.	– Pilot gas not adjusted properly. – Incorrect pilot orifice.
Top burner will not come on, but oven will come on.	– Control knob for top burner is in OFF position. – Pilot out.
Open-top burner pilot will not stay ignited.	– Pilot gas not adjusted properly. – Clogged orifice. – Draft condition. – Improper ventilation system. – Air in gas line. – Thermocouple bad.

Figure 7

Troubleshooting Open-Top Burners

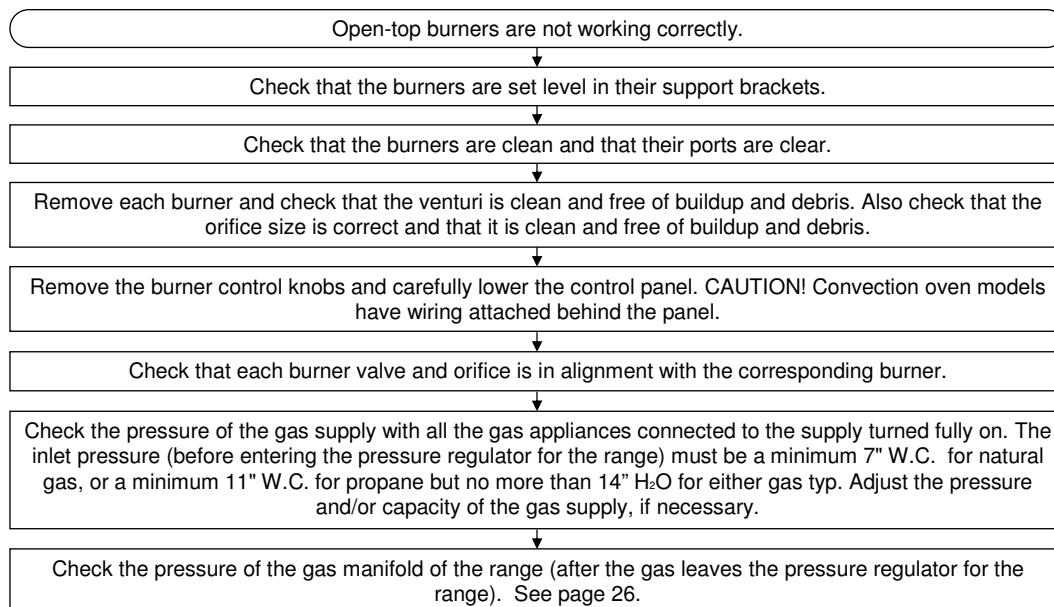

TROUBLESHOOTING BASE OVEN

CAUTION

Proper and efficient operation of oven is dependent on correct installation and function of components. Always verify that components are in place and functioning as intended.

Consult the following table and the flowchart that begins on the following page.

Problem	Look for -
Oven will not come on.	– Oven pilot is out.
Oven pilot will not stay ignited	<ul style="list-style-type: none"> – Pilot gas not adjusted properly. – Bad thermopile. – Bad thermopile connections at safety valve. – Bad safety valve. – Clogged orifice. – Dirty pilot – Draft condition. – Improper ventilation system. – Air in gas line.

Figure 8

Troubleshooting Oven Pilot

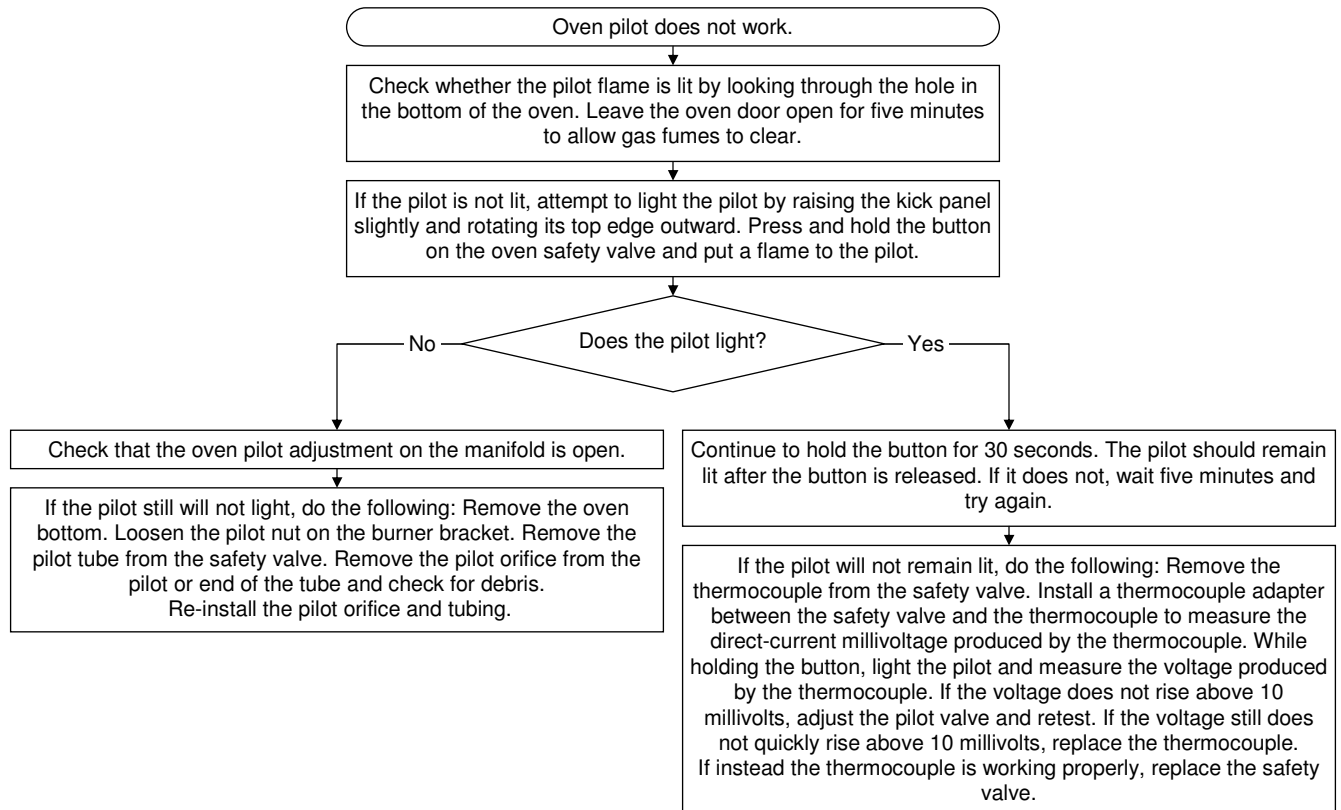

TROUBLESHOOTING CONVECTION-OVEN BLOWER

⚠ WARNING

Before attempting to service or replace any electrical component, make sure power source has been disconnected.

⚠ CAUTION

When changing motor or servicing range, always verify that blower wheel rotation is clockwise when looking into the oven cavity.

If the blower does not run at all, consult the flowchart that begins on the next page. If the blower runs intermittently, consult the flowchart on this page.

The appropriate wiring diagram for the oven can be found on the rear of the oven (as well as at the end of this section of this manual).

Figure 9

Convection-Oven Blower Runs Intermittently

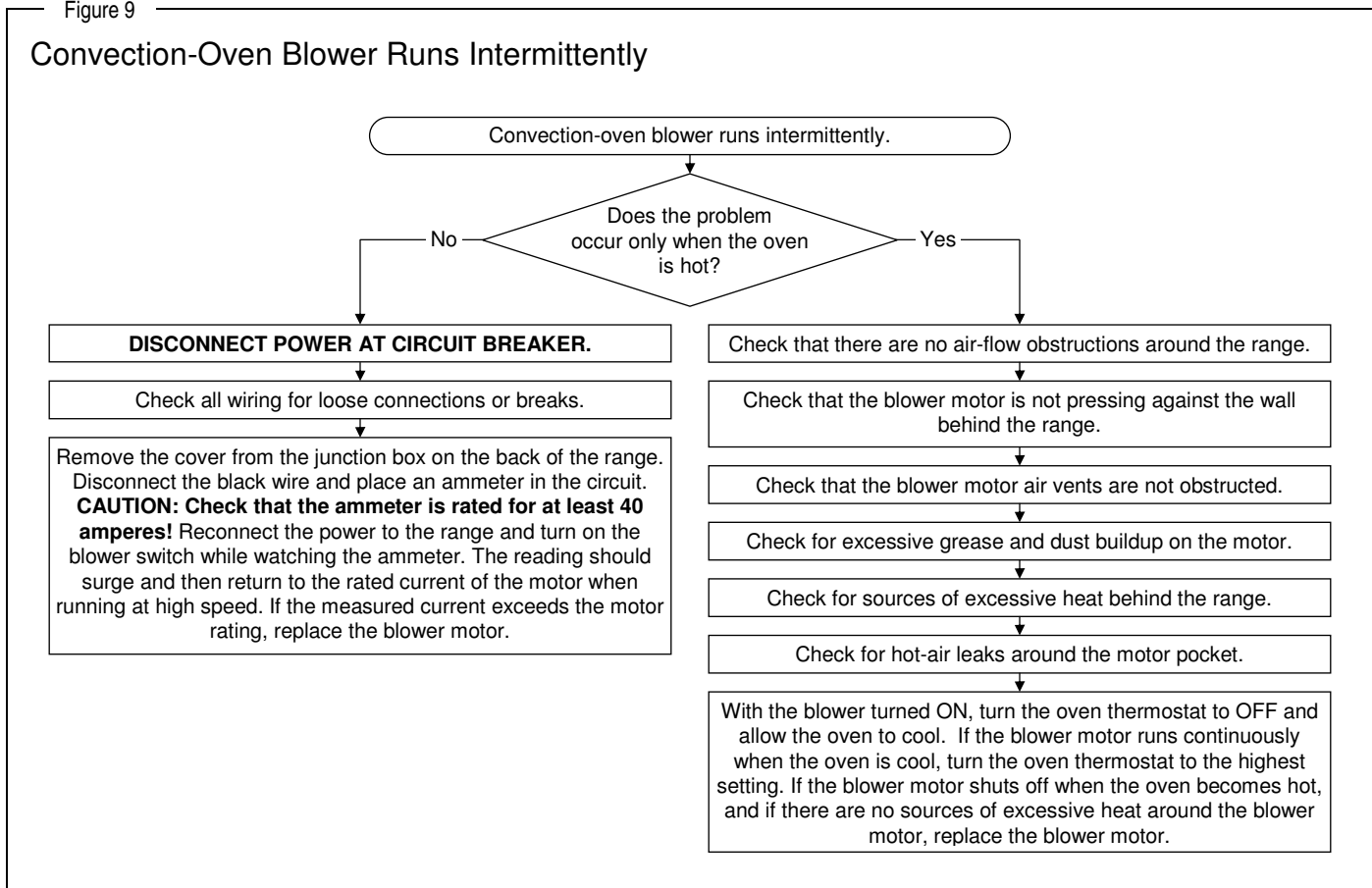

Figure 10

Convection-Oven Blower Does Not Run

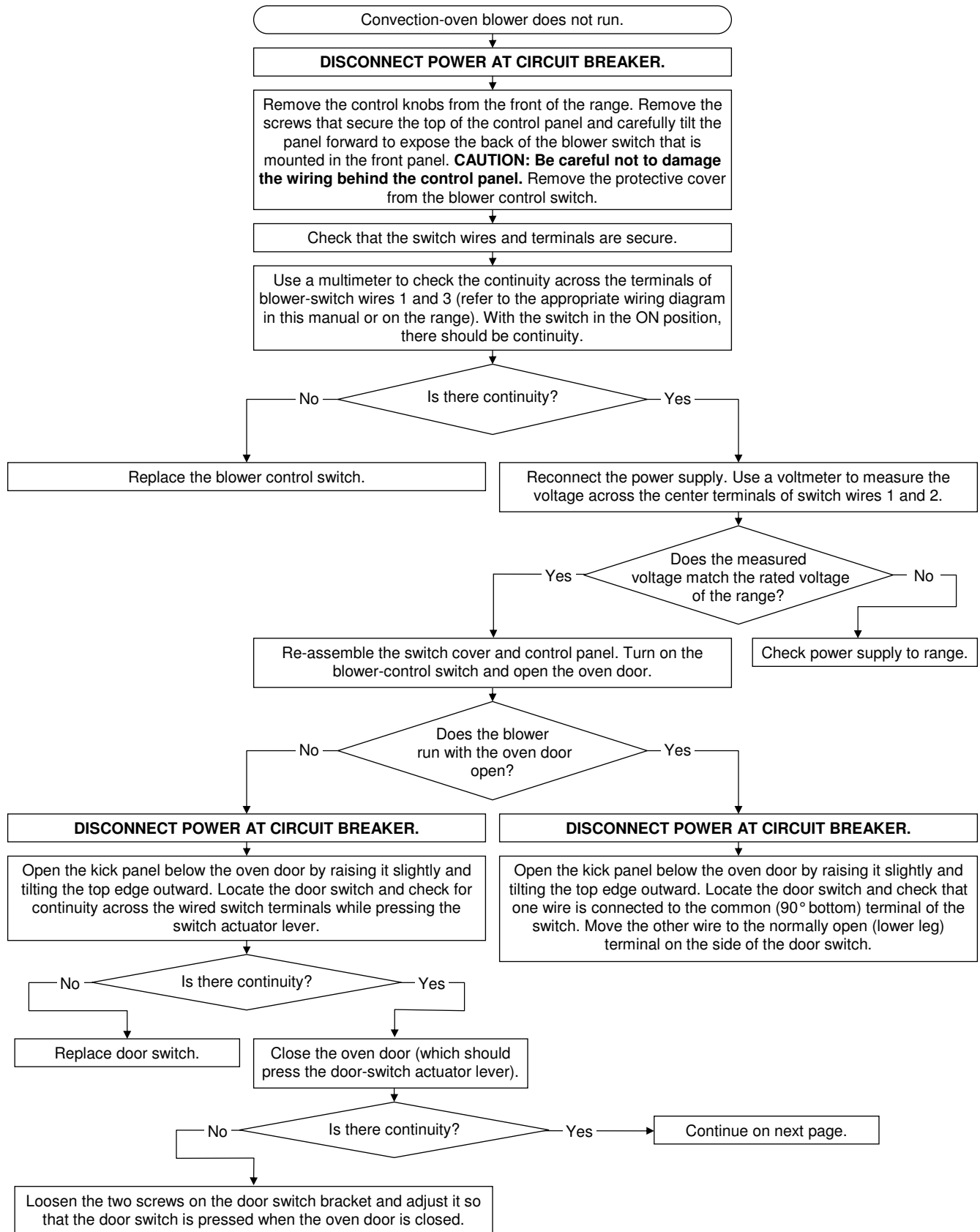
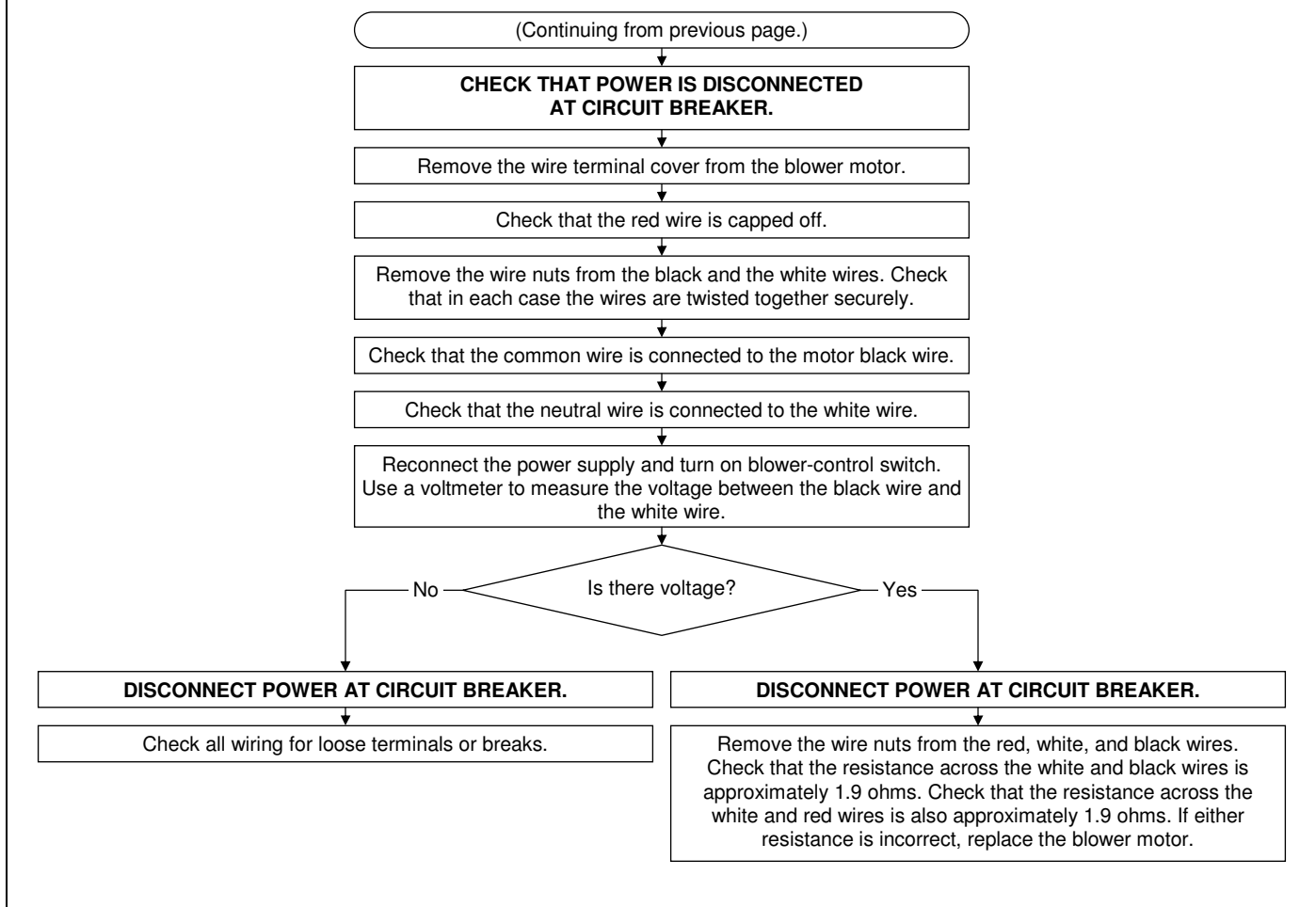

Figure 11

Convection-Oven Blower Does Not Run, Continued



ADJUSTMENT OF GAS PRESSURE REGULATOR

The pressure regulator is factory set at 4" W.C. (0.99 kPa) for natural gas and 10" W.C. (2.48 kPa) for propane gas. To check the manifold pressure:

1. Turn all thermostats and burner control knobs to OFF position.
2. Turn main gas valve to entire range off.
3. Remove control panel and locate the small plug in the manifold.
4. Remove plug and install a fitting appropriate to connect a manometer.
5. Turn on main gas to range and light pilots.
6. Turn all burners and ovens to full ON position and read manometer.
7. If manometer does not read 4" W.C. (0.99 kPa) for natural gas, or 10" W.C. (2.48 kPa) for propane gas, adjust regulator (if gas pressure is correct go to Step 10).
8. Remove cap from top of regulator.
9. With a screwdriver rotate regulator adjustment screw clockwise to increase, or counterclockwise to decrease, pressure until manometer shows correct reading.
10. Repeat steps 1 and 2.
11. Remove manometer fitting and replace plug in manifold.
12. Turn on main gas to range and light pilots.
13. Replace control panel.

ADJUSTMENT OF OPEN-TOP PILOTS

The open-top pilots are the non-aerated (yellow-tipped flame) type. One is located beside each open-top burner.

Pilot outage is often caused by an unstable flame due to over-adjustment to the point where the flame is leaving its port, or "blowing off." Often, in an effort to improve ignition, the pilots are increased too much and result in this unstable condition.

The pilots are adjusted by inserting the blade of a screwdriver into the slot on the small valve, located on the manifold. The maximum flame size is approximately 3/4" (19 mm) with a slight yellow tip. The first indication of over-adjustment is evident when the yellow tip begins to stream into black streaks and generate carbon. Continued over-adjustment leads to the unstable lifting and blowing condition.

ADJUSTMENT OF OPEN-TOP BURNERS

All open-top burners are primarily adjusted by means of an air shutter on the mixer face.

To adjust a burner, loosen the screw that holds the air shutter in position and rotate the mixer cap until a clear, stable blue flame is obtained. The flame should not be yellow tipped nor should it blow off the burner ports.

All orifice sizes and burner rate are properly set at the factory and should not be altered.

Over-rated burners cause poor burner and pilot performance, resulting in less heat, and wasted gas.

ADJUSTMENT OF GAS OVEN STANDING PILOT

The standing oven pilot flame can be adjusted by turning the adjusting screw on the pilot line valve with a screwdriver. The pilot line valve is located behind the kick panel below the oven door. Remove the kick panel to gain access. The pilot flame is properly adjusted when it is just large enough to maintain a glowing red color of the thermopile capillary bulb.

ADJUSTMENT OF GAS OVEN BURNER

The oven burner orifice is of the fixed type, sized for the specified gas supply. The burner flame characteristics are controlled by varying the primary air mixer cap. There should be a clear blue flame with a distinct inner cone at each port. Excessive primary air can result in "blowing" or the flames leaving the ports. Lack of primary air causes soft or yellow tipped flame.

ADJUSTMENT OF CHARBROILER, STANDARD-GRIDDLE, AND UNIFORM HOT-TOP BURNERS AND PILOTS

The burner valves are not adjustable. The burner orifice is of the fixed type, sized for the type of gas and the operating altitude. To adjust the burner air-gas mixture, loosen the screw that secures the air shutter on the mixer face and rotate the mixer cap to obtain a clear, stable blue flame with a distinct inner cone at each port. Excessive primary air causes "blowing" (the flames leaving the ports), while insufficient primary air causes a soft or yellow tipped flame.

The pilots are near the front of the burners, and are held in position by brackets. To adjust a pilot flame, insert a screwdriver through the opening in the valve panel between the control knobs and turn the appropriate pilot adjustment screw counterclockwise to increase the size of the pilot flame, or clockwise to decrease the size of the pilot flame. The maximum flame size is approximately 3/4" with a slight yellow tip. The first indication of over-adjustment is when the flame tip becomes more yellow and begins to generate carbon, which appears as rising black streaks. Continued over-adjustment leads to unstable lifting and a blowing condition.

CALIBRATION OF GAS OVEN THERMOSTAT

The oven thermostat control is carefully calibrated at the factory so that its dial settings closely match actual oven temperatures. Field recalibration is seldom necessary, and should not be resorted to unless considerable experience with unexpected cooking results definitely proves that the control is not maintaining the temperatures to which the dial is set.

When checking the oven temperature, use a test instrument or a reliable mercury thermometer positioned in the center of the oven. The oven bottom must be in place. For convection ovens, the blower baffle must be in place.

Proceed as follows:

1. Light the oven pilot, set the oven thermostat to 350°F, and, if the oven is a convection oven, turn on the fan.
2. After burner has been on about 15 minutes, check the oven temperature. The oven door should be open for as short a time as possible. Use a flashlight, if necessary, to see the thermometer clearly.
3. Continue to check temperature noting the minimum and maximum "swing" variation in temperature until two successive readings are within 5 degrees of each other. The oven temperature is the midpoint of the "swing" range.

The control should be recalibrated if your reading is not within 20 degrees of the dial setting (350°F). If calibration is required, the additional steps to be taken are these:

4. Insert a flat screwdriver through the center of the thermostat stem and then turn the adjustment screw clockwise to decrease the oven temperature and counterclockwise to increase the oven temperature. Do not allow the stem to turn. Turn the adjustment screw only 5 degrees of rotation in the appropriate direction, then repeat Steps 2 and 3 to check the temperature. Repeat until the temperature is within 10 degrees of 350°F.
5. Set the oven thermostat to 400°F. Check oven temperature again, as instructed in Steps 2 and 3. If the oven temperature is not within 20 degrees of the dial setting (400°F) it means that the sensing element is inoperative and the control should be replaced.

ADJUSTMENT OF THERMOSTATIC GRIDDLE BYPASS FLAME LEVEL

When the griddle reaches the temperature at which the dial is set, the control cuts down the flow of gas to the amount required to keep the griddle at that temperature. Always, however, the control must bypass enough gas to keep the entire burner lit. To maintain this minimum flame, *the bypass must be set carefully and accurately*, as follows (see Figure 12 on page 29):

1. Light the burner, then turn dial FULL ON.
2. After 5 minutes, turn dial clockwise to point slightly beyond first mark on dial.
3. Remove dial and bezel.
4. With a screwdriver, turn Bypass Adjustor (counterclockwise to increase the flame, clockwise to decrease it) until there is a minimum flame over the entire burner.
5. Replace bezel and dial, turning the dial clockwise until it locks in the OFF position.

CALIBRATION OF THERMOSTATIC GRIDDLE THERMOSTAT

The griddle temperature control is carefully calibrated at the factory—that is, it is so adjusted that dial settings match actual temperatures. Field recalibration is seldom necessary, and should not be resorted to unless considerable experience with cooking results definitely proves that the control is not maintaining the temperatures to which the dial is set.

Recalibration should not be undertaken, however, until the griddle bypass flame has been adjusted (see previous subsection).

To check temperatures when recalibrating, use a test instrument with a DISC type thermocouple for surface temperature checking. Drop a couple of drops of oil on griddle surface plate and place thermocouple disc flat into the oil.

Proceed as follows (see Figure 12 below):

1. Remove dial and push out metal insert.
2. Replace dial, turn to 350°F (175°C) mark, and light burner.
3. After burner has been on about 15 minutes check temperature.

- Continue to check temperature, at 5-minute intervals, until two successive readings are within 5°F (3°C) of each other.

The control should be recalibrated if your reading is not within 20°F (11°C) of the dial setting (350°F or 175°C). If calibration is required, the additional steps to be taken are these:

- Hold dial firmly, insert screwdriver through center of dial, and push calibration stem inward. **DO NOT TURN THIS STEM.**
- While holding calibration stem in firmly with screwdriver, turn dial until it is set at the actual oven temperature as shown by your test instrument. Release pressure on calibration stem. Replace dial insert.
- Set dial at 400°F (205°C) mark. Check temperature again, as instructed in steps 3 and 4. If the temperature is not within 20°F (11°C) of the dial setting (400°F or 205°C), it means that the sensing element is inoperative and the control should be replaced.

Figure 12

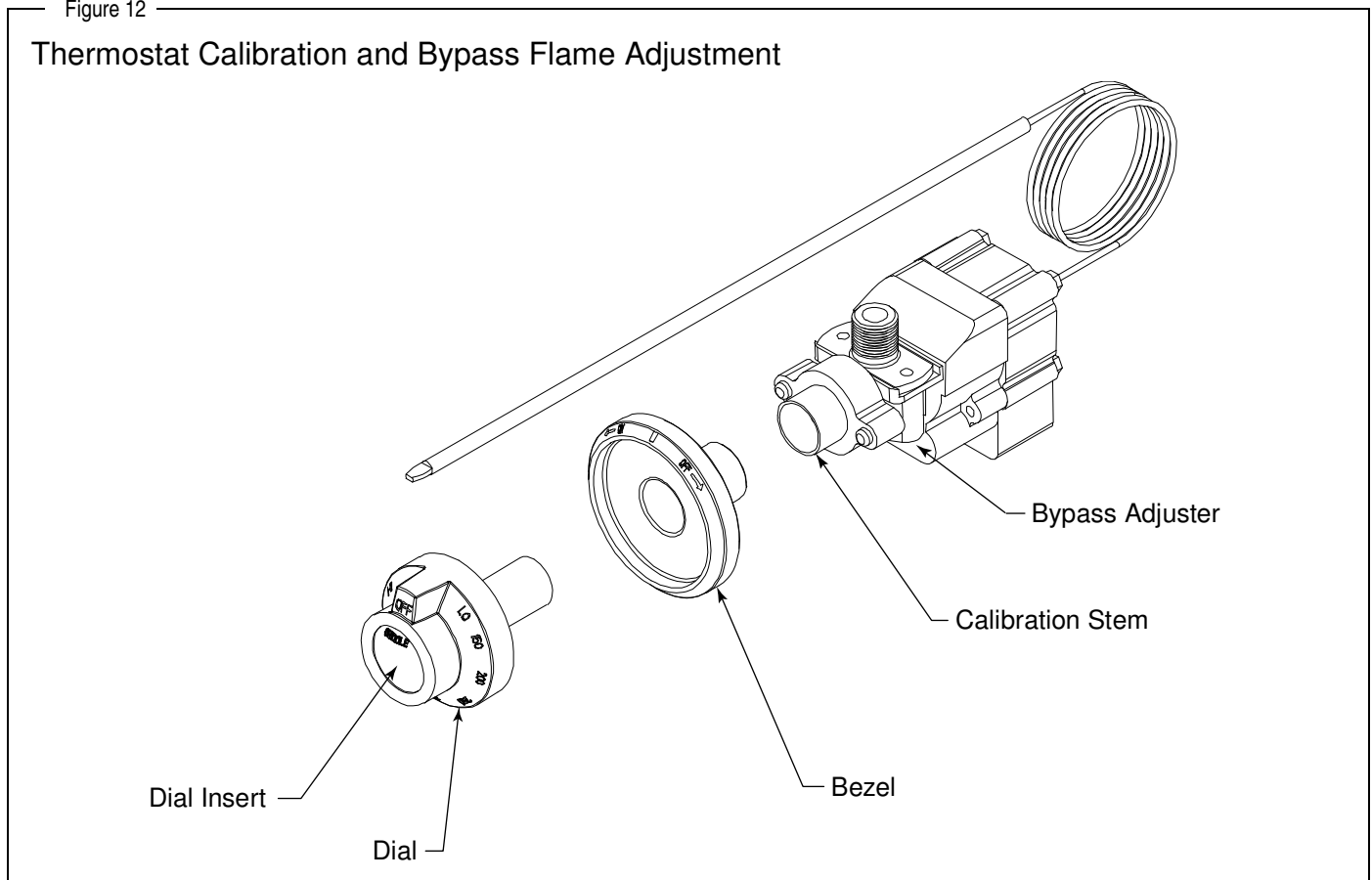

CONVERSION FROM ONE TYPE OF GAS TO ANOTHER

Each range is shipped adjusted and equipped for a specific type of gas (either natural gas or propane). To convert a range from one type of gas to another, do the following:

- Refer to service procedures to access all burner orifices.
- Refer to instructions included with conversion kit.
- Follow all steps as indicated in the conversion kit.
- Check for leaks and proper manifold pressure (the procedure is on page 26).
- Re-light all pilots and check for proper operation.

Note: A kit for conversion to a different type of gas may be purchased from Southbend.

Figure 13

Wiring Diagram for Gas Oven

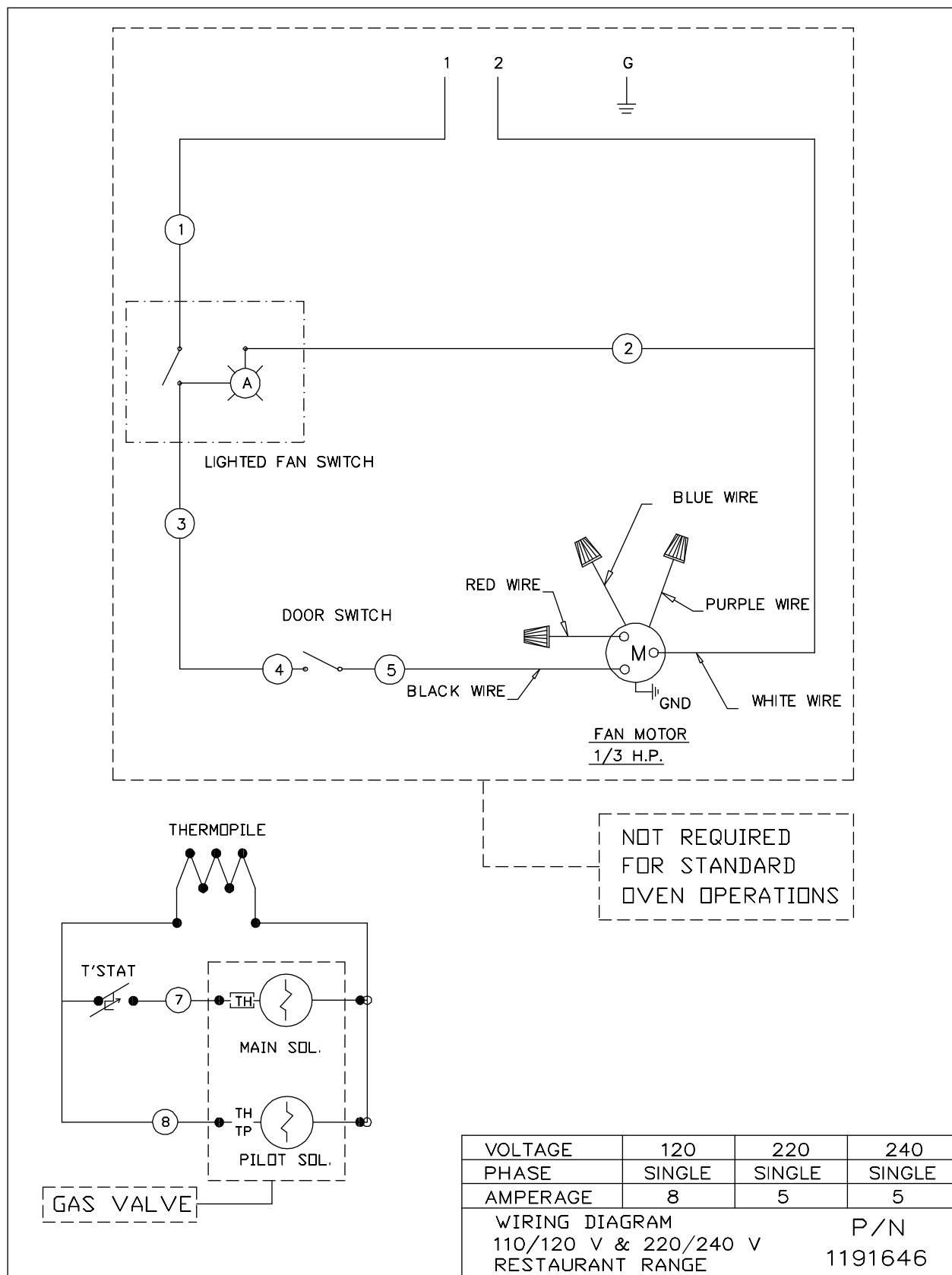

Figure 14

Wiring Diagram for Infrared Broiler in Gas Oven Cavity

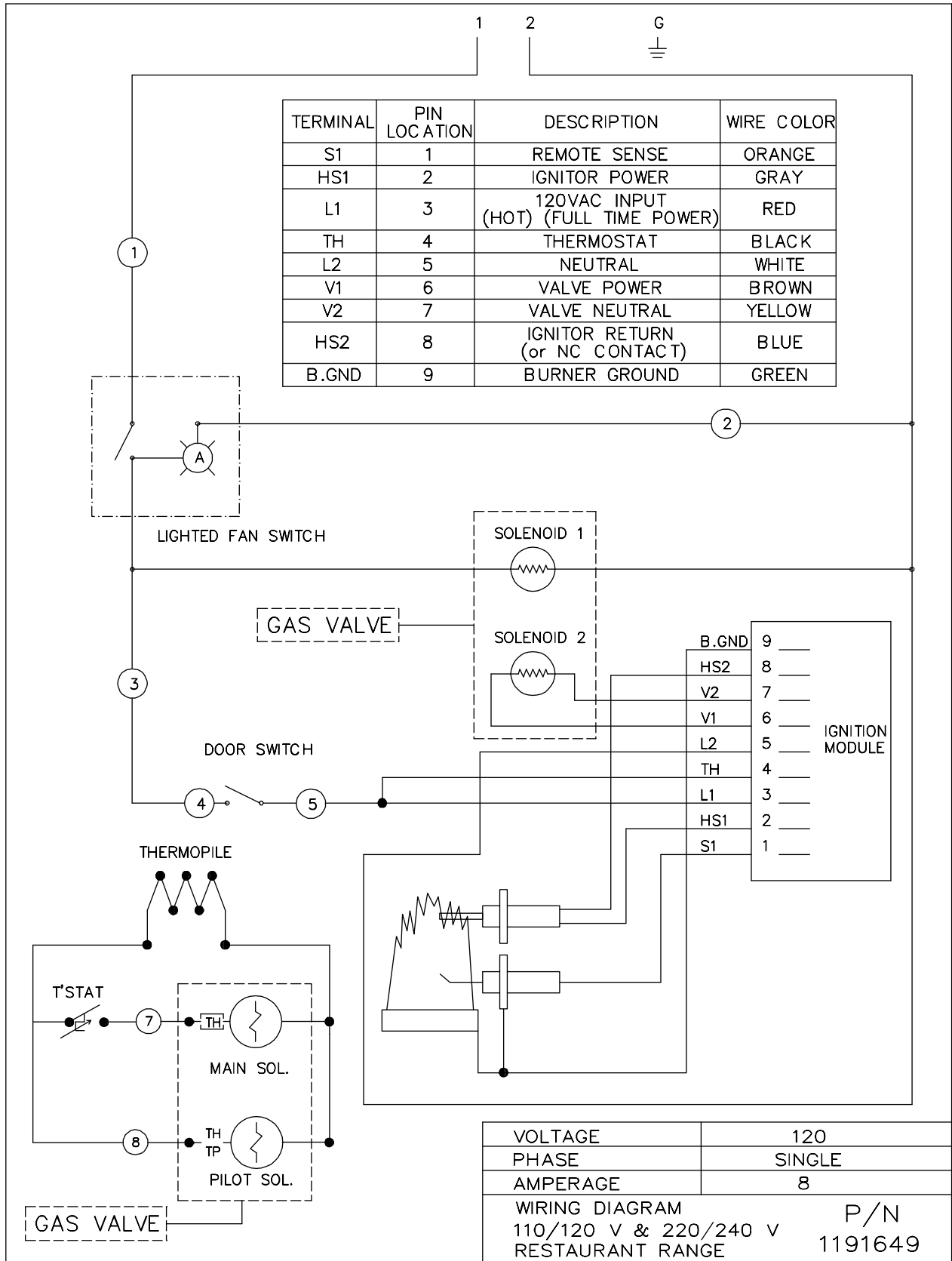

Figure 15

Wiring Diagram for Electric Standard Oven

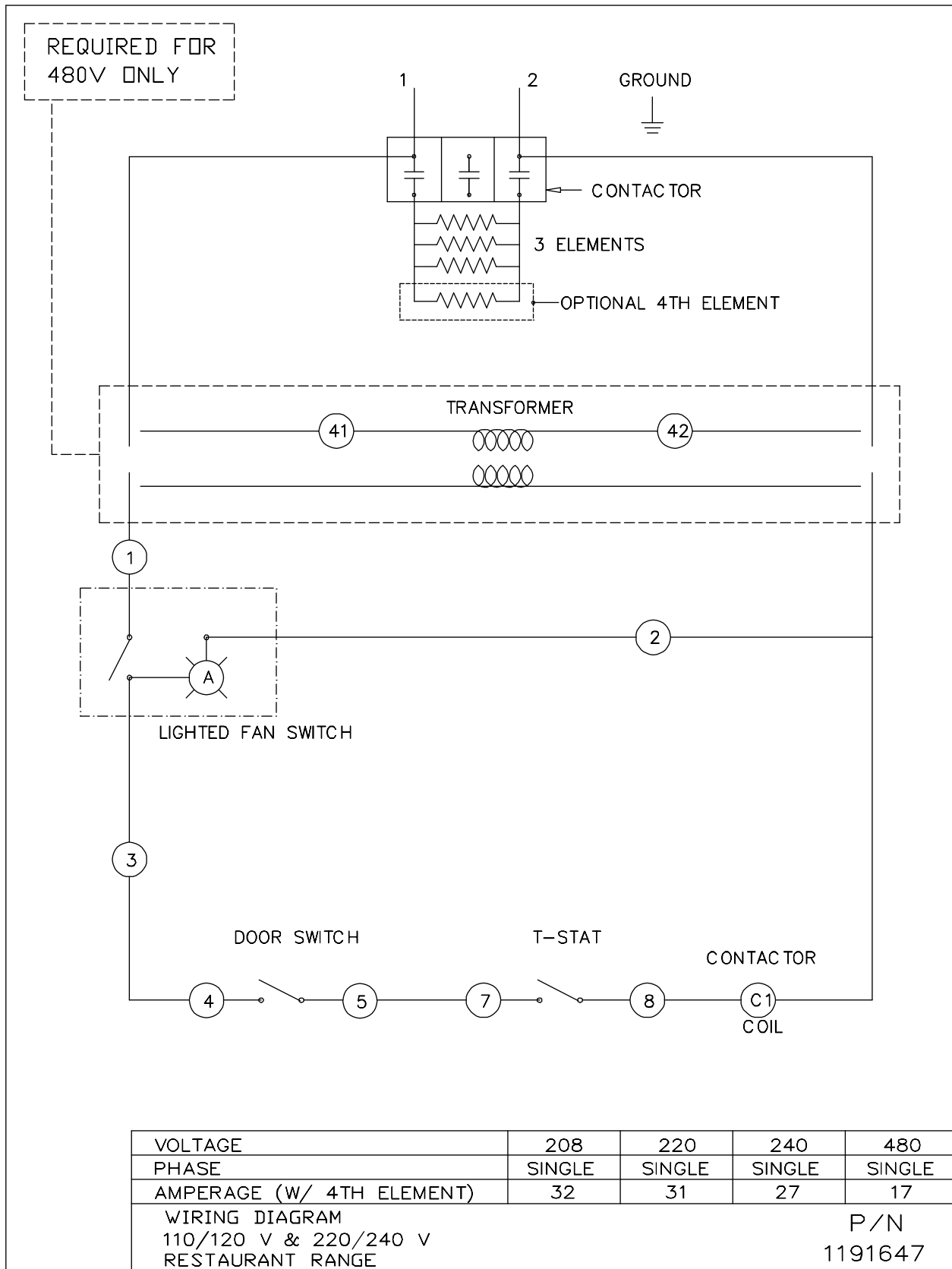
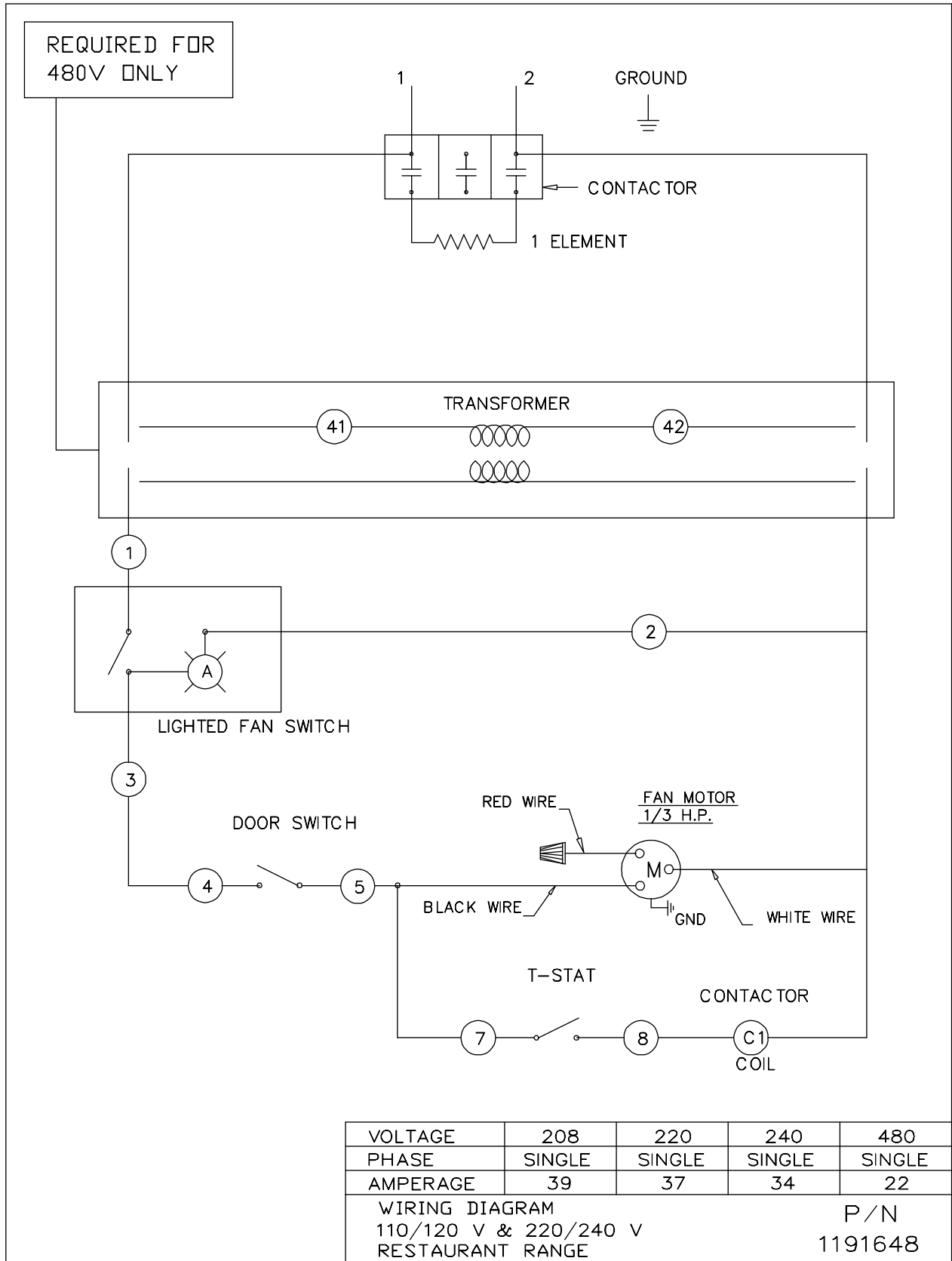

Figure 16

Wiring Diagram for Electric Convection Oven



PARTS

NOTICE

INSTALLATION OF OTHER THAN GENUINE SOUTHBEND PARTS WILL VOID THE WARRANTY ON THIS EQUIPMENT.

The following parts diagrams list and show serviceable parts. For parts not listed, contact a Southbend Authorized Parts Distributor or a Southbend Authorized Service Agency.

Parts Diagram	Page
Leg and Caster Parts	34
Control, Pilot, and Oven Door Parts	35
Top Burners and Grates Parts	36
Gas Oven Parts	37
Electric Oven Parts	38
Oven Broiler Parts	39
Griddle Parts	40
Raised Griddle Broiler Parts	41
Hot Top Parts	42
Charbroiler Parts	43

Figure 17

Leg and Caster Parts

Figure 18

Control, Pilot, and Oven Door Parts

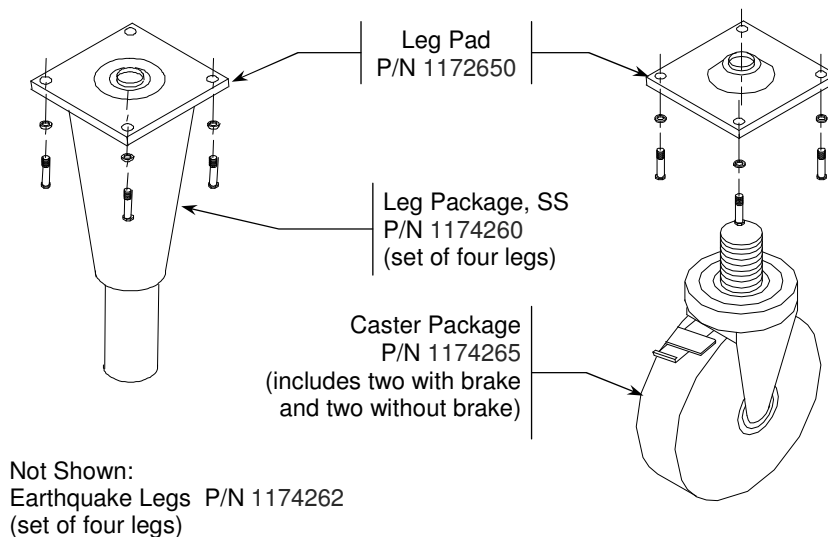
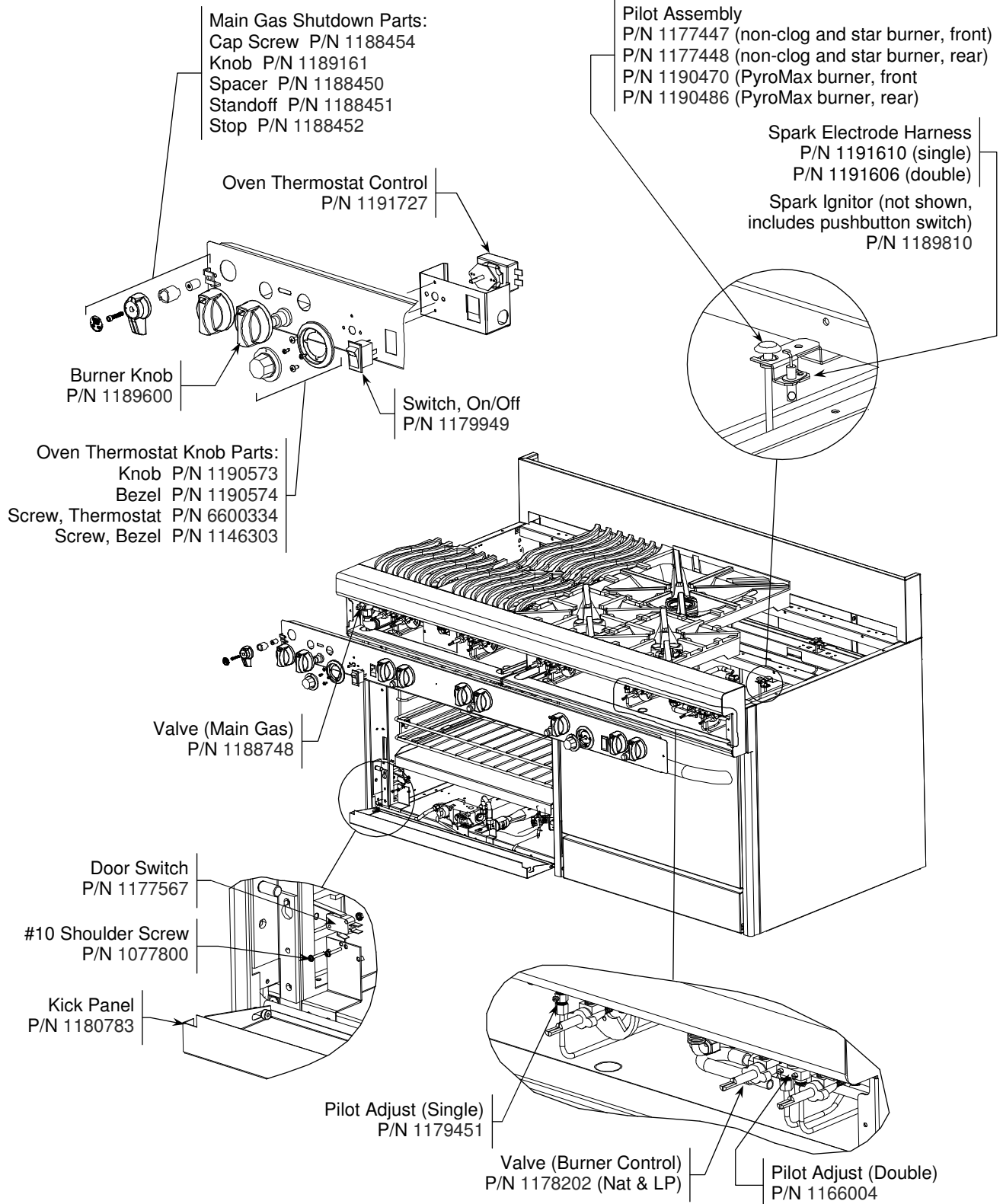
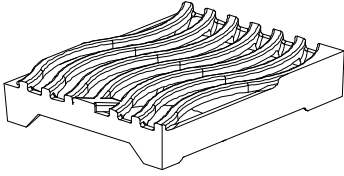

Figure 19

Top Burners and Grates Parts

Wavy Grate, Front P/N 1187488
Wavy Grate, Rear P/N 1187489



Non-Clog Burner (front & rear)
P/N 1177111

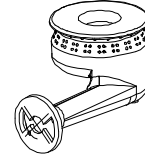

Standard Grate, Front P/N 1190551
Standard Grate, Rear P/N 1190552

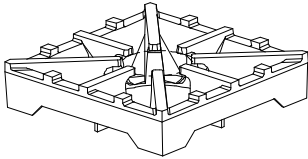

Star Burner (front & rear) P/N 1190485

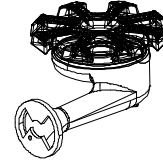

PyroMax Grate, Front P/N 1190553
PyroMax Grate, Rear P/N 1190554

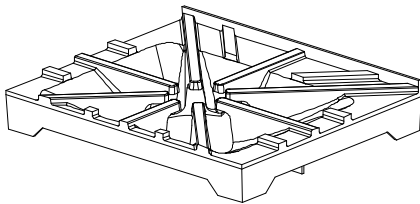

PyroMax Burner, Front P/N 1190571
PyroMax Burner, Rear P/N 1190572

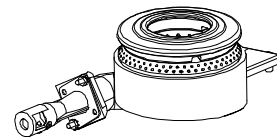
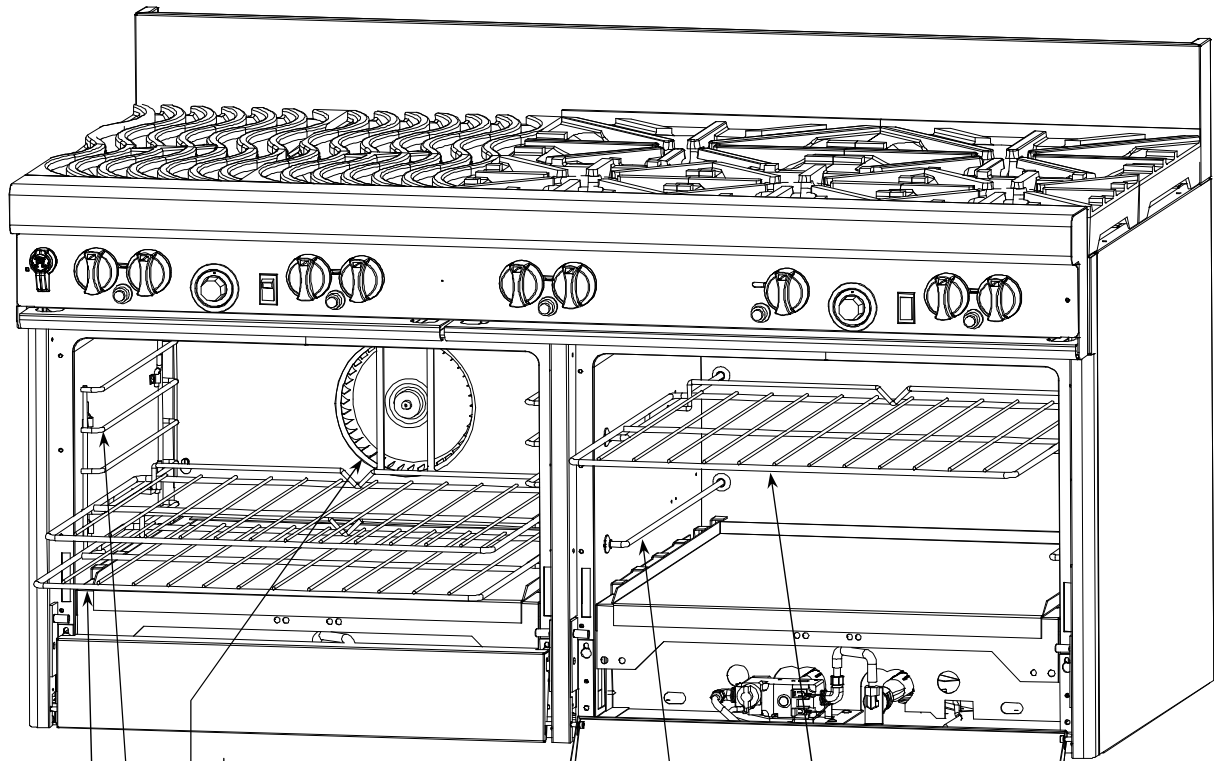

Figure 20

Gas Oven Parts



Blower Wheel
P/N 1177520

Rack Guide, Convection Oven
P/N 1180528

Rack, Convection Oven
P/N 1179920

Rack, Standard Oven
P/N 1173545

Rack Guide, Standard Oven
P/N 1187571

Gas Safety Valve
P/N 1190648

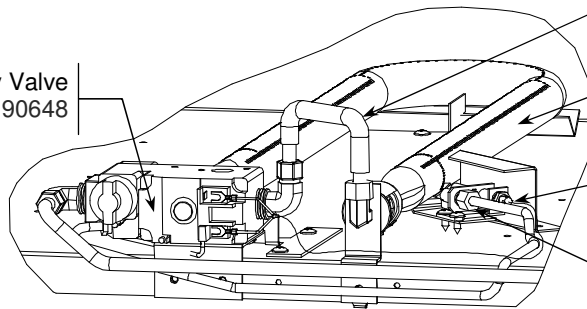

Flex Gas Tube
P/N 1187477

Oven Burner
P/N 1190568

Thermopile
P/N 1182154

Pilot Assembly
P/N 1163869 (Nat)
P/N 1163870 (LP)

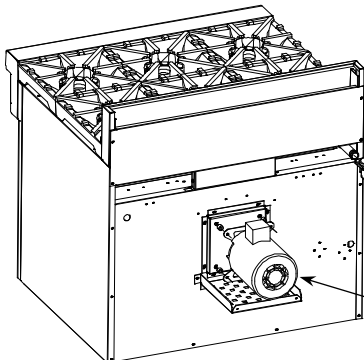

Gas Regulator
24", 36", and 48" Wide Units, Nat & LP P/N 1178815
60" Wide Units, Nat P/N 1181076
60" Wide Units, LP P/N 1181077

Convection Oven Motor
120V P/N 1188523
240V P/N 1179688

Figure 21

Electric Oven Parts

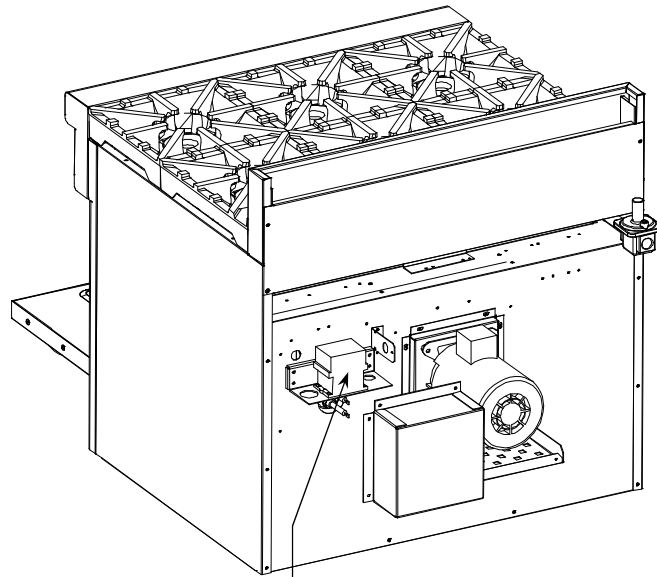

Element Contactor P/N 1179680
Same for standard and convection ovens.

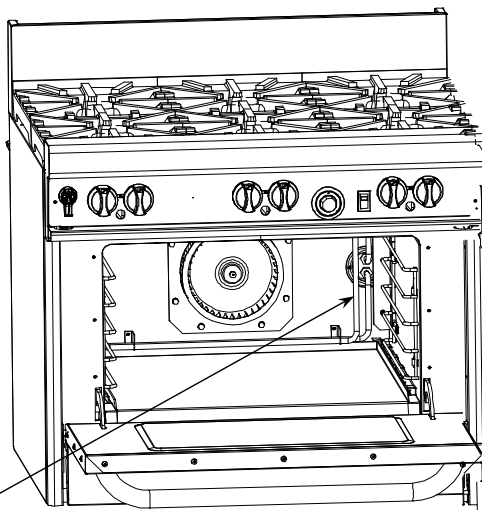

Electric Element (Convection Oven)
208V P/N 3027A0063
240V P/N 3027A8711
480V P/N 3027A8709
Element is behind oven baffle (not shown).

Other electric oven parts are the same as for gas ovens.

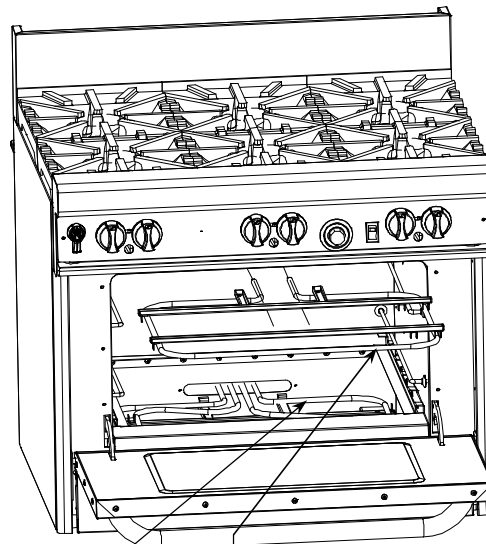

Top Element (Standard Oven)
208V P/N 1191621
240V P/N 1191622
480V P/N 1191625

Bottom Element (Standard Oven)
208V P/N 7608881
240V P/N 7608882
480V P/N 7608885
Bottom element is below oven-bottom baffle (not shown).

Figure 22

Oven Broiler Parts

Not Shown:
Switch On/Off
P/N 1179949

Infrared Burner P/N 1190733
Ceramic Tile P/N 1163578
Fibre-Fax P/N 1057515

Hot Surface Ignitor/
Flame Sensor Assembly
P/N 1190650

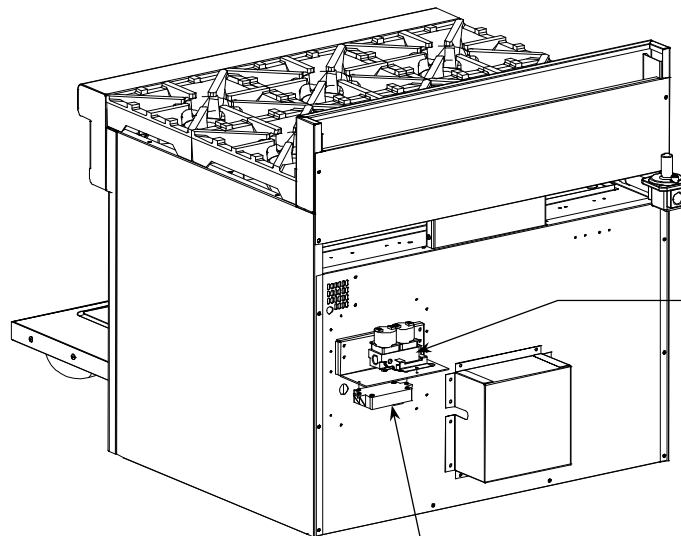
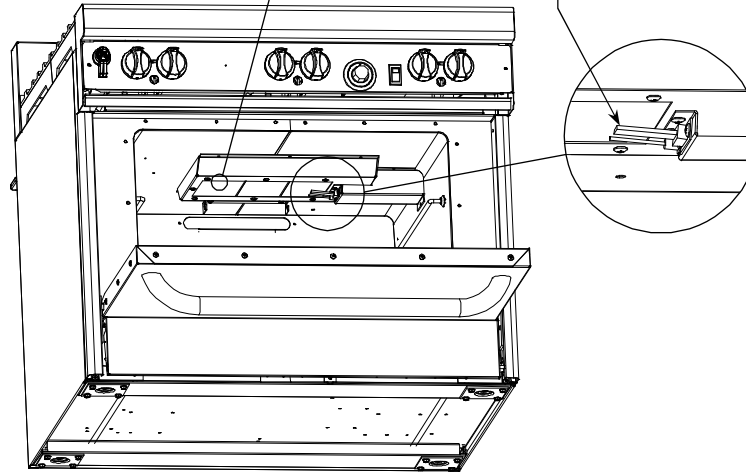

Solenoid Gas Valve
P/N 1185533

Ignition Control Module
P/N 1190642

Figure 23

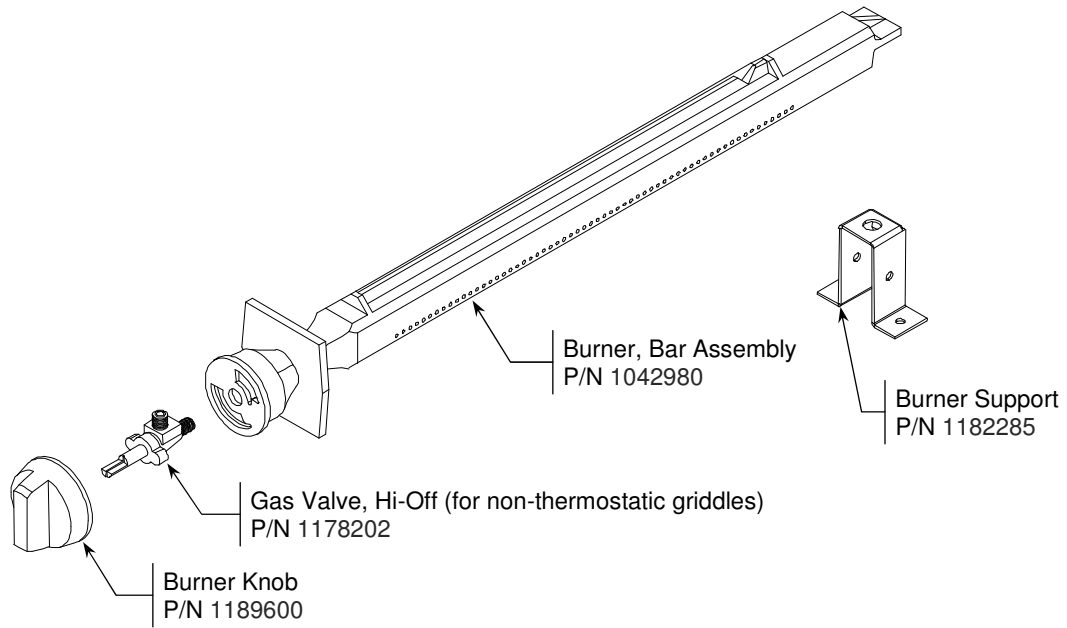
Griddle Parts**Not Shown:**

- Pilot Adjustment Valve (for 12" griddle) P/N 1099002
- Pilot Adjustment Valve (for 24", 36", and 48" griddles) P/N 1163844
- Grease Drawer Assembly P/N 1186275
- Thermostat (for thermostatic griddles) P/N 1174709
- Thermostat Knob (for thermostatic griddles) P/N 1179997

Figure 24

Raised Griddle Broiler Parts

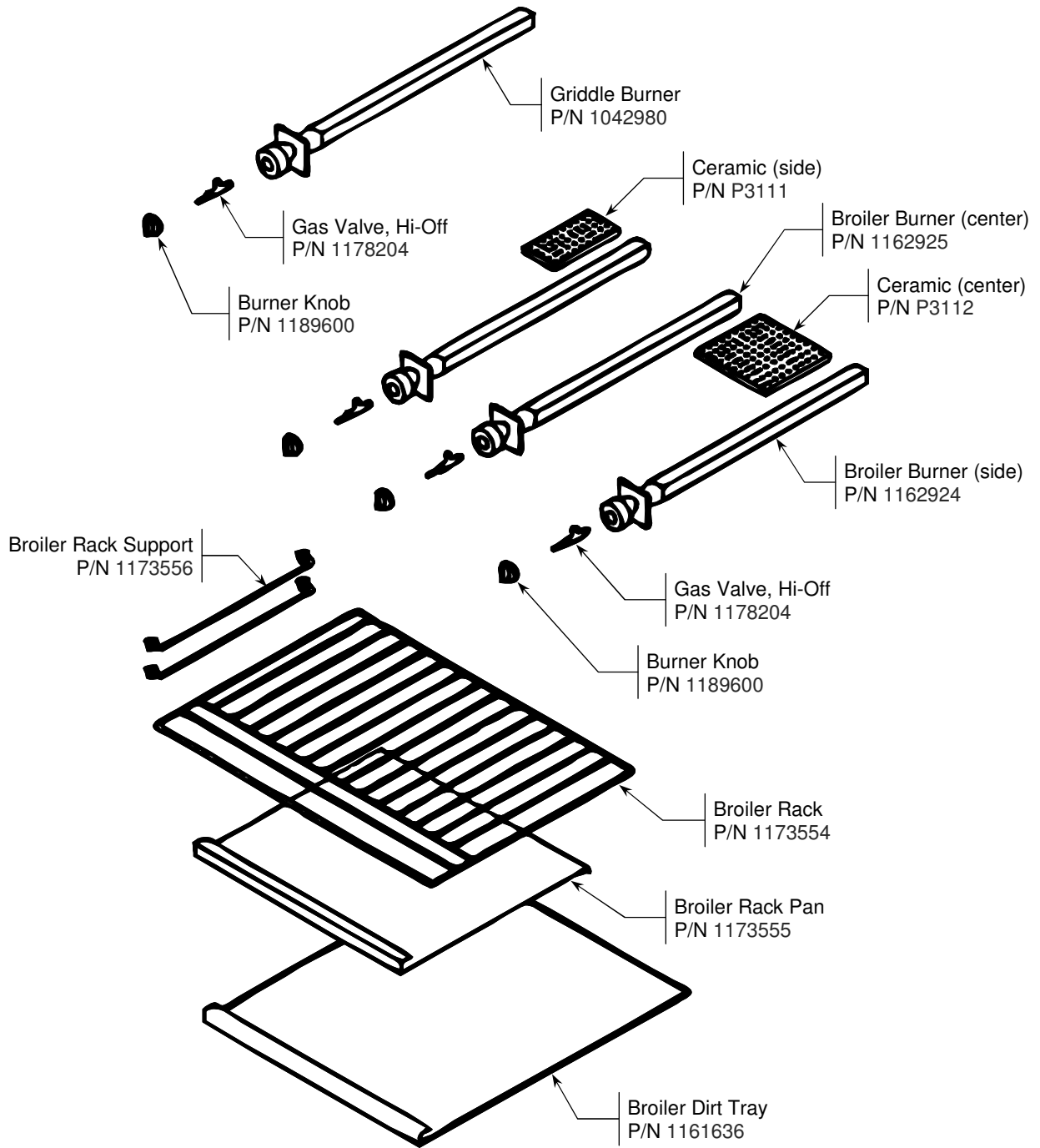

Not Shown:
Pilot Adjustment Valve P/N 1163844
Grease Chute P/N 1043699

Figure 25

Hot Top Parts

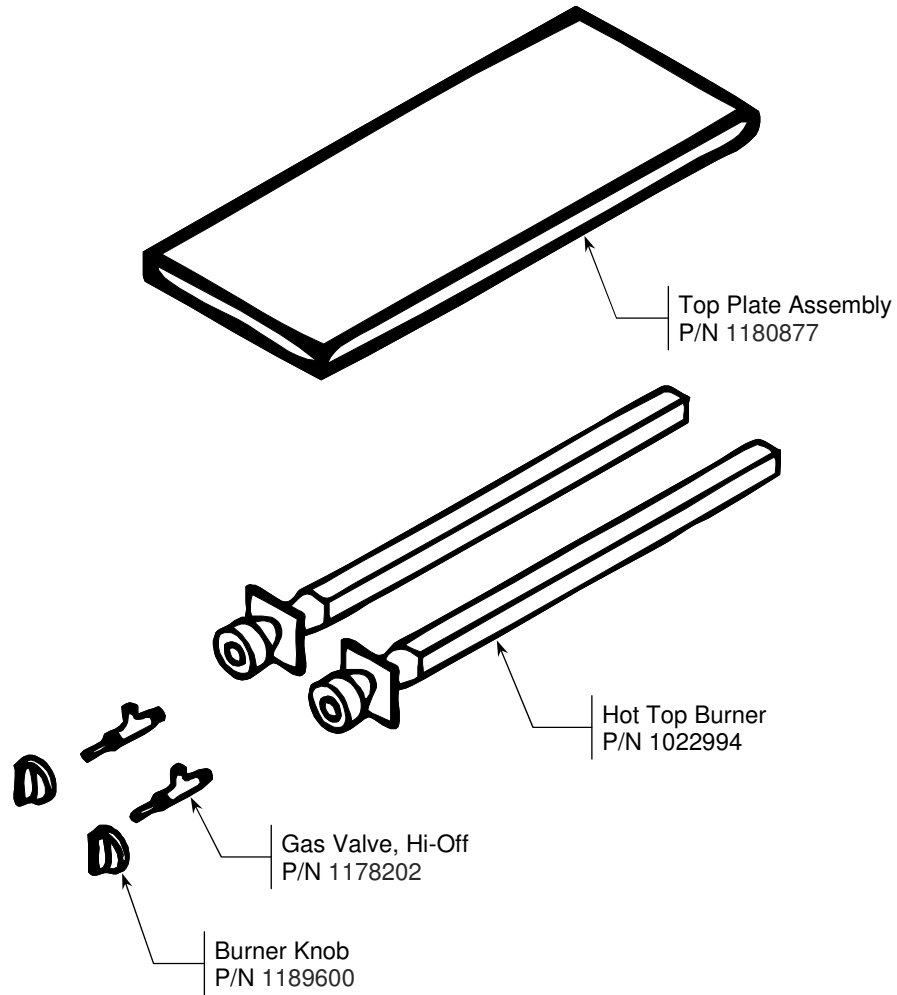

Not Shown:
Pilot Adjustment Valve P/N 1099002

Figure 26

Charbroiler Parts

Charbroiler Grid P/N 1178976

Not Shown:
Plated Fish Grid P/N 1182838

Grate P/N 1182657

Radiant W/A P/N 1192319

Burner Assembly, Charbroiler
P/N 1182762

Tube W/A, Char, Left Pilot
P/N 1192416

Bracket, Pilot
P/N 1187594

Tube W/A, Char, Right Pilot
P/N 1192418

Valve, Burner, Nat
P/N 1178202

Fitting, Double Pilot, 3/16" Tube
P/N 1166004

Not Shown:
Burner Knob P/N 1189600

Notes:



Notes:

Notes:

Notes:

ULTIMATE RESTAURANT RANGES



A product with the Southbend name incorporates the best in durability and low maintenance. We all recognize, however, that replacement parts and occasional professional service may be necessary to extend the useful life of this appliance. When service is needed, contact a Southbend Authorized Service Agency, or your dealer. To avoid confusion, always refer to the model number, serial number, and type of your appliance.



Southbend
1100 Old Honeycutt Road, Fuquay-Varina, NC 27526
www.southbendnc.com