

**PS555
USA & Std. Export**

PS555 Gas Oven

PARTS MANUAL

for domestic and standard export ovens

© 2000 Middleby Marshall, Inc.

 **Middleby
Marshall®** is a registered trademark of Middleby Marshall, Inc. All rights reserved.

Middleby Cooking Systems Group • 1400 Toastmaster Drive • Elgin, IL 60120 • (847)741-3300 • FAX (847)741-4406

TABLE OF CONTENTS

<i>Section</i>	<i>Page</i>
I. KEY SPARE PARTS KIT	3
II. INSTALLATIONKIT	4
III. BASE PAD KIT	4
IV. OVEN PANELS, WINDOW AND LEGS	6
V. CONTROL PANEL AND MACHINERY COMPARTMENT	8
VI. SIDE COMPARTMENTS	10
VII. BLOWER ASSEMBLIES AND BLOWER MOTORS	12
VIII. GAS BURNER SYSTEM	14
IX. CONVEYOR ASSEMBLY, SINGLE-BELT OVENS	16
X. CONVEYOR ASSEMBLY, SPLIT-BELT OVENS	18

NOTE: Throughout this Parts Manual, the following abbreviations are used:

A/R = Quantity As Required

N/A = Does Not Apply

WARNING

FOR YOUR SAFETY DO NOT STORE OR USE GASOLINE OR OTHER FLAMMABLE VAPORS AND LIQUIDS IN THE VICINITY OF THIS OR ANY OTHER APPLIANCE

WARNING

Improper installation, adjustment, alteration, service or maintenance can cause property damage, injury or death. Read the installation, operating and maintenance instructions thoroughly before installing or servicing this equipment.

WARNING

DISCONNECT THE OVEN FROM ITS ELECTRICAL POWER SUPPLY BEFORE SERVICING.

NOTICE

Using any parts other than genuine Middleby Marshall factory manufactured parts relieves the manufacturer of all warranty and liability.

NOTICE

Middleby Marshall (Manufacturer) reserves the right to change specifications at any time.

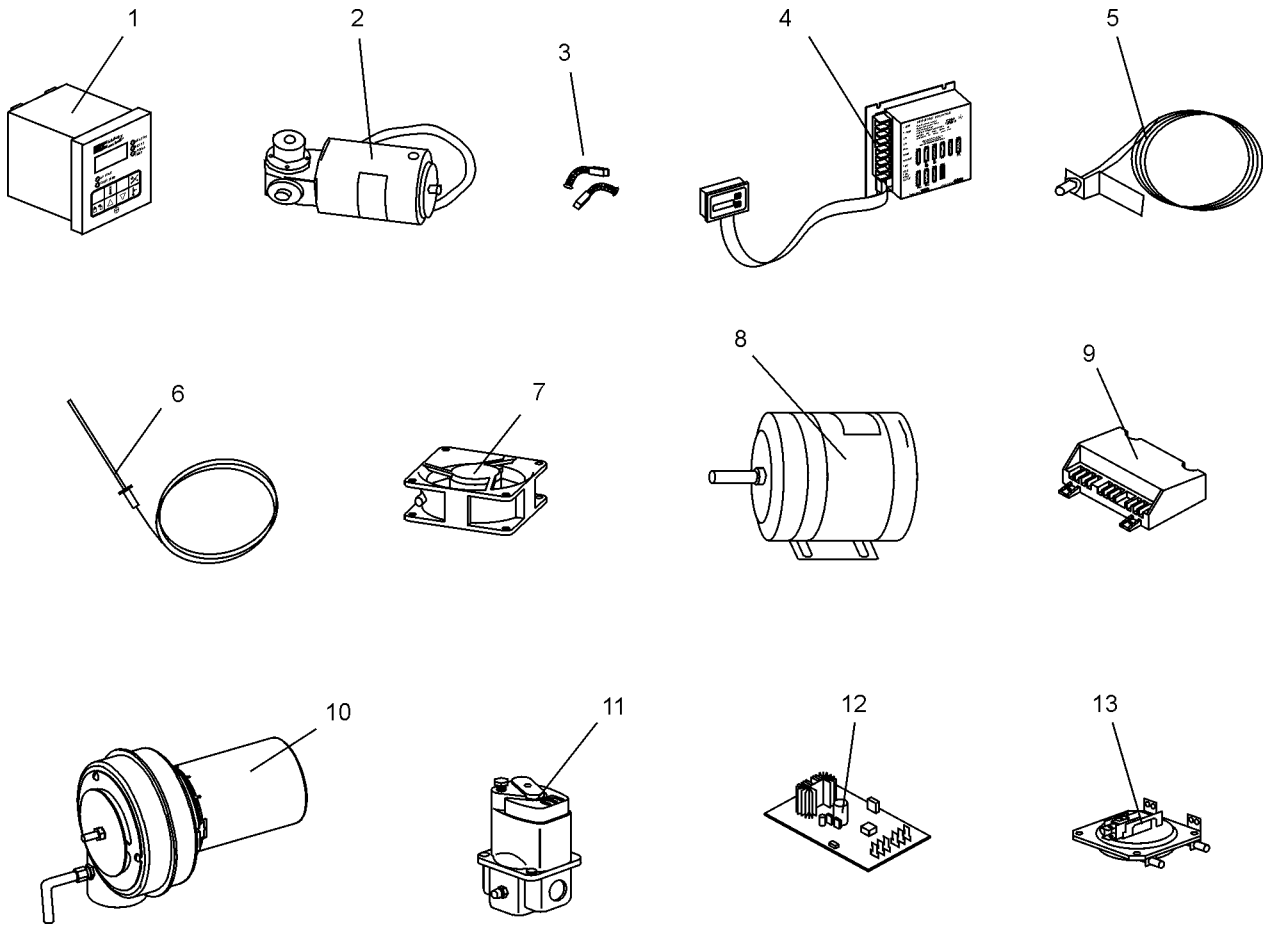

PS555
USA & Std. Export

I. KEY SPARE PARTS KIT

ITEM	QTY.	P/N	DESCRIPTION
1	1	36939	KIT, DIGITAL TEMPERATURE CONTROL
2	1	27384-0008	MOTOR, DRIVE
3	2	22450-0052	BRUSH, DRIVE MOTOR
4	1	37337	KIT, CONVEYOR SPEED CONTROLLER WITH DIGITAL DISPLAY
5	1	27170-0263	ASSEMBLY, PICKUP, DRIVE MOTOR
6	1	33984	KIT, THERMOCOUPLE
7	1	97525	FAN, COOLING
8	1	27381-0069	MOTOR, BLOWER, 1 HP
9	1	42810-0114	KIT, IGNITION MODULE
10	1	38811	BURNER BLOWER/MOTOR ASSEMBLY
11	1	41647	VALVE, MODULATING GAS, 1/2"
12	1	31651	AMPLIFIER, MODULATING VALVE
13	1	39530	AIR SWITCH

INSTALLATION KIT

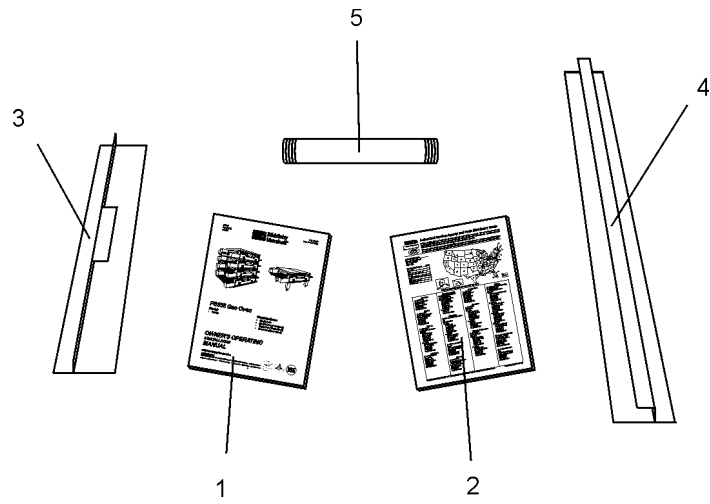

BASE PAD KIT

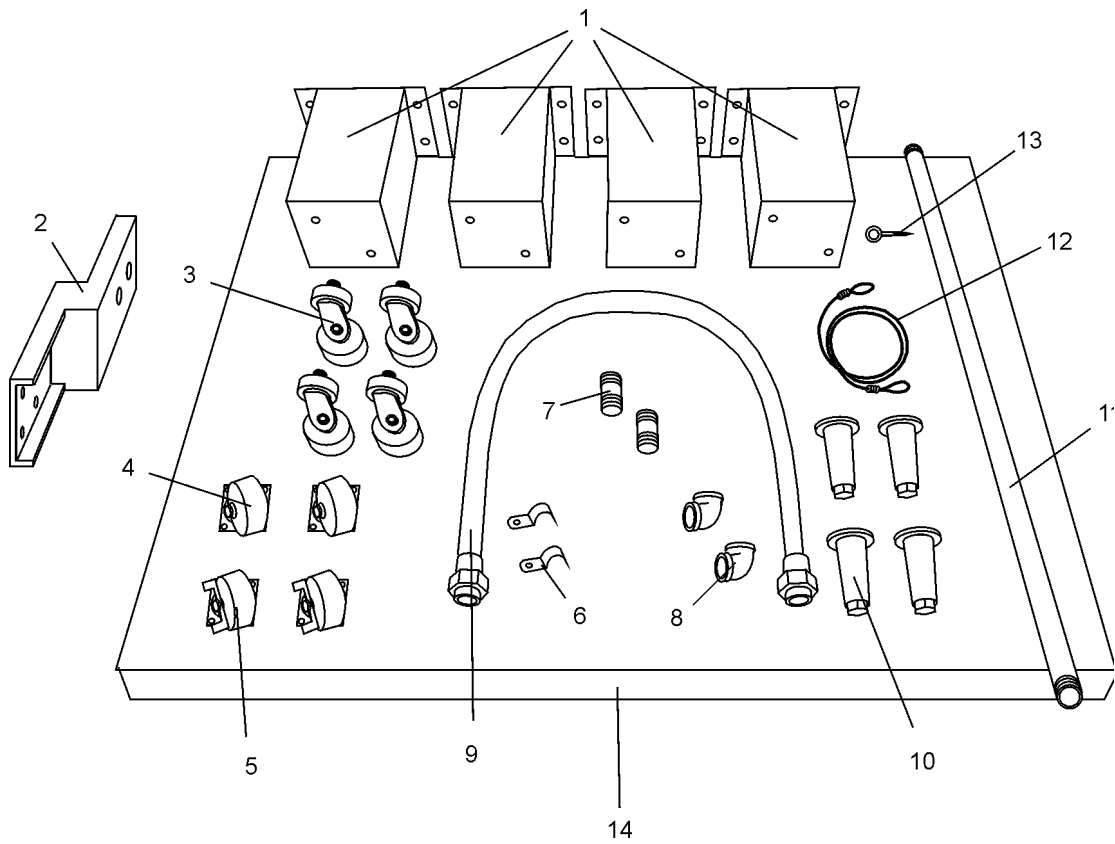

II. INSTALLATION KIT

ITEM	QTY. - SGL. BELT	QTY. - SPLIT BELT	P/N	DESCRIPTION
1	1	1	43339	OWNER'S OPERATING AND INSTALLATION MANUAL, PS555 OVEN (DOMESTIC AND STANDARD EXPORT VERSIONS - ENGLISH)
2	1	1	1002040	AAUTHORIZED SERVICE AGENCY LISTING/DISTRIBUTOR'S GUIDE
3	1	1	35900-0148	CONVEYOR REAR STOP
4	1	1	35000-1103	CONVEYOR END STOP
5	1	1	33120-0053	GAS PIPE NIPPLE

III. BASE PAD KIT

ITEM	QTY. SINGLE OVEN	QTY. - DBL. OVEN W/ 10" LEGS	QTY. - DBL. OVEN W/ 15" LEGS	QTY. TRIPLE OVEN	QTY. QUAD OVEN	P/N	DESCRIPTION
1a	4	--	--	--	--	37210-0060	LEG, 19" (483mm)
1b	--	4	--	--	--	37210-0082	LEG, 10" (254mm)
1c	--	--	4	--	--	37210-0057	LEG, 15" (381mm)
1d	--	--	--	4 (optional)	--	43158	LEG, 4" (102mm)
2	--	--	--	--	4	37210-0054	OUTRIGGER
3	4	4	4	4	--	37115-0102	CASTER, SWIVEL WITH 3/4" STUD
4	--	--	--	--	2	22290-0010	CASTER, SWIVEL WITH PLATE (W/O BRAKE)
5	--	--	--	--	2	22290-0009	CASTER, SWIVEL WITH PLATE & BRAKE
6	2	2	2	2	2	27271-0004	PIPE CLAMP, 1-1/2"
7	2	2	2	2	2	33120-0055	NIPPLE, 1-1/4" DIA. X 3" L, NPT
8	2	2	2	2	2	23122-0007	ELBOW, 90°, 1-1/4" DIA.
9	1	1	1	1	1	22361-0003	GAS HOSE, 1-1/4" DIA. X 72" L
10	4	4	4	4	--	22450-0028	LEG, 6" (152mm) ADJUSTABLE WITH 3/4" STUD
11	1	1	1	1	1	33120-0056	GAS PIPE, 1-1/4" DIA. X 54" L
12	1	1	1	1	1	22450-0253	RESTRAINT CABLE, 60" (1524mm)
13	1	1	1	1	1	21392-0005	EYE BOLT/LAG SCREW
14b	2	2	2	2	2	41582	TOP COVER (RIGHT OR LEFT), PS555

NOT SHOWN:

--	1	1	1	1	1	41643	BASE PAD, PS555
--	8	8	8	8	8	21256-0069	SCREW, SLT TRS HD #10-32 X 1-1/4"
--	2	2	2	2	2	21292-0001	SCREW, TEKS HWH #2PT #10-16 X 3/4"
--	16	16	16	--	8	21216-0018	BOLT, HEX CAP 1/2"-13 X 1-1/4"
--	16	16	16	--	8	21416-0003	FLAT WASHER, 1/2"
--	16	16	16	--	8	21426-0004	LOCK WASHER, 1/2"
--	--	--	--	--	16	220373	SCREW, HEX HD 3/8"-16 X 1"
--	--	--	--	--	16	21416-0001	FLAT WASHER, 3/8"
--	--	--	--	--	16	21422-0001	LOCK WASHER, 3/8"

PS555
USA & Std. Export

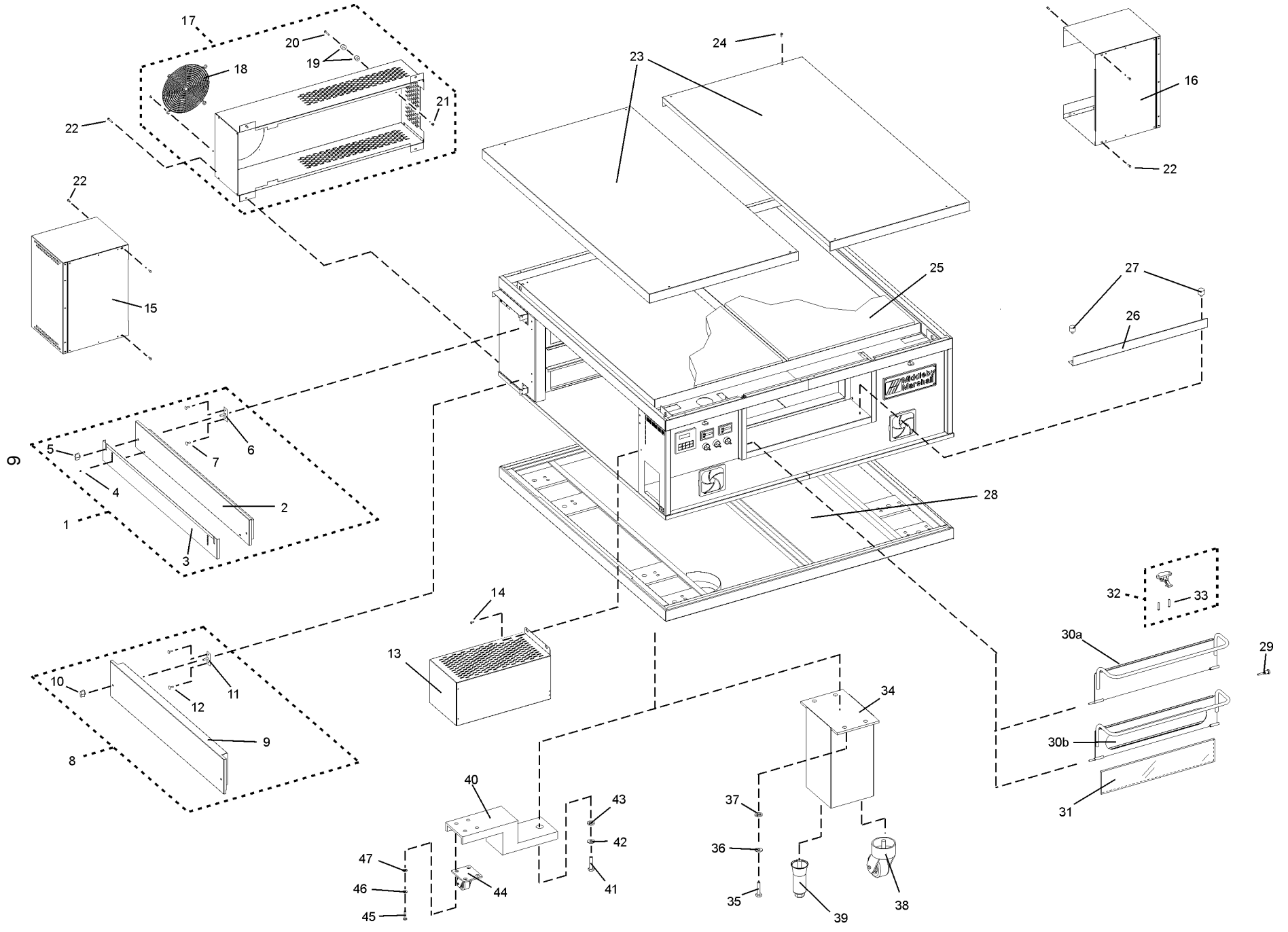

IV. OVEN PANELS, WINDOW AND LEGS

ITEM	QTY.	P/N	DESCRIPTION
1	2	39539	ASSY, UPPER END PLUG <i>(INC. ITEMS 2-7)</i>
2	1	41778	WELDMENT, UPPER END PLUG PS500
3	1	41738	EYEBROW
4	2	220295	SCREW, "AB" HEX WSHR HD #10 X 3/4"
5	2	36452	WING NUT, 1/4"-20 W/PLASTIC GRIP
6	2	41708	PLATE, END PLUG MOUNTING
7	4	21292-0001	SCREW, TEKS HWH #2PT #10-16 X 3/4"
8	2	39569	ASSY, LOWER END PLUG <i>(INC. ITEMS 9-12)</i>
9	1	41779	WELDMENT, LOWER END PLUG PS500
10	2	36452	WING NUT, 1/4"-20 W/PLASTIC GRIP
11	2	41708	PLATE, END PLUG MOUNTING
12	4	21292-0001	STUD, SELF-CLINCHING 1/4"-20 X 1"
13	1	44494	ASSEMBLY, DRIVE MOTOR SHROUD
14	2	A6153	SCREW, HEX HD 1/4"-20 X 1/2"
15	1	44482	ASSEMBLY, LEFT MOTOR SHROUD
16	1	44483	ASSEMBLY, RIGHT MOTOR SHROUD
17	2	41679	ASSEMBLY, REAR SHROUD <i>(INC. ITEMS 18-21)</i>
18	1	31765	GRILL, COOLING FAN
19	2	4021D8905	BUMPER
20	1	4111A8813	SCREW, SLT TRS HD #10-32 X 1-1/4"
21	1	F707A8803	HEX NUT, #10-32
22	A/R	4111A8815	SCREW, HEX HD #10-32 X 1/2"
23	2	41582	TOP COVER, PS555
24	8	21256-0069	SCREW, SLT TRS HD #10-32 X 1-1/4"
25	2	42554	INSULATION, ROOF PRECUT PS555
26	1	42488	WINDOW GUARD, PS555
27	2	30927	BUMPER, WINDOW
28	1	41643	BASE PAD, PS555

ITEM	QTY.	P/N	DESCRIPTION
29	1	34121-0003	SCREW, WINDOW PIVOT
30a	1	42542	WELDMENT - SOLID DOOR, HANDLE, & PIVOT PIN
30b	1	44485	WELDMENT - DOOR WITH WINDOW, HANDLE, & PIVOT PIN
31	1	41587	GLASS, WINDOW, PRE-CUT <i>(FOR USE WITH ITEM 30b)</i>
32	1	41790	ASSEMBLY, WINDOW LATCH <i>(INC. ITEM 33)</i>
33	2	19A1S144	SCREW, HEX HD #10-32 X 1-1/4"
34a	4	37210-0060	LEG, 483mm - SINGLE OVEN
34b	4	37210-0057	LEG, 381mm - DOUBLE OVEN
34c	4	37210-0082	LEG, 254mm - DOUBLE OVEN
34d	4	43158	LEG, 102mm - OPTIONAL FOR TRIPLE OVEN
35	16	21216-0018	BOLT, HEX CAP 1/2"-13 X 1-1/4" - SINGLE & DOUBLE OVENS
36	16	21426-0004	LOCKWASHER, 1/2" - SGL & DBL OVENS
37	16	21416-0003	FLAT WASHER, 1/2" - SGL & DBL OVENS
38	4	37115-0102	CASTER, SWIVEL WITH 3/4" STUD - SINGLE, DOUBLE, & TRIPLE OVENS
39	4	22450-0028	LEG, 6" (152mm) ADJUSTABLE WITH 3/4" STUD - SINGLE, DOUBLE, & TRIPLE OVENS
40	4	37210-0054	OUTRIGGER - QUAD OVEN
41	8	21216-0018	BOLT, HEX CAP 1/2"-13 X 1-1/4" - QUAD OVENS
42	8	21426-0004	LOCKWASHER, 1/2" - QUAD OVENS
43	8	21416-0003	FLAT WASHER, 1/2" - QUAD OVENS
44a	2	22290-0009	CASTER, SWIVEL WITH FLAT MOUNTING PLATE AND BRAKE - QUAD OVENS, FRONT
44b	2	22290-0010	CASTER, SWIVEL WITH FLAT MOUNTING PLATE (WITHOUT BRAKE) - QUAD OVENS, REAR
45	16	220373	SCREW, HEX HD 3/8"-16 X 1" - QUAD OVENS
46	16	21422-0001	LOCKWASHER, 3/8" - QUAD OVENS
47	16	21416-0001	FLAT WASHER, 3/8" - QUAD OVENS

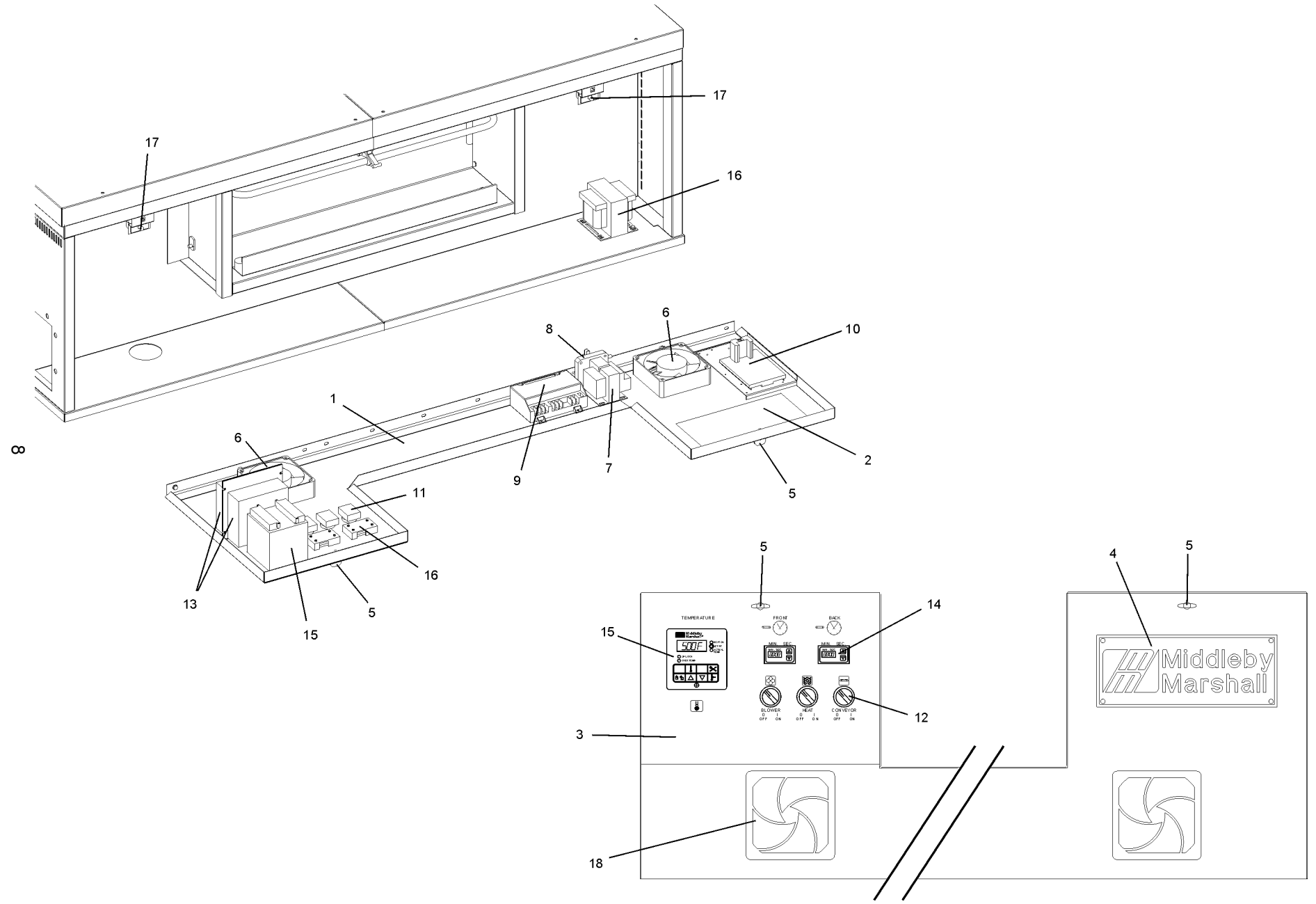

V. CONTROL PANEL AND MACHINERY COMPARTMENT

ITEM	QTY.	P/N	DESCRIPTION
1	1	41581	MACHINERY COMPARTMENT ACCESS PANEL, WITHOUT COMPONENTS
2	1	42646	LABEL, WIRING DIAGRAM
3	1	39464	LABEL, CONTROL PANEL
4	1	22500-0021	NAMEPLATE, "MIDDLEBY MARSHALL"
5	2	21296-0003	WING SCREW
6	2	97525	COOLING FAN
7	1	32108	TRANSFORMER, 240Vp:24Vs 65VA
8	1	39530	AIR SWITCH
9	1	42810-0114	KIT, IGNITION MODULE
10	1	31651	AMPLIFIER, MODULATING VALVE
11	3	42503	CONTACT BLOCK WITH BASE
12	3	37168	SELECTOR SWITCH WITH KNOB

ITEM	QTY.	P/N	DESCRIPTION
--	1	37337	KIT, CONVEYOR SPEED CONTROLLER WITH SELECTOR AND DIGITAL DISPLAY (<i>INC. ITEMS 13-14</i>)
13	1	37504	SPEED CONTROL MODULE ONLY
14	1	37503	DIGITAL DISPLAY
15	1	36939	KIT, DIGITAL TEMPERATURE CONTROLLER
16	1	31504	TRANSFORMER, 230Vp:120Vs 0.2 KVA
17	2	28021-0047	SAFETY SWITCH, MACHINERY COMPARTMENT ACCESS PANEL
18	2	27470-0004	GRILL, COOLING FAN

NOT SHOWN:

--	2	37842	FILTER, FOAM, COOLING FAN
--	2	33984	KIT, THERMOCOUPLE

6

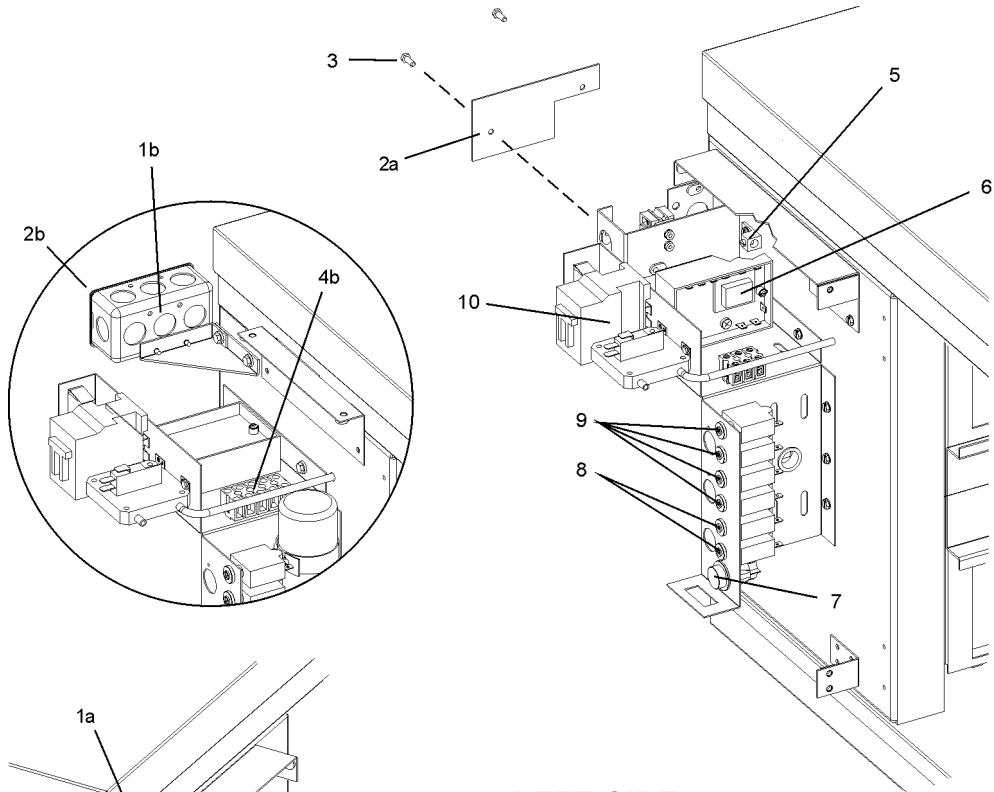

LEFT SIDE

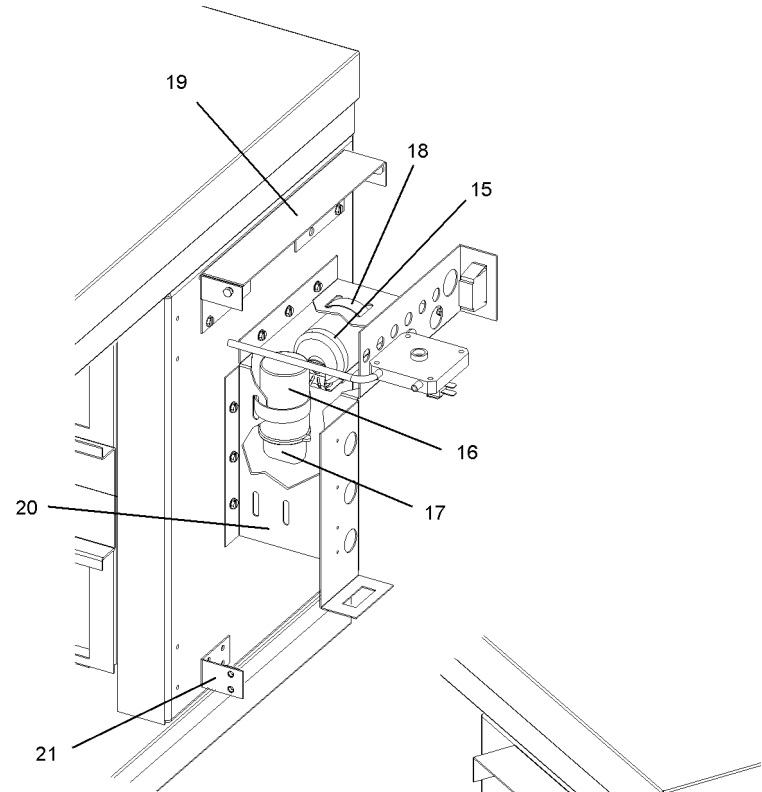

RIGHT SIDE

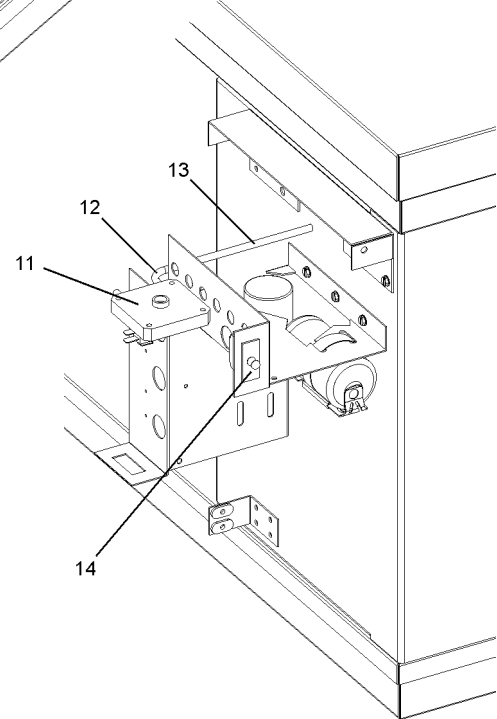
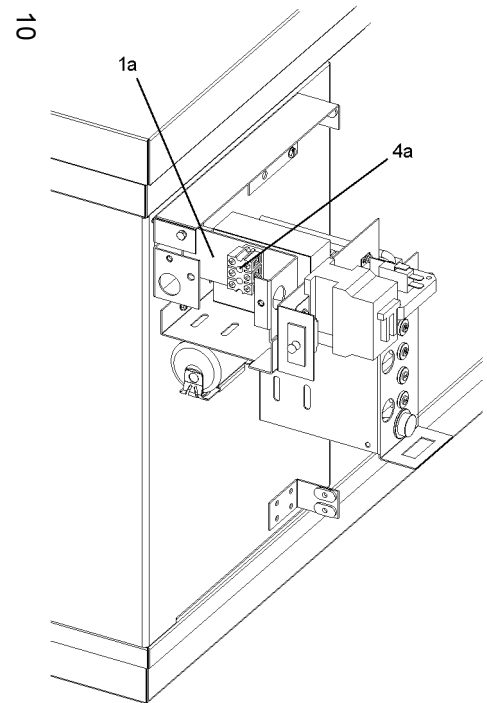

VI. SIDE COMPARTMENTS

ITEM	QTY.	P/N	DESCRIPTION
1a	1	44463	ELECTRICAL JUNCTION BOX (CURRENT)
1b	1	41735	ELECTRICAL JUNCTION BOX (ORIGINAL DESIGN)
2a	1	44392	COVER, ELECTRICAL JUNCTION BOX (CURRENT - FITS ITEM 1a)
2b	1	42475	COVER, ELECTRICAL JUNCTION BOX (ORIGINAL DESIGN - FITS ITEM 1b)
3	2	4111A8815S	SCREW, HEX HD #10-32 X 1/2"
4a	2	44390	TERMINAL BLOCK, 3-POLE (CURRENT)
4b	1	39258	TERMINAL BLOCK (ORIGINAL DESIGN)
5	1	31589	GROUND LUG
6	1	33983	HIGH LIMIT CONTROL MODULE, 240V
7	1	30693	RESET BUTTON, HIGH LIMIT 240V
8	4	41835	CIRCUIT BREAKER, 15A
9	2	42501	CIRCUIT BREAKER, 2A

ITEM	QTY.	P/N	DESCRIPTION
10	1	28041-0011	CONTACTOR
11	2	39530	AIR SWITCH
12	A/R	22450-0297	TUBING, SILICONE BULK 1/4"/6.4mm O.D.
13	A/R	15125-0002	TUBING, ALUMINUM BULK 1/4"/6.4mm O.D.
14	2	28021-0047	SAFETY SWITCH, BLOWER MOTOR SHROUD
15a	2	44469	ASSEMBLY, START CAPACITOR (BLACK) - INCLUDES BRACKET AND END CAP
15b	2	27170-0269	START CAPACITOR (BLACK) - WITHOUT BRACKET OR END CAP
16	2	27170-0270	CAPACITOR, RUN (SILVER)
17	2	44465	INSULATOR CAP, RUN CAPACITOR
18	4	22450-0259	HOSE CLAMP
19	2	41668	MOUNTING BRACKET, SIDE COMPARTMENT COMPONENTS
20	2	43102	MOUNTING BRACKET, BLOWER MOTOR SHROUD, TOP
21	2	43126	MOUNTING BRACKET, BLOWER MOTOR SHROUD, BOTTOM

↳

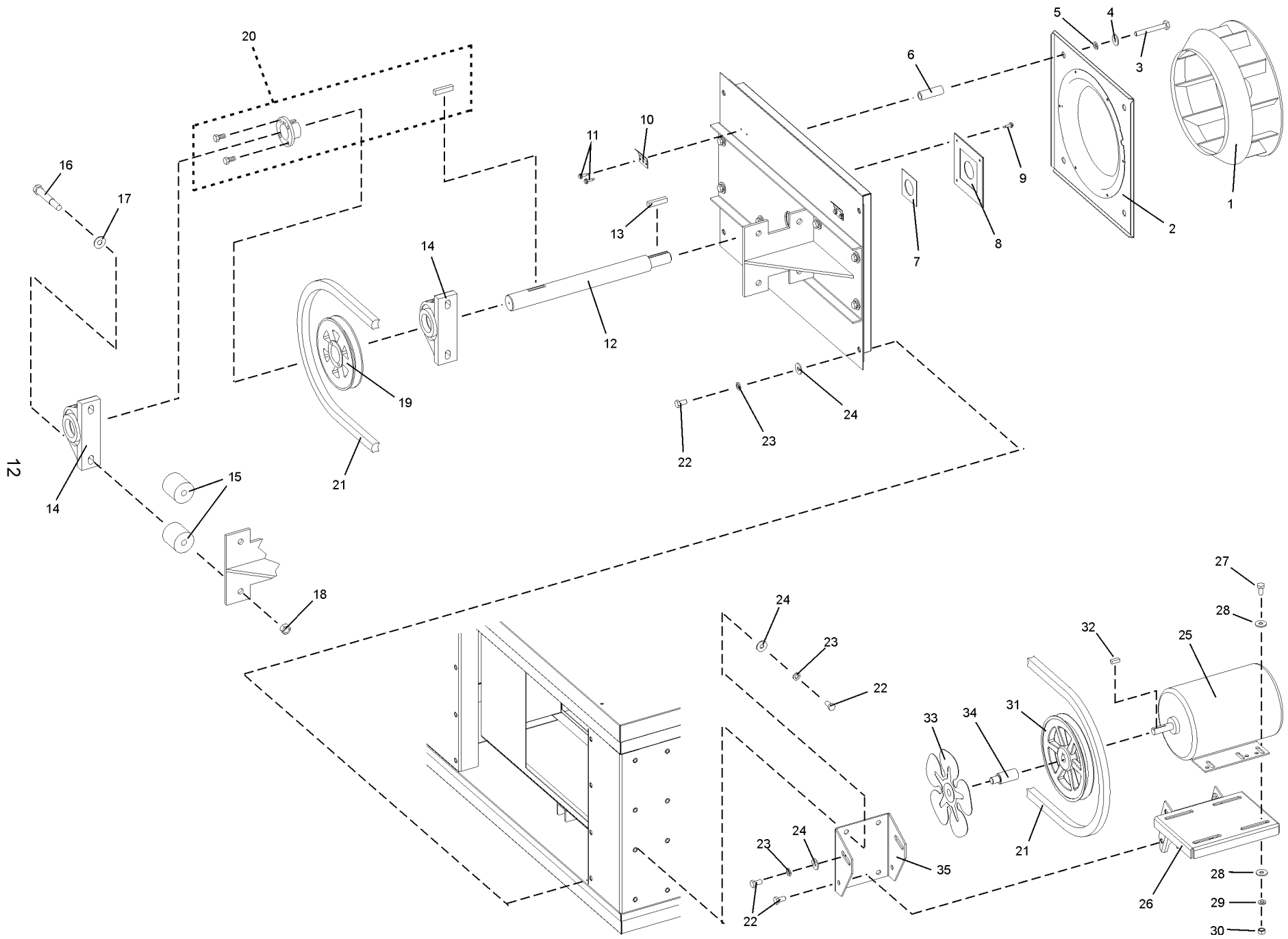

VII. BLOWER ASSEMBLIES AND BLOWER MOTORS

NOTE: The quantities shown below are for a single blower assembly.

ITEM	QTY.	P/N	DESCRIPTION
1a	1	22521-0005	BLOWER WHEEL - CCW, DRIVE END
1b	1	22521-0006	BLOWER WHEEL - CW, IDLER END
2	1	37210-0124	PLATE, INLET RING
3	4	21211-0001	SCREW, CAP HEX HD 3/8"-16 X 3"
4	4	21416-0001	FLAT WASHER, 3/8"
5	4	21422-0001	LOCKWASHER, SPLIT, 3/8"
6	4	35210-0576	SPACER
7	1	35210-0541	SHAFT SEAL, TEFLON
8	1	37210-0101	PLATE, SHAFT SEAL INNER
9	4	21292-0001	SCREW, HEX WSHR HD #10-16 X 3/4"
10	2	35000-1622	HANGER, REAR SHROUD
11	4	21292-0001	SCREW, HEX WSHR HD #10-16 X 3/4"
12	1	41899	SHAFT, BLOWER
13	1	35210-0286	KEY, BLOWER WHEEL
14	2	22072-0017	BEARING
15	4	39411	SPACER, BEARING
16	4	21322-0014	SCREW, CAP HEX HD 1/2"-13 X 3-1/2"
17	4	A6235	FLAT WASHER, 7/16"
18	4	21121-0013	HEX NUT, 1/2"-13

13

ITEM	QTY.	P/N	DESCRIPTION
19	1	39587	PULLEY, BK70
20	1	22031-0018	BUSHING, SPLIT, 1-7/16" I.D. (INC. KEY AND 2 BOLTS)
21	1	42662	BELT, B62
22	12	1513D8805	SCREW, CAP HEX HD 3/8"-16 X 3/4"
23	10	21422-0001	LOCKWASHER, SPLIT 3/8"
24	10	21416-0001	FLAT WASHER, 3/8"
25	1	27381-0069	MOTOR, BLOWER, 1 HP
26	1	41666	BRACKET, MOTOR MOUNTING
27	4	A3896	SCREW, CAP HEX HD 5/16"-18 X 1"
28	8	3023A8807	FLAT WASHER, 5/16"
29	4	21421-0004	LOCKWASHER, SPLIT 5/16"
30	4	B10012	HEX NUT, 5/16"-18
31a	1	39587	PULLEY, BK70
31b	1	39586	PULLEY, BK80
32	1	220026	KEY, PULLEY 3/16" x 3/16" X 3/4" (5x5x19mm)
33	1	43024	EXTENDER, FAN
34a	1	27399-0008	FAN BLADE, CW
34b	1	27399-0009	FAN BLADE, CCW
35	1	41667	BRACKET, MOTOR SUPPORT

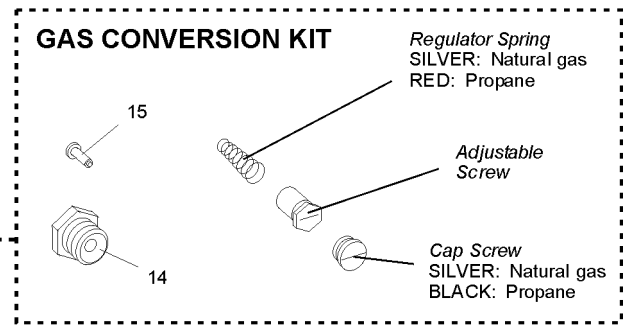
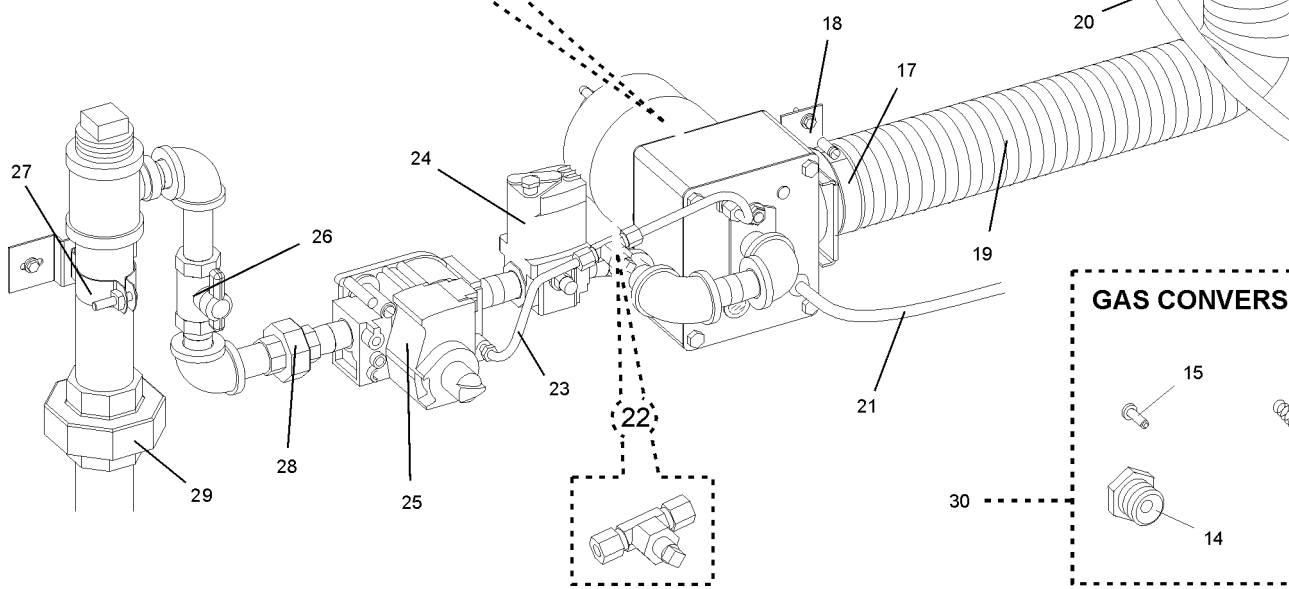
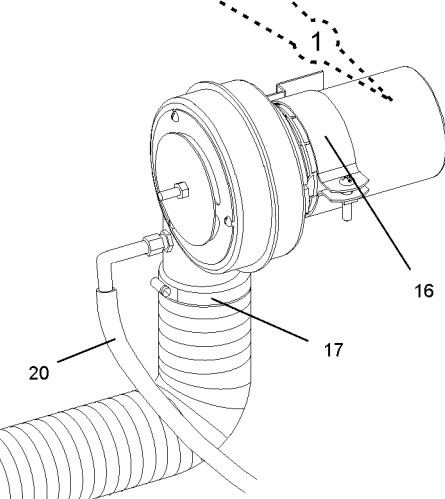
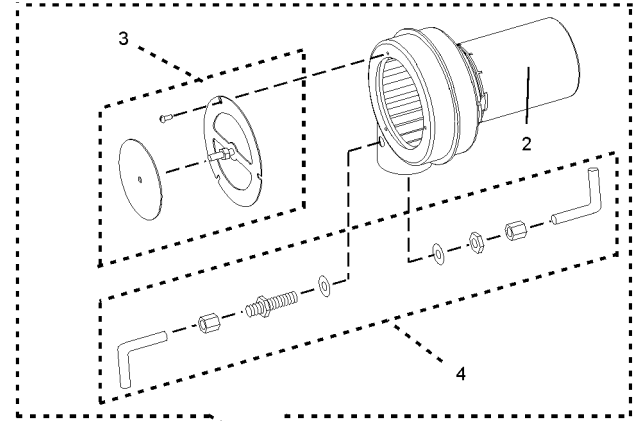
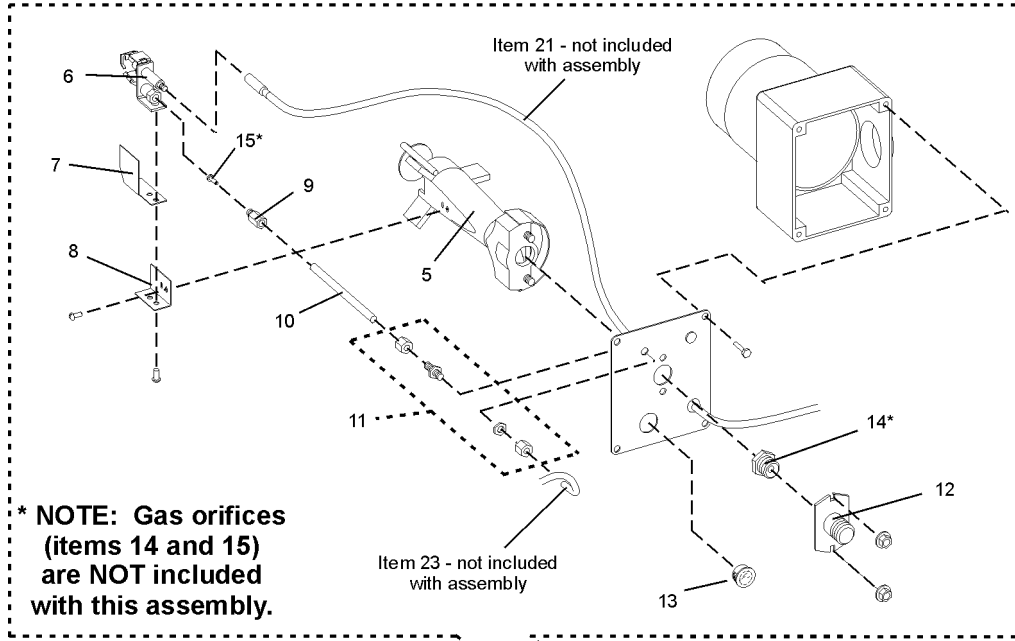

VIII. GAS BURNER SYSTEM

ITEM	QTY.	P/N	DESCRIPTION
--	1	38126	ASSEMBLY, BURNER <i>(INCLUDES ITEMS 1-13)</i>
1	1	38811	ASSEMBLY, BURNER BLOWER AND MOTOR <i>(INCLUDES ITEMS 2-4)</i>
2	1	--	BLOWER AND MOTOR
3	1	42810-0087	KIT, EXTERNAL AIR SHUTTER
4	1	42400-0640	KIT, PILOT TUBE
5	1	38127	VENTURI
6	1	42810-0117	PILOT WITH IGNITOR
7	1	27170-0204	PILOT SHIELD
8	1	27170-0264	BRACKET, PILOT MOUNTING
9	1	38284	FITTING, PILOT TUBING
10	A/R	15125-0002	TUBING, ALUMINUM, 1/4"/6.4mm O.D.
11	1	36920	FITTING, BULKHEAD
12	1	38279	ORIFICE HOLDER/INLET CONNECTOR
13	1	38280	WINDOW PLUG
14a	1	43059	MAIN ORIFICE, PS555 NATURAL GAS, 0.228" (5.79mm)
14b	1	43060	MAIN ORIFICE, PS555 PROPANE, 0.141" (3.58mm)
15a	1	22174-0011	PILOT ORIFICE, NATURAL GAS, 0.028" (0.71mm)
15b	1	22174-0010	PILOT ORIFICE, PROPANE, 0.018" (0.46mm)
16	1	39582	BRACKET, MOTOR MOUNTING

15

ITEM	QTY.	P/N	DESCRIPTION
17	2	22450-0259	HOSE CLAMP
18	1	37210-0026	BRACKET, HOSE AND BURNER MOUNTING
19	1	22450-0255	AIR DUCT, FLEXIBLE
20	A/R	38290	TUBING, SILICONE RUBBER, 1/4"/6.4mm DIA.
21	1	27159-0019	IGNITION/SENSOR WIRE
22	1	30185	KIT, PILOT TEE 1/4"/6.4mm
23	A/R	15125-0002	TUBING, ALUMINUM, 1/4"/6.4mm O.D.
24	1	41647	VALVE, MODULATING GAS, 1/2"
25	1	42810-0121	KIT, COMBINATION GAS VALVE (SAFETY REGULATOR), 1/2"
26	1	23115-0009	VALVE, SHUTOFF 1/2"
27	1	41649	BRACKET, PIPE MOUNTING 1-1/4"
28	1	23051-0003	UNION, PIPE 1/2"
29	1	23051-0012	UNION, PIPE 1-1/4"
30a	--	43061	KIT, PS555 GAS CONVERSION, PROPANE TO NATURAL GAS OPERATION <i>(INCLUDES ITEMS 15a, 16a, AND ALL PARTS AND INSTRUCTIONS FOR CONVERSION)</i>
30b	--	43062	KIT, PS555 GAS CONVERSION, NATURAL GAS TO PROPANE OPERATION <i>(INCLUDES ITEMS 15b, 16b, AND ALL PARTS AND INSTRUCTIONS FOR CONVERSION)</i>

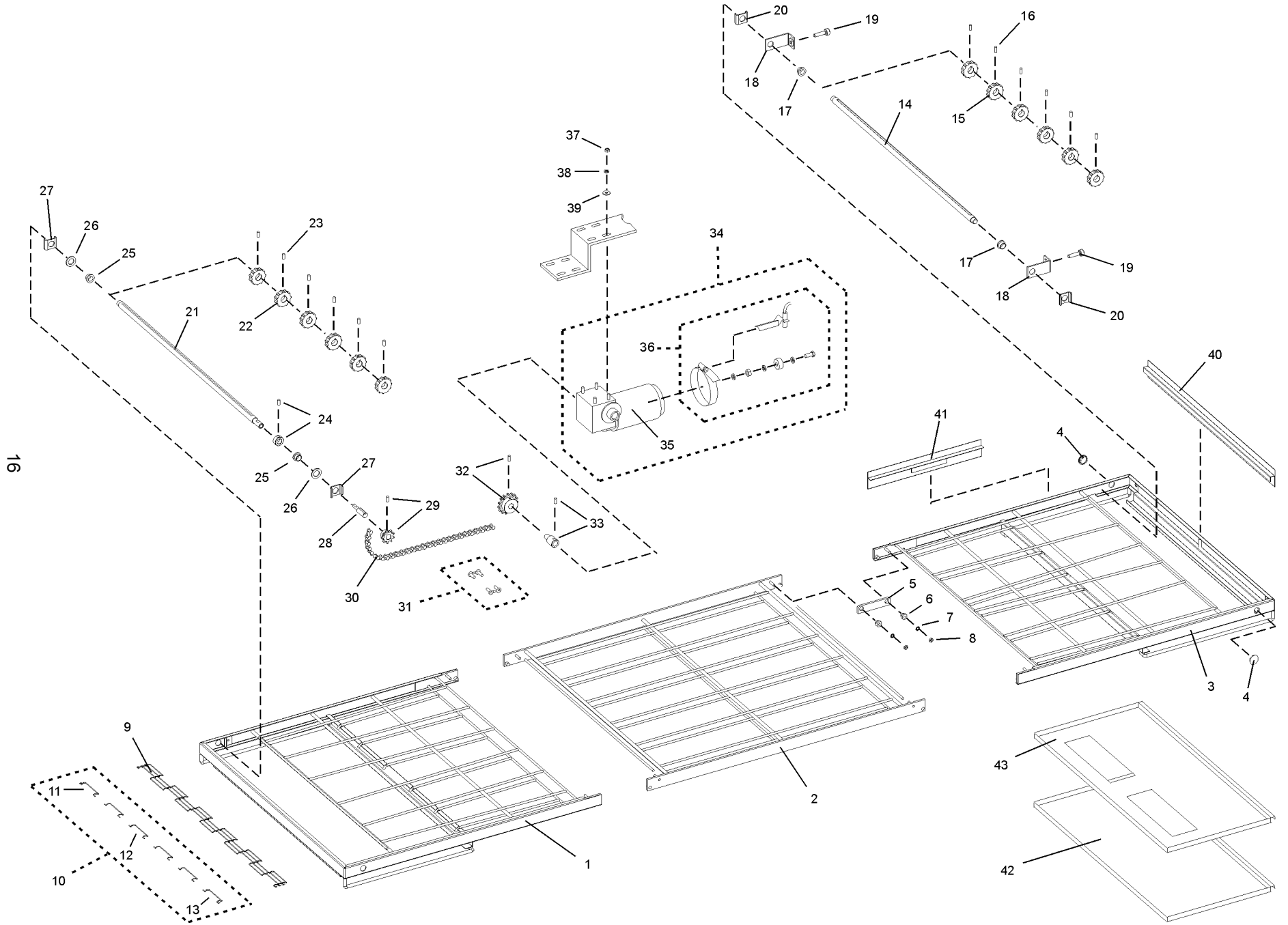

IX. CONVEYOR - SINGLE-BELT OVENS

ITEM	QTY.	P/N	DESCRIPTION
1	1	42518	WELDMENT, CONVEYOR DRIVE FRAME
2	1	37210-0046	WELDMENT, CONVEYOR CENTER FRAME
3	1	42518	WELDMENT, CONVEYOR IDLER FRAME
4	2	27413-0002	PLUG, 3/4" (19mm) DIA.
5	4	35210-0429	PIVOT PLATE
6	8	35210-0491	BUSHING, CONVEYOR ADJUSTMENT
7	8	F716A8805	WASHER, EXTERNAL TOOTH 1/4"
8	8	21176-0001	LOCKNUT, HEX 1/4"-20
9a	1	22450-0002	CONVEYOR BELT, COMPLETE, 32"W x 174"L (0.81 X 4.42m)
9b	--	33900-0032	CONVEYOR BELT, 32"W x 12"L (0.81 X 0.30m)
10	1	42400-0089	MASTER LINKS KIT, 32" (0.81m) BELT (INC. ITEMS 11-13)
11	1	--	MASTER LINK, LEFT
12	4	--	MASTER LINK, CENTER
13	1	--	MASTER LINK, RIGHT
14	1	35000-1011	SHAFT, IDLER
15	6	22229-0003	SPROCKET, CONVEYOR BELT (INC. ITEM 16)
16	6	21276-0039	SET SCREW, CONVEYOR BELT SPROCKET, 1/4"-28 X 3/8" (INC. WITH ITEM 15)
17	2	22034-0003	BUSHING, BRONZE 3/4" O.D. X 5/8" I.D.
18	2	37000-0413	BRACKET, IDLER SHAFT ADJUSTMENT
19	2	35000-1008	SCREW, CONVEYOR TENSION ADJUSTMENT
20	2	35900-0020	BRACKET, SHAFT SUPPORT
21	1	35000-1012	SHAFT, DRIVE
22	6	22229-0003	SPROCKET, CONVEYOR BELT (INC. ITEM 23)
23	6	21276-0039	SET SCREW, CONVEYOR BELT SPROCKET, 1/4"-28 X 3/8" (INC. WITH ITEM 22)
24	1	22011-0013	COLLAR, SHAFT, WITH SET SCREW

ITEM	QTY.	P/N	DESCRIPTION
25	2	22034-0003	BUSHING, BRONZE 3/4" O.D. X 5/8" I.D.
26	2	35000-1080	SPACER, NYLON 1-1/4" O.D. X 3/4" I.D.
27	2	35900-0020	BRACKET, SHAFT SUPPORT
28	1	35000-1013	ADAPTER, DRIVE SHAFT
29	1	22152-0017	SPROCKET, DRIVE SHAFT, 5/8" BORE, 9T, WITH SET SCREW
30	1	42400-0164	ASSEMBLY, ROLLER CHAIN COMPLETE (62 LINKS)
31	1	22273-0001	MASTER LINK, ROLLER CHAIN
32	1	22152-0018	SPROCKET, DRIVE MOTOR, 5/8" BORE, 15T, WITH SET SCREW
33	1	35210-0640	ADAPTER, DRIVE MOTOR, WITH SET SCREW
34	1	42400-0414	ASSEMBLY, DRIVE MOTOR AND PICKUP (INC. ITEMS 35-36)
35	1	27384-0008	DRIVE MOTOR, 1/8 HP, 1400:1
--	2	22450-0052	BRUSHES, DRIVE MOTOR
36	1	27170-0263	ASSEMBLY, PICKUP, DRIVE MOTOR
37	4	21411-0003	FLAT WASHER, 1/4"
38	4	21426-0002	LOCKWASHER, 1/4"
39	4	21126-0009	HEX NUT, 1/4"-20
40	1	35000-1103	END STOP, CONVEYOR
41	1	35900-0148	REAR STOP, CONVEYOR
42a	2	30003	CRUMB PAN, ALUMINIZED (WITHOUT OPENINGS - FOR LOWER OVEN CAVITY ONLY)
42b	2	35210-0262	CRUMB PAN, STAINLESS STEEL (WITHOUT OPENINGS - FOR LOWER OVEN CAVITIES ONLY)
43a	2	30004	CRUMB PAN, ALUMINIZED (WITH OPENINGS - FOR ALL UPPER OVEN CAVITIES)
43b	2	35210-0179	CRUMB PAN, STAINLESS STEEL (WITH OPENINGS - FOR ALL UPPER OVEN CAVITIES)

17

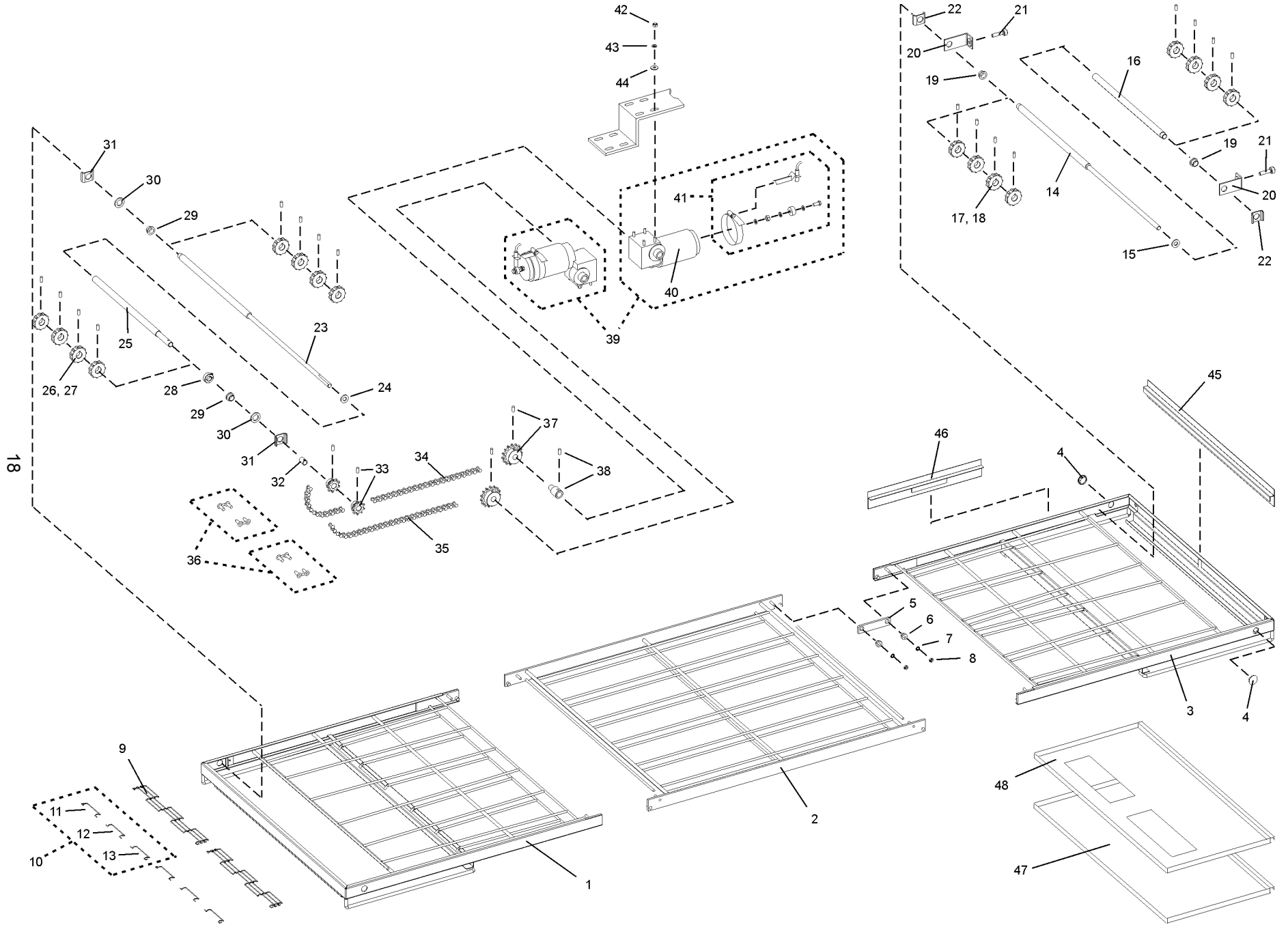

X. CONVEYOR - SPLIT-BELT OVENS

ITEM QTY.	P/N	DESCRIPTION
1 1	42518	WELDMENT, CONVEYOR DRIVE FRAME
2 1	37210-0046	WELDMENT, CONVEYOR CENTER FRAME
3 1	42518	WELDMENT, CONVEYOR IDLER FRAME
4 2	27413-0002	PLUG, 3/4" (19mm) DIA.
5 4	35210-0429	PIVOT PLATE
6 8	35210-0491	BUSHING, CONVEYOR ADJUSTMENT
7 8	F716A8805	WASHER, EXTERNAL TOOTH 1/4"
8 8	21176-0001	LOCKNUT, HEX 1/4"-20
9a 2	22450-0094	CONVEYOR BELT, COMPLETE, 15"W x 174"L (0.38 X 4.42m)
9b --	33900-0037	CONVEYOR BELT, 15"W x 12"L (0.38 X 0.30m)
10 2	NOT AVAILABLE	MASTER LINKS KIT, 15" (0.38m) BELT (INC. ITEMS 11-13)
11 1	--	MASTER LINK, LEFT
12 1	--	MASTER LINK, CENTER
13 1	--	MASTER LINK, RIGHT
14 1	42400-0354	SHAFT, IDLER, REAR
15 1	21415-0001	FLAT WASHER, BRONZE, 1" O.D. X 1/2" I.D.
16 1	35000-1535	SHAFT, IDLER, FRONT
17 8	22229-0003	SPROCKET, CONVEYOR BELT (INC. ITEM 18)
18 8	21276-0039	SET SCREW, CONVEYOR BELT SPROCKET, 1/4"-28 X 3/8" (INC. WITH ITEM 17)
19 2	22034-0003	BUSHING, BRONZE 3/4" O.D. X 5/8" I.D.
20 2	37000-0413	BRACKET, IDLER SHAFT ADJUSTMENT
21 2	35000-1008	SCREW, CONVEYOR TENSION ADJUSTMENT
22 2	35900-0020	BRACKET, SHAFT SUPPORT
23 1	42400-0355	SHAFT, DRIVE, REAR
24 1	21415-0001	FLAT WASHER, BRONZE, 1" O.D. X 1/2" I.D.
25 1	35000-1536	SHAFT, DRIVE, FRONT
26 8	22229-0003	SPROCKET, CONVEYOR BELT (INC. ITEM 27)
27 8	21276-0039	SET SCREW, CONVEYOR BELT SPROCKET, 1/4"-28 X 3/8" (INC. WITH ITEM 26)

ITEM QTY.	P/N	DESCRIPTION
28 1	22011-0014	COLLAR, SPLIT LOCKING
29 2	22034-0003	BUSHING, BRONZE 3/4" O.D. X 5/8" I.D.
30 2	35000-1080	SPACER, NYLON 1-1/4" O.D. X 3/4" I.D.
31 2	35900-0020	BRACKET, SHAFT SUPPORT
32 1	35000-1537	BUSHING, SPLIT BELT DRIVE SPROCKET
33 2	22152-0017	SPROCKET, DRIVE SHAFT, 5/8" BORE, 9T, WITH SET SCREW
34 1	42400-0164	ASSEMBLY, ROLLER CHAIN COMPLETE (62 LINKS)
35 1	42410-0128	ASSEMBLY, ROLLER CHAIN COMPLETE (48 LINKS)
36 2	22273-0001	MASTER LINK, ROLLER CHAIN
37 2	22152-0018	SPROCKET, DRIVE MOTOR, 5/8" BORE, 15T, WITH SET SCREW
38 1	35210-0640	ADAPTER, DRIVE MOTOR, WITH SET SCREW
39 2	42400-0414	ASSEMBLY, DRIVE MOTOR AND PICKUP (INC. ITEMS 40-41)
40 1	27384-0008	DRIVE MOTOR, 1/8 HP, 1400:1
-- 2	22450-0052	BRUSHES, DRIVE MOTOR
41 1	27170-0263	ASSEMBLY, PICKUP, DRIVE MOTOR
42 8	21411-0003	FLAT WASHER, 1/4"
43 8	21426-0002	LOCKWASHER, 1/4"
44 8	21126-0009	HEX NUT, 1/4"-20
45 1	35000-1103	END STOP, CONVEYOR
46 1	35900-0148	REAR STOP, CONVEYOR
47a 2	30003	CRUMB PAN, ALUMINIZED (WITHOUT OPENINGS - FOR LOWER OVEN CAVITY ONLY)
47b 2	35210-0262	CRUMB PAN, STAINLESS STEEL (WITHOUT OPENINGS - FOR LOWER OVEN CAVITIES ONLY)
48a 2	30004	CRUMB PAN, ALUMINIZED (WITH OPENINGS - FOR ALL UPPER OVEN CAVITIES)
48b 2	35210-0179	CRUMB PAN, STAINLESS STEEL (WITH OPENINGS - FOR ALL UPPER OVEN CAVITIES)

19

WARNING

Improper installation, adjustment, alteration, service or maintenance can cause property damage, injury or death. Read the installation, operating and maintenance instructions thoroughly before installing or servicing this equipment.

NOTICE

During the warranty period, ALL parts replacement and servicing should be performed by your Middleby Marshall Authorized Service Agent. Service that is performed by parties other than your Middleby Marshall Authorized Service Agent may void your warranty.

NOTICE

Using any parts other than genuine Middleby Marshall factory manufactured parts relieves the manufacturer of all warranty and liability.

NOTICE

Middleby Marshall reserves the right to change specifications at any time.

PS555
USA & Std. Export

Middleby Cooking Systems Group • 1400 Toastmaster Drive • Elgin, IL 60120 • USA • (847)741-3300 • FAX (847)741-4406

24-Hour Service Hotline: 1-(800)-238-8444

www.middleby.com

