

# **Holman**<sup>®</sup> **MINIVEYOR** **MULTI-PURPOSE OVEN**

MODEL  
210HX, 214HX Series

## **Installation and Operation Instructions**

2M-HG0104 Rev.J 1/18/2012

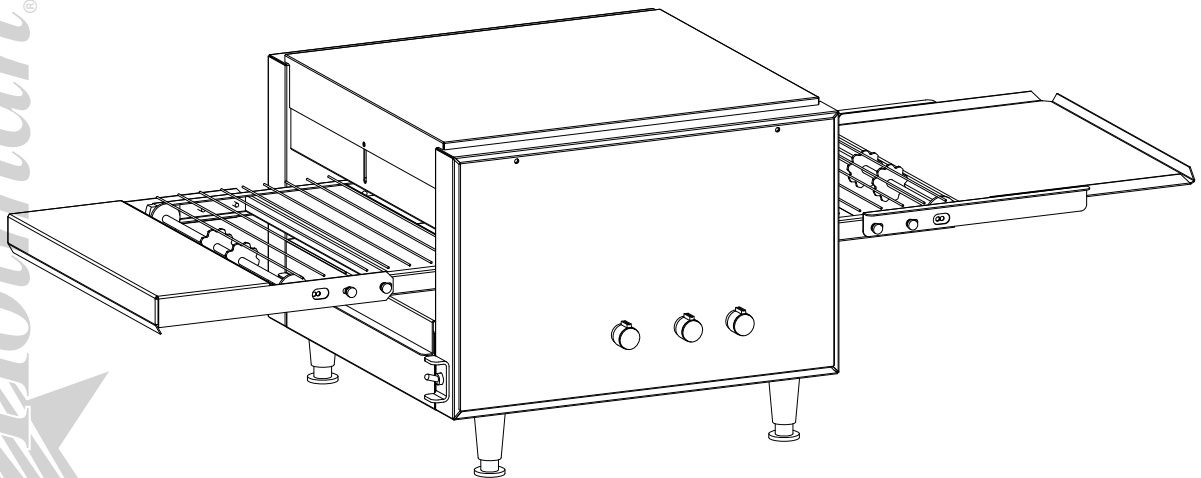

214HX

ALL MODELS



210HX-V67 & V68  
214HXA-V68



## SAFETY SYMBOL



These symbols are intended to alert the user to the presence of important operating and maintenance instructions in the manual accompanying the appliance.

---

## RETAIN THIS MANUAL FOR FUTURE REFERENCE NOTICE

Using any part other than genuine Star factory supplied parts relieves the manufacturer of all liability.

Star reserves the right to change specifications and product design without notice. Such revisions do not entitle the buyer to corresponding changes, improvements, additions or replacements for previously purchased equipment.

Due to periodic changes in designs, methods, procedures, policies and regulations, the specifications contained in this sheet are subject to change without notice. While Star International Holdings Inc., Company exercises good faith efforts to provide information that is accurate, we are not responsible for errors or omissions in information provided or conclusions reached as a result of using the specifications. By using the information provided, the user assumes all risks in connection with such use.

## MAINTENANCE AND REPAIRS

Contact your local authorized service agent for service or required maintenance.

Please record the model number, serial number, voltage and purchase date in the area below and have it ready when you call to ensure a faster service.

Model No. \_\_\_\_\_  
Serial No. \_\_\_\_\_  
Voltage \_\_\_\_\_  
Purchase Date \_\_\_\_\_

### Authorized Service Agent Listing

Reference the listing provided with the unit

or

for an updated listing go to:

**Website:** [www.star-mfg.com](http://www.star-mfg.com)  
**E-mail** [Service@star-mfg.com](mailto:Service@star-mfg.com)

### Service Help Desk

**Business Hours:** 8:00 am to 4:30 p.m. Central Standard Time

**Telephone:** (314) 678-6303

**Fax:** (314) 781-2714

**E-mail** [Parts@star-mfg.com](mailto:Parts@star-mfg.com)  
[Service@star-mfg.com](mailto:Service@star-mfg.com)  
[Warranty@star-mfg.com](mailto:Warranty@star-mfg.com)

**Website:** [www.star-mfg.com](http://www.star-mfg.com)

**Mailing Address:** Star International Holdings Inc., Company  
10 Sunnen Drive  
St. Louis, MO 63143  
U.S.A

## SPECIFICATIONS

---

### **210HX-120V - 60Hz**

Rating/Connection: 1,700 Watts  
NEMA Plug: 5-15P, CUL 5-20P  
Electrical Supply: Separate service per oven - 14.2 Amp, 120 VAC, 60 Hz  
Approximate Weight (210HX Oven with Legs): Installed - 61.5 Lbs (28 kg), Shipping - 39.5 Lbs (18 kg)  
Dimensions: Width: 46 11/16" (118.6 cm) - Oven with Shelves  
Depth: 15 7/16" (39.2 cm)  
Height: 14" (35.5 cm) - Single Oven with Legs

---

### **210HX-208V - 60Hz**

Rating/Connection: 2,800 Watts  
NEMA Plug: 6-20P  
Electrical Supply: Separate service per oven - 13.5 Amp, 208 VAC, 60 Hz  
Approximate Weight (210HX Oven with Legs): Installed - 61.5 Lbs (28 kg), Shipping - 39.5 Lbs (18 kg)  
Dimensions: Width: 46 11/16" (118.6 cm) - Oven with Shelves  
Depth: 15 7/16" (39.2 cm)  
Height: 14" (35.5 cm) - Single Oven with Legs

---

### **210HX-220V - 50 Hz**

Rating/Connection: 2,800 Watts  
NEMA Plug: CE-16A Cord  
Electrical Supply: Separate service per oven - 12.7 Amp, 220 VAC, 50 Hz  
Approximate Weight (210HX Oven with Legs): Installed - 61.5 Lbs (28 kg), Shipping - 39.5 Lbs (18 kg)  
Dimensions: Width: 46 11/16" (118.6 cm) - Oven with Shelves  
Depth: 15 7/16" (39.2 cm)  
Height: 14" (35.5 cm) - Single Oven with Legs

---

### **210HX-240V - 60 & 50 Hz**

Rating/Connection: 2,800 Watts  
NEMA Plug: 6-20P CE-16A Cord  
Electrical Supply: Separate service per oven - 11.7 Amp, 240 VAC, 60 Hz & 50 Hz  
Approximate Weight (210HX Oven with Legs): Installed - 61.5 Lbs (28 kg), Shipping - 39.5 Lbs (18 kg)  
Dimensions: Width: 46 11/16" (118.6 cm) - Oven with Shelves  
Depth: 15 7/16" (39.2 cm)  
Height: 14" (35.5 cm) - Single Oven with Legs

---

### **214HX-208V - 60 Hz**

Rating/Connection: 4,000 Watts  
NEMA Plug: 6-30P  
Electrical Supply: Separate service per oven - 19.3 Amp, 208 VAC, 60 Hz  
Approximate Weight (214HX Oven with Legs): Installed - 77.5 Lbs (31 kg), Shipping - 44.5 Lbs (20 kg)  
Dimensions: Width: 46 11/16" (118.6 cm) - Oven with Shelves, 48 3/16" (122.4 cm) 214HXETB  
Depth: 19 7/16" (39.2 cm)  
Height: 14" (35.5 cm) - Single Oven with Legs

---

### **214HX-220V - 50 Hz**

Rating/Connection: 4,000 Watts  
NEMA Plug: N/A  
Electrical Supply: Separate service per oven - 18.2 Amp, 220 VAC, 50 Hz  
Approximate Weight (214HX Oven with Legs): Installed - 77.5 Lbs (31 kg), Shipping - 44.5 Lbs (20 kg)  
Dimensions: Width: 46 11/16" (118.6 cm) - Oven with Shelves  
Depth: 19 7/16" (39.2 cm)  
Height: 14" (35.5 cm) - Single Oven with Legs

---

### **214HX-240V - 60 & 50 Hz**

Rating/Connection: 4,000 Watts  
NEMA Plug: 6-30P CE-16A Cord  
Electrical Supply: Separate service per oven - 16.7 Amp, 240 VAC, 60 Hz & 50 Hz  
Approximate Weight (214HX Oven with Legs): Installed - 77.5 Lbs (31 kg), Shipping - 44.5 Lbs (20 kg)  
Dimensions: Width: 46 11/16" (118.6 cm) - Oven with Shelves, 48 3/16" (122.4 cm) 214HXETB  
Depth: 19 7/16" (39.2 cm)  
Height: 14" (35.5 cm) - Single Oven with Legs

---

Check with factory for CE approved models.



## GENERAL INSTALLATION DATA

This equipment is designed and sold for commercial use only by personnel trained and experienced in its operation and is not sold for consumer use in and around the home nor for use directly by the general public in food service locations.

Before using your new equipment, read and understand all the instructions & labels associated with the unit prior to putting it into operation. Make sure all people associated with its use understand the units operation & safety before they use the unit.

All shipping containers should be checked for freight damage both visible and concealed. This unit has been tested and carefully packaged to insure delivery of your unit in perfect condition. If equipment is received in damaged condition, either apparent or concealed, a claim must be made with the delivering carrier.

Concealed damage or loss - if damage or loss is not apparent until after equipment is unpacked, a request for inspection of concealed damage must be made with carrier within 15 days. Be certain to retain all contents plus external and internal packaging materials for inspection. The carrier will make an inspection and will supply necessary claim forms.

## INSPECTION & ASSEMBLY

### UNCRATING AND INSPECTING

Unpack the unit and components from the shipping container. Remove all visible packing material and those from inside the cooking chamber. If damage is discovered, file a claim immediately with the carrier that handled the shipment. Do not operate the unit if it was damaged during shipping.

The following should be included: Miniveyor Multi-Purpose Oven, Stainless Steel Load Up & Unload Trays, 4 Stainless Steel Legs.

### REMOVE ALL HEATING ELEMENT SHIPPING SUPPORTS PRIOR TO PLACING YOUR UNIT INTO OPERATION.

### ASSEMBLY AND INSTALLATION

The unit was shipped with certain assembly required, plug into a standard outlet specified for its voltage and amp draw. If improper electrical supply is determined, contact a qualified electrician prior to using the unit. Removal and replacement of the power cord and plug will void the warranty. For assistance, contact your local authorized service agent for service or required maintenance.

Attach the 4 legs by screwing them into the weld nuts located on the bottom of the unit. When complete, use two people to carefully turn the unit upright. Level unit by adjusting the feet (approximately 1/2" adjustment). Never operate unit without proper legs in place.

Before using the unit for the first time, wipe down the exterior with a damp cloth.

### CAUTION

Allow enough space around the oven for adequate ventilation. Do not operate the unit without the crumb tray properly positioned. Overheating and poor baking may occur. Read all labels on the unit and follow their instructions.

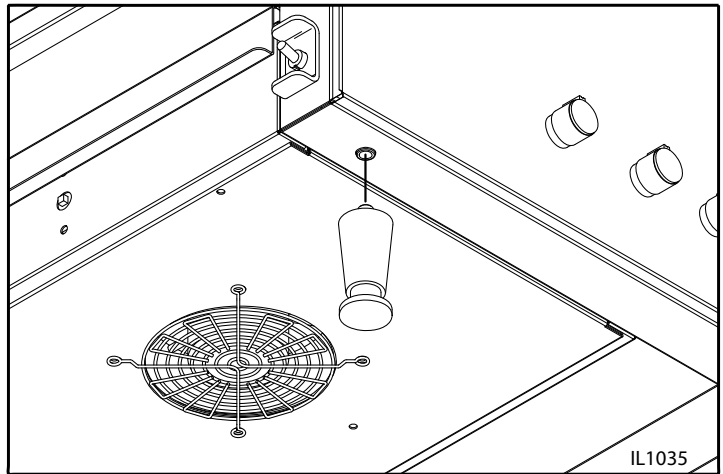

LEG INSTALLATION

## ASSEMBLY AND INSTALLATION continued

Install unit in its operating position allow sufficient space for operating personnel. Install the Crumb, Load and Unload Trays as shown, making sure the ends are at least 6" from any vertical combustible surfaces.

Have an electrician connect input power to the unit(s) in accordance with local electrical codes. A connection terminal block is inside the left side cavity for models not provided with a cord and plug set.

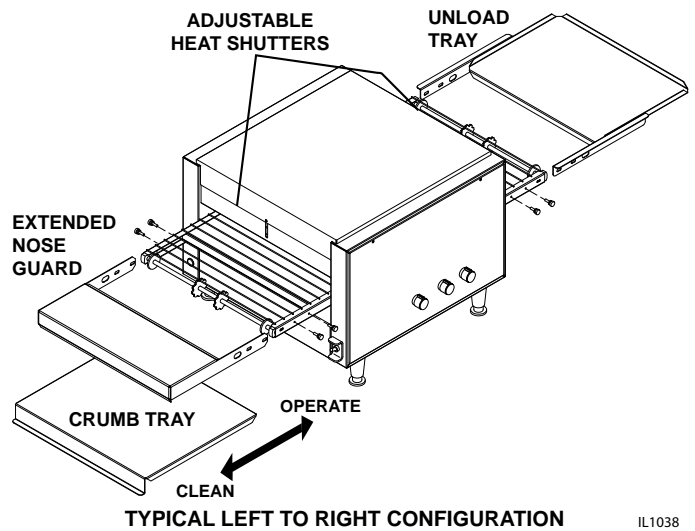

IL1038



## ELECTRICAL CONNECTION

Before making any electrical connection to this unit, check that the power supply is adequate for the voltage, amperage and requirements stated on the rating plate.

A wiring diagram is included herewith.

Disconnect the unit from the power source before installing or removing any parts.

Be absolutely sure that the ground connection for the receptacle is properly wired. Do not connect equipment to power without proper ground connections. Improper grounding may result in personal injury or fatality.



**DO NOT CUT OR REMOVE THIS PLUG OR GROUNDING PRONG FROM THE PLUG.**

**CONNECT/PLUG UNIT INTO DEDICATED A.C. LINE ONLY SPECIFIED ON THE DATA PLATE OF THE UNIT.**

## HEATING ELEMENTS

Inspect all heating elements in the unit for breakage. Every unit is properly tested prior to leaving the factory, but damage may have occurred during shipping. If a broken tube is found, do not apply power to the unit. If everything checks out, Turn on Main Power Switch, Turn both heat controls and conveyor belt speed control to the maximum setting and check all heater tubes and conveyor for proper operation.

## COOLING SYSTEM

After the unit is initially turned on, allow 5 to 8 minutes for the fan cooling system to come on. Once on, check the air intake area located under the unit and be sure that there is a sufficient flow of air into the control box. Keep area under the unit clean from obstructions that may result in restricted air flow to the control box. Restricting the air flow will cause the unit to run hotter than designed, causing the Hi-Limit to turn unit off. See the Oven Components section on page 7 for control box & Hi-Limit Reset locations.

## FINAL CHECK

If all heaters and conveyor systems are operating properly, switch the master on/off switch to the OFF position and allow unit to cool, the fan will continue to circulate air, cooling the unit until the internal temperatures have been decreased.

If a problem is discovered during any of these start-up procedures, immediately switch the master on/off switch to the **OFF** position and notify the Star Service Department at (314) 634-6303.

## STACKING OVENS

When stacking two Holman Miniveyor Ovens a stacking spacer with an external air duct **MUST** be used to prevent overheating of the control box of the top oven.

1. Place bottom unit in position where the oven will be located.
2. Place stacking spacer on top of the bottom oven with internal air duct facing up and towards the rear of the oven.
3. Mount external air duct on stacking spacer as shown below.  
External air duct must be installed for cooling system of top unit to function properly.
4. Screw set screws (Qty 4) into leg hole on the top oven.
5. Place top oven on stacking spacer. Set screws will set into cut out in top of stacking spacer to lock unit into position.



**NOTE:** Air intake of top unit must fit over the internal air duct of stacking spacer to allow airflow into the control box of the top oven.

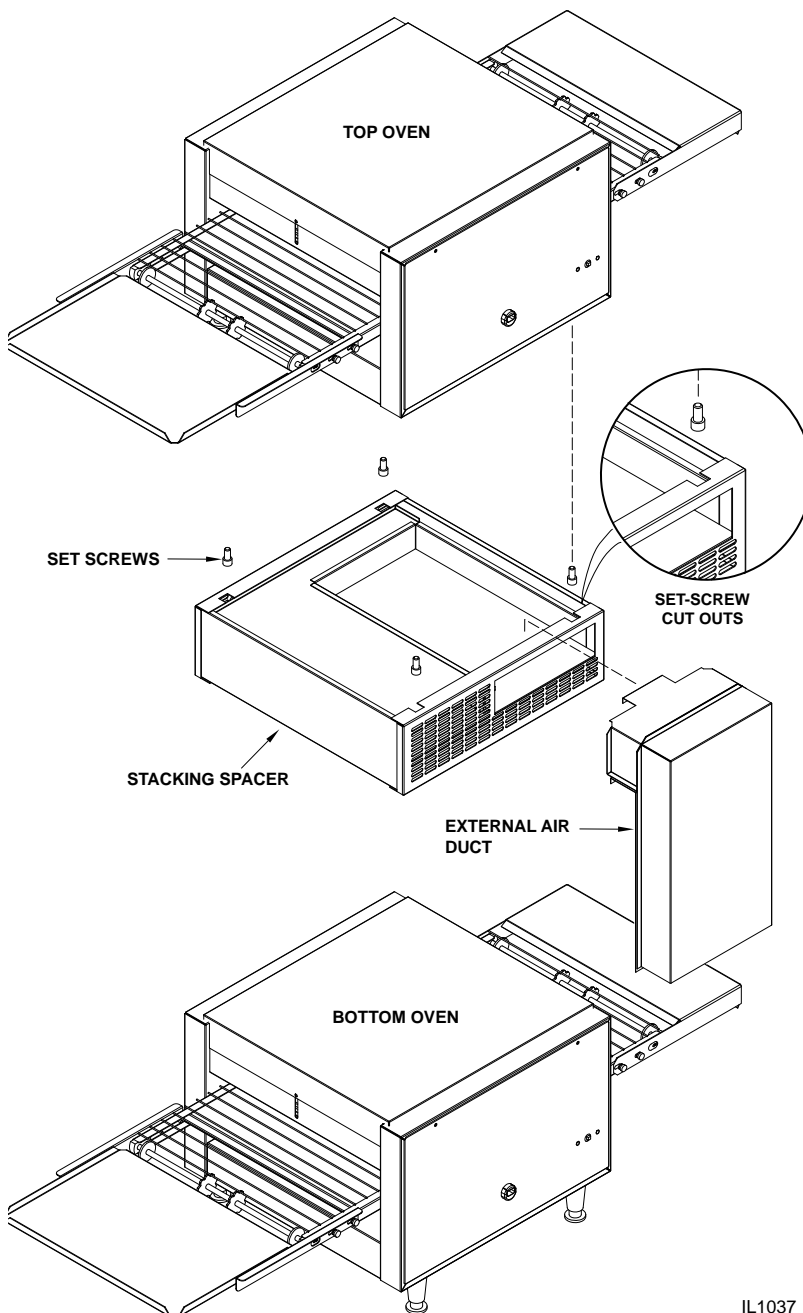

### TOP UNIT:

set screw, screws into leg holes, unit sits on top of spacer.

### STACKING SPACER:

(REQUIRED) Sits on top of bottom oven.

### EXTERNAL AIR DUCT:

Mounts onto spacer, pointing downward.

### BOTTOM UNIT:

Must be placed on a counter in a secure position.

## DAILY OPERATION

Baking in these units is a combination of heat and belt speed. Some foods may require more top heat or visa versa; other foods may require low top and bottom heat and slow belt speeds. Every product should, therefore, be tested using the separate top & bottom controls and the variable speed control to arrive at the correct balance of heat and belt speed. When changing heat and or belt speed setting allow approx. 5 minutes for the oven to stabilize itself at the new settings.

Check the power cord to insure that it is plugged into a proper outlet.

Always allow 10 to 15 minutes of preheat time before loading the unit with product. Failure to allow sufficient preheat time will result in unsatisfactory cooking until the cooking chamber reaches operating temperature. Even though the elements can reach there operating temperature very quickly, a certain amount of time is needed to allow the cooking chamber to reach its operating temperature.

- 1) Turn the master on/off switch to the ON position.
- 2) Set both the top and bottom heat controls to 500°F (260°C).
- 3) Turn conveyor speed control to the fastest setting.
- 4) Allow 15-20 minutes for initial warm up,  
(5 to 8 minutes to reach adjusted temperature, once unit is fully warmed up)
- 5) Once the unit is pre-heated, adjust the controls to the proper setting for the product you are preparing.



**CAUTION**

**CERTAIN SURFACES ARE EXTREMELY HOT DURING OPERATION AND CARE SHOULD BE TAKEN WHILE USING THIS UNIT.**

### OVEN COMPONENTS

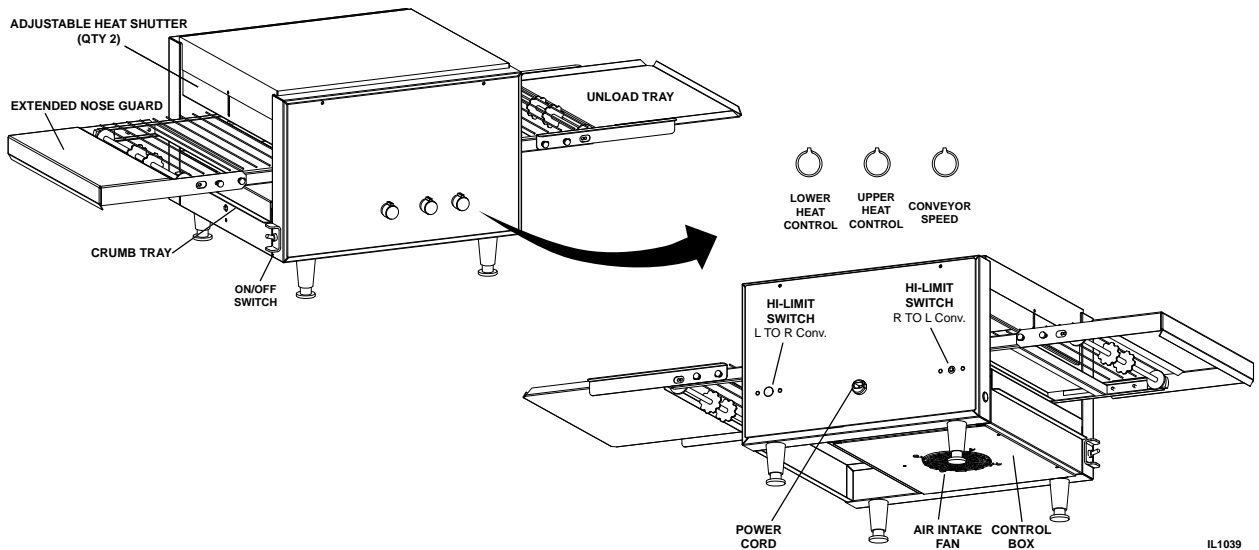

**CAUTION**

### OPERATING HINTS AND SAFETY

Disconnect power to the unit with the switch at the end of each day of operation.

Do not leave the unit in operation without an attendant.

Do not leave the unit at high temperature when not in use or during idle periods. This will cause food particles and grease film to carbonize. Turning the temperature setting down will save energy, It will take only a few minutes for the unit to regain operating temperature.

## CLEANING

Preventive maintenance for your Holman Oven consists of the following recommended cleaning procedures. To keep your oven in its top operating condition, these steps should be performed on a daily, weekly or as indicated.



### TURN UNIT OFF, DISCONNECT UNIT FROM POWER SUPPLY OR TURN POWER OFF AT WALL BREAKER, REMOVE PLUG FROM OUTLET.

#### DAILY

1. Turn main power switch to the OFF position. Disconnect unit from power source and allow unit to cool.
2. Using a mild detergent, wipe exterior surfaces, clean with a damp cloth.
  - a. For lightly soiled build-up, clean with a damp cloth.
  - b. For heavily soiled build-up, use a soft damp cloth and mild detergent.

**DO NOT use caustic cleaners.**

3. Remove the load & unload tray by lifting them out of position. Clean using mild detergent and warm water.
4. Remove each crumb tray by sliding each of them out from under the conveyor belt. Clean crumb trays by wiping with a damp cloth and mild detergent. **DO NOT use caustic cleaners.** Place trays back in place prior to putting unit back into operation.
5. Reconnect power.

#### WEEKLY

1. Turn main power saver switch to the OFF position. Disconnect unit from power source and allow to cool.
2. Perform daily cleaning procedures.
3. Using a damp cloth, wipe clean the fan guard located on the control box cover under the unit.

#### CLEAN CONVEYOR BELT

4. Reconnect power or turn power back on.
5. Switch the ON/OFF switch to the ON position, and turn Conveyor to its fastest setting.
6. With the Conveyor turned on and the crumb trays in place, take a wire grill brush or dry abrasive pad, clean the exposed surface of Conveyor Belt by passing the brush or pad, back and forth across the surface of the Conveyor Belt as the belt moves past. Continue until the entire belt is clean. Make sure the Crumb Tray is installed, this will minimize the amount of particles that fall into the oven.
7. When the Conveyor Belt is clean, take a damp cloth and wipe the conveyor, removing any loose particles on the belt surface.
8. Remove the Crumb Trays by sliding out from beneath the conveyor belt. Clean the Crumb Trays by wiping with a damp cloth and mild detergent. **DO NOT use caustic cleaners.**

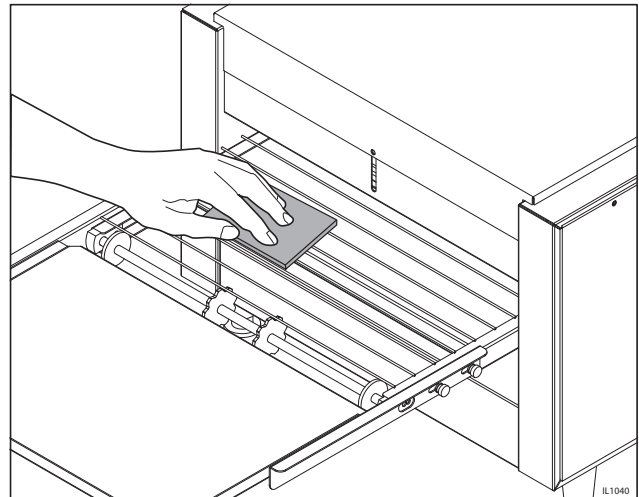

CLEANING CONVEYOR BELT



**DO NOT RUN CONVEYOR OVEN WITHOUT CRUMB TRAYS INSTALLED, OVERHEATING TO ELECTRICAL COMPONENTS AND PREMATURE FAILURE CAN OCCURE.**



**DO NOT IMMERSE OR LET THE UNIT STAND IN WATER.**

**DO NOT HOSE DOWN THE UNIT OR THE TABLE/COUNTER IF THE UNIT IS ON THE TABLE/COUNTER.**

**KEEP AWAY FROM RUNNING WATER.**



## CLEANING CONTINUED

### MONTHLY

1. Turn main power switch to the OFF position. Disconnect unit from its power source and allow to cool.
2. Perform daily & weekly cleaning procedures.

### REMOVAL & CLEANING CONVEYOR BELT

3. Heavily soiled conveyor surfaces, 214 models locate all 3 of the Master Links on the conveyor belt. Follow the step 1 in Fig 1, to remove all of the Master Links.

210 models have no master links, to remove, unhook each end of one link and bring the two ends together, and unthread. Once detached, re-hook onto itself so not to get damaged.

4. Now that the links have been unhooked, the conveyor can now be carefully removed from the oven. Standing at one end of the oven. Starting with the end on the bottom, roll the conveyor belt until it has been totally removed. Take careful notice being sure not to damage the heater tubes, and working it over the drive sprockets, (see Figure 2).
5. Clean conveyor belt in deep sink, caustic cleaners may be used. For a heavy soiled conveyor belt, soak over night in hot soapy water.

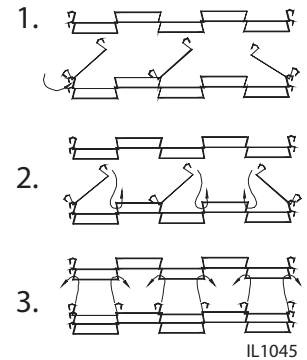

Fig 1. Master Links  
Removal & Installation

### NOTE: DO NOT ATTEMPT TO CLEAN THE HEATER TUBES.

6. Take this opportunity to clean and remove any loose materials inside the unit. Using a mild cleaner and damp cloth, carefully wipe the inside surfaces being sure NOT to clean the heater tubes.

**DAMAGE CAN OCCUR TO THE HEATER TUBES FROM IMPROPER CLEANING.**

### DO NOT SPRAY CLEANING SOLUTIONS INTO OVEN CAVITY.

7. Reinstall conveyor belt by first laying the belt along the bottom of the oven cavity making sure the hooks on the sides are facing the inside and the ends of the hooks will be pointing away from the direction of the belt so not to catch on any internal components once put back into operation. Also, being sure to properly align the belt over the Conveyor Drive Sprockets shown in Fig 2.

### NOTE: THE DIRECTION OF THE BELT.

8. Next, pull one end of the conveyor belt over the top of the sprockets, (being sure to line the links up properly with the sprockets) bringing the two ends together.
9. 214 models, Reinstall the previously removed master links as shown in steps 2 & 3 in Fig. 1.

210 Models, unhook the last link of the conveyor, farthest away from you, and rethread through the other end, and reconnect back onto itself.

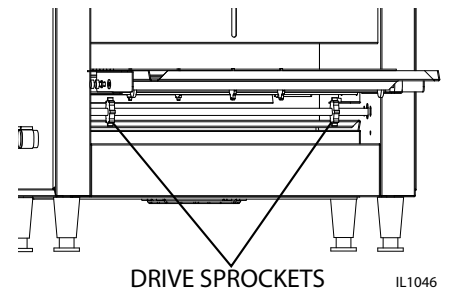

Fig 2. Conveyor Drive Sprockets

12. Examine the oven to assure proper installation, once satisfied, install crumb trays if you have not done so.  
**DO NOT OPERATE UNIT WITHOUT CRUMB TRAYS INSTALLED.**
13. Reconnect oven to power supply and check for proper operation.

**IF ASSISTANCE IS REQUIRED, CALL THE STAR SERVICE TEAM AT (314) 634-6303.**



**CAUTION**



**CAUTION**

## MAINTENANCE PROCEDURES

### A. REPLACING HEATER TUBES

- 1) **DISCONNECT POWER SOURCE.**
- 2) Remove both the left and right side panels, by removing the truss head screws. Pull the top of each panel out slightly and lift up.
- 3) Remove each heater tube wires which are requiring replacement from its terminal block connection. One Tube at a Time.
- 4) Remove heater tube retainer by removing retainer screws with washer.
- 5) Gently, pull defective heater tube out of unit.
- 6) Gently, put new heater tube into unit.
- 7) Replace heater tube retainers.
- 8) Reconnect the heater tube wires to the terminal block.
- 9) Install each side panel
- 10) Connect unit to power source and test unit for proper operation.

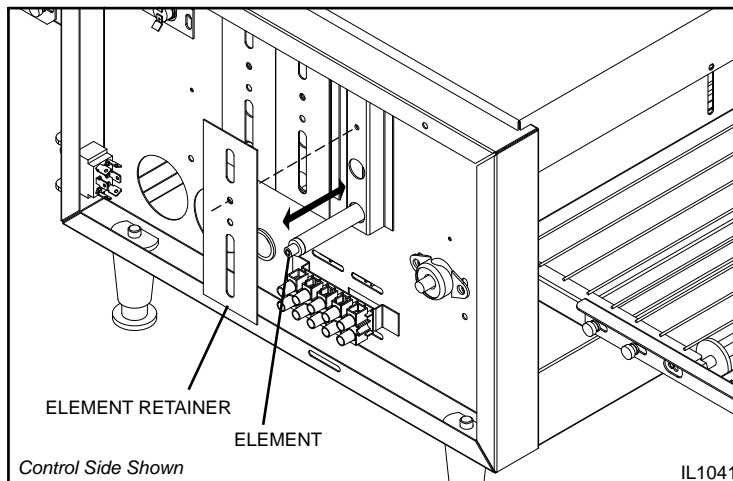

### B. REPLACING FAN MOTOR

- 1) **DISCONNECT POWER SOURCE.**
- 2) After unit has cooled, remove the crumb tray, and turn unit over so the bottom is facing upward. **Never place unit on its side.**
- 3) Remove the control box cover which contains the fan motor, by removing the 2 screws.
- 4) Unplug power supply cord from fan motor.
- 5) Remove (4) screws, which hold fan motor and grill to the control box cover and remove fan.
- 6) Once removed, clean fan grill and control box cover using warm soapy water.
- 7) Put replacement motor and grill in place and secure to the control box cover with screws previously removed.
- 8) Reconnect power supply cord to fan motor.
- 9) Replace back panel and enclosure. Fasten with screws removed in step 3.
- 10) Connect unit to power source, reinstall the crumb tray and test unit for proper operation.

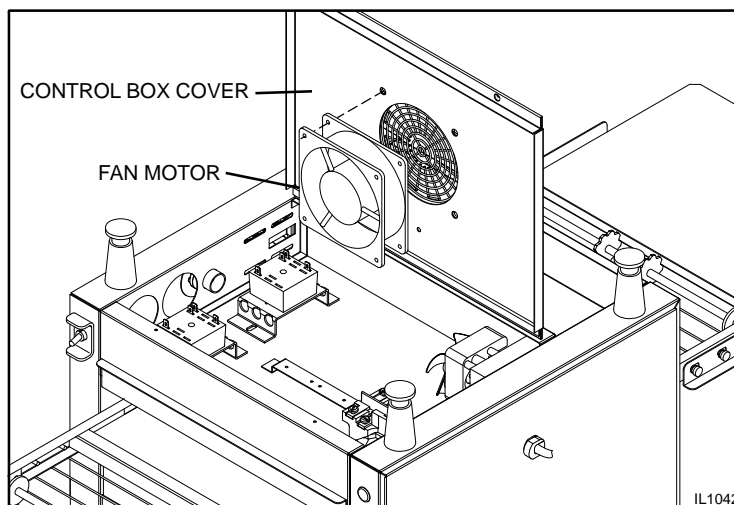

### C. REPLACING BELT DRIVE MOTOR

- 1) **DISCONNECT POWER SOURCE.**
- 2) After unit has cooled, remove the crumb tray, and turn unit over so the bottom is facing upward. **Never place unit on its side.**
- 3) Remove the control box cover which contains the fan motor, by removing the (2) screws.
- 4) Remove the side panel that will expose the drive chain and sprockets.
- 5) Remove sprocket from motor shaft, using an Allen wrench and loosening the set-screw.
- 6) Remove the wire from terminal block connecting the drive motor to the internal wiring. On units rated 208 or 240 volts, note which color leads are being used for these connections and which lead is capped with glass tape. The new motor should use the same arrangement. Reference the wiring diagram if needed.
- 7) Remove screws holding motor in place and remove motor from unit.
- 8) Put new motor in place and attach loosely with mounting screws.
- 9) Replace sprocket on motor shaft.

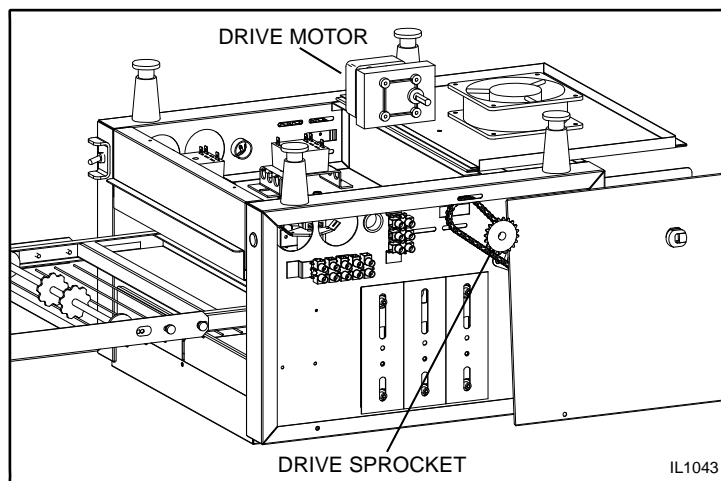

**NOTE: The two sprockets must line up FLUSH with each other, so the chain does not twist any during operation. Also the hub gets installed closets to the motor.**

## MAINTENANCE PROCEDURES continued

- Slide motor until the drive chain has about 1/4" slack when lightly pushed at the center of its top open run.  
*See chain tensioning illustration.*
- Tighten screws to secure motor.
- Rewire leads same as removed in step 6.
- At this time you may plug unit in and test for proper operation prior to reinstalling panels and turning unit back over onto its feet.
- If unit is working correctly, turn unit off and unplug until completed.
- Reinstall side panels and control box cover.  
Place unit back into its upright position.  
Reinstall the crumb tray.
- Connect unit to power source and test unit for proper operation.

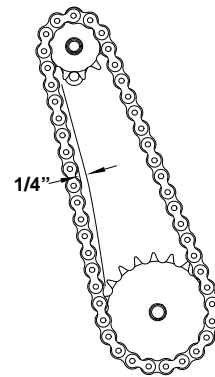

Chain Tension

### D. REPLACING SPEED CONTROL

- DISCONNECT POWER SOURCE.**
- Remove the speed control knob and the locking nut holding the speed control in place.
- Remove right side panel, by removing the truss head screws. Pull the top of the panel out slightly and lift up.
- Wires from the speed control go into a terminal block located on the side of the chassis. Remove the wires from the control and insert wires for the new speed control into the same positions as shown on the wiring diagram.
- Install the washer onto the shaft of the speed control, followed by the installation.
- When mounting the speed control in the side panel be sure to position the anti-rotation pin in the slot as shown.
- Tighten the speed control assembly by using the locking nut, followed by the control knob.
- Reinstall the side panel and tighten with the screws previously removed.

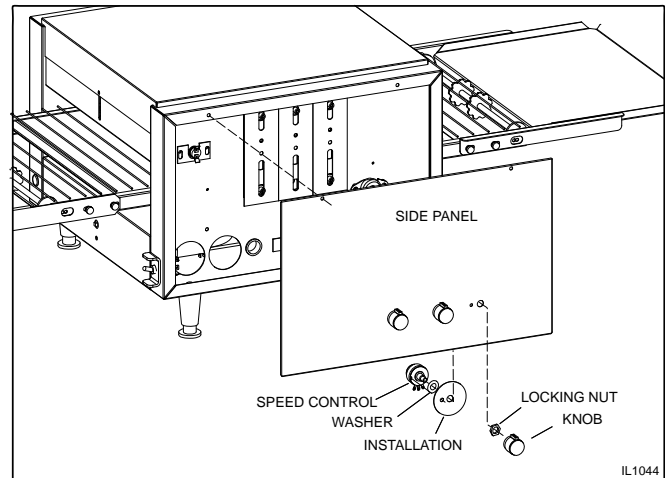

### E. CLEANING AIR INTAKE ONCE A WEEK.

- DISCONNECT UNIT FROM POWER SOURCE.**
- Place unit upside down. **NOTE: You may damage the Heatertubes, by placing unit on its side.**
- Use a vacuum cleaner and or a damp cloth to clean the air intake.  
This procedure should be done at least once a week.

### F. LUBRICATE THE CHAIN & SPROCKETS EVERY 6 MONTHS

- DISCONNECT UNIT FROM POWER SOURCE.**
- Remove the side panels which exposes chain drive.
- Using an extreme pressure, synthetic chain lubricant with a temperature range up to 400°F. Apply liberally onto chain and sprockets.  
This grease is available separately as part no. **1P-Z8914. Call (314) 678-6303 to order.**
- Replace side panels, Reconnect power source and test unit.

## TROUBLESHOOTING GUIDE

### A. UNIT WILL NOT HEAT, CONVEYOR BELT WILL NOT MOVE.

- 1) Be sure the main circuit breaker is switched to the ON position and there is power to the outlet.
- 2) Check to see if the oven is plugged in and all controls are turned to the ON position.
- 3) Be sure the Hi-Limit Reset Button is pushed in.
- 4) Call the Star Service Help Desk at (314) 634-6303.

### B. UNIT WILL NOT HEAT, CONVEYOR TURNS PROPERLY.

- 1) Check to see if the top and bottom heat controls have been turned to the maximum setting.
- 2) Press the Hi-Limit Reset Button located underneath the conveyor belt on the inlet side. If this reactivates the heater tubes, see Hi-Limit Reset Section below.
- 3) If not, call the Star Service Help Desk at (314) 634-6303.

### C. HI-LIMIT (HEAT) RESET.

Your Holman conveyor oven is equipped with an automatic activated temperature limit switch which interrupts the heater tube connections if the air temperature in the control box exceeds 190°F (88°C). This limit switch can be reset manually by pushing the button in the center of the switch which is located on the power cord side panel, on older models its on the right side under the conveyor belt. See Oven Components on Page 7 for location. Unit will not reset until internal temperature has fallen below 190°F (88°C).

**NOTE: THE HI-LIMIT SWITCH CAN BE ACTIVATED IF THERE IS NOT A PROPER AMOUNT OF AIR FLOW BEING GENERATED BY THE COOLING FAN. IF THIS OCCURS:**

- 1) **DISCONNECT UNIT FROM POWER SOURCE.**
- 2) Check to see if the air intake area (center of the control box, bottom of unit) is free of dust, grease or other obstructions.
- 3) Check to see if crumb trays (heat reflectors) are in place. If the Hi-Limit Switch can not be reset, call the Star Service Help Desk at (314) 634-6303.



### CAUTION

**NEVER OPERATE UNIT WITHOUT CRUMB TRAYS IN POSITION AS THIS CAUSES OVERHEATING IN THE CONTROL BOX.**

### D. CONVEYOR WILL NOT TURN, UNIT HEATS PROPERLY.

To check for mechanical binding:

- 1) **DISCONNECT UNIT FROM POWER SOURCE.**
- 2) Check to see if there are obstructions in the conveyor system that may cause a jam. If so, remove obstruction.
- 3) Check power supply & terminal blocks for loose or disconnected wires.
- 4) Remove right side panel and drive motor sprockets, see illustration. Manually move conveyor belt to check for mechanical binding. If conveyor belt moves freely, call the Star Service Help Desk at (314) 634-6303. The drive motor or speed control may have to be replaced.

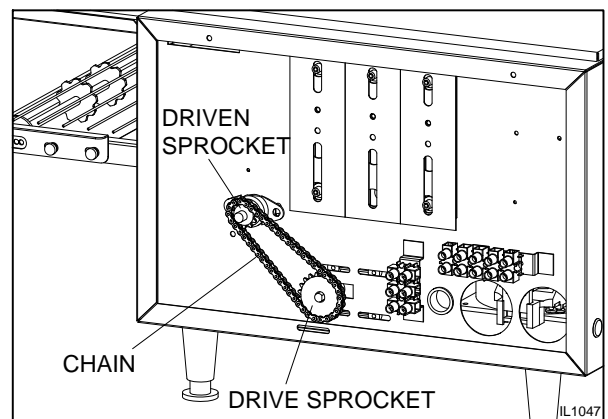

### E. CONVEYOR TURNS AT ONE SPEED REGARDLESS OF SPEED CONTROL SETTING.

- 1) Call the Star Service Help Desk at (314) 634-6303, as speed control **MAY** need replacing. Refer to **REPLACING SPEED CONTROL** in the previous section.

### F. COOLING FAN DOES NOT START

- 1) Remove control box cover and check fan blade for obstruction.
- 2) Check electrical connections are secure and complete.
- 3) Call the Star Service Help Desk at (314) 634-6303, as the fan switch and or fan motor **MAY** need replacing. Refer to **REPLACING FAN MOTOR** in the previous section.

# WIRING DIAGRAMS

All wiring diagrams on the following pages are those of current and obsolete design models, and may not represent current production. To determine which diagram goes with your unit, reference the nameplate located on the cord side of the unit, and use the table below.

Call the Star Service Help Desk at (314) 634-6303, if you have questions, or unable to determine your models diagram.

## WIRING DIAGRAMS TABLE OF CONTENTS

DESCRIPTION	PAGE
210HX/214HX, 120V, 50/60Hz, 4-Tube, Wired Series	14
210HX, 120V, 60Hz, 4-Tube, Wired Series, Canada	15
210HX/214HX, 208/220/240V, 50/60Hz, 3.2Kw, 4-Tube, Wired Series	15
214HX, 220V, 50/60Hz, 3.6Kw, 4-Tube, Wired Series	15
214HX, 208V, 60Hz, 4.0Kw, 4-Tube, Wired Series	15
214HX, 208V, 60Hz, 4.5Kw, 4-Tube, Wired Series	15
210HX, 120V, 60Hz, 4-Tube, Wired Parallel	16
214HX, 240V, 50Hz, 4-Tube, Wired Parallel	16
214HXR, 240V, 50Hz, 4.5Kw, 4-Tube, Wired Parallel	16
214HX, 208/240V, 50/60Hz, 3.6Kw, 4-Tube, Wired Parallel	16
214HX, 208/220/240V, 50/60Hz, 5-Tube, Wired Parallel	17
214HX, 208/220/240V, 50/60Hz, 4.0Kw, 5-Tube, Wired Parallel	17
214HX, 208V, 60Hz, 4.5Kw, 5-Tube, Wired Parallel	17
214HX, 208/240V, 60Hz, 4.5Kw, 6-Tube, Wired Parallel	18
210/214HX, 208/240V, 50Hz, CE, 4-Tube, Wired Series	19
210/214HX, 208/240V, 50Hz, 4-Tube, Wired Parallel	20

### HEAT CONTROLS

There is one control for each heat control knob. These are located in the control box. To determine what type of heat controls your unit is equipped with, follow these easy instructions.

1. If your unit is equipped with a Pilot Light your unit is a Temp Control unit, if it does not have a Pilot Light, you have a Phase Control unit.

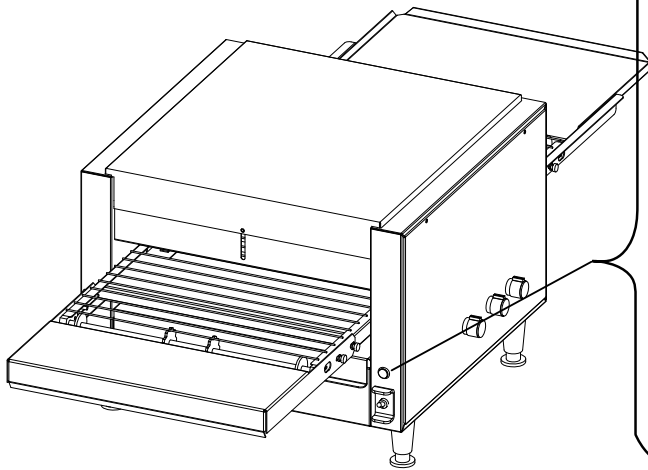

#### PHASE CONTROL

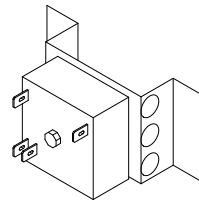

Phase Control



2 Wired Potentiometer

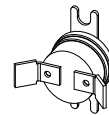

Fan Switch

#### TEMP CONTROL

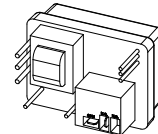

Temp Control



3 Wired Potentiometer

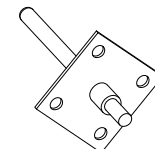

Temperature Probe

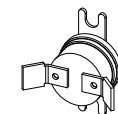

Fan Switch

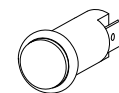

Pilot Light

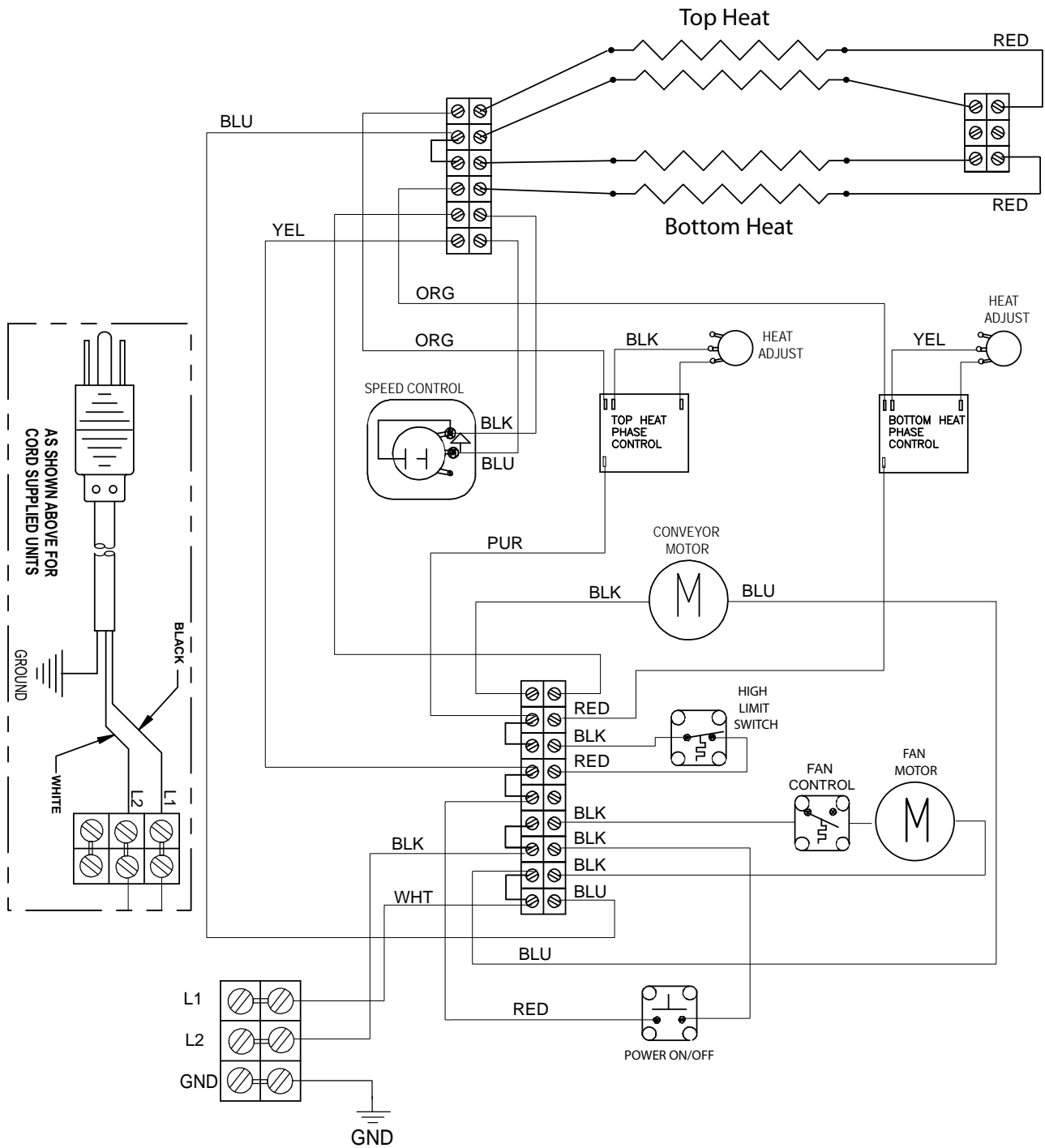

**MODEL:**  
 210HX, 120V, 50/60Hz, 4-Tube, Wired Series  
 214HX, 120V, 60Hz, 4-Tube, Wired Series

THIS DRAWING CONTAINS INFORMATION CONFIDENTIAL TO STAR MFG. INT'L. INC.  
 NO REPRODUCTION OR DISCLOSURE OF ITS CONTENTS IS PERMITTED.



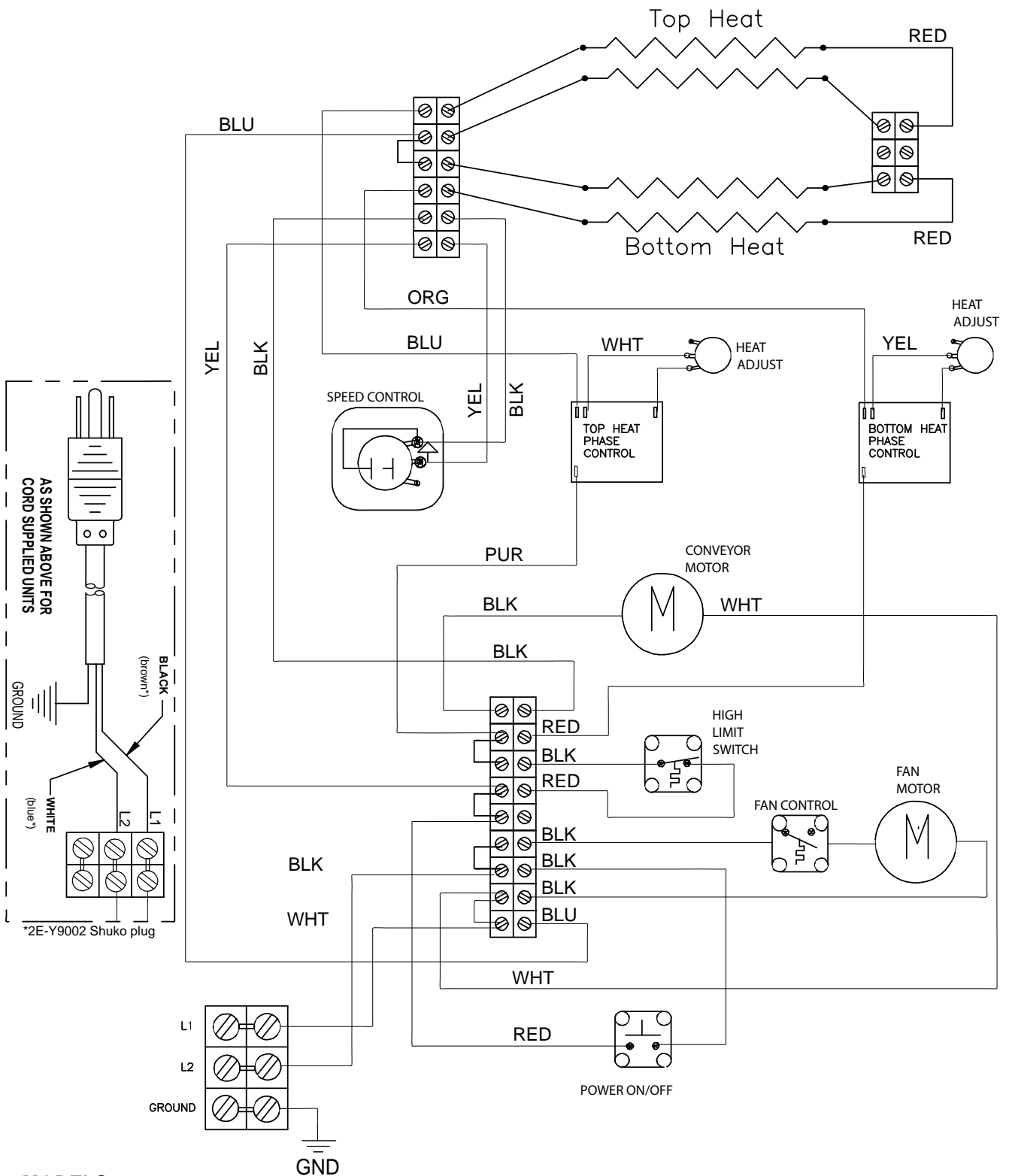

- MODELS:**  
 210HX, 120V, 60Hz, 4-Tube, Wired Series, Canada  
 210HX(P)/214HX, 208,220,240V, 50/60Hz, 3.2 Kw, 4-Tube, Wired Series  
 214HX, 220V, 50/60Hz, 3.6 Kw, 4-Tube, Wired Series  
 214HX, 208V, 60Hz, 4.0 Kw, 4-Tube, Wired Series  
 214HX, 208V, 60Hz, 4.5 Kw, 4-Tube, Wired Series  
 214HXB, 240V, 60Hz, 4.5Kw, 4-Tube, Wired Series

THIS DRAWING CONTAINS INFORMATION CONFIDENTIAL TO STAR MFG. INT'L. INC.  
 NO REPRODUCTION OR DISCLOSURE OF ITS CONTENTS IS PERMITTED.



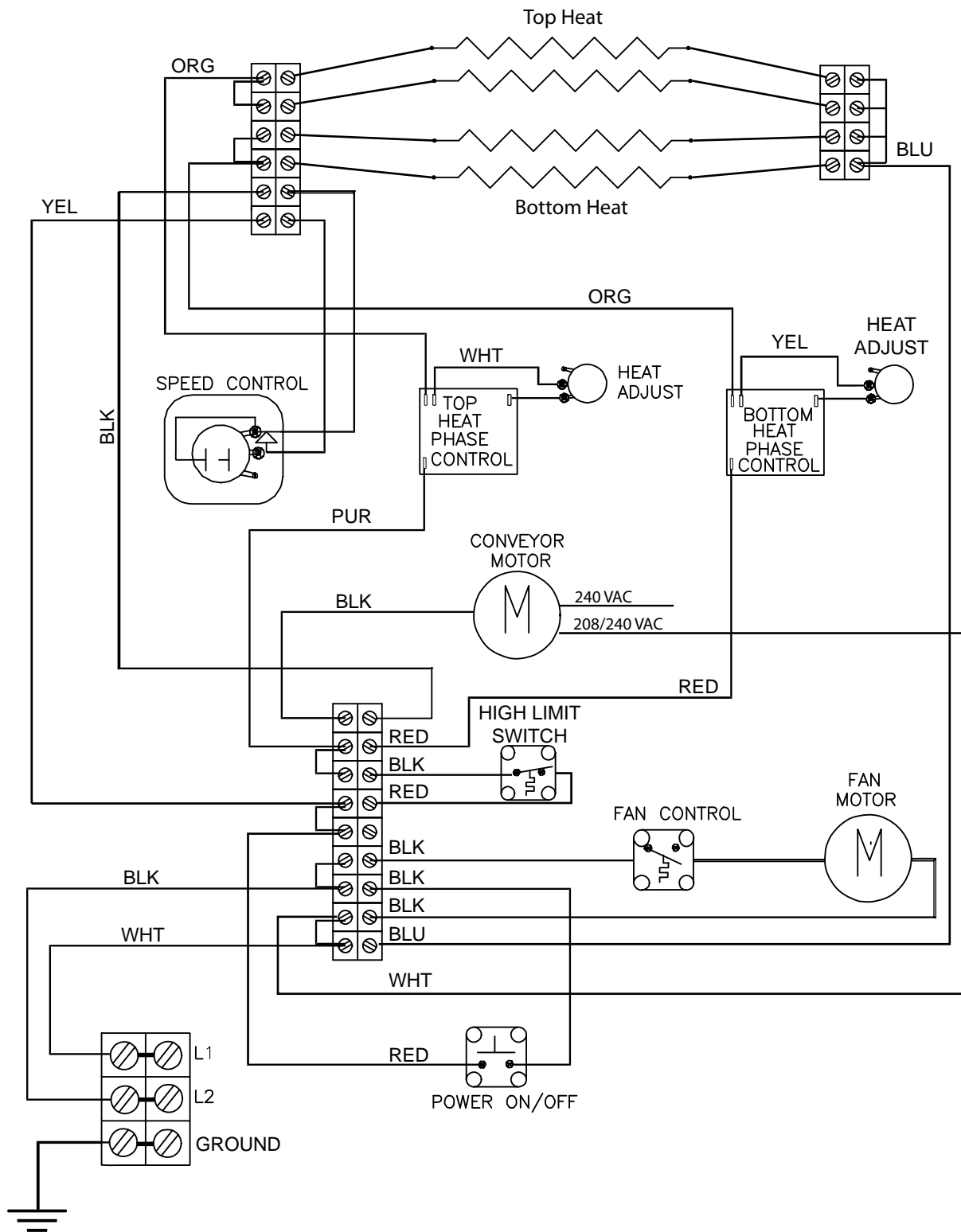

**MODEL:**

- 210HX, 120V, 60Hz, 4-Tube, Wired Parallel
- 214HX, 240V, 50Hz, 4-Tube, Wired Parallel
- 214HXR, 240V, 50Hz, 4.5Kw, 4-Tube, Wired Parallel
- 214HX, 208/240V, 50/60Hz, 3.6Kw, 4-Tube, Wired Parallel



020014 Rev A 11/17/2005

THIS DRAWING CONTAINS INFORMATION CONFIDENTIAL TO STAR MFG. INT'L. INC.  
NO REPRODUCTION OR DISCLOSURE OF ITS CONTENTS IS PERMITTED.





STAR MANUFACTURING INTERNATIONAL, INC.  
#10 SUNNEN DRIVE, ST. LOUIS, MO. 63143, USA

DR. DE CK. RDL DATE 4/13/09

MATERIAL FINISH

MODEL NO. 214HX4.0

PART NO. SK-2415

TOLERANCES UNLESS OTHERWISE NOTED FRACTIONS ±1/64 DECIMALS ±.015 ANGLES ±1° THIS DRAWING CONTAINS INFORMATION CONFIDENTIAL TO STAR MFG. INT'L. INC. NO REPRODUCTION OR DISCLOSURE OF ITS CONTENTS IS PERMITTED.

REVISIONS LTR DATE DESCRIPTION OF CHANGE DR

# SK-2415

60 Hz, 4.0 kW 208/240 VAC SINGLE PHASE 5 TUBE

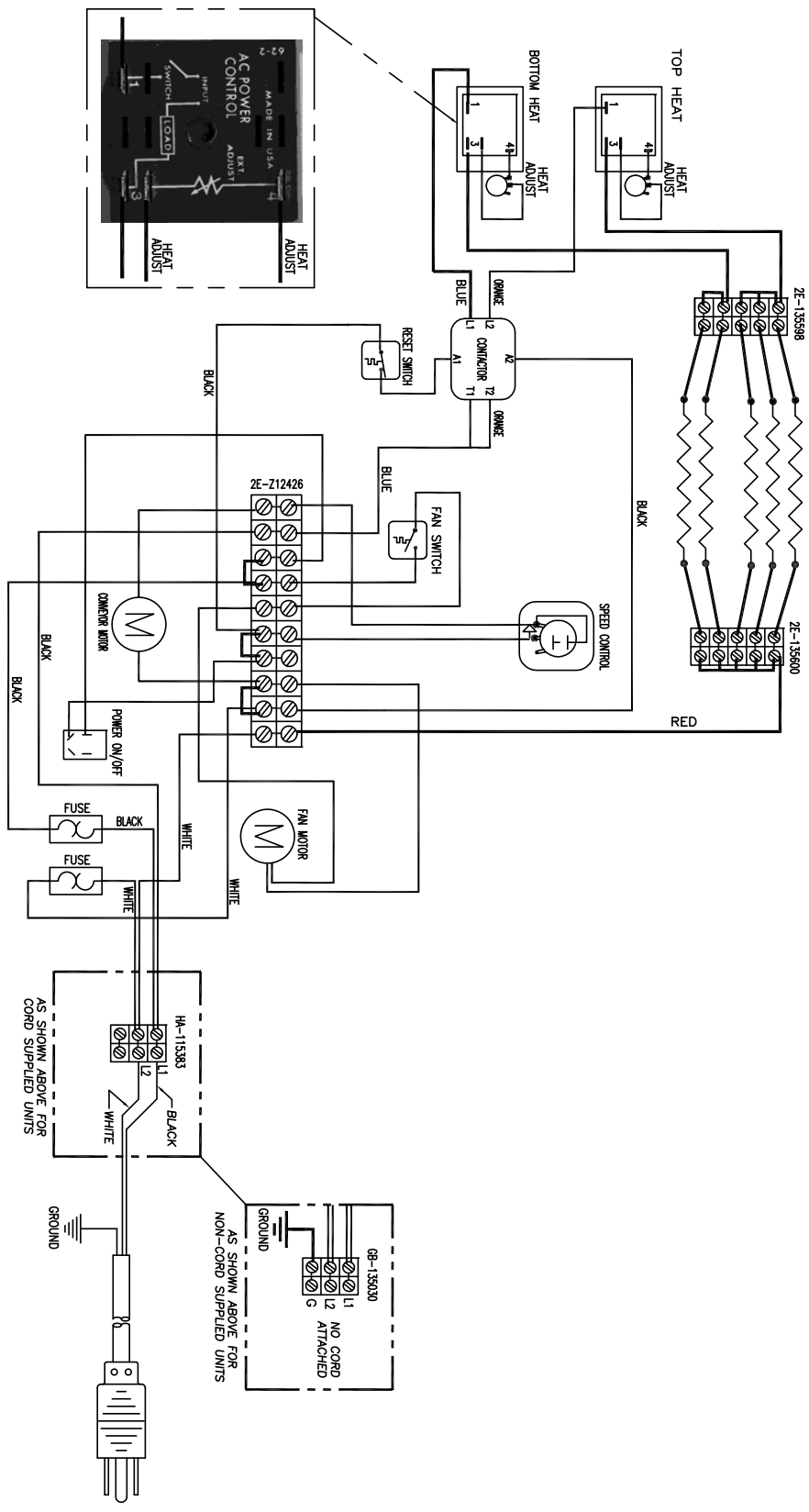

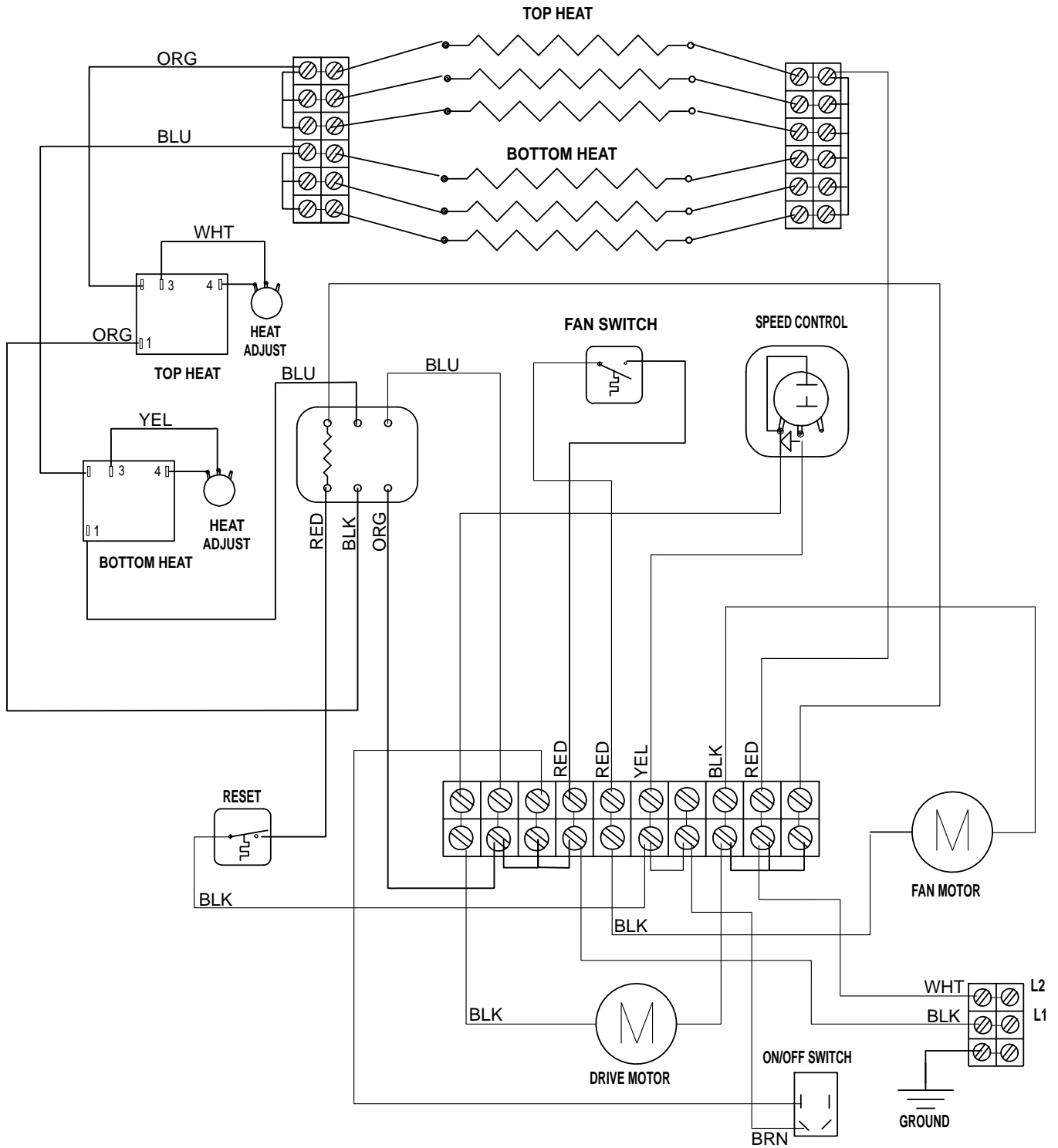

**MODEL:**  
 214HX, 208/240V, 60Hz, 4.5Kw, 6-Tube, Wired Parallel



020175 Rev - 9/11/2002

THIS DRAWING CONTAINS INFORMATION CONFIDENTIAL TO STAR MFG. INT'L. INC.  
 NO REPRODUCTION OR DISCLOSURE OF ITS CONTENTS IS PERMITTED.

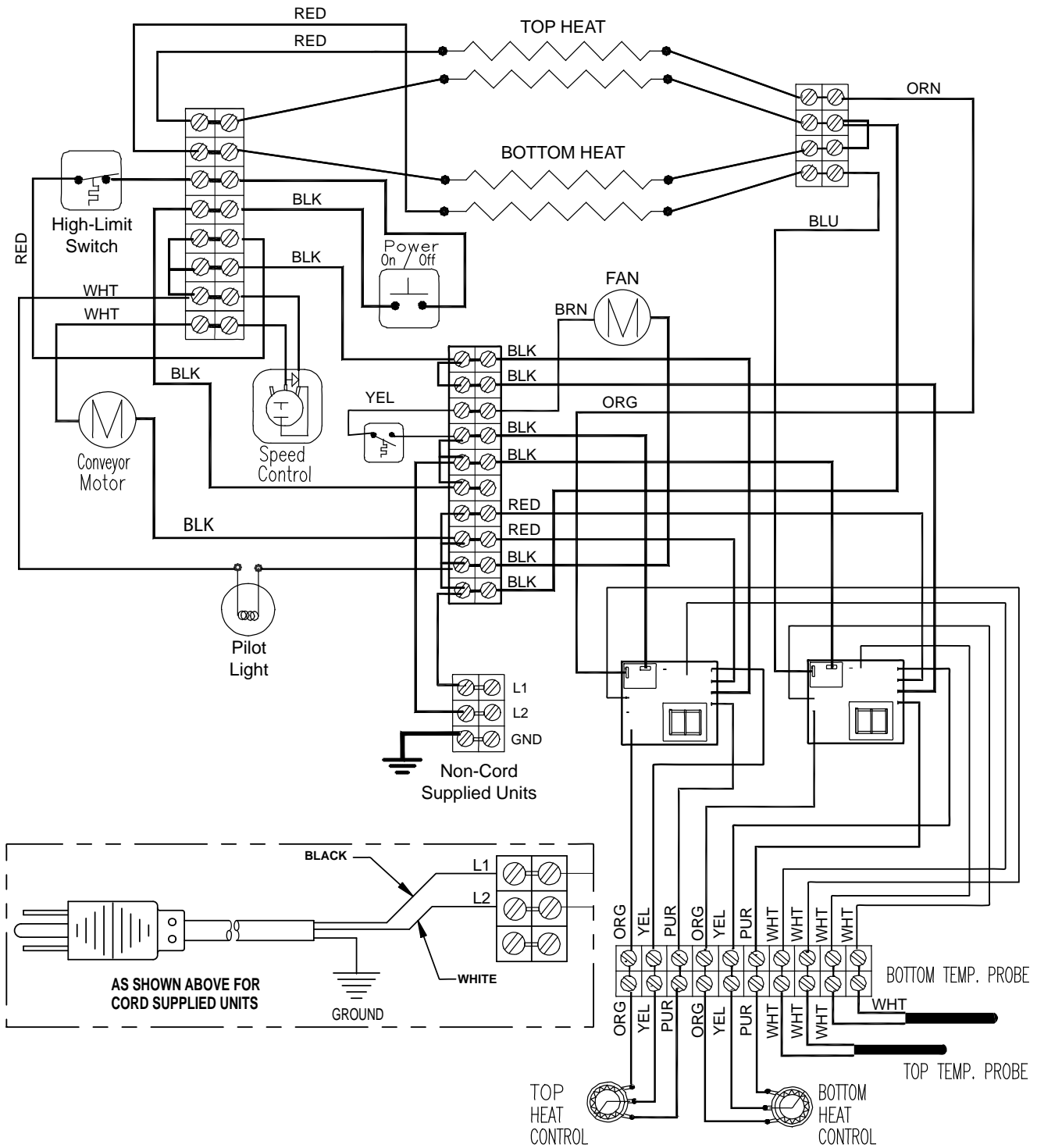

**MODEL:**  
210/214HX, 208/240V, 50Hz, CE, 4-Tube, Wired Series



THIS DRAWING CONTAINS INFORMATION CONFIDENTIAL TO STAR MFG. INT'L. INC.  
NO REPRODUCTION OR DISCLOSURE OF ITS CONTENTS IS PERMITTED.

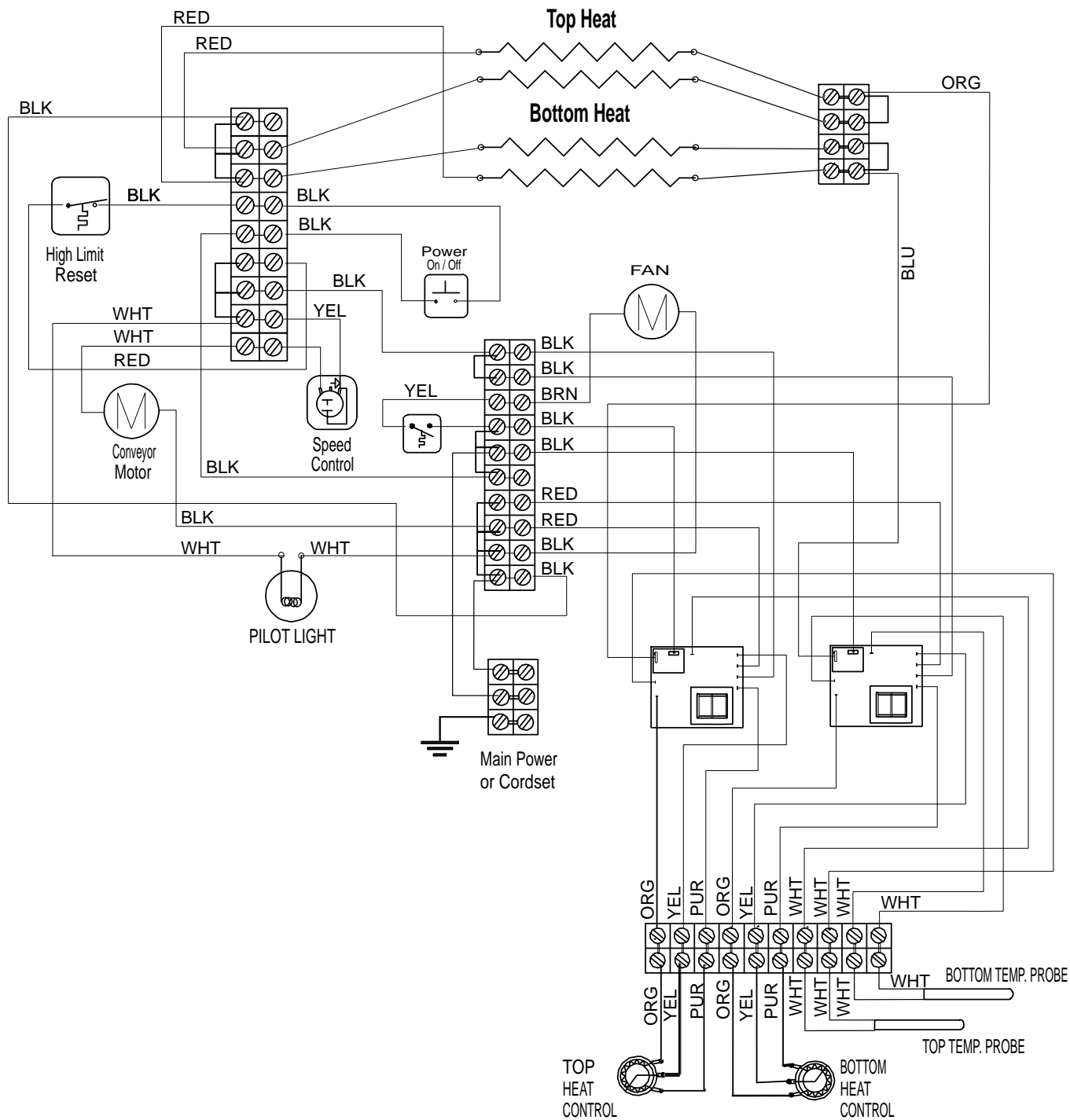

**MODEL:**  
210HX/214HX, 208/240V, 50Hz, 4-Tube, Wired Parallel



THIS DRAWING CONTAINS INFORMATION CONFIDENTIAL TO STAR MFG. INTL. INC.  
NO REPRODUCTION OR DISCLOSURE OF ITS CONTENTS IS PERMITTED.

### THOROUGHLY INSPECT YOUR UNIT ON ARRIVAL

This unit has been tested for proper operation before leaving our plant to insure delivery of your unit in perfect condition. However, there are instances in which the unit may be damaged in transit. In the event you discover any type of damage to your product upon receipt, you must immediately contact the transportation company who delivered the item to you and initiate your claim with same. If this procedure is not followed, it may affect the warranty status of the unit.

### LIMITED EQUIPMENT WARRANTY

All workmanship and material in Star products have a one (1) year limited warranty on parts & labor in the United States and Canada. Such warranty is limited to the original purchaser only and shall be effective from the date the equipment is placed in service. Star's obligation under this warranty is limited to the repair of defects without charge, by the factory authorized service agency or one of its sub-agencies. Models that are considered portable (*see below*) should be taken to the closest Star service agency, transportation prepaid.

- > Star will not assume any responsibility for loss of revenue.
- > On all shipments outside the United States and Canada, see International Warranty.
- \* The warranty period for the Ultra-Max, Hot Plates, Griddles, Charbroilers is (3) years parts & labor.
- \* The warranty period for the Star-Max, Charbroilers, Griddles, Hot Plates, Fryers & Finishing Oven is (2) years parts & labor.
- \* The warranty period for the JetStar six (6) ounce & Super JetStar eight (8) ounce series popcorn machines is two (2) years.
- \* The warranty period for the Chrome-Max Griddles is five (5) years on the griddle surface. See detailed warranty provided with unit.
- \* The warranty period for Teflon/Dura-Tec coatings is one year under normal use and reasonable care. This warranty does not apply if damage occurs to Teflon/Dura-Tec coatings from improper cleaning, maintenance, use of metallic utensils, or abrasive cleaners, abrasive pads, product identifiers and point-of-sale attachments, or any other non-food object that comes in continuous contact with the roller coating. This warranty does not apply to the "non-stick" properties of such materials.
- > This warranty does not apply to "Special Products" but to regular catalog items only. Star's warranty on "Special Products" is six (6) months on parts and ninety (90) days on labor.
- > This warranty does not apply to any item that is disassembled or tampered with for any purpose other than repair by a Star Authorized Service Center or the Service Center's sub-agency.
- > This warranty does not apply if damage occurs from improper installation, misuse, wrong voltage, wrong gas or operated contrary to the Installation and Operating instructions.
- > This warranty is not valid on Conveyor Ovens *unless* a "start-up/check-out" has been performed by a Factory Authorized Technician.

### PARTS WARRANTY

Parts that are sold to repair out of warranty equipment are warranted for ninety (90) days. The part only is warranted, the labor to replace the part is **NOT** warranted.

### SERVICES NOT COVERED BY WARRANTY

1. Travel time and mileage rendered beyond the 50 mile radius limit
2. Mileage and travel time on portable equipment (*see below*)
3. Labor to replace such items that can be replaced easily during a daily cleaning routine, ie; removable kettles on fryers, knobs, grease drawers on griddles, etc.
4. Installation of equipment
5. Damages due to improper installation
6. Damages from abuse or misuse
7. Operated contrary to the Operating and Installation Instructions
8. Cleaning of equipment
9. Seasoning of griddle plates
10. Voltage conversions
11. Gas conversions
12. Pilot light adjustment
13. Miscellaneous adjustments
14. Thermostat calibration and by-pass adjustment
15. Resetting of circuit breakers or safety controls or reset buttons
16. Replacement of bulbs
17. Replacement of fuses
18. Repair of damage created during transit, delivery, & installation OR created by acts of God

### PORTABLE EQUIPMENT

Star will not honor service bills that include travel time and mileage charges for servicing any products considered "Portable" including items listed below. These products should be taken to the Service Agency for repair:

- \* The Model 510FD, 510FF Fryer.
- \* The Model 526TOA Toaster Oven.
- \* The Model J4R, 4 oz. Popcorn Machine.
- \* The Model 518CMA & 526CMA Cheese Melter.
- \* The Model 12MC & 15MC & 18MCP Hot Food Merchandisers.
- \* The Model 12NCPW & 15NCPW Nacho Chip/Popcorn Warmer.
- \* All Hot Dog Equipment **except Roller Grills & Drawer Bun Warmers.**
- \* All Nacho Cheese Warmers **except Model 11WLA Series Nacho Cheese Warmer.**
- \* All Condiment Dispensers **except the Model HPD & SPD Series Dispenser.**
- \* All Specialty Food Warmers **except Model 130R, 11RW Series, and 11WSA Series.**
- \* All QCS/RCS Series Toasters **except Model QCS3 & RCS3 Series.**
- \* All Fast Steamer Models **except Direct Connect Series.**

### ALL:

- \* Pop-Up Toasters
- \* Butter Dispensers
- \* Pretzel Merchandisers  
(Model 16PD-A Only)
- \* Pastry Display Cabinets
- \* Nacho Chip Merchandisers
- \* Accessories of any kind
- \* Sneeze Guards
- \* Pizza Ovens  
(Model PO12 Only)
- \* Heat Lamps
- \* Pumps-Manual

The foregoing warranty is in lieu of any and all other warranties expressed or implied and constitutes the entire warranty.

### FOR ASSISTANCE

Should you need any assistance regarding the Operation or Maintenance of any Star equipment; write, phone, fax or email our Service Department. In all correspondence mention the Model number and the Serial number of your unit, and the voltage or type of gas you are using.

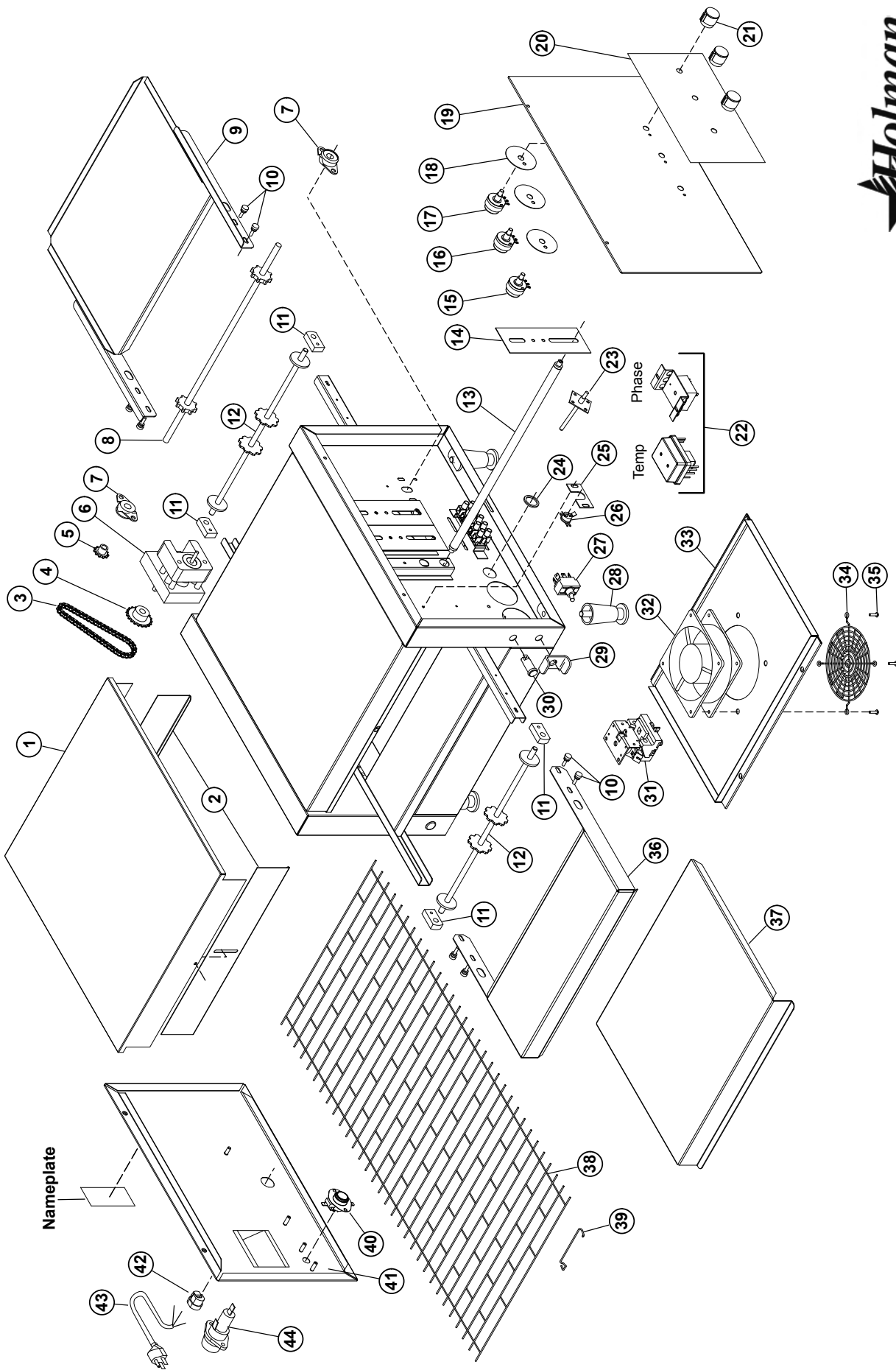

SK2150 Rev. B 9/14/09

**MODEL: MINIVEYOR**  
210HX, 214HX





# 214HX Series Holman Conveyor Oven

Fig No.	Part No.	Quantity Per	Description	Fig No.	Part No.	Quantity Per	Description
1	GB-401288	1	Top Cover	23	2J-200568	2	Heat Probe
2	HM-400899	1	Heat Shutter	24	1P-E1299	12in	Edging, 16-18 GA. SS (for both holes)
3	2P-150001	1	Drive Chain, 12 in.	25	HG-402144	1	Fan Switch Bracket
4	2P-Z8779	1	Drive Sprocket (11 tooth) .313 ID	26	2E-200574	1	Fan Switch
	2P-200646	1	Drive Sprocket (20 tooth)	27	2E-200543	1	On/Off Switch
	2P-200653	1	Drive Sprocket (20 tooth)	28	2R-200716	4	Legs, 2 1/2"
	2P-Z8779	1	Drive Sprocket (11 tooth)	29	2P-401780	1	Guard, Toggle Switch
5	2P-200653	1	Driven Sprocket	30	2J-200427	1	Pilot Light, CE Only
	2P-115362	1	Driven Sprocket (11 tooth) 214HXRC, HXARC, HXETB, HXR	31	2E-Z8966	1	Contact; Relay
	2P-Z8779	1	Driven Sprocket (11 tooth) 214HXRRRCM, 214HXRCM	32	2U-200561	1	Motor, Fan 240V 23BTM
6	2U-Z11871	1	Drive Motor, (R-L), CCW 214HXR	32	2U-200559	1	Motor, Fan 120V 12A12-BTM
	2U-Z11870	1	Drive Motor, (L-R), CW 214HXR, HXRRRCM, HXRRCM	33	HM-401498	1	Control Box Cover
	2U-Z13803	1	Motor, Drive 120V (L-R) CW 120V	34	2R-200562	1	Fan Grill
	2U-200590	1	Drive Motor, 3286 BB 220V, 50Hz	35	2C-Z5883	4	Screw, Fan Grill
7	GB-112262	2	Bearings	36	HM-401096	1	Extended Nose Guard
8	2A-100907	1	Drive Shaft	37	HM-402787	1	Crumb Tray
9	GB-101402	1	Unload Tray	38	GB-160007	1	Conveyor Belt, 14" Wide
10	2C-200015	8	Screws, 8-32x3/8 Knurled	39	2B-200603	3	Master Links
11	2P-200693	4	Extension Bushing	40	2E-200566	1	Reset Switch
12	2A-202905	2	Idle Shaft	41	GB-Z10058	1	Side Pnl, L-R (cord) w/side Hi-Limit 12/3 Cord Set
13	<b>SEE ELEMENT CHART</b>						
14	GB-402245	6	Retainers, Quartz Elements		GB-Z10058-2	1	Side Pnl, R-L (cord) w/side Hi-Limit 12/3 Cord Set
	GB-402444	6	Retainers, Metal Elements		GB-Z10055	1	Side Pnl, L-R (cord) w/side Hi-Limit 14/3, 16/3 Cord Set
	GA-402129	4	Retainer, Quartz Elements		GB-Z10055-2	1	Side Pnl, R-L (cord) w/side Hi-Limit 14/3, 16/3 Cord Set
	GB-Z9864	1	Retainer, 6 Metal Elements		GB-401524	1	Side Pnl, (cord) w/o side Hi-Limit
15	SP-115341	1	Heat Control Assy. (Bottom) CE Only		GB-Z9862	1	Side Pnl, (cord) HXETB, HXRET
	SP-115343	1	Heat Control Assy. (Bottom) 120V	42	2K-Y6764	1	Bushing, Cord 12/3 Cord Set
	2J-200567	1	Heat Control Assy. (Bottom) TEMP CE Only		2K-Y2968	1	Bushing, Cord 14/3 & 16/3 Cord Set
16	SP-115340	1	Heat Control Assy. (Top) 120V	43	2E-200375	1	Cord Set, 14/3
	SP-115342	1	Heat Control Assy. (Top) TEMP CE Only		2E-200376	1	Cord Set, 14/3
	2J-200567	1	Speed Control 208/220/240V		2E-200374	1	Cord Set, 12/3
17	GB-118062	1	Insulation, Switch Pot. CE Only		2E-Y9002	1	Cord Set, 16/3
18	2E-200180	3	Insulation, (controls) 208/220/240V	44	HG-Z16423	1	Cord Set, BS 546
19	GB-401328	1	Side Pnl, (controls) mfg before 11/07HXETB, HXRET		2E-30901-08	2	Fuse Hldr for SC Fuse
19	GB-Z9861	1	Control Label		2E-Z5680	2	FUISE - CLASS G (5amp)
20	2M-200818	1	Control Label		2E-200387	1	Cord, Cooling Fan
	2M-200819	1	Control Label	NI	2P-115501	AR	Jumpers (2 Position)
	2M-Z9876	1	Control Label	NI	2P-115502	AR	Jumpers (3 Position)
21	SP-115360	3	Knob Assembly	NI	GE-115503	AR	Jumpers (4 Position)
	2R-200708	3	Cap, Knob (included in #21)	NI	HA-115383	AR	Block, Terminal (3 Position)
	2R-200713	3	Skirt, Knob (included in #21)	NI	HC-115381	AR	Block, Terminal (4 Position)
	2R-200768	3	Knob Control (Included in #21)	NI	HK-115388	AR	Block, Terminal (6 Position)
22	SP-115339	2	Control, Phase	NI	HB-115387	AR	Block, Terminal (8 Position)
	SP-115347	2	Control, Temp CE Only	NI	<b>1L-Z12397</b>	1	Multipurpose Synthetic Grease (80°F TO 400°F), tube 1 oz.

NI = NOT ILLUSTRATED, AR = AS REQUIRED

Rev. J 5/23/2013





# 210HX & 214HX Series Element Chart

ELEMENT CHART					
Fig. No	Part No	Qty	Desc	Unit Voltage	Unit Amp Draw
<b>210HX</b>					
13	GA-199100 NLA	4	Heater Tube (430W, 3.58A)	120V (Metal)	14.3
	GH-197848	4	Heater Tube (7.86Ω, 425W, 3.54A)	120V (Quartz)	14.2
	2N-209197	4	Heater Tube (700W, 3.36A)	208V (Metal)	13.4
	HO-197841	4	Heater Tube (14.5Ω, 700W, 3.36A)	208V (Quartz)	13.4
	HT-197845	4	Heater Tube (800W, 3.84A)	208V (Quartz)	15.4
	HO-197844	4	Heater Tube (15.84Ω, 700W, 3.18A)	220V (Quartz)	12.7
	HT-197846	4	Heater Tube (800W, 3.63A)	220V (Quartz)	14.5
	HO-199106	4	Heater Tube (700W, 2.91A)	240V (Metal)	11.6
	HO-197842	4	Heater Tube (19.2Ω, 700W, 2.91A)	240V (Quartz)	11.6
	HT-187847	4	Heater Tube (800W, 3.33A)	240V (Quartz)	13.3
<b>214HX</b>					
13	GC-197855	4	Heater Tube (16.66Ω, 432W, 3.6A)	120V (Quartz)	14.4
	2N-Z11215*	5	Heater Tube (51.02Ω, 800W, 3.85A)	208V (Metal Extended) HXETB & HXRET B	19.2
		5	Heater Tube (51.02Ω, 800W, 3.85A)		19.3
	2N-209130	6	Heater Tube (51.02Ω, 800W, 3.85A)	208V (Metal)	23.1
		3			13.1
	HT-197851	4	Heater Tube (59.0Ω, 909W, 4.37A)	208V (Quartz)	17.5
		5			21.9
	HT-197845	4	Heater Tube (104V, 810W, 3.89A) Series	208V (Quartz)	31.1
	GB-197900	5	Heater Tube (50.8Ω, 800W, 3.86A)	208V (Quartz)	19.3
	HT-197846	4	Heater Tube (110V, 850W, 3.86A) Series	220V (Quartz)	30.9
	GB-198037	5	Heater Tube (56.8Ω, 800W, 3.65A)	220V (Quartz)	18.3
	2N-Z11216*	5	Heater Tube (68Ω, 800W, 3.33A)	240V (Metal Extended) HXETB & HXRET B	16.7
	2N-209160	5	Heater Tube (68Ω, 800W, 3.33A)	240V (Metal)	16.6
		3			11.5
	HT-197850	4	Heater Tube (59.0Ω, 921W, 3.84A)	240V (Quartz)	15.4
5			19.2		
GB-197847	4	Heater Tube (120V, 810W, 6.75A) Series	240V (Quartz)	27	
HT-197852	4	Heater Tube (13.49Ω, 1000W, 4.16A)	240V (Quartz) CE	16.6	
HX-197895	5	Heater Tube (66.5Ω, 815W, 3.4A)	240V (Quartz)	15.6	

\* = Not interchangeable on HXTB units





STAR INTERNATIONAL HOLDINGS INC. COMPANY  
Star - Holman - Lang - Wells - Bloomfield - Toastmaster  
10 Sunnen Drive, St. Louis, MO 63143 U.S.A.  
(314) 678-6303  
[www.star-mfg.com](http://www.star-mfg.com)