

**OPERATOR'S MANUAL
HOLMAN CONVEYOR OVENS
MODEL 314HXM**

PARTS LIST

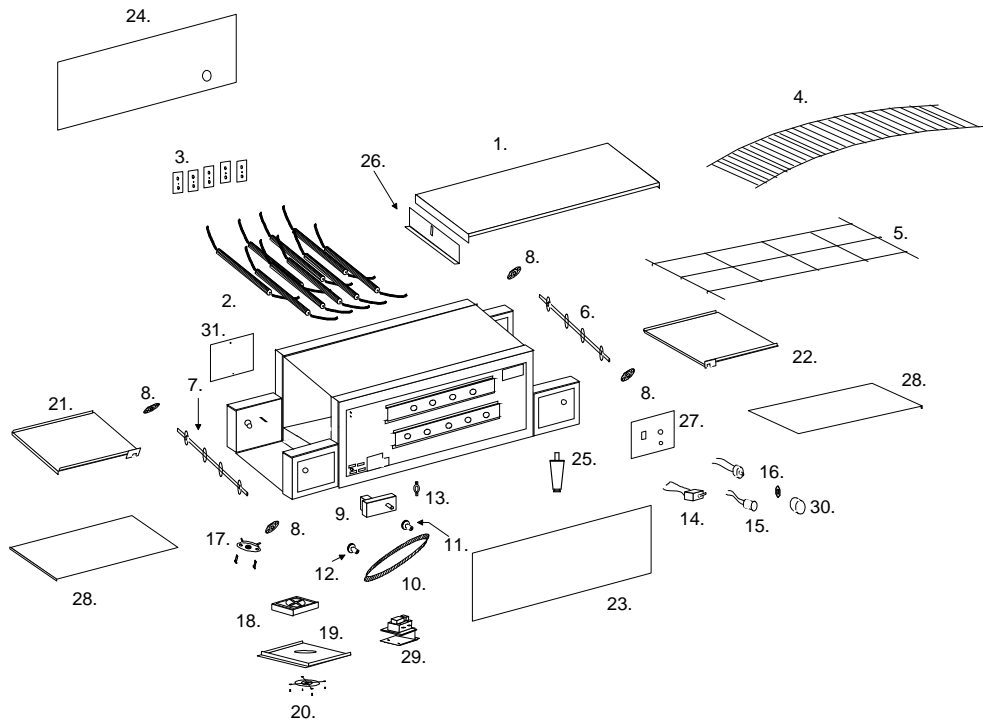

No.	PART No.	DESCRIPTION	Qty
1	GD-401168	Cover, Top	1
2	GD-197991	Heater Tube, Top, 208V	4
	GE-197988	Heater tube, Bottom 208V	5
2a.	GE-197992	Heater Tube, Top, 240V	4
	GE-197990	Heater Tube, Bottom 240V	5
3	GD-401232	Retainer, Heater Tube	5
4	GD-160008	Conveyor Belt	1
5	GD-100707	Belt Support Rack	1
6	GD-101251	Idler Shafts	1
7	GD-101252	Drive Shaft	1
8	GB-112262	Bearing	4
9	2U-200504	Drive Motor	1
10	GD-150023	Drive Chain	1
11	2P-200652	Driven Sprocket 3/8"	1
12	2P-200646	Drive sprocket 5/16"	1
13	2E-200574	Fan Switch	1
14	2E-200552	On/Off Switch/Rocker Swt	1
15	2J-200427	Pilot Light	1

No.	PART No.	DESCRIPTION	Qty
16	GB-118062	Speed control	1
17	2E-200566	Reset Switch	1
18	2U-200561	Fan Motor	1
19	GD-401636	Cover, Control Box	1
20	2R-200562	Grill, Fan Motor	1
21	GD-100403	Load Up Tray	1
22	GD-101403	Unload Tray	1
23	GD-416764	Side Panel	1
24	GD-401376	Side Panel, Cord	1
25	2R-200716	Leg, Metal, 2"	4
26	GD-401233	Shutter, Heat	2
27	GD-416162	Panel, Controls	1
28	GD-401227	Crumb Tray	2
29	2E-Z8966	Contactora 50 AMP 208/240V, HXM	1
	PS-Z14660	Contactora 40 AMP 208/240V, HXMA	1
30	SP-115360	Knob, Speed control	1
31	GD-401206	Cover, Extensions	3
	2U-200579	Motor Controller (not shown)	1