



**Star
Manufacturing
International Inc.**

10 Sunnen Drive
St. Louis, MO 63143

Phone: (314) 781-2777
FAX: (314) 781-3636

**Installation
and
Operating
Instructions**

2M-Y4587 REV. B 9/30/86

REV:6-15-01RDB

**COUNTER MODEL
POPCORN MACHINES
MODELS
39, 39D, 39S, 39SL**



GENERAL INSTALLATION DATA



CAUTION

This equipment is designed and sold for commercial use only by personnel trained and experienced in its operation and is not sold for consumer use in and around the home nor for use directly by the general public in food service locations. For equipment to be used by the general public, please contact the factory.

THOROUGHLY INSPECT YOUR MACHINE ON ARRIVAL

We do everything in our power to insure delivery of your machine in perfect condition. However there are instances in which the unit may be damaged in transit. In the event your unit is damaged in transit, have the transportation company make the necessary notations on your freight bill or delivery receipt. Immediately report this damage to the dealer from whom you purchased the machine. The dealer will advise proper handling instructions. If damage is not discovered until after delivery has been made, notify the transportation company immediately. However, in each instance, request an inspection report to cover whatever damage has occurred in transit.

INSTALLATION

Each machine has been properly wired and inspected at the Factory for operation on the Voltage and type of Current specified on the nameplate.



CAUTION

Do not connect to any other type of current or the machine will be seriously damaged.

We strongly recommend installation by a Licensed Electrician. The guarantee of this machine as covered by the Warranty Card does not apply if an improper installation has been made.

120 VOLT MACHINES

Machines with nameplate stamped 120V, are equipped for operation on 120 Volt, 2 wire, 60 Cycle AC single phase service and must be connected to a separate 15 Amp circuit with a 3 wire grounded, polarized receptacle.

GENERAL OPERATING INSTRUCTIONS



CAUTION

The motor air intake and exhaust holes located on top of the machine must be clear of any obstruction.

DO NOT COVER THESE AIR VENT HOLES as serious motor damage will result.

Check to insure the installation of the Corn Drawer before the Popping cycle is started.

With all switches in the "OFF" position, proceed in the following sequence to Pop Corn:

- 1.)** Turn "ON" the Corn Warming switch. This switch controls the Bottom heating element, the Top heating lamp and the Sign display lamps of the Sign Lighted models.
- 2.)** Turn "ON" the Kettle switch. This switch controls the Kettle heating element. The Red pilot light is provided to indicate when the Kettle switch is "ON". Allow six to seven minutes to pre-heat the Kettle. The Kettle heating element is thermostatically controlled. Thermostat adjustments should not be necessary as it has been preset at the factory for the correct popping temperature.
- 3.)** Turn "ON" the Agitator Motor switch. The Motor should always be running when there is corn in the Kettle. This will prevent scorching or burning of corn.

GENERAL OPERATING INSTRUCTIONS - continued

4.) A Corn and Seasoning measuring cup is supplied with your machine. Pour a level measuring cup of Oil (2 ounces) in Kettle. Add a leveled measuring cup of raw corn (6 ounces) and 1/2 Teaspoon of Popcorn Salt. Vary the amount of salt and oil to suit taste. If desired, salt may be added adfter the Corn is popped.

5.) When the Corn stops popping, dump the Kettle immediately by turning the handle clockwise approximately 90 degrees to release latch. Recharge as quickly as possible. Screen out unpopped kernels over the perforated section of the Corn pan.

6.) Turn the Kettle "OFF" when the desired amount of popping is completed.



WARNING

Do not leave the Kettle and Motor switch "ON" when the machine is not in use. Do not immerse the Kettle in water or allow water to come in contact with the Heating element.

Popping Corn in dry kettle is not recommended.

Do not connect machine to Direct Current, as this unit is designed to operate on Alternating Current only!

MAINTENANCE

Keep The Popping Unit Clean

After each popping period, wipe clean the Kettle inside and out while it is warm. This is important because if seasoning and salt are not thoroughly removed, a carbonized material will form. This condition not only lowers popping efficiency and causes excessive smoking, but could damage the unit. For retaining the high lustre on the stainless steel Kettle shell and lids, use a non-abrasive standard stainless steel cleaner when the Kettle is cold. Use a damp cloth and a warm mild soap solution to clean the glass and clear plastic surfaces.

To remove Kettle:

Turn "OFF" the Kettle motor switches. Disconnect the Twist Lock Cap at the end of the Kettle conduit, turn Kettle handle clockwise 90 degrees to unlatch the Kettle, hold the Kettle and pull out the hinge pin. The Kettle can now be removed from unit. Use asbestos gloves to remove a hot Kettle. **DO NOT PLACE THE KETTLE IN WATER**, as this will damage the electrical assembly.

To change Sign Display Lamps (on Sign Lighted Models):

Turn "OFF" all switches. Unscrew 2 sheet metal screws on the Rear side top (holding switch and pilot light panel) and 4 screws on the top. Cautiously take the top off. Cahnge bulb(s) and reassemble the top onto the frame. Tighten all six screws securely. **WARNING!** Use only inside Frosted Bulb. Wattage per label on the surface of the Top Liner. By Authorized Personnel Only.

MAINTENANCE and REPAIRS

Contact the Factory or one of its representatives or a local Service Company for Service or Maintenance required.

MATERIAL

DR. *JK* CK. DATE 5-22-84

LIMITS UNLESS OTHERWISE NOTED
FRACTIONS ± 1/64 DECIMALS ± .005

FINISH

STAR MANUFACTURING CO.
DIVISION OF PEABODY INTERNATIONAL CORPORATION
9325 OLIVE BOULEVARD ST. LOUIS MO. 63132

MODEL NO. 39E39D

PART NO.

TITLE **WIRE DIAGRAM**

CHANGES	LTR	DATE	CHANGE	DR
	A	10-11-84	ADDED TWIST LOCK DETAIL AND MOTOR GROUND	TH

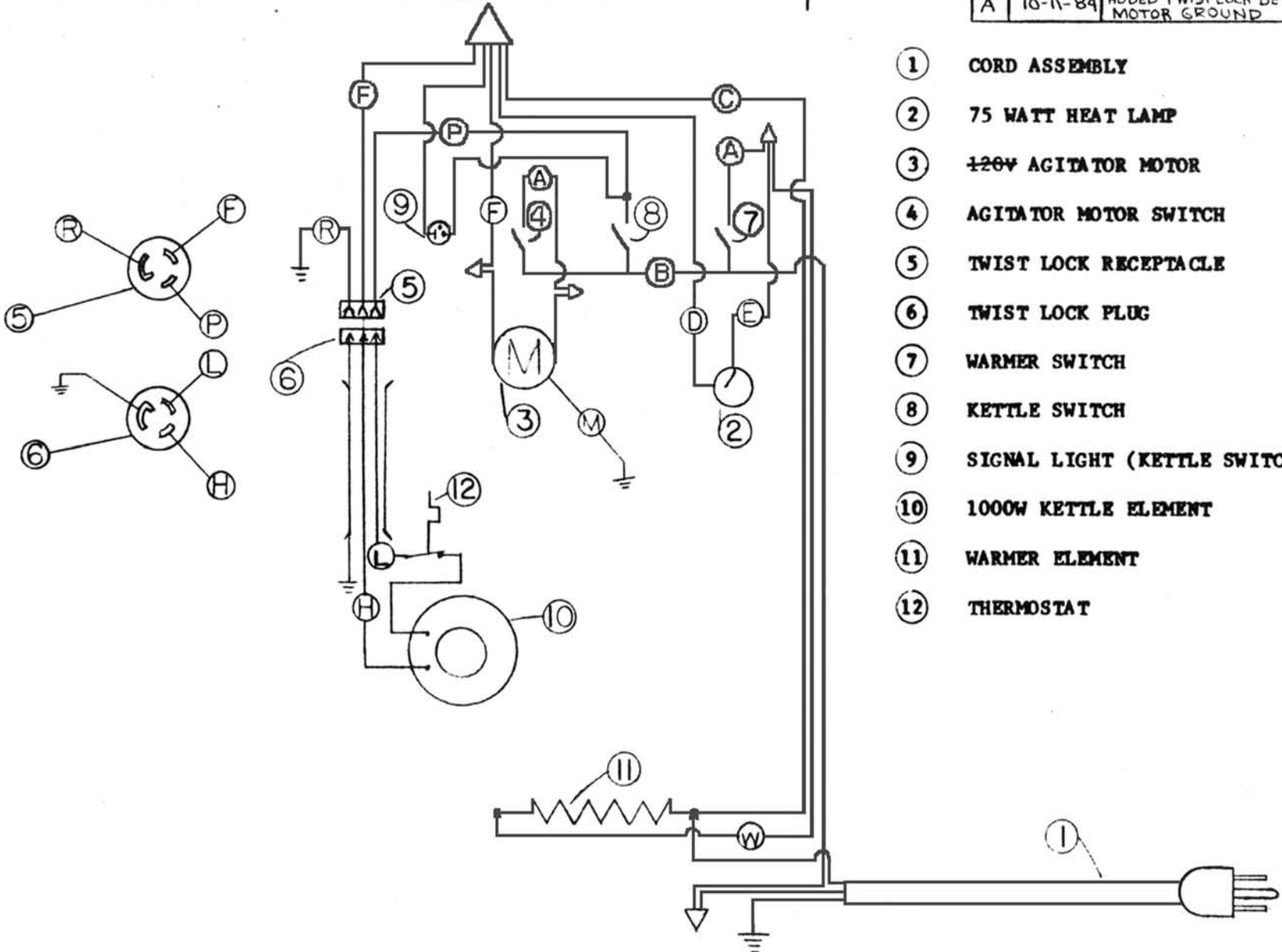

- ① CORD ASSEMBLY
- ② 75 WATT HEAT LAMP
- ③ ±26V AGITATOR MOTOR
- ④ AGITATOR MOTOR SWITCH
- ⑤ TWIST LOCK RECEPTACLE
- ⑥ TWIST LOCK PLUG
- ⑦ WARMER SWITCH
- ⑧ KETTLE SWITCH
- ⑨ SIGNAL LIGHT (KETTLE SWITCH ON)
- ⑩ 1000W KETTLE ELEMENT
- ⑪ WARMER ELEMENT
- ⑫ THERMOSTAT

MATERIAL
 DR. M.P. CK. DATE 9-21-88
 LIMITS UNLESS OTHERWISE NOTED
 FRACTIONS ± 1/64 DECIMALS ± .005

FINISH
 STAR MANUFACTURING CO.
 9325 OLIVE BOULEVARD ST. LOUIS MO. 63132

MODEL NO.
 39 SL

PART NO.

TITLE
 WIRE DIAGRAM

CHANGES	LTR	DATE	CHANGE	DR
	A	6-5-89	CHANGED TERMINALS ON MOTOR.	MD

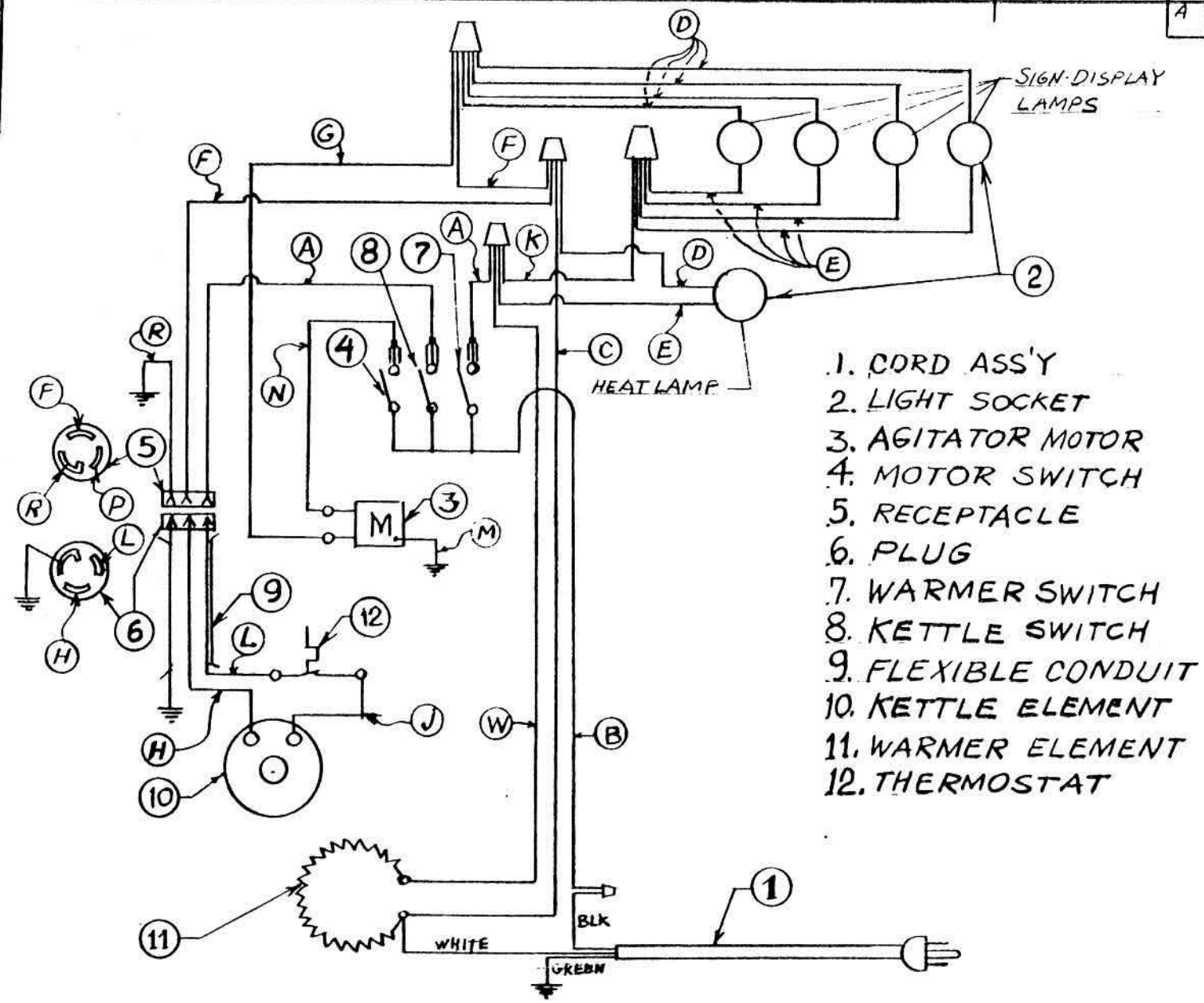

1. CORD ASS'Y
2. LIGHT SOCKET
3. AGITATOR MOTOR
4. MOTOR SWITCH
5. RECEPTACLE
6. PLUG
7. WARMER SWITCH
8. KETTLE SWITCH
9. FLEXIBLE CONDUIT
10. KETTLE ELEMENT
11. WARMER ELEMENT
12. THERMOSTAT

MATERIAL
 DR. M.P. CK. DATE 12-27-89
 LIMITS UNLESS OTHERWISE NOTED
 FRACTIONS ± 1/64 DECIMALS ± .005

FINISH
 STAR MANUFACTURING CO.
 9325 OLIVE BOULEVARD ST. LOUIS MO. 63132

MODEL NO. 39 SL 240V
 PART NO.
 TITLE WIRE DIAGRAM
 CHANGES LTR DATE CHANGE DR

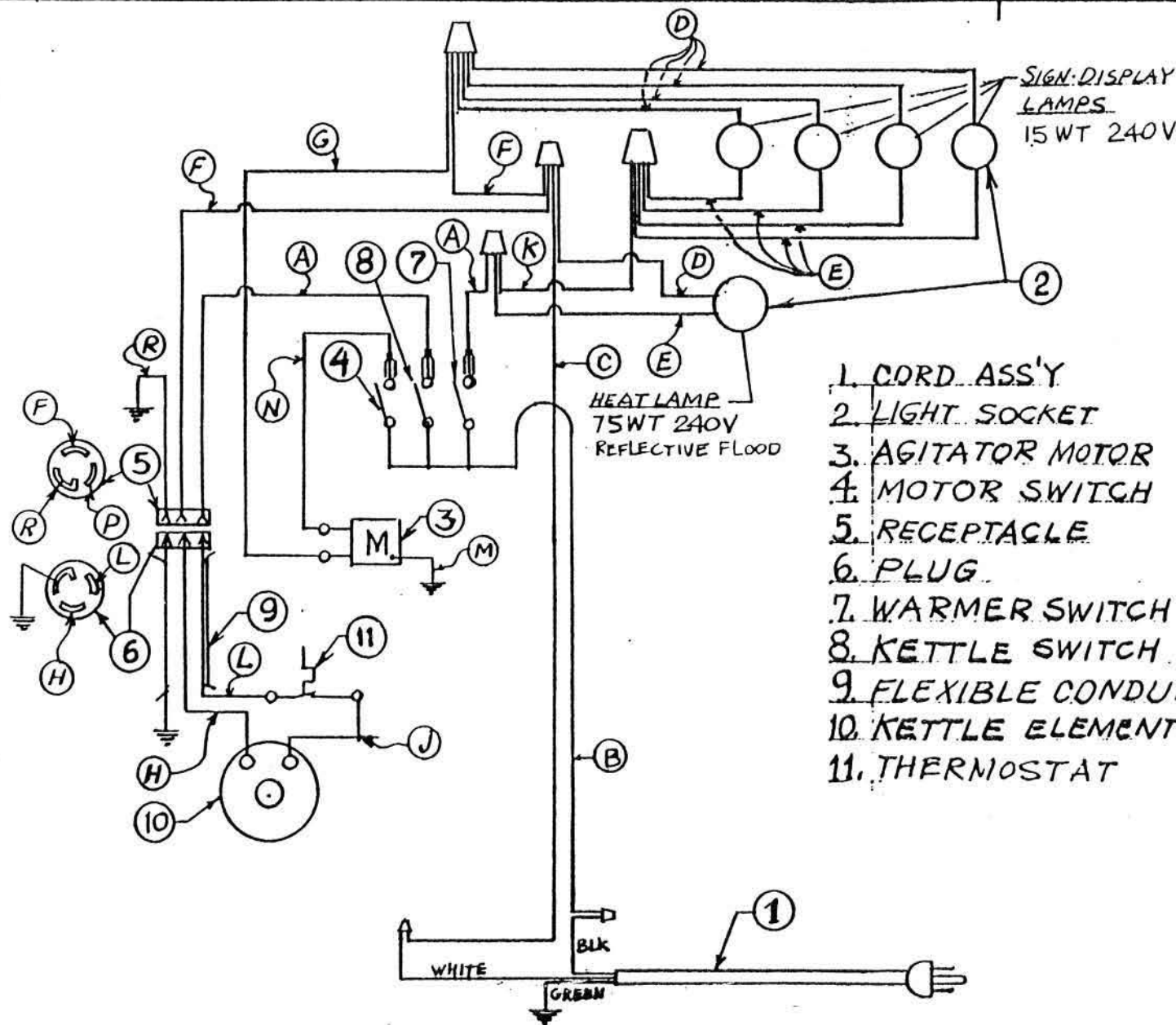

- 1. CORD ASS'Y
- 2. LIGHT SOCKET
- 3. AGITATOR MOTOR
- 4. MOTOR SWITCH
- 5. RECEPTACLE
- 6. PLUG
- 7. WARMER SWITCH
- 8. KETTLE SWITCH
- 9. FLEXIBLE CONDUIT
- 10. KETTLE ELEMENT
- 11. THERMOSTAT

HEAT LAMP
 75WT 240V
 REFLECTIVE FLOOD

SIGN DISPLAY
 LAMPS
 15 WT 240V

Hi-Temp Wire = 1N-E2052

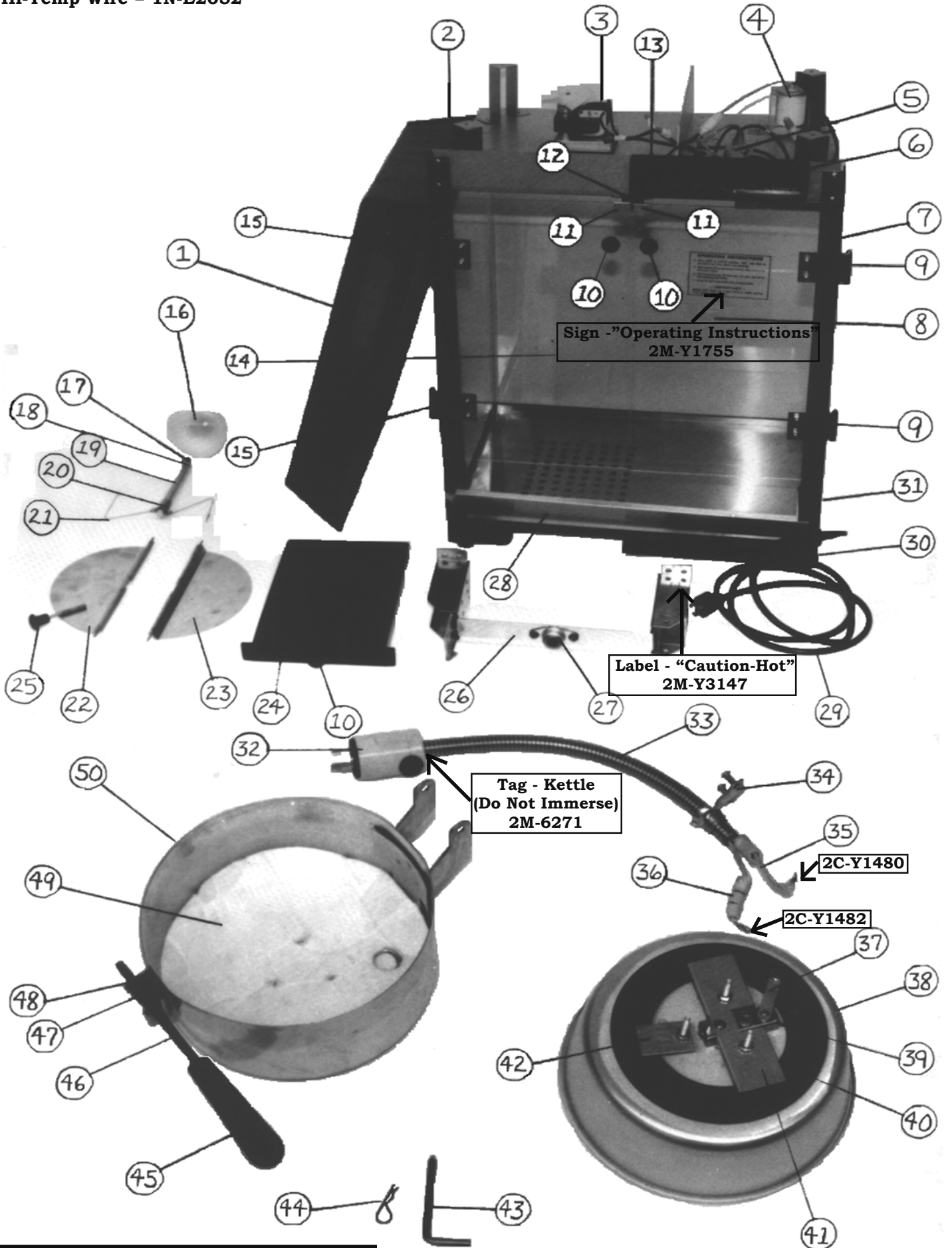

Temperature Range of Kettle = 500f to 550f

PARTS LIST

EFFECTIVE 10-13-06

MODEL 39 SERIES (#3955626 & BELOW)

Key Number	Part Number	Number Per Unit	Description
6 Oz. Machine Parts			
1	C3-39140	1	TOP ASSEMBLY COMPLETE (39) (not shown)
	C3-39132	1	TOP ASSEMBLY COMPLETE (39D) No Longer Available
	C3-39156	1	TOP ASSEMBLY COMPLETE (39SL) (not shown)
2	C3-Y7226	1	POPCORN SIGN (not shown)
	C3-Y4590	1	POPCORN SIGN (39D) (not shown)
3	2U-Y6914	1	MOTOR w/o FAN BLADE - 120V
	2U-Y6926	1	MOTOR w/o FAN BLADE - 240V
	2R-Y4810	1	FAN BLADE - MOTOR
4	2E-Y5921	1	LAMP RECEPTACLE
	C3-Y5920	1	LAMP CLIP (#3932007 & ABOVE)
5	2E-T1042	1	FEMALE TWIST-LOC RECEPTACLE w/o WIRES
6	2E-Y6144	3	SWITCH
7	PS-Y4556	1	BODY WRAP (#3945012 & BELOW) (20" high) (till 1991)
	C3-Y6710	1	BODY WRAP (#3945013 & ABOVE) (20-1/2" high) (since 1991) NLA
	2C-Y5136	4	CLIP - PUSH ON (not shown)
8-11	C3-39129	1	DOOR ASSEMBLY COMPLETE, LEFT
8	2Q-Y4547	1	DOOR w/o HARDWARE (15" x 8-3/4") (clear only)
9	C3-39131	2	DOOR HINGE ASSEMBLY, LEFT
10	2R-Z0872	2	DOOR KNOB (#8-32) (SCREW = 2C-1493, #8-32 x 3/8)
11	C3-Y2713	2	DOOR STRIKE
12	2C-9788	1	DOOR CATCH - MAGNET
13	2J-Y6689	1	PILOT LIGHT - 120V
	2J-Y6690	1	PILOT LIGHT - 240V
10,11 14,15	C3-39128	1	DOOR ASSEMBLY COMPLETE, RIGHT
14	C3-Y4547	1	DOOR w/o HARDWARE (15 x 8-3/4") (clear only)
15	C3-39130	2	DOOR HINGE ASSEMBLY, RIGHT
16	2S-Y4584	1	LAMP - 120V (75W)
	2S-1279	1	LAMP - DISPLAY (15W) (39SL)
			(#3935433 & BELOW)
17	2A-Y1555	1	UNIVERSAL
18	2A-5401	1	PIN - COTTER
19	2A-Y4582	1	AGITATOR SHAFT
20	C3-8318	1	AGITATOR COLLAR
21	2B-Y4581	2	AGITATOR BLADE

**IMPORTANT: WHEN ORDERING, SPECIFY VOLTAGE OR TYPE GAS DESIRED
INCLUDE MODEL AND SERIAL NUMBER**

PAGE 1 OF 4

Some items are included for illustrative purposes only and in certain instances may not be available.



Star Manufacturing International, Inc.

PARTS LIST

EFFECTIVE 10-13-06MODEL 39 SERIES (#3955626 & BELOW)

Key Number	Part Number	Number Per Unit	Description
6 Oz. Machine Parts			
17-21	C3-39133	1	AGITATOR ASSEMBLY COMPLETE (TO UPDATE/UPGRADE - #3935433 & BELOW)
17	2A-Y1555	1	UNIVERSAL
18	2A-5401	1	PIN - COTTER
19	2A-Y6208	1	AGITATOR SHAFT
20	2A-Y6207	1	AGITATOR COLLAR (1-3/4")
21	2B-Y6206	1	AGITATOR BLADE (6-1/2")
BELOW PARTS FOR #3945012 & BELOW			
22	C3-39102	±	KETTLE LID w/HANDLE, w/o KNOB No Longer Available
23	C3-39103	±	KETTLE LID No Longer Available
25	2R-1272	±	KNOB No Longer Available
26	C3-39118	1	KETTLE SUPPORT ASSEMBLY w/BEARING
27	2P-Y6231	1	BEARING ASSEMBLY
	C3-Y4572	1	SPRING - KETTLE LID
	C3-Y4575	1	SPRING - LATCH
	C3-Y4576	1	RETAINER - LATCH SPRING
	C3-Y4573	1	RETAINER - LID SPRING
BELOW PARTS FOR #3945013 & ABOVE			
	C3-39214	1	KETTLE LID (one piece)
	C3-Y7230	1	CUP - MAGNET
	2R-Y7229	1	MAGNET
	2A-Y6915	1	GUIDE - LID
	C3-39168	1	KETTLE LATCH ASSEMBLY
24	C3-Y4544	1	CORN DRAWER w/o KNOB
10	2R-Z0872	1	KNOB
28	C3-39105	1	FRONT LOWER DOOR ASSEMBLY (stainless steel) (18-1/4" L x 4-1/2" H, flange to flange)
29	C3-39111	1	LEAD IN CORD - 120V
	C3-39123	1	LEAD IN CORD - 240V
30	2I-H7685	4	FOOT
31	2N-Y4306	1	WARMER ELEMENT - 120V (not shown)
51	2L-Y4639	1	OIL CUP (1/4 cup) (not shown)
52	2L-Y4640	1	CORN CUP (3/4 cup) (not shown)
53	2L-Y4916	1	CORN SCOOP (RED PLASTIC) (not shown)

**IMPORTANT: WHEN ORDERING, SPECIFY VOLTAGE OR TYPE GAS DESIRED
INCLUDE MODEL AND SERIAL NUMBER**

PAGE 2 OF 4

Some items are included for illustrative purposes only and in certain instances may not be available.



Star Manufacturing International, Inc.

PARTS LIST

EFFECTIVE 10-13-06

MODEL 39 SERIES (#3955626 & BELOW)

Key Number	Part Number	Number Per Unit	Description
6 Oz. Kettle Assembly			
32-50	C3-39144	1	KETTLE ASSEMBLY COMPLETE (spun aluminum casting) N/A
32-36	C3-39126	1	KETTLE CONDUIT COMPLETE (w/wires & twist-loc plug)
32	2P-8354	1	MALE TWIST-LOC PLUG
33	C3-8355	1	CONDUIT (14")
	C3-Y3045	1	GROUND STRAP
34	2E-1177	1	SQUEEZE CONNECTOR
35	C3-39125	1	KETTLE LEAD WIRE ASSEMBLY (2 wire set w/terminals)
36	2I-5062	6	INSULATOR BEAD
	2K-3831	1	BUSHING (for conduit)
37	C3-39202	1	WIRE ASSEMBLY / JUMPER
38	C3-39225	1	KETTLE CASTING ONLY (cold-rolled steel w/nickel plating)
	2C-Y5137	3	STUD (10-24 x 1-5/8")
	2C-Y7271	3	STUD (10-24 x 1")
	2C-2559	6	ACORN NUT
39	2T-6213	1	THERMOSTAT
40	2N-Y5334	1	KETTLE ELEMENT - 120V (1000W) (vendor # A65)
	2N-Y4922	1	KETTLE ELEMENT - 240V (1000W)
41,42	C3-Y6611	1	ELEMENT BRACKET (NOT AS PICTURED)
	2C-2560	3	NUTS - ELEMENT BRACKET
43	C3-Y4595	1	KETTLE HINGE PIN
44	2A-Y6694	1	CLIP - HAIR PIN
45-48	C3-39127	1	KETTLE HANDLE ASSEMBLY COMPLETE
45	2R-Y6762	1	KETTLE HANDLE
46	C3-Y4561	1	KETTLE ROD HANDLE
47	2P-Y4564	1	KETTLE HANDLE SPRING
48	C3-Y5378	1	CAM
49	C3-Y4928	2	KETTLE INSULATION
50	C3-39171	1	KETTLE SHELL ASSEMBLY
<i>NEW STYLE KETTLE ASSEMBLY > NEXT PAGE</i>			

**IMPORTANT: WHEN ORDERING, SPECIFY VOLTAGE OR TYPE GAS DESIRED
INCLUDE MODEL AND SERIAL NUMBER**

PAGE **3** OF **4**

Some items are included for illustrative purposes only and in certain instances may not be available.



Star Manufacturing International, Inc.

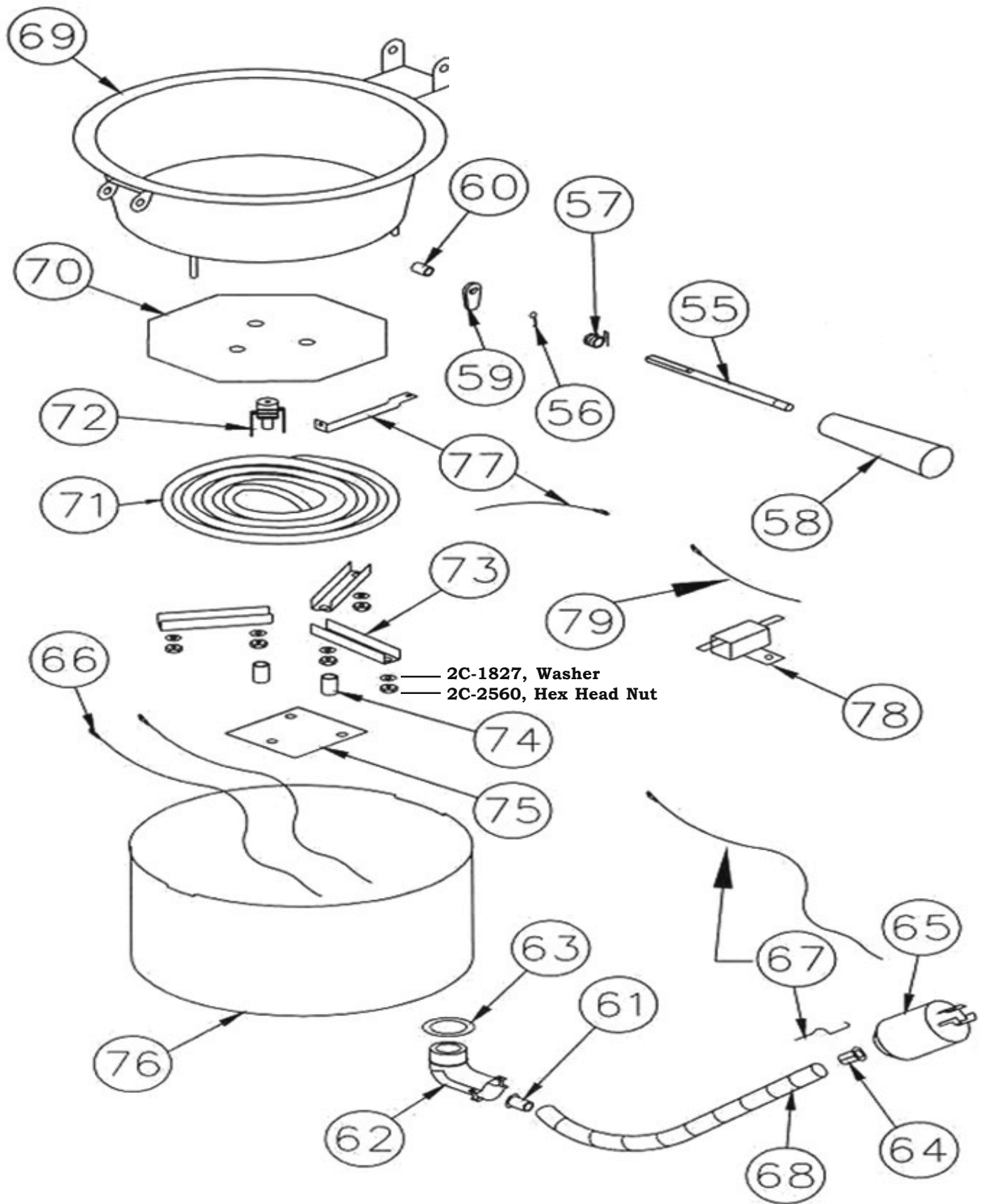

C3-39209

PARTS LIST

EFFECTIVE 10-13-06

MODEL 39 SERIES

Key Number	Part Number	Number Per Unit	Description
New Style - 6 Oz. Kettle Assembly			
55-79	C3-39209	1	KETTLE ASSEMBLY - 120V
	C3-39219	1	KETTLE ASSEMBLY - 240V
55-60	PS-39216	1	KETTLE HANDLE ASSEMBLY COMPLETE
55	2A-Y6140	1	ROD - HANDLE
56	2B-Y6139	1	CLIP - HANDLE
57	2P-Y6141	1	SPRING - HANDLE
58	2R-Y7381	1	HANDLE - KETTLE
59	C3-Y5378	1	CAM
60	2A-Y6142	1	SLEEVE - HANDLE
61-68	PS-39217	1	KETTLE CONDUIT COMPLETE (w/wires & twist-loc plug)
61	2A-Y6627	1	BUSHING
62	2E-1177	1	SQUEEZE CONNECTOR
63	2E-Y4967	1	WASHER
64	2K-1057	1	BUSHING, ANTI-SHORT
65	2P-8354	1	MALE TWIST-LOC PLUG
66	C3-39125	1	LEAD WIRE ASSEMBLY (2 wire set w/terminals)
	2C-9617	2	WIRE TERMINAL
67	C3-Y3045	1	GROUND STRAP
68	C3-Y6634	1	CONDUIT
69	C3-39208-PS	1	KETTLE ASSEMBLY - LINER (cold-rolled steel w/nickel plating)
70	C3-39179	1	PLATE - HEAT SINK ASSEMBLY
71	2N-Y7413	1	ELEMENT - 120V (1000W)
	2N-Y7414	1	ELEMENT - 240V (1000W)
72	2T-Y7422	1	THERMOSTAT
73	C3-Y7361	3	CHANNEL - ELEMENT HOLDER
74	2A-Y7482	3	SPACER
75	C3-Y7693	1	INSULATION PAD
76	C3-Y7360	1	KETTLE SHELL
77	C3-Y7362	1	LUG / BUSS BAR
78	C3-Y9419	1	HIGH LIMIT THERMOSTAT (230CE only)
79	C3-39233	1	WIRE ASSEMBLY (230CE only)

**IMPORTANT: WHEN ORDERING, SPECIFY VOLTAGE OR TYPE GAS DESIRED
INCLUDE MODEL AND SERIAL NUMBER**

PAGE **4** OF **4**

Some items are included for illustrative purposes only and in certain instances may not be available.



Star Manufacturing International, Inc.