



**OPERATOR'S MANUAL  
HOLMAN CONVEYOR OVENS  
MODEL 414HXM**

**FOR SERVICE INFORMATION  
U.S. AND CANADA CALL: 314-678-6303  
24 HOURS/DAY 7 DAYS/WEEK**

**TABLE OF CONTENTS**

UNCRATING AND INSPECTION	PAGE 1
ASSEMBLY AND INSTALLATION	PAGE 1, 2, 3
STACKING INSTRUCTIONS	PAGE 3
OPERATION	PAGE 4
CLEANING PROCEDURES	PAGE 4, 5
TROUBLESHOOTING GUIDE	PAGE 5, 6, 7
MAINTENANCE PROCEDURES	PAGE 8, 9, 10
PARTS LIST/EXPLODED VIEW	PAGE 13

**DRAWINGS**

LOAD AND UNLOAD TRAYS	PAGE 4
REMOVING THE CONVEYOR BELT	PAGE 4
HEAT REFLECTOR/CRUMB TRAYS	PAGE 6
HEATER TUBE & FAN MOTOR INSTALLATION	PAGE 8
DRIVE SYSTEM	PAGE 9
MOTOR CONTROLLER	PAGE 11
WIRING DIAGRAM	PAGE 14, 15

**OPERATOR'S MANUAL  
HOLMAN CONVEYOR OVENS  
MODEL 414HXM**

**UNCRATING AND INSPECTION**

Unpack unit and components from container. Remove all visible packing material, inspect unit for damage. If damage is discovered, file a claim immediately with the carrier that handled the shipment.

The following should be included in the container:

- A. 1ea. baking oven with heaters, tunnel extender, power supply lead and conveyor belt in place.  
**(NOTE): Remove heating element-shipping supports.**
- B. 1ea. Stainless Steel Unload Tray and 1ea. Stainless Steel Load Up Tray.

**ASSEMBLY AND INSTALLATION**

- A. Attach legs by screwing into weld nuts, as shown

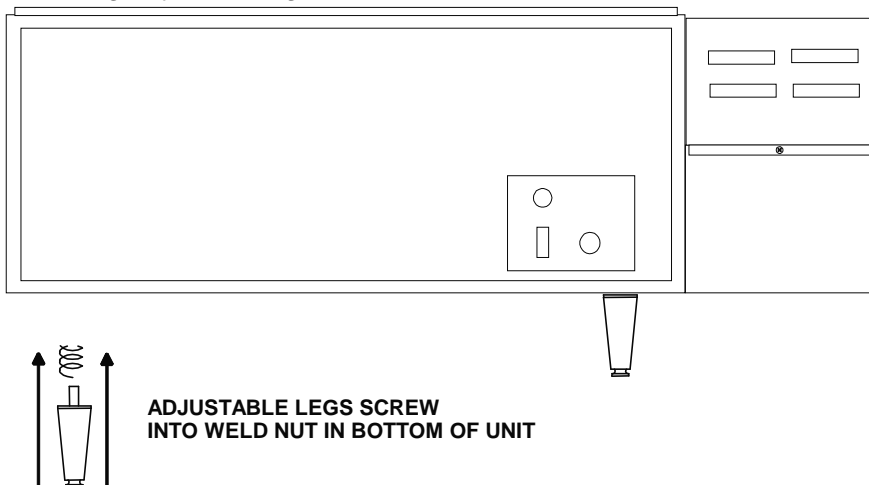

- B. Anti Skid pads are available at no charge and may be adhered to the foot section of each leg to prevent sliding. Call 314-678-6303 for details.

**CAUTION:** the National Sanitation Foundation does not approve use of these pads.

- C. Install unit in its operating position. The load & unload ends must be at least 6" from any vertical combustible surfaces. Allow sufficient space for operating personnel.

- 1) Your model 414HXM conveyor oven is supplied with a six-foot power supply cord. Have an electrician connect input power to the unit in accordance with local electrical codes.

ASSEMBLY AND INSTALLATION CONT. ON PAGE 2

**OPERATOR'S MANUAL  
HOLMAN CONVEYOR OVENS  
MODEL 414HXM**

**ASSEMBLY AND INSTALLATION (CONT)**

**WARNING:** MAKE SURE ALL INPUT POWER IS OFF BEFORE INSTALLING/REMOVING ANY PARTS.

**WARNING:** BEFORE INSTALLING UNIT(S), HAVE YOUR ELECTRICIAN CHECK WITH LOCAL POWER COMPANY TO DETERMINE ACTUAL VOLTAGE AT JOB SITE.

**WARNING:** BE ABSOLUTELY SURE THE GROUND (EARTH) CONNECTION FOR THE RECEPTACLE IS PROPERLY WIRED. NEVER CONNECT UNIT TO POWER WITHOUT PROPER GROUND CONNECTIONS. **IMPROPER GROUND MAY RESULT IN SEVERE INJURY OR FATALITY.**

- D. Before applying input power to the unit(s) check heating elements for breakage, do not apply power to the unit(s) if a broken tube is found. If no broken tubes are found apply input power by turning the master On/Off toggle to the **ON** position. Turn conveyor belt speed control to the maximum setting and check all heater tubes and conveyor for proper operation.
- E. Allow approximately 5 to 8 minutes for the fan cooling system to come on, check the air intake area as noted below and be sure that there is a sufficient flow of air into the control box.

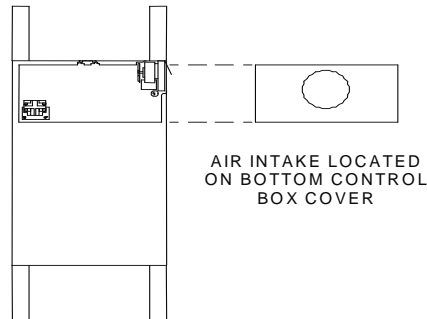

- F. If all heaters and conveyor system are operating properly, turn the master On/Off switch to the **OFF** position and allow unit to cool. The fan will continue to circulate cool air through out the unit until the internal temperatures have been decreased.

If a problem is discovered during start up procedures, immediately turn the Master On/Off switch to the **OFF** position and call the **Holman Cooking Equipment Factory Service Team at 314-678-6303.**

- G. The load up and unload trays have a key-hole slot on the end of the tray that will slide over the two screw heads on the end of the oven as shown below:

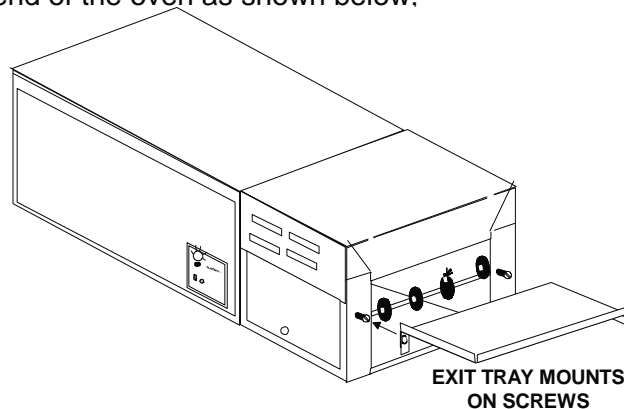

ASSEMBLY AND INSTALLATION CONT. ON PAGE 3

**OPERATOR'S MANUAL  
HOLMAN CONVEYOR OVENS  
MODEL 414HXM**

**ASSEMBLY AND INSTALLATION (CONT.)**

H. Stacking Instructions

**When stacking two Holman 414HXM ovens, a stacking spacer with external air duct must be used to prevent overheating of the control box in the top oven.**

- 1) If cart is to be used with units, place bottom unit on cart and align leg holes of unit to holes in top portion of cart. Insert 3/8" bolts through cart and into leg holes to secure bottom unit to cart as shown below.
- 2) Place stacking spacer on top of bottom oven with **internal** air duct facing up and toward the rear of the oven.
- 3) Mount **external** air duct on stacking spacer as shown below. External air duct must be installed for cooling system of top unit to function properly.
- 4) Install cap screws (4ea.) into leg holes on top oven.
- 5) Place top oven on stacking spacer. Cap screws will set into cut outs in top of stacking spacer to lock unit into position.

**(NOTE) Air intake of top unit must fit over the internal air duct of stacking spacer to allow airflow into the control box of the top oven. For stacking spacer to work properly, both ovens must have the same belt travel direction.**

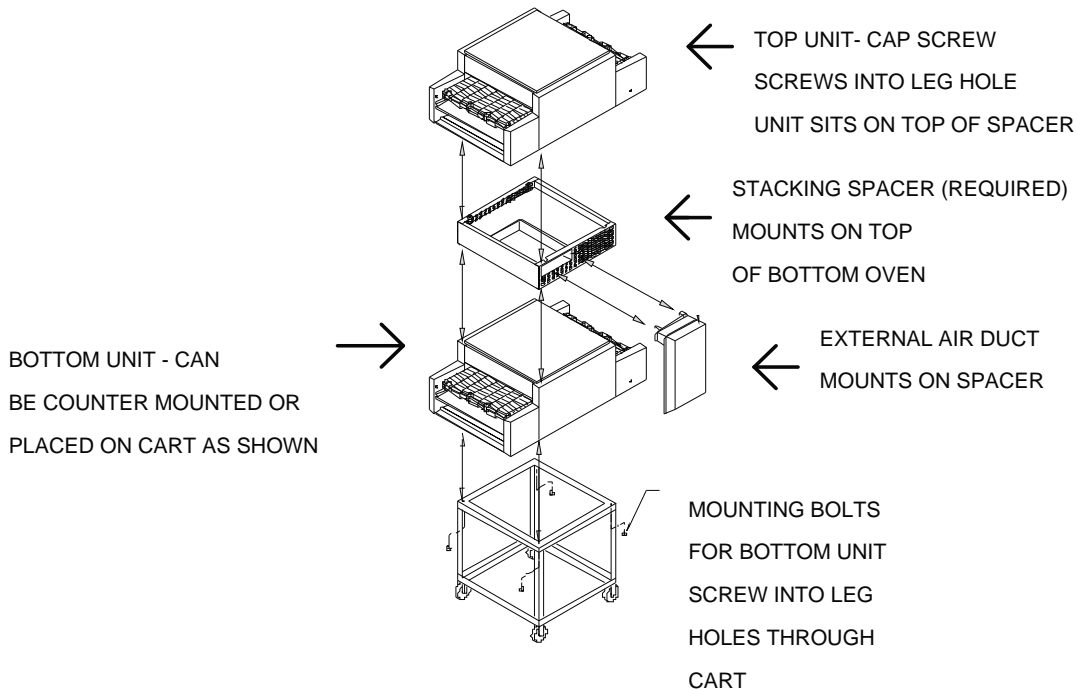

**OPERATOR'S MANUAL  
HOLMAN CONVEYOR OVENS  
MODEL 414HXM**

**OPERATION**

- A. Switch Master On/Off switch to the ON position and turn Variable Speed Control to fastest time setting.
- B. Allow 10 to 15 minutes for unit(s) to warm up.
- C. Adjust conveyor belt speed to the desired pass time and place product on conveyor belt.

**CLEANING PROCEDURES**

Preventive maintenance for your Holman oven consists of the following recommended cleaning procedures to keep your oven in its top operating condition.

**WARNING: HIGH VOLTAGES ARE PRESENT IN THESE UNITS. DISCONNECT UNIT FROM POWER SUPPLY BEFORE SERVICING OR CLEANING UNIT.**

- A. Remove Load and Unload Trays (daily) as shown and wash with hot soapy water.

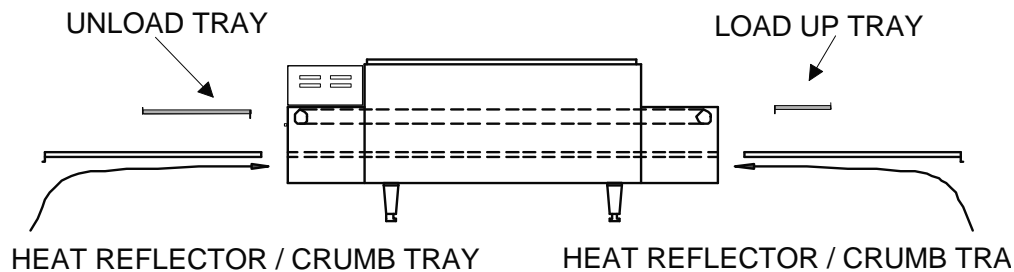

- B. Remove the Crumb Trays from both load and unload ends of the oven (daily) as shown above **(DO NOT CLEAN WITH CAUSTIC CLEANERS)**.
- C. For lightly soiled conveyor surfaces a damp cloth or scotch pad can be used without removing the conveyor belt.
- D. For heavily soiled conveyor surfaces disconnect the quick clips, remove the conveyor and soak in hot soapy water overnight.

**NOTE: LUBRICATION OF DRIVE CHAIN WITH GRAPHITE BASED LUBRICANT IS REQUIRED AS PERIODIC MAINTENANCE. CALL THE HOLMAN FACTORY SERVICE TEAM FOR DETAILS.**

CLEANING PROCEDURES CONT. PAGE 5

**OPERATOR'S MANUAL  
HOLMAN CONVEYOR OVENS  
MODEL 414HXM**

**CLEANING PROCEDURES CONT.**

- E. **Check Air Intake area (daily) for dust and grease.** To clean, remove the Control Box Cover and wipe with a dry cloth. Do not spray cleaning fluids into the air intake as this may result in component failure.
- F. Re-assemble unit and check to be sure it is operating properly. Contact the **Holman Cooking Equipment Factory Service Team at 314-678-6303** if assistance is required.

**NOTE: Refer to the preventative maintenance manual for further cleaning instructions.**

**TROUBLESHOOTING GUIDE**

A. UNIT WILL NOT HEAT, CONVEYOR BELT WILL NOT TURN.

- 1) Be sure main Circuit Breaker is switched to the ON position and there is power at the outlet.
- 2) Check to see that the unit is connected to power and Master On/Off is switched to the ON position.
- 3) Be sure HEAT LIMIT SWITCH is pushed in (see below).

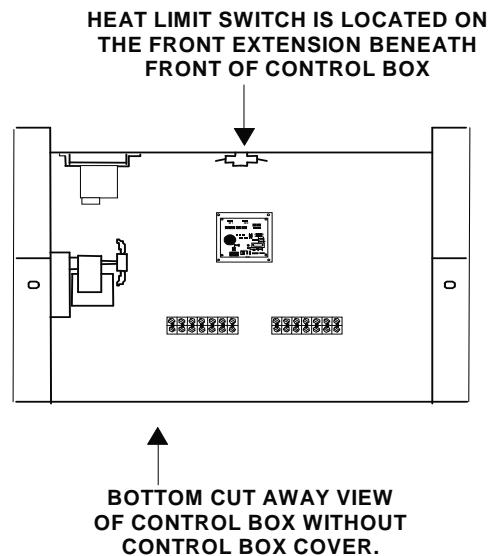

B. UNIT WILL NOT HEAT, CONVEYOR TURNS.

- 1) Check to see if the Master On/Off Switch is in the ON position.
- 2) Press Heat Limit Switch, located on the front section of the control box as shown above. If this reactivates the Heater Tubes, see section C page 6.
- 3) Contact the Holman Cooking Equipment Factory Service Team if assistance is required.

TRUBLESHOOTING GUIDE CONT. ON PAGE 6

**OPERATOR'S MANUAL  
HOLMAN CONVEYOR OVENS  
MODEL 414HXM**

**TROUBLESHOOTING GUIDE CONT.**

**C. HEAT LIMIT SWITCH**

Your Holman Conveyor Oven is equipped with an automatically activated HEAT LIMIT SWITCH that interrupts the heater tube connections if the air temperature in the control box exceeds 190° F (88° C). This Limit Switch can be reset manually by pushing the button in the center of the switch that is located as shown.

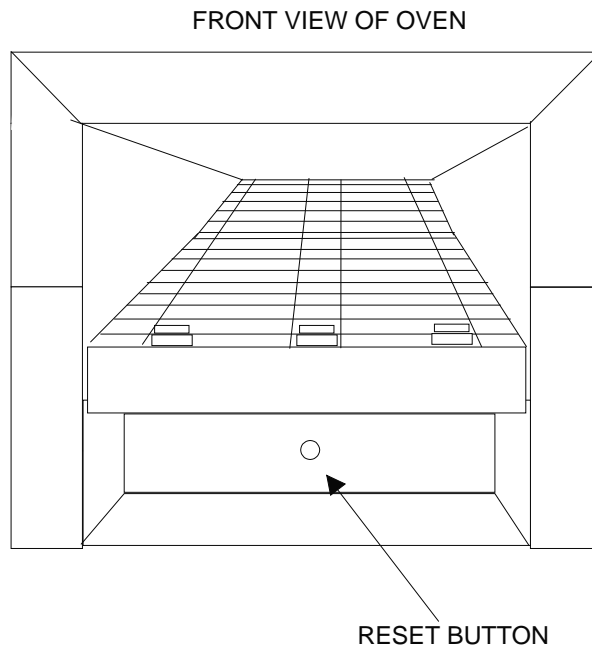

THE HEAT LIMIT SWITCH CAN BE ACTIVATED IF THERE IS NOT A PROPER AMOUNT OF AIR FLOW BEING GENERATED BY THE COOLING FAN. IF THIS OCCURS:

**1) DISCONNECT UNIT FROM POWER SOURCE.**

- 2) Check to see if air intake area (openings in bottom center of Control Box) is free of dust, grease or other obstructions.
- 3) Check to see if Crumb Trays (heat reflectors) are in place.

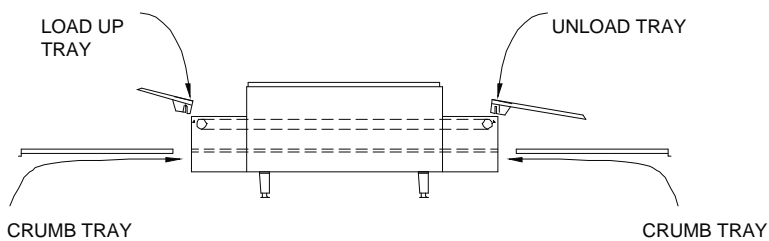

NEVER OPERATE UNIT WITHOUT CRUMB TRAYS IN POSITION AS THIS CAUSES OVERHEATING IN THE CONTROL BOX.

TROUBLESHOOTING GUIDE CONT. ON PAGE 7

**OPERATOR'S MANUAL  
HOLMAN CONVEYOR OVENS  
MODEL 414HXM**

**TROUBLESHOOTING GUIDE CONT.**

D. CONVEYOR WILL NOT TURN, UNIT HEATS PROPERLY.

**1) DISCONNECT UNIT FROM POWER SOURCE.**

2) Check to see if there are obstructions in the conveyor system that may cause a jam.

3) Remove Control Box Cover (as shown on page 8) and spin the Drive Motor Shaft (as shown on page 9). Recheck to see if the Conveyor now works.

IF CONVEYOR STILL DOES NOT TURN;

4) Remove power supply Side Panel and Drive Motor Sprocket (see below). Manually move Conveyor Belt to check for mechanical binding. If Conveyor moves freely, call the **Holman Cooking Equipment Factory Service Team at 314-678-6303** as Drive Motor and/or Variable Speed Control Unit may have to be replaced (refer to page 9 for instructions on replacing drive motor).

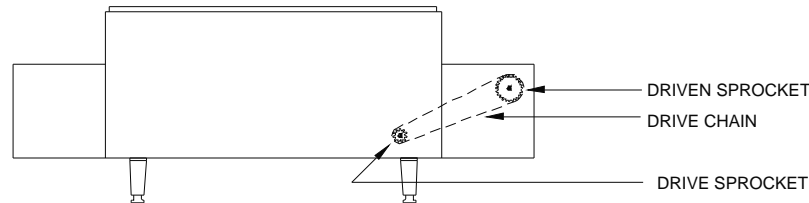

E. CONVEYOR TURNS AT ONE SPEED REGARDLESS OF SPEED CONTROL SETTING.

1) Call the **Holman Cooking Equipment Factory Service Team at 314-678-6303**, as Variable Speed Control Unit may have to be replaced. (Refer to page 10 for instructions on replacing the Variable Speed Control).

F. COOLING FAN DOES NOT START.

1) Remove Control Box Cover and check Fan Blade for obstructions.

2) Check Fan Motor Cord for secure connection.

3) Call the Holman Factory Service Team, as the Fan Switch and/or Fan Motor may have to be replaced.



**OPERATOR'S MANUAL  
HOLMAN CONVEYOR OVENS  
MODEL 414HXM**

**MAINTENANCE PROCEDURES**

**A. REPLACING HEATER TUBES (see below)**

**1) DISCONNECT UNIT FROM POWER SOURCE.**

- 2) Remove left and right side panels by removing the Philips head screws in each panel. Pull the top of each panel out slightly and lift up.
- 3) Disconnect heater tube wires that require replacement from terminal block connections.
- 4) Loosen screw holding Heater Tube Retainer in place (retainers are located on power supply side of unit). Slide the retainer to the side and tighten screw.
- 5) GENTLY, pull defective Heater Tube out of unit.
- 6) GENTLY, place new Heater Tube into unit.
- 7) Loosen retainer screw and slide retainer back into original position. Make sure the ends of the quartz heater tubes are free to move slightly.
- 8) Reconnect heater wires to terminal block connections.
- 9) Replace side panels and test unit for proper operation

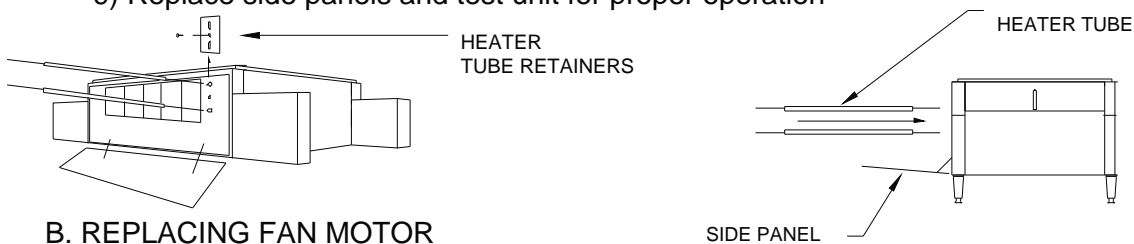

**B. REPLACING FAN MOTOR**

**1) DISCONNECT UNIT FROM POWER SOURCE.**

- 2) Turn unit over and lay on top cover with the legs pointing at the ceiling.
- 3) Remove control box cover with Fan Motor.
- 4) Unplug power supply cord from Fan Motor.
- 5) Remove (4) screws that hold Fan Motor and grill to cover.
- 6) Put replacement motor and grill in place and secure to the control box cover with screws.

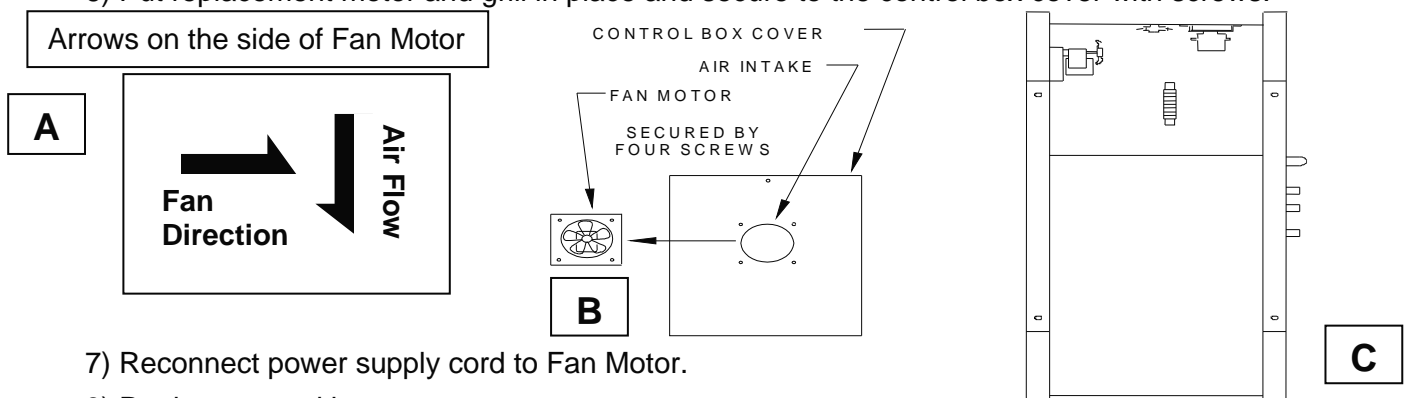

- 7) Reconnect power supply cord to Fan Motor.
- 8) Replace control box cover.

**OPERATOR'S MANUAL  
HOLMAN CONVEYOR OVENS  
MODEL 414HXM**

**MAINTENANCE PROCEDURES CONT.**

**C. REPLACING BELT DRIVE MOTOR**

**1) DISCONNECT UNIT FROM POWER SOURCE.**

- 2) Remove power supply side panel and control box cover as described in section B of previous procedure.
- 3) Remove sprocket from motor shaft by loosening the Allen screw on the sprocket collar.
- 4) Disconnect the Drive Motor leads to the internal wiring. Motors are rated 208 Volts or 240 Volts, note which color leads are being used for these connections and which lead is capped with white tape. The new Drive Motor should use the same arrangement.
- 5) Remove the four screws that hold the Drive Motor in place.
- 6) Put the new motor in place and loosely attach with the four screws removed from step 5.
- 7) Replace the Sprocket onto the motor shaft, and then replace the Drive Chain onto the sprockets.

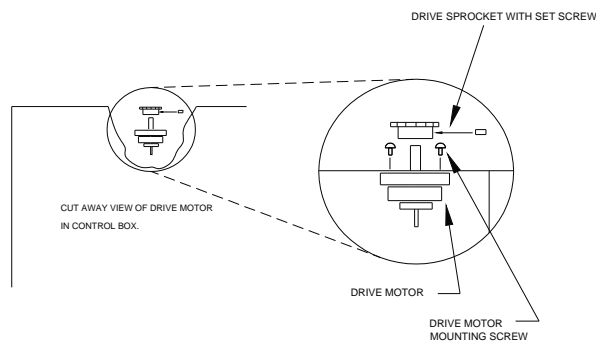

- 8) Slide the Drive Motor until the Drive Chain has about 1/8" slack when lightly pushed at the center of its top open run. Tighten the Drive Motor screws.

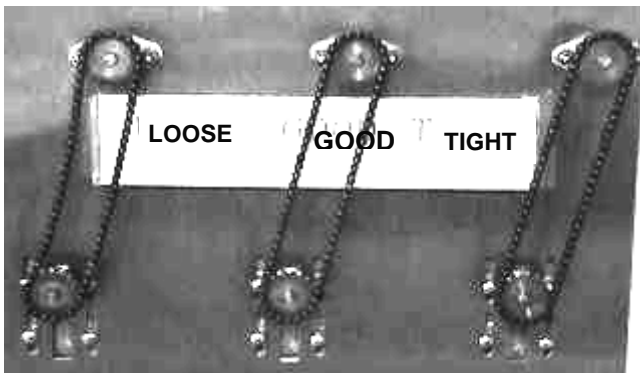

- 9) Rewire the Drive Motor as described in step 4 above. Replace the panels and test for proper operation.

**OPERATOR'S MANUAL  
HOLMAN CONVEYOR OVENS  
MODEL 414HXM**

**MAINTENANCE PROCEDURES CONT.**

D. REPLACING THE VARIABLE SPEED CONTROL (see below)

**1) DISCONNECT UNIT FROM POWER SOURCE.**

- 2) Remove Philips head screws holding control side panel in place and remove side panel.
- 3) Remove the Variable Speed Control knob and the lock nut holding the Variable Speed Control in place.
- 4) Wires from Variable Speed Control go in to terminals block located on side of chassis. Remove wires for old Variable Speed Control and insert wires for new Variable Speed Control in same positions as shown on wiring diagram on page 13.
- 5) When replacing the Variable Speed Control in the side panel, make sure to reinstall the fish paper between the switch and the side panel and reposition the anti-rotation pin in the anti-rotation slot on the panel. The wires for the speed control switch must be inside the protective sleeve that came with the replacement switch.
- 6) Replace lock nut and control knob

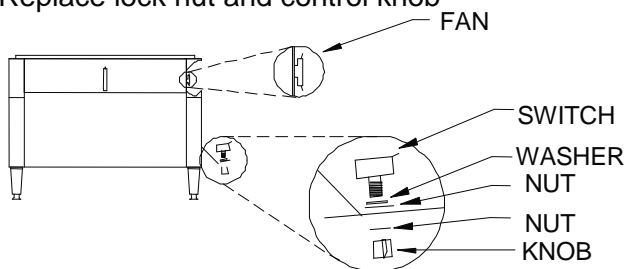

D. REPLACING THE VARIABLE SPEED MOTOR CONTROL (see below)

**1) DISCONNECT UNIT FROM POWER SOURCE.**

- 2) Turn unit over and lay on top cover with the legs pointing at the ceiling.
- 3) Remove Philips head screws holding control box cover in place. Lift and slide forward to remove cover.
- 4) Locate the motor controller mounted in the top center of the control box.
- 5) Wires from Variable Speed Control go in to terminals located on the controller. **Note the location of the colored leads** and remove wires for Variable Speed Control.
- 6) Disconnect the wires from terminals marked L1, L2/N, U and V (note which wires go to each terminal).
- 7) Remove Philips head screws (4ea.) holding controller in place.
- 8) Mount replacement control in the same manner as the old control.
- 9) Reconnect wires removed from old control (refer to wiring diagrams).
- 10) Replace control box cover, place unit on legs and connect to power supply. Test for proper operation.
- 11) Call the **Holman Cooking Equipment Factory Service Team at 314-678-6303**. if assistance is required.

**OPERATOR'S MANUAL  
HOLMAN CONVEYOR OVENS  
MODEL 414HXM**

<b>HEATER TUBE PART LIST</b>		
<b>PART NUMBER</b>	<b>DESCRIPTION</b>	<b>QTY.</b>
GE-197988	HEATER TUBE QUARTZ, TOP, <b>208V, 3 PHASE</b>	6
GE-198084	HEATER TUBE QUARTZ, TOP, <b>208V, 1 PHASE</b>	6
2N-209195	HEATER TUBE METAL, BOTTOM, <b>208V, ALL</b>	6
2N-209204	HEATER TUBE QUARTS, BOTTOM, <b>220V</b>	6
ZZ-197884	HEATER TUBE METAL, TOP, <b>220V</b>	6
GE-197990	HEATER TUBE QUARTZ, TOP, <b>240V, 3 PHASE</b>	6
GE-198085	HEATER TUBE QUARTZ, TOP, <b>240V, 1 PHASE</b>	6
2N-209196	HEATER TUBE METAL, BOTTOM, <b>240V, ALL</b>	6

<b>PART No.</b>	<b>DESCRIPTION</b>	<b>Qty.</b>	<b>PART No.</b>	<b>DESCRIPTION</b>	<b>Qty.</b>
GE-402163	Cover, Top	1	2E-118066	Speed Control	1
GE-402629	Retainer, Heater tube	*	2J-200427	Pilot Light	1
GD-160008	Conveyor Belt	2	2E-200552	Rocker Switch	1
GE-100982	Tunnel Extender	1	2R-200761	Control Knob	1
GD-101252	Drive Shaft	1	GE-402638	Control Side Panel (L-R)	1
GD-101253	Idler Shaft	1	GE-402639	Control Side Panel (R-L)	1
GB-112262	Bearing	1	GE-101491	Side Panel, Cord Side (R-L)	1
2U-Z11870	Drive Motor (right to left)	2	GE-101490	Side Panel, Cord Side (L-R)	1
2U-Z11871	Drive Motor (left to right)	1	GE-100955	Crumb Tray	2
GD-150023	Drive Chain	1	GE-402640	Load Up Tray	1
2P-115362	Driven Sprocket	1	GE-100944	Unload Tray	1
2P-200650	Drive sprocket	1	2R-200716	Leg, 2 ½" Metal	4
2E-200574	Fan Switch	1	PS-Z14660	Contactor/Relay, 40 amp	1
2E-200566	Reset Switch	2	GD-401206	Cover, Extensions	2
2U-200561	Fan Motor	1	2U-200579	Motor Controller	1
GE-402635	Control Box Cover	1	2P-200765	Bushing, Spring loaded	2
2R-200562	Grill Fan Motor	1	2P-200766	Spring	2

**OPERATOR'S MANUAL  
HOLMAN CONVEYOR OVENS  
MODEL 414HXM**

# DIAGRAM 020285

414HXM(R) SINGLE PHASE  
208, 220 & 240

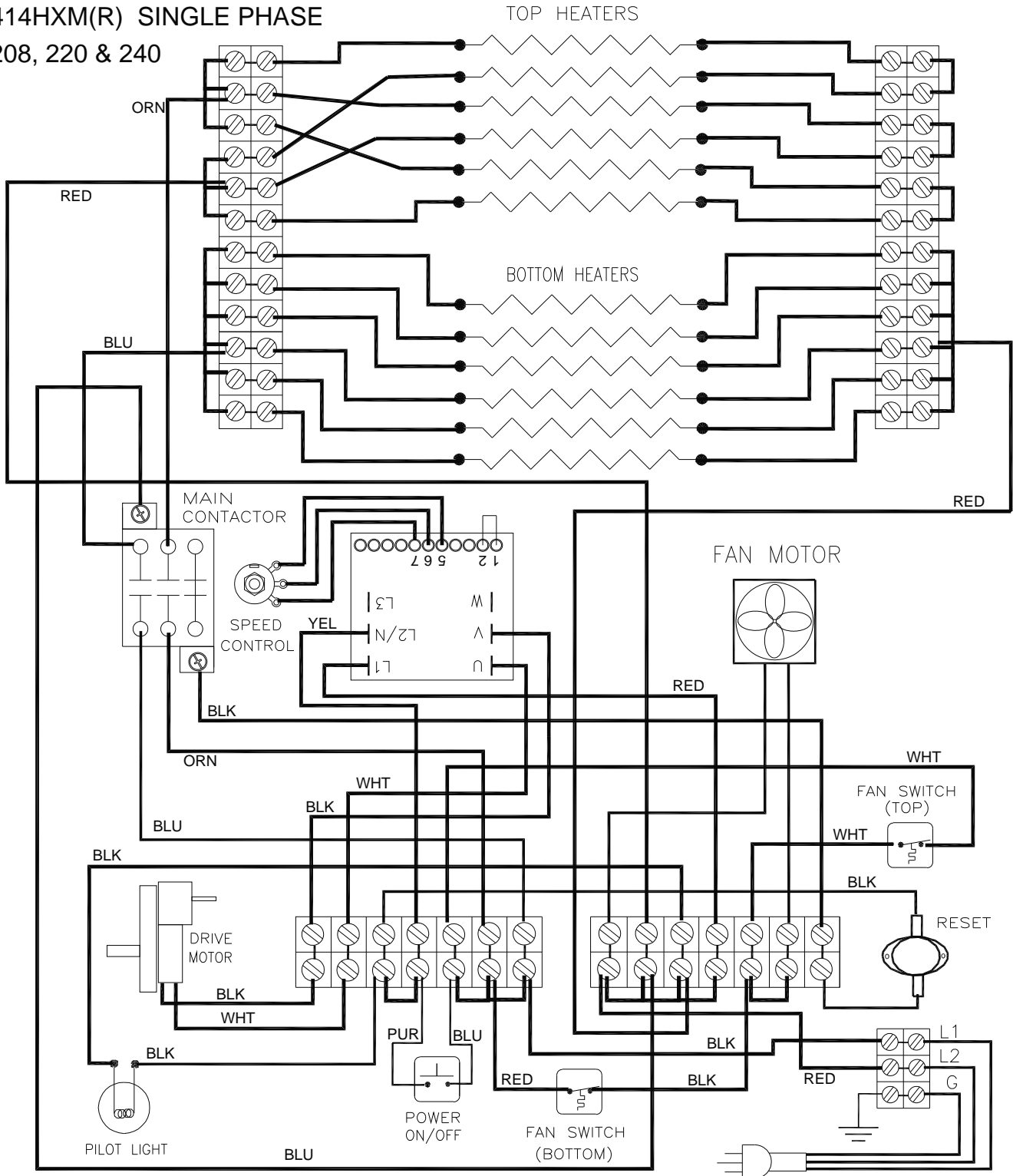

**OPERATOR'S MANUAL**  
**HOLMAN CONVEYOR OVENS**  
**MODEL 414HXM**

**DIAGRAM 020625**

414HXM(R) THREE PHASE  
208 & 240

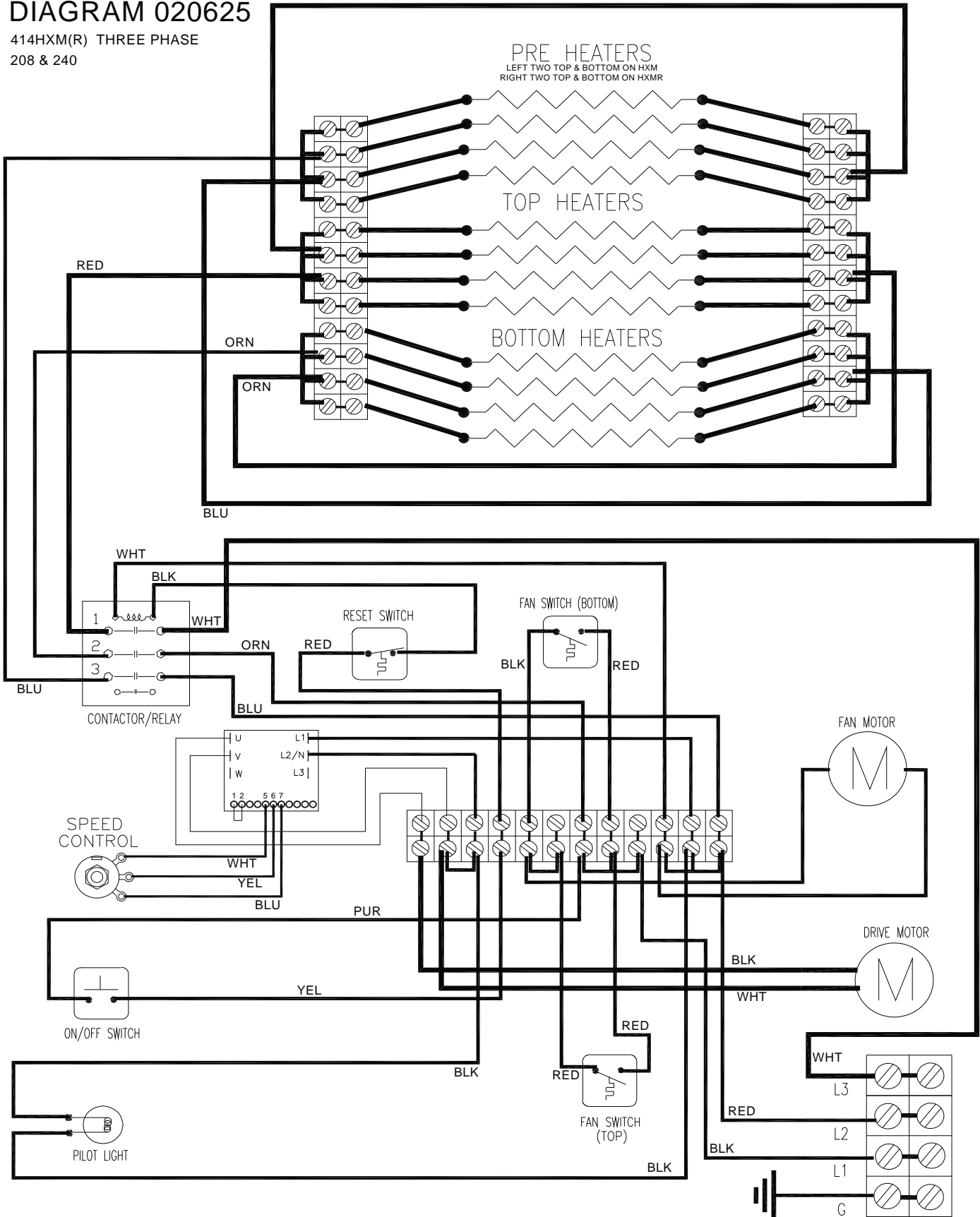



STAR INTERNATIONAL HOLDINGS INC. COMPANY  
Star - Holman - Lang - Wells - Bloomfield - Toastmaster  
10 Sunnen Drive, St. Louis, MO 63143 U.S.A.  
(314) 678-6303  
[www.star-mfg.com](http://www.star-mfg.com)