

MODEL: PROVEYOR
 314HX, 318HX, 418HX

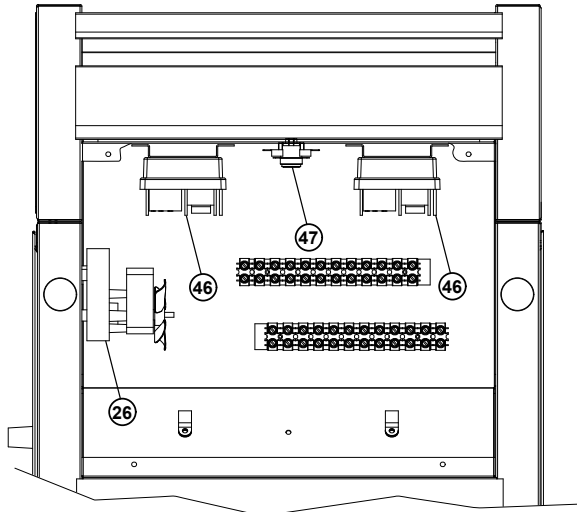

418HX Series Holman Conveyor Oven

Fig No.	Part Number	Quantity Per	Description	Fig No.	Part Number	Quantity Per	Description
1	GJ-401235	2	TRAY, CRUMB	34	2E-200180	6	SWITCH BARRIER, POT.
2	2A-200672	4	COLLAR, SHAFT	35	2J-200567	1	SWITCH, FRONT HEAT CONTROL POT. 3 PHASE
3	GJ-100710	1	RACK, BELT SUPPORT SYSTEM		2J-200567	1	SWITCH, TOP HEAT CONTROL POT.
4	GF-100405	1	TRAY, LOAD-UP	36	2J-200567	1	SWITCH, BOTTOM HEAT CONTROL POT. (Stratford Control)
5	2B-200619	1	LINK, CONVEYOR BELT	37	GB-118062	1	SWITCH, SPEED CONTROL (1000Ω)
	GF-160009	1	CONVEYOR BELT (14" X 75")	38	2J-200427	1	PILOT LIGHT
6	2B-200621	4	LINK, MASTER, CONVEYOR BELT	39	2R-200708	3	CAP, KNOB CONTROL
7	GJ-401161	1	COVER, TOP		2R-200708	4	CAP, KNOB CONTROL 3 PHASE
8	2A-200284	3	E-CLIP		2R-200768	3	KNOB, HEAT CONTROL, SPEED CONTROL
9	2C-200149	3	WASHER, BEARING		2R-200768	4	KNOB, HEAT CONTROL, SPEED CONTROL 3 PHASE
10	GB-112262	4	BUSHING 3/8"	40	2M-200873	1	LABEL, CONTROL PANEL
11	GF-101251	1	SHAFT ASSY IDLER		2M-200866	1	LABEL, CONTROL PANEL (3 PHASE)
12	2E-200574	1	SWITCH, FAN MOTOR	41	GJ-401381	1	PANEL, CONTROL SIDE
13	HG-402144	1	BRACKET, FAN SWITCH		GJ-401456	1	PANEL, CONTROL SIDE (3 PHASE)
14	GJ-401236	1	RETAINER, HEATER TUBE RIGHT	42	2U-200561	1	MOTOR, FAN
15	2J-200568	2	PROBE, HEAT (Stratford Control Model)	43	GF-402818	1	COVER, CONTROL BOX
	2J-200568	3	PROBE, HEAT (Stratford Control Model) 3 PHASE	44	2R-200562	1	GRILL, FAN MOTOR
16	GD-401206	4	COVER, EXTENSION SIDE	45	2C-Z5883	4	SCREW, 10-24 X 1/2 FZA, SELF DRILLING
17	GJ-400786	1	PANEL , CORD SIDE (L-R MODEL)	46	2J-200569	2	CONTROL, HEAT (Stratford Control)
	GD-401377	1	PANEL, CORD SIDE (R-L MODEL)		2J-200569	3	CONTROL, HEAT (Stratford Control) 3 PHASE
18	2K-200458	1	BUSHING, POWER SUPPLY CORD	47	2E-200566	1	SWITCH, HIGH LIMIT RESET
20	GF-101250	1	SHAFT ASSY DRIVE	48	SP-115339	2	CONTROL, HEAT (Phase Control)
21	GF-401289	2	SHUTTER, HEAT	49	2E-200529	1	CONTACTOR 3PH 3 Phase
22	GF-101404	1	TRAY, UNLOAD		2E-Z8966	1	CONTACTOR 50 AMP 208/240V 1PH 1 Phase
23	2P-150023	1	DRIVE CHAIN (27")	NI	GD-115392	1	TERMINAL BLOCK, 3 POS, LARGE (Power Input)
24	2P-200654	1	SPROCKET, DRIVEN (25B24 X 3/8")	NI	GD-115396	1	TERMINAL BLOCK, 7 POS. LARGE
25	2P-200643	1	SPROCKET, DRIVE (25B11 X 5/16")	NI	HM-115399	2	TERMINAL BLOCK, 10 POS. LARGE
26	2U-Z11871	1	MOTOR, DRIVE (L-R), CCW	NI	2E-200554	5	TERMINAL BLOCK, 12 POS. LARGE
	2U-200508	1	MOTOR, DRIVE 3286 BB REV, 50 hrz	NI	2P-115521	9	JUMPER, 2 POS. LARGE
27	2R-200721	1	BLADE, FAN, DRIVE MOTOR	NI	2P-115522	3	JUMPER, 3 POS. LARGE
28	2R-200716	4	LEG, 2 1/2" METAL	NI	GD-115523	1	JUMPER, 4 POS. LARGE
29	GJ-197881	12	HEATERTUBE QUARTZ 208V	NI	GJ-115525	1	JUMPER, 6 POS. LARGE
	GJ-197894	12	HEATERTUBE QUARTZ 220V	NI	1P-Z12397	1	EXTREME PRESSURE MULTIPURPOSE SYNTHETIC GREASE (80°F TO 400°F) , TUBE 1 oz.
	GJ-197882	12	HEATERTUBE QUARTZ 240V				
31	GD-401232	6	RETAINER, DUAL HEATER TUBES				
32	2E-200564	1	SWITCH, ON/OFF TOGGLE				
33	2P-401780	1	TOGGLE GUARD				



314 Stratford Control
Left to Right Conveyor

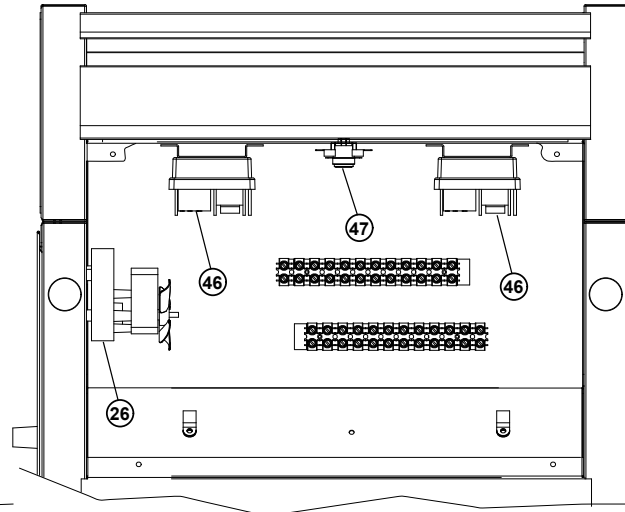

318 Stratford Control
Left to Right Conveyor

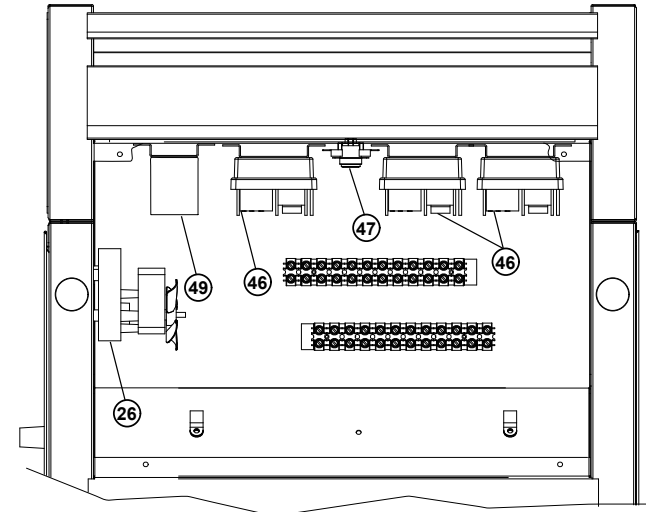

318 Stratford Control 3 Phase
Left to Right Conveyor

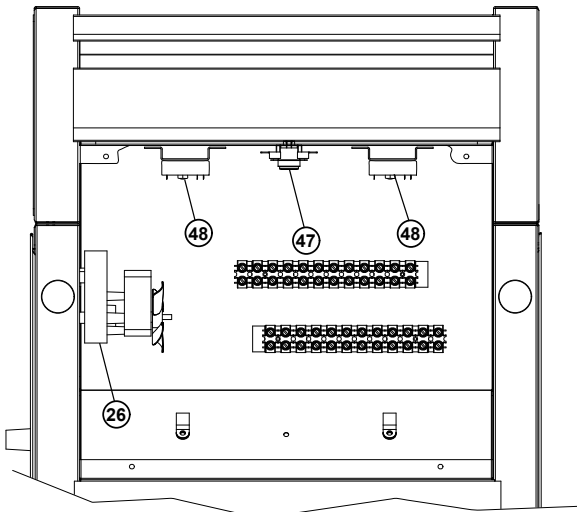

314 Phase Control
Left to Right Conveyor

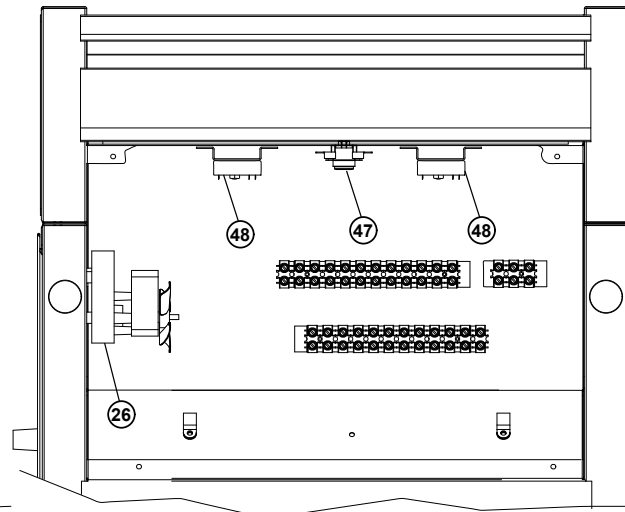

318 Phase Control
Left to Right Conveyor

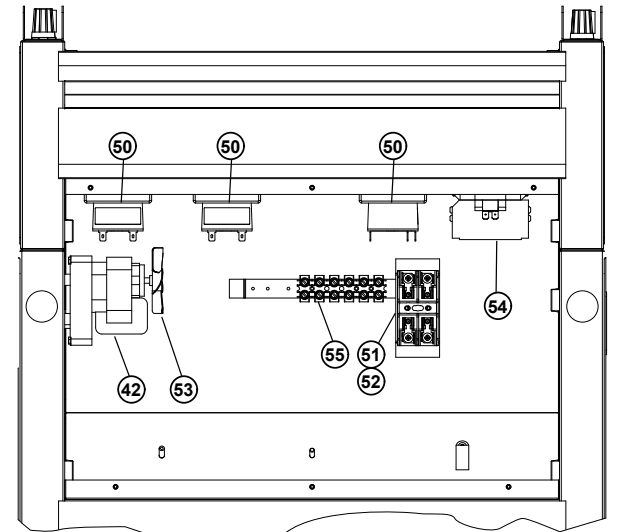

318HXGB
Pita Toaster

MODEL: PROVEYOR CONTROL BOX CONFIGURATION

SK2146 Rev. A 4/16/2010