

HOLMAN CONVEYOR TOASTERS**MODEL DT14-M****PARTS LIST**

<u>PART NUMBER</u>	<u>QTY.</u>	<u>DESCRIPTION</u>
100850	1	TOP COVER
*****	*	HEATER TUBES (REFER TO WIRE DIAGRAM)
402667	1	RETAINER, HEATER TUBES
160004	2	CONVEYOR BELT
100996	1	BACK PANEL
101362	1	SIDE PANEL (RIGHT)
101361	2	SIDE PANEL (LEFT)
SP-150002	1	DRIVE CHAIN (LOWER CONVEYOR), 13"
150024	1	DRIVE CHAIN (UPPER CONVEYOR), 26"
200648	1	SPROCKET (DRIVE MOTOR)
200643	1	SPROCKET (DRIVE SHAFT)
202902	1	DRIVE SHAFT
202905	1	IDLER SHAFT
112261	4	REAR BUSHING
200509	1	DRIVE MOTOR (LOWER CONVEYOR)
200504	1	DRIVE MOTOR (UPPER CONVEYOR)
200577	1	FAN MOTOR
200562	1	FAN GRILL
101031	2	CRUMB TRAYS
400899	1	HEAT SHUTTER
402475	1	TOAST CHUTE
101030	2	LOAD UP TRAY
200551	2	POWER SAVER SWITCH
200703	4	KNOB
118042	2	SPEED CONTROL SWITCH
200700	4	BUSHING, EXTENSION
200709	4	LEG, 1" PLASTIC
200386	1	POWER SUPPLY CORD
200566	2	RESET/HIGH LIMIT
200574	1	FAN SWITCH
402660	2	COVER, NON-LOCKING
402661	2	BRACKET, NON-LOCKING COVER
HG0303	1	McDONALDS SOP FOR MAINTENANCE
200736	4	2" SPRING, IDLER BUSHING

OPERATOR'S MANUAL

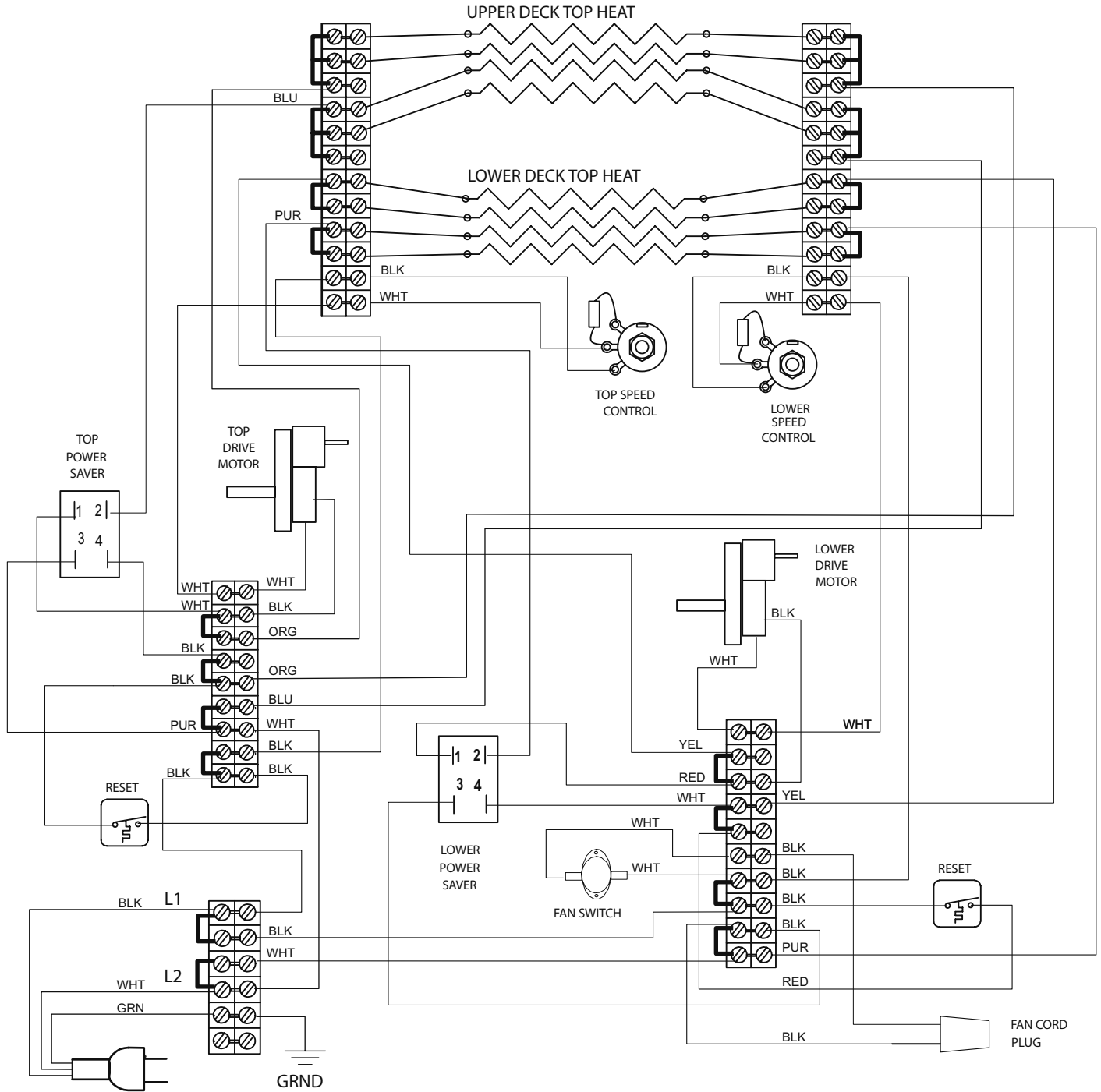

MODELS:
 DT14MA, 208/240V, 60Hz, 8 Tubes, McDonalds Resturants

METAL ELEMENTS:
 208V 2N-209208
 240V 2N-209211

