



**McDONALD'S
OPERATOR'S MANUAL
HOLMAN CONVEYOR TOASTERS
MODEL DT14-M**

**FOR SERVICE INFORMATION
U.S. AND CANADA CALL: TOLL FREE 1-800-807-9054
24 HOURS/DAY 7 DAYS/WEEK**

TABLE OF CONTENTS

UNCRATING AND INSPECTION	PAGE 2
ASSEMBLY AND INSTALLATION	PAGE 2
POWER SAVER SWITCHES	PAGE 3
COOKING PROCEDURES	PAGE 3
CLEANING PROCEDURES	PAGE 4
TROUBLESHOOTING GUIDE	PAGE 5
PARTS LIST	PAGE 6

DRAWINGS

TOAST CHUTE	PAGE 2
CRUMB TRAYS	PAGE 2
HIGH LIMIT RESET SWITCH	PAGE 2
ADJ. HEAT SHIELD, FRONT VIEW	PAGE 3
WIRING DIAGRAM	PAGE 7

OPERATOR'S MANUAL HOLMAN CONVEYOR TOASTERS

MODEL DT14

UNCRATING AND INSPECTION

Unpack unit and components from container. Remove all visible packing material and inspect unit for damage. If damage is discovered, call the factory immediately and tell us the extent of the damage.

ELECTRICAL INSTALLATION



WARNING: A CERTIFIED, LICENSED ELECTRICIAN MUST ELECTRICALLY INSTALL THIS UNIT.

WARNING: Make sure all input power is **off** before installing or removing any parts.

WARNING: Before installing unit(s), check with local power company to determine actual voltage at job site. Never use a 208-volt unit into 240 volts or a 240-volt unit into 208 volts.

WARNING: Be absolutely sure the ground connection for the unit is properly wired. Never connect unit to power without proper ground connections. Improper ground may result in severe injury or fatality.

INSTALLATION INSTRUCTIONS

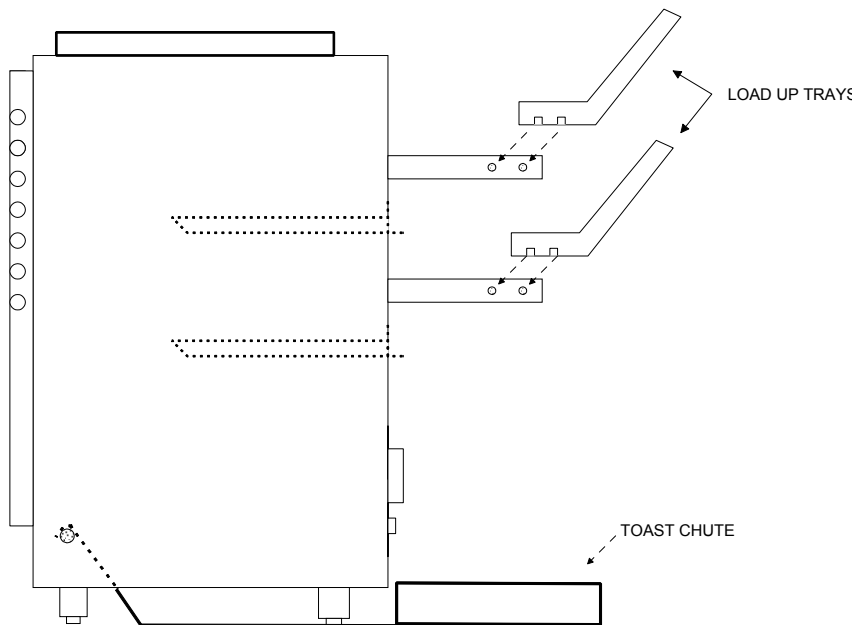

Attach the two load-up trays by hooking each tray over the mounting pins located on the side of each conveyor extension as shown above.

**OPERATOR'S MANUAL
HOLMAN CONVEYOR TOASTERS
MODEL DT14-M**

POWER SAVER SWITCH

Your Holman toaster is equipped with 2 rotary power saver switches.

FULL POWER- When in this position your unit is at Full Power and ready to use. Adjust the Top and Bottom Variable Heat Controls and Conveyor Belt Speed Control to your desired settings.

OFF-ROTARY- Two off positions are provided so that a single rotation to either direction will result in the unit being turned OFF.

STANDBY- The standby position reduces the power to the unit to 1/4, and therefore saves 75% of the energy consumption. In this position your unit will stay warm and reduce the reheat time when switched to Full Power to 20 to 30 seconds.

COOKING PROCEDURES

A. MUFFIN/BAGLE TOASTING

1. Turn the Power Saver Switch for the appropriate toaster chamber to FULL POWER.
2. Allow warm up time of 5 to 10 minutes. Test with product.

Refer to instructions on control panel label.

- If toasting is too light, turn conveyor speed control counterclockwise to a slower speed.
- If toasting is too dark, turn conveyor speed control clockwise to a faster speed.

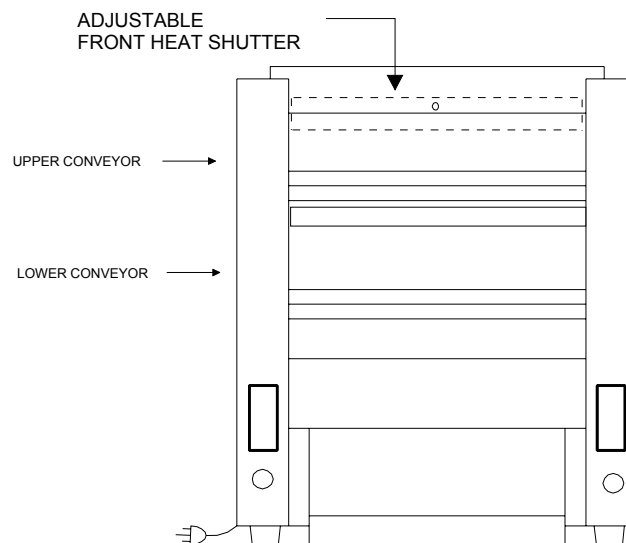

**OPERATOR'S MANUAL
HOLMAN CONVEYOR TOASTERS
MODEL DT14-M**

CLEANING PROCEDURES

1. Clean air intake on bottom of unit.
2. For lightly soiled conveyor belts, turn conveyor speed control to fastest setting and wipe with a damp cloth. For heavily soiled conveyors, turn conveyor speed control to fastest setting and wipe with a light abrasive pad.
3. Turn main power switch to the OFF position.
4. After the unit cools remove interior crumb tray (as shown below) and clean. Slide crumb tray back into position. **DO NOT OPERATE UNIT WITHOUT CRUMB TRAY IN PLACE AS THIS CAUSES OVERHEATING IN THE CONTROL BOX.**
5. Wipe exterior surface of unit.

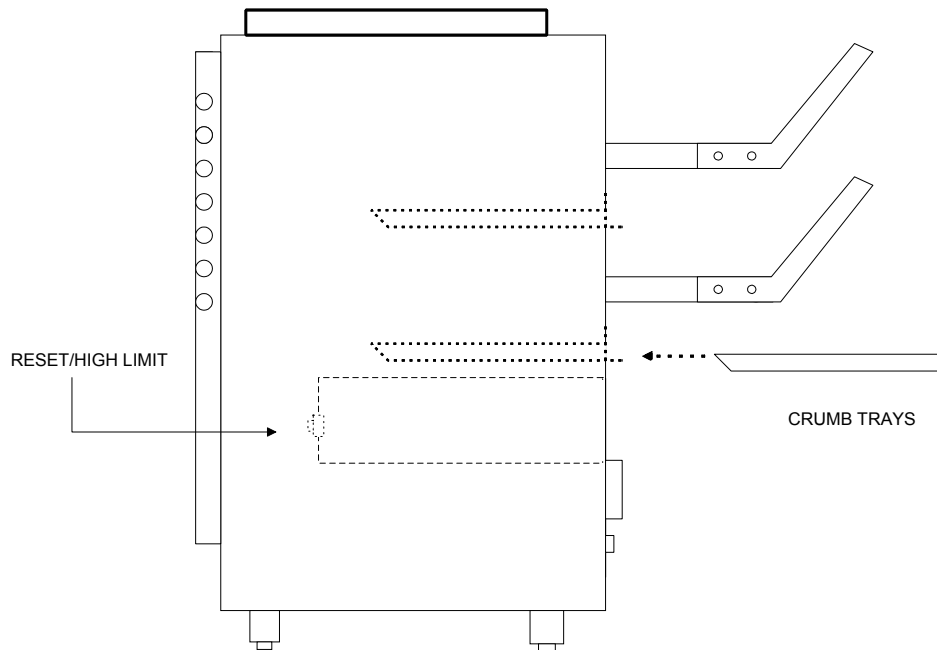

**REFER TO ENCLOSED LAMINATED MAINTENANCE SHEET INCLUDED WITH TOASTER
FOR FURTHER INSTRUCTIONS**

NOTE: LUBRICATION OF DRIVE CHAIN WITH GRAPHITE BASED LUBRICANT IS REQUIRED AS PERIODIC MAINTENANCE. CALL HOLMAN FACTORY SERVICE DEPARTMENT FOR DETAILS.

**OPERATOR'S MANUAL
HOLMAN CONVEYOR TOASTERS
MODEL DT14-M**

TROUBLESHOOTING GUIDE

A. UNIT WILL NOT HEAT, CONVEYOR BELT WILL NOT MOVE.

1. Make sure air intake on bottom of unit is clean.
2. Be sure the main circuit breaker is switched to the **ON** position.
3. Check to see if the toaster is plugged in and all controls are turned to the **ON** position.

B. UNIT HAS HEAT ONLY ON ONE SIDE, CONVEYOR BELT TURNS FREELY.

1. Call Holman Factory Service Department at **1-800-807-9054** as heating element may need replacing.

C. CONVEYOR BELT DOES NOT TURN, HEATER TUBES GET HOT.

To check for mechanical binding:

1. DISCONNECT UNIT FROM POWER SOURCE.
2. Remove screws (2 ea.) holding top cover in place at the rear of the unit.
3. Remove top cover (see page 10).
4. Remove each screw holding side panels in place and lift them up and out.
5. Loosen the four screws that hold the drive motor in place.
6. Slide the motor up allowing the drive chain to be removed from the sprockets.
7. Move the conveyor belt by hand to check for mechanical binding. If conveyor moves freely, call the Holman Factory Service Department at 1-800-225-3958 as the drive motor and/or speed control may need replacing.

**THE HOLMAN FACTORY SERVICE TEAM IS AVAILABLE 24 HOURS A DAY/7DAYS A WEEK FOR
TECHNACLE ASSISTANCE CALL 1-800-807-9054**

THOROUGHLY INSPECT YOUR UNIT ON ARRIVAL

This unit has been tested for proper operation before leaving our plant to insure delivery of your unit in perfect condition. However, there are instances in which the unit may be damaged in transit. In the event you discover any type of damage to your product upon receipt, you must immediately contact the transportation company who delivered the item to you and initiate your claim with same. If this procedure is not followed, it may affect the warranty status of the unit.

LIMITED EQUIPMENT WARRANTY

All workmanship and material in Star products have a one (1) year limited warranty on parts & labor in the United States and Canada. Such warranty is limited to the original purchaser only and shall be effective from the date the equipment is placed in service. Star's obligation under this warranty is limited to the repair of defects without charge, by the factory authorized service agency or one of its sub-agencies. Models that are considered portable (*see below*) should be taken to the closest Star service agency, transportation prepaid.

- > Star will not assume any responsibility for loss of revenue.
- > On all shipments outside the United States and Canada, see International Warranty.
- * The warranty period for the JetStar series six (6) ounce popcorn machines is two (2) years.
- * The warranty period for the Chrome-Max Griddles is five (5) years on the griddle surface. See detailed warranty provided with unit.
- * The warranty period for Teflon/Dura-Tec coatings is one year under normal use and reasonable care. This warranty does not apply if damage occurs to Teflon/Dura-Tec coatings from improper cleaning, maintenance, use of metallic utensils, or abrasive cleaners. This warranty does not apply to the "non-stick" properties of such materials.
- > This warranty does not apply to "Special Products" but to regular catalog items only. Star's warranty on "Special Products" is six (6) months on parts and ninety (90) days on labor.
- > This warranty does not apply to any item that is disassembled or tampered with for any purpose other than repair by a Star Authorized Service Center or the Service Center's sub-agency.
- > This warranty does not apply if damage occurs from improper installation, misuse, wrong voltage, wrong gas or operated contrary to the Installation and Operating instructions.
- > This warranty is not valid on Conveyor Ovens *unless* a "start-up/check-out" has been performed by a Factory Authorized Technician.

PARTS WARRANTY

Parts that are sold to repair out of warranty equipment are warranted for ninety (90) days. The part only is warranted. Labor to replace the part is chargeable to the customer.

SERVICES NOT COVERED BY WARRANTY

- | | |
|----------------------------------------------------------------------------------------------------------------------------------------------------------------------|-------------------------------------------------------------------------------------------------|
| 1. Travel time and mileage rendered beyond the 50 mile radius limit | 10. Voltage conversions |
| 2. Mileage and travel time on portable equipment (<i>see below</i>) | 11. Gas conversions |
| 3. Labor to replace such items that can be replaced easily during a daily cleaning routine, ie; removable kettles on fryers, knobs, grease drawers on griddles, etc. | 12. Pilot light adjustment |
| 4. Installation of equipment | 13. Miscellaneous adjustments |
| 5. Damages due to improper installation | 14. Thermostat calibration and by-pass adjustment |
| 6. Damages from abuse or misuse | 15. Resetting of circuit breakers or safety controls or reset buttons |
| 7. Operated contrary to the Operating and Installation Instructions | 16. Replacement of bulbs |
| 8. Cleaning of equipment | 17. Replacement of fuses |
| 9. Seasoning of griddle plates | 18. Repair of damage created during transit, delivery, & installation OR created by acts of God |

PORTABLE EQUIPMENT

Star will not honor service bills that include travel time and mileage charges for servicing any products considered "Portable" including items listed below. These products should be taken to the Service Agency for repair:

- * The Model 510FD Fryer.
- * The Model J4R, 4 oz. Popcorn Machine.
- * The Model 518CMA & 526CMA Cheese Melter.
- * The Model 12MC & 15MC & 18MCP Hot Food Merchandisers.
- * The Model 12NCPW & 15NCPW Nacho Chip/Popcorn Warmer.
- * All Hot Dog Equipment **except Roller Grills & Drawer Bun Warmers.**
- * All Nacho Cheese Warmers **except Model 11WLA Series Nacho Cheese Warmer.**
- * All Condiment Dispensers **except the Model HPDE, & SPDE Series Dispenser.**
- * All Specialty Food Warmers **except Model 130R, 11RW Series, and 11WSA Series.**
- * All QCS/RCS Series Toasters **except Model QCS3 & RCS3 Series.**

ALL:

- * Pop-Up Toasters
- * Butter Dispensers
- * Pretzel Merchandisers
- * Pastry Display Cabinets
- * Nacho Chip Merchandisers
- * Accessories of any kind
- * Sneeze Guards
- * Pizza Ovens
- * Heat Lamps
- * Pumps

The foregoing warranty is in lieu of any and all other warranties expressed or implied and constitutes the entire warranty.

FOR ASSISTANCE

Should you need any assistance regarding the Operation or Maintenance of any Star equipment; write, phone, fax or email our Service Department. In all correspondence mention the Model number and the Serial number of your unit, and the voltage or type of gas you are using.

HOLMAN CONVEYOR TOASTERS**MODEL DT14-M****PARTS LIST**

<u>PART NUMBER</u>	<u>QTY.</u>	<u>DESCRIPTION</u>
100850	1	TOP COVER
*****	*	HEATER TUBES (REFER TO WIRE DIAGRAM)
402667	1	RETAINER, HEATER TUBES
160004	2	CONVEYOR BELT
100996	1	BACK PANEL
101362	1	SIDE PANEL (RIGHT)
101361	2	SIDE PANEL (LEFT)
SP-150002	1	DRIVE CHAIN (LOWER CONVEYOR), 13"
150024	1	DRIVE CHAIN (UPPER CONVEYOR), 26"
200648	1	SPROCKET (DRIVE MOTOR)
200643	1	SPROCKET (DRIVE SHAFT)
202902	1	DRIVE SHAFT
202905	1	IDLER SHAFT
112261	4	REAR BUSHING
200509	1	DRIVE MOTOR (LOWER CONVEYOR)
200504	1	DRIVE MOTOR (UPPER CONVEYOR)
200577	1	FAN MOTOR
200562	1	FAN GRILL
101031	2	CRUMB TRAYS
400899	1	HEAT SHUTTER
402475	1	TOAST CHUTE
101030	2	LOAD UP TRAY
200551	2	POWER SAVER SWITCH
200703	4	KNOB
118042	2	SPEED CONTROL SWITCH
200700	4	BUSHING, EXTENSION
200709	4	LEG, 1" PLASTIC
200386	1	POWER SUPPLY CORD
200566	2	RESET/HIGH LIMIT
200574	1	FAN SWITCH
402660	2	COVER, NON-LOCKING
402661	2	BRACKET, NON-LOCKING COVER
HG0303	1	McDONALDS SOP FOR MAINTENANCE
200736	4	2" SPRING, IDLER BUSHING

OPERATOR'S MANUAL

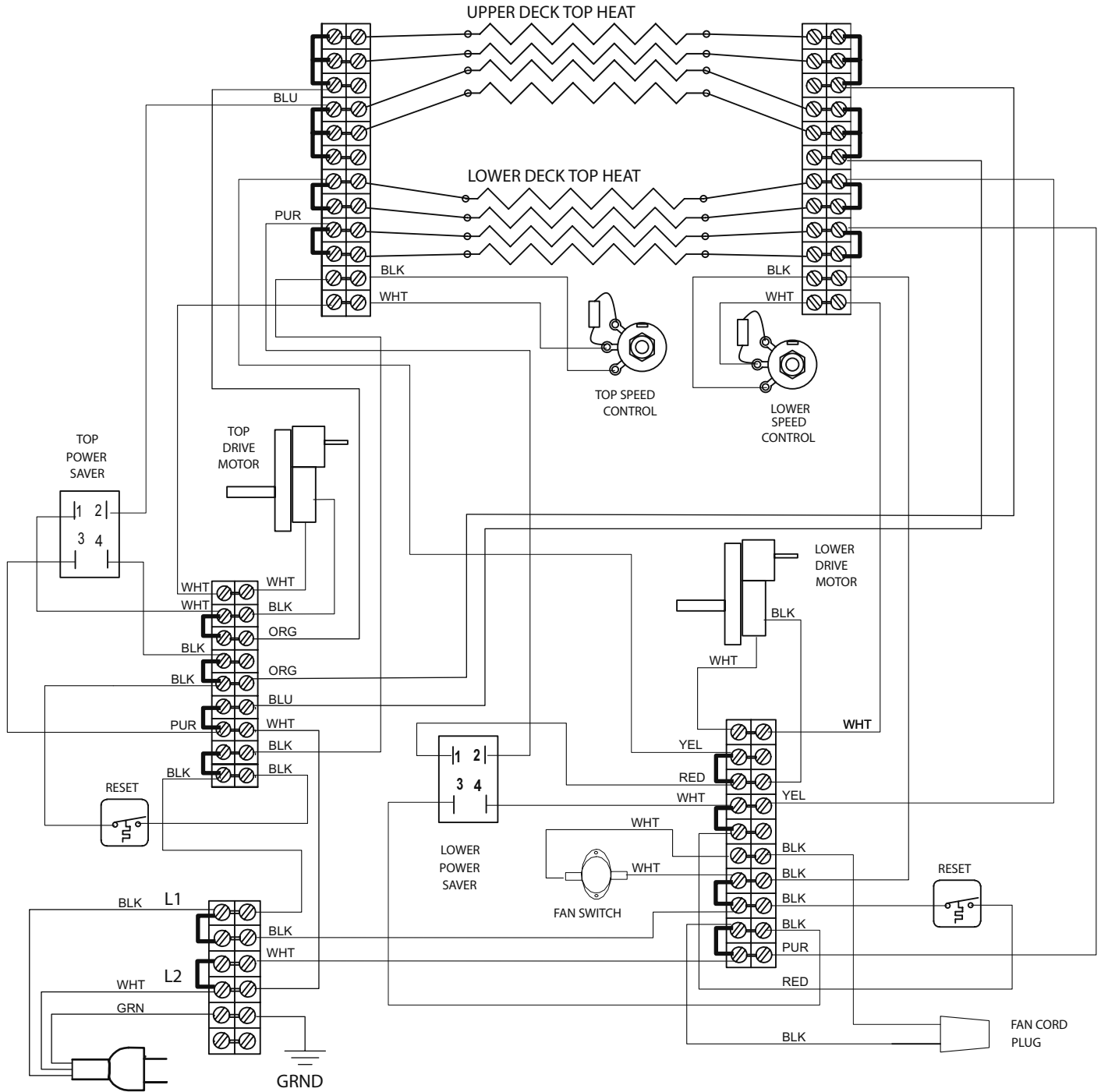

MODELS:
 DT14MA, 208/240V, 60Hz, 8 Tubes, McDonalds Resturants

METAL ELEMENTS:
 208V 2N-209208
 240V 2N-209211

