

STAR[®] EGG COOKER

MODEL
EC14PB-240V

Installation and Operation Instructions

2M-Z11369 Rev.- 2/1/08

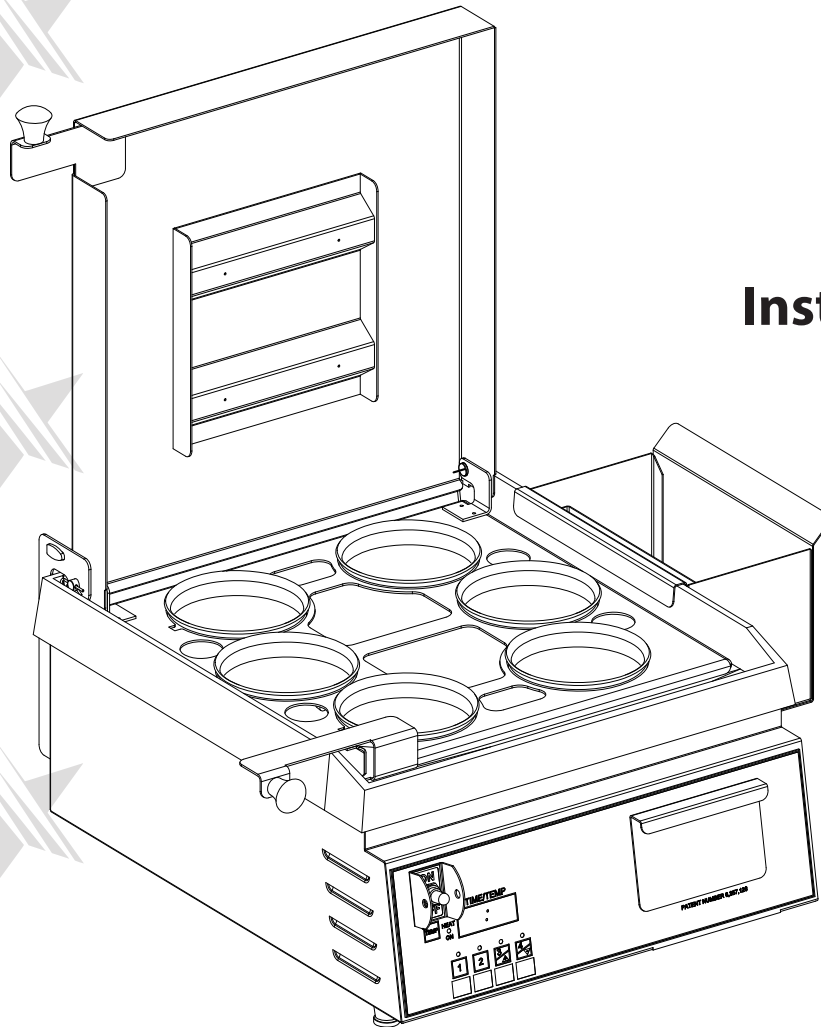

EC14PB-240V

SAFETY SYMBOL



These symbols are intended to alert the user to the presence of important operating and maintenance instructions in the manual accompanying the appliance.

RETAIN THIS MANUAL FOR FUTURE REFERENCE NOTICE

Using any part other than genuine Star factory supplied parts relieves the manufacturer of all liability.

Star reserves the right to change specifications and product design without notice. Such revisions do not entitle the buyer to corresponding changes, improvements, additions or replacements for previously purchased equipment.

Due to periodic changes in designs, methods, procedures, policies and regulations, the specifications contained in this sheet are subject to change without notice. While Star Manufacturing exercises good faith efforts to provide information that is accurate, we are not responsible for errors or omissions in information provided or conclusions reached as a result of using the specifications. By using the information provided, the user assumes all risks in connection with such use.

MAINTENANCE AND REPAIRS

Contact your local authorized service agent for service or required maintenance. Please record the model number, serial number, voltage and purchase date in the area below and have it ready when you call to ensure faster service.

Model No. _____
Serial No. _____
Voltage _____
Purchase Date _____

Authorized Service Agent

Reference the listing provided with the unit

or

for an updated listing go to:

Website: www.star-mfg.com
E-mail: Service@star-mfg.com
Telephone: (800) 807-9054 Local (314) 781-2777

The Star Service Help Desk

Business Hours: 8:00 am to 4:30 p.m. Central Standard Time

Telephone: (800) 807-9054 Local (314) 781-2777

Fax: (800) 396-2677 Local (314) 781-2714

E-mail: Parts@star-mfg.com
Service@star-mfg.com
Warranty@star-mfg.com

Website: www.star-mfg.com

Mailing Address: Star Manufacturing International Inc.
10 Sunnen Drive
St. Louis, MO 63143
U.S.A

GENERAL SPECIFICATIONS

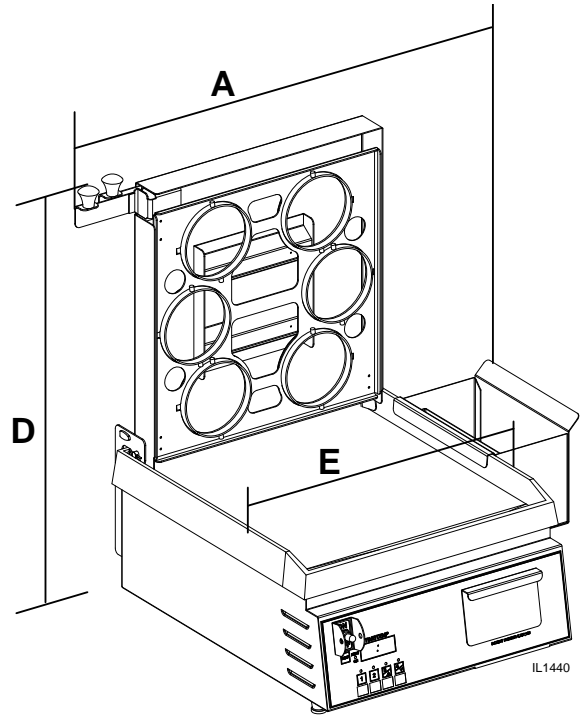
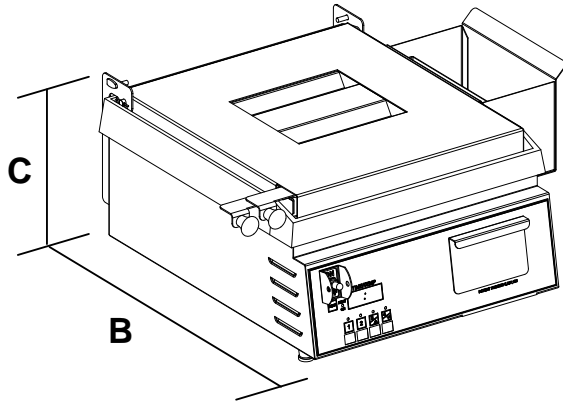

| Model No | Grill Surface | (A) Width Inches (cm) | (B) Depth Inches (cm) | (C) Closed Inches (cm) | (D) Open Inches (cm) | (E) Grill Width Inches (cm) |
|-------------|---------------|-----------------------|-----------------------|------------------------|----------------------|-----------------------------|
| EC14PB-240V | Alum. | 23.22 (59) | 18.76 (47.7) | 8.82 (22.4) | 23.97 (60.9) | 15.25 (38.7) |

| Model No | Voltage | Wattage | Amps | NEMA Plug | Approximate Weight | |
|-------------|---------|---------|------|-----------|--------------------|---------------------|
| | | | | | Shipping lbs. (kg) | Installed lbs. (kg) |
| EC14PB-240V | 240V | 2150 | 8.96 | 6-15P | TBD | |

GRILL COMPONENTS

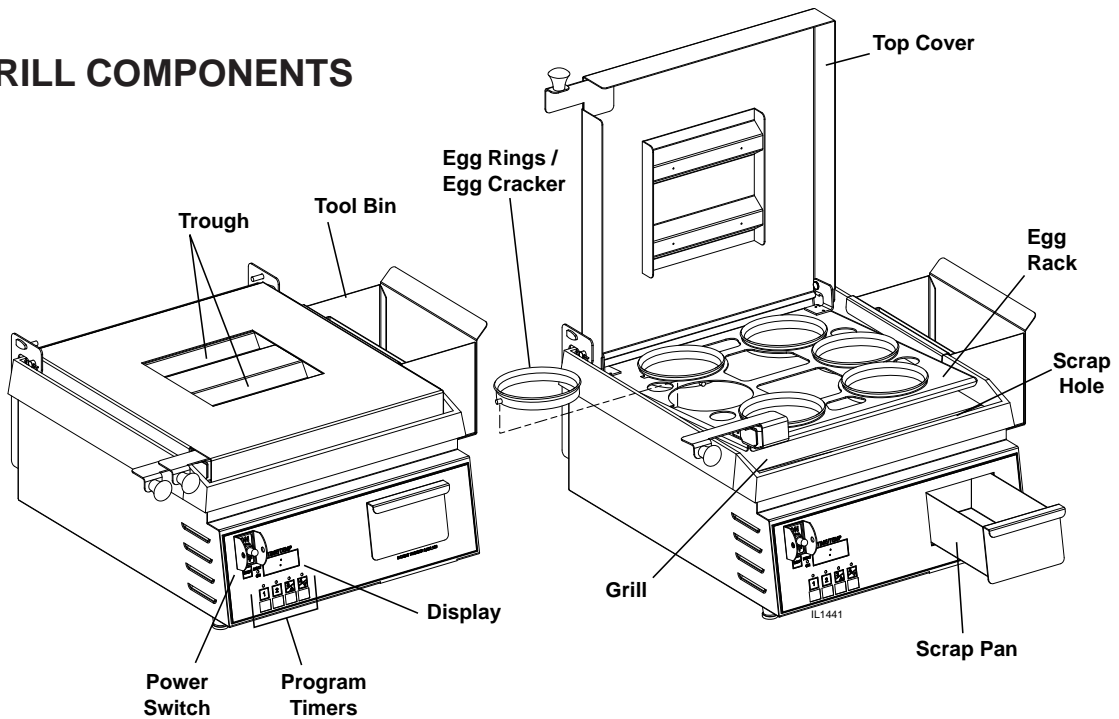

GENERAL INSTALLATION DATA



This equipment is designed and sold for commercial use only by personnel trained and experienced in its operation and is not sold for consumer use in and around the home nor for use directly by the general public in food service locations.

Before using your new equipment, read and understand all the instructions & labels associated with the unit prior to putting it into operation. Make sure all people associated with its use understand the units operation & safety before they use the unit.

All shipping containers should be checked for freight damage both visible and concealed. This unit has been tested and carefully packaged to insure delivery of your unit in perfect condition. If equipment is received in damaged condition, either apparent or concealed, a claim must be made with the delivering carrier.

Concealed damage or loss - if damage or loss is not apparent until after equipment is unpacked, a request for inspection of concealed damage must be made with carrier within 15 days. Be certain to retain all contents plus external and internal packaging materials for inspection. The carrier will make an inspection and will supply necessary claim forms.

INSTALLATION

1. This grill/steamer is equipped for the voltage shown on the nameplate.

It will operate on alternating current only, however the specified voltage must be applied.

2. 240 volt units do not require a dedicated 240 VAC circuit with a 15 Amp receptacle.



DO NOT CONNECT THE UNIT TO ANY TYPE OF VOLTAGE OTHER THAN THAT ON THE NAMEPLATE. DOING SO WILL DAMAGE THE UNIT AND VOID THE WARRANTY.

UNPACKING

1. The unit will arrive completely assembled, remove unit from its packaging and confirm all necessary parts are present and in good working condition. If damage occurred during shipping please contact carrier within 15 days, be certain to keep all packaging for their inspection.

2. Remove the scrap pan, tool bin and top cover / egg rack assembly from the unit by loosening the thumb screws, as shown here and clean using warm water and mild detergent, rinse thoroughly.

3. Once dry, reassembly all parts.

INITIAL START UP

Before using the unit for the first time, wipe down the exterior and grilling area with a damp cloth. Take to a well ventilated area and heat for approximately 30 minutes. The grill may emit a small amount of smoke as the cooking surfaces reach the setpoint temperature of 300°F (149°C). Do not be alarmed, as the smoke is caused by oils associated with the manufacturing process and will stop when the burn off is complete. Brush off any debris from the grilling surface.

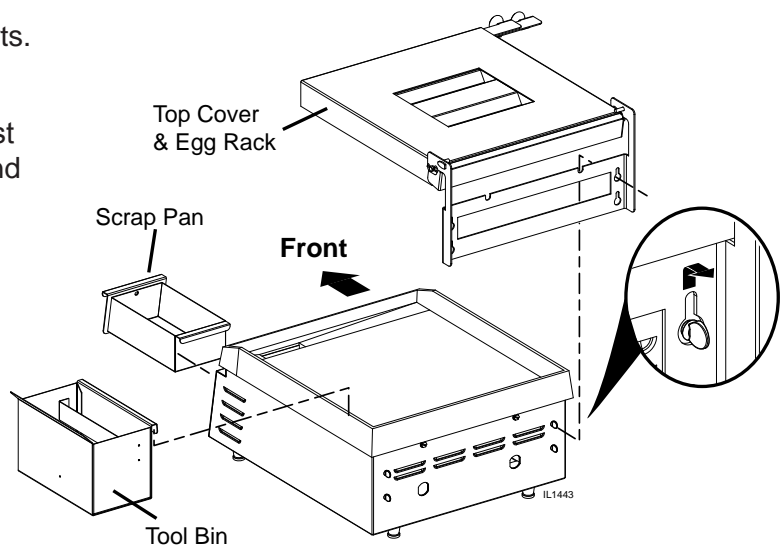

Once cooled move to permanent location and level unit using the adjustable feet under the unit (approximately 1/2" adjustment).

SEASONING THE COOKING SURFACES

FIRST TIME SEASONING

Follow your company/corporate guidelines for seasoning cooking surfaces. or

1. Bring the grill to 300°F (149°C) and leave it on while doing the next two steps.
2. **Brush** the cooking surfaces with a **SALT-FREE** release agent. If using an aerosol agent, first apply into a cup and then brush onto cooking surface.
3. Let sit for 20 minutes, and then wipe clean using a warm damp cloth.

IMPORTANT Using a releasing agent with a salt content will create favor overtones on the food prepared as well as increase the material buildup on the cooking surface, making cleaning more difficult.

DAILY SEASONING

The grill should not require much seasoning while in use. In most cases, brush a light coating of a **SALT-FREE** baking release agent in the morning and occasionally throughout the day will be enough to prevent any sticking. It is not necessary to brush before grilling each item.

°F/°C CONVERSION

To change the temperature display from °F to °C or from °C to °F, hold the TEMP button while the unit is turned off. While holding the TEMP button, turn the unit on. The display will be the changed temperature mode. To change back, repeat the procedure.

OPERATING INSTRUCTIONS

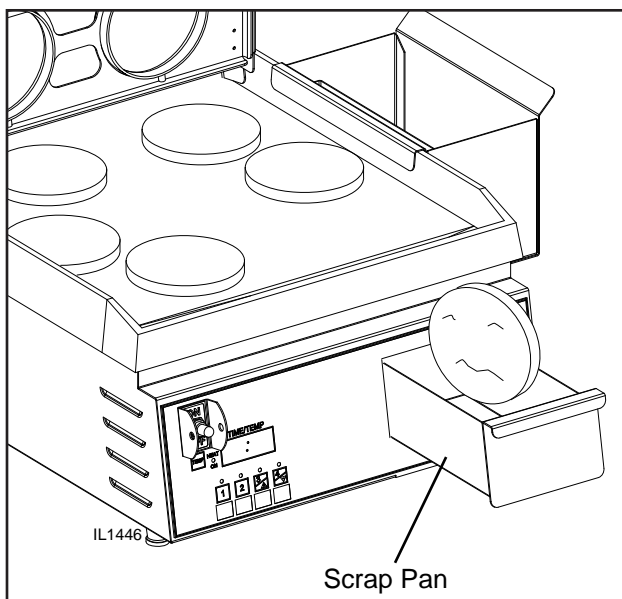
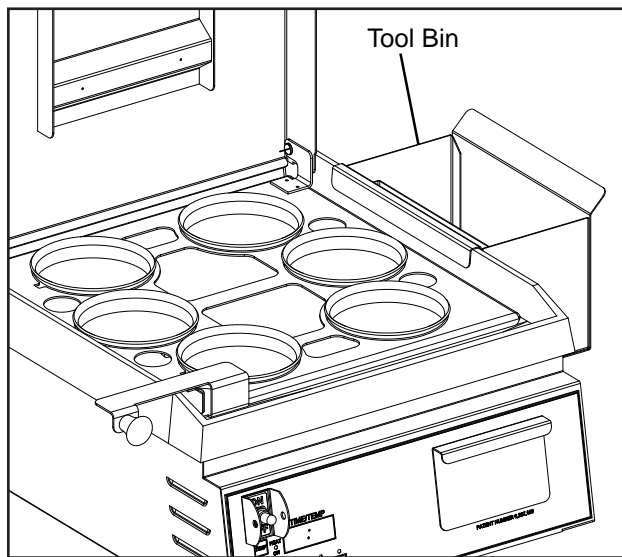
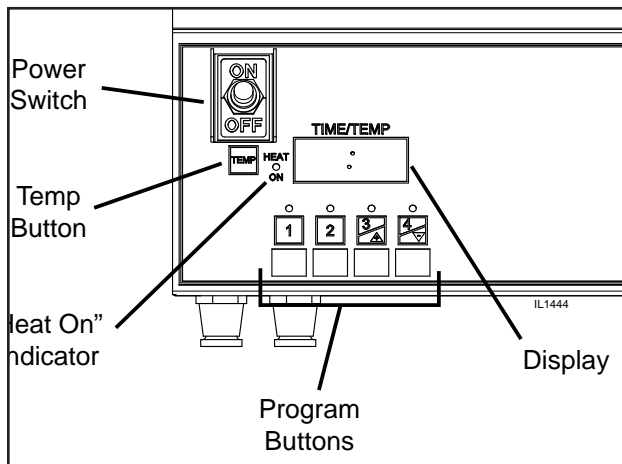

1. Turn unit on by placing power switch in "ON" position. The "Heat On" indicator, program number indicator and display will flash indicating unit is heating. When the preset temperature is reached, the **Heat On Indicator**, display and program light indicator will stop flashing followed by 3 beeps. (Initial startup heating time is approx. 30 minutes).
2. Open Cover and brush the egg ring areas with a salt-free releasing agent.

IMPORTANT

Using a releasing agent with a salt content will create favor overtones on the food prepared as well as increase the material buildup on the cooking surface, making cleaning more difficult.

3. Crack eggs using the egg ring (one-per ring) and drop them into egg rings, discard shells. Break egg yolks with a spatula or fork, place spatula/fork into tool bin to prevent spreading bacteria on your work surfaces.
4. Close cover, fill both troughs on top of the cover with water.
5. Press the program button, display will count down to "00:00" at which time unit will beep. Turn off the beep by pressing the program button again.
6. Lift both covers, eggs will remain in position on the cooking surface, **if not**, drop the rack around one - two inches onto the grill surface to loosen eggs.
7. If you wish to grill the eggs on the opposite side, flip at this time and press the 30 second program timer, leaving the top cover open.

Note: see "Changing Program Time.." section to record a second program setting.

8. Remove eggs from the grill and using a spatula scrape residue into service pan.

Note: Metal utensils with rounded corners may be used, however, using nonmetal utensils will prolong the life of the cooking surface.

9. Egg scraps or failed attempts can be discarded in the scrap pan as shown here. Check regularly & empty when needed.

8. Turn the unit off when not in use.

PRESET TIME AND TEMPERATURE

This 240V unit comes with an LED Timer Controller, which has four (4) individual program settings. All of these programs come preset to 300°F at 3:00 minutes from the factory.

By following the steps below you can change a program to fit your specific needs, giving you more flexibility in your menu offerings. For example, simply by programming a second buttons for 30 seconds allows you to grill the opposite side for a consistent period of time.

The steps below will better familiarize you with your unit's program capabilities.

Startup:

1. The preset time will flash until preset temperature is reached.
2. When the control reaches preset temperature, time display, "Heat On" indicator and program indicator will stop flashing and the alarm will beep three times.

Temperature:

1. To view the actual temperature, press and hold "Temp Button." Display will read "Lo F" if temperature is below 273°F (134°C) and "Hi F" if temperature is above 573°F (301°C).

Operation:

1. Pressing any program button (1-4) will start the timer countdown and display the preset time remaining. The LED for the appropriate program will be lit during countdown and remain lit until another program is selected.
2. When the display reaches "00:00", the buzzer will sound and the digits will flash.
3. Press the program button to silence the buzzer and return the readout to programmed time.
4. The right and left sides will operate independently of each other. Both timers can be in operation at the same time. The "00:00" display will show which side is timed out.

Changing Program Time and Temperature:

1. Press and hold "TEMP" (actual temperature displays).
2. While holding "TEMP," press and hold any program button on the Left one second, the LED above the program number light and the display reads "____." Enter the four-digit security code sequence, **4, 3, 2, 1**. The security code **will not** show on the display. Once the correct sequence has been entered, the preset time will be displayed and the LED for that program will begin to flash.
3. Set the time with the "+" or "-" buttons.
4. **Press the "TEMP" button to save the time.**
5. The preset temperature will now be displayed.
6. Set the desired temperature for this program using the "+" or "-" buttons.
7. **Press the "TEMP" button to save temperature and to exit programming mode for this program. The LED will stop flashing but will remain lit.**
8. **Press any other program button within 15 seconds to continue programming without re-entering the security code.**
9. **While programming a program (LED is flashing), if no input is received for 15 seconds, the unit will revert to normal operation and the security code must be re-entered.**

Note: Temperature settings are done with the left side buttons only. The time settings programmed on the Left buttons will also be programmed onto the **right side**. See below to make time changes to the **right side** only. **Each programming change must be saved by pressing the "TEMP" button!**

MAINTENANCE

MONTHLY INSPECTION

Check all bolts/screws and tighten if necessary.

CLEANING

Begin cleaning procedure by using the operating procedures within your organization, or follow the steps below:

1. If particles adhere to the cooking surface during the day, scrape them off with a spatula.
NOTE: It is best not to let food residue onto the grill, as food build-up on the grill will increase sticking and smoking. In addition, carbon may build up on the grill surface and reduce the cooking efficiency.

CARBON BUILDUP: A black matter that forms on or near the cooking surface. Generally this is a combination of: releasing agents, oils, food particles etc. that has cooked itself to the surface. After a period of time without cleaning, this will reduce performance and material may start flaking off. When that happens, follow the "Carbon Cleaning" procedures.

2. At the end of the day, wipe down all surfaces with a warm, damp cloth and mild detergent, then dry.

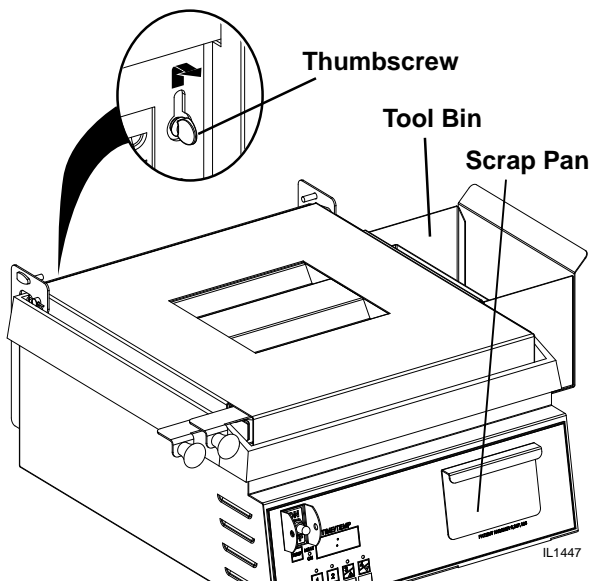

Cleaning the Cover & Egg Rack Assembly

1. Once cooled, remove the cover & egg rack & ring assembly by loosening the 4 thumb screws located at the rear of the unit and simply lifting up and back.
2. Remove and empty the scrap pan & tool bin
3. Clean using warm water and mild detergent.
4. Once Dry, reassemble

CARBON CLEANING

When carbon build up occurs, use a carbon removal agent (safe for aluminum & chrome surfaces) according to the instructions provided with the cleaner. When this process is complete, you must re-season the grill according to your company/corporate guidelines, or the seasoning instructions in this manual.



DO NOT IMMERSE OR LET THE UNIT STAND IN WATER. DO NOT HOSE DOWN THE UNIT. KEEP THE UNIT AWAY FROM RUNNING WATER.

**CAUTION DO NOT SPLASH THE CONTROL HOUSING!
DO NOT USE ICE ON COOKING SURFACE!**



BEFORE CLEANING ALL OTHER UNITS MAKE SURE POWER IS TURNED OFF, UNIT IS UNPLUGGED AND HAS BEEN ALLOWED TO COOL.

WARNING

To remove burned on grease or food residue use the following mixture:
1 Tablespoon liquid dish detergent
1 Cup of warm water

While holding top lid with one hand, apply this mixture to cold or warm top cooking surface with a sponge or plastic scrubbing pad. Wipe with clean sponge or towel until it is clean.

Empty and clean scrap pan & as required using detergent and water after removing tray from unit.

Visit our Website at: www.star-mfg.com

Email: service@star-mfg.com

THOROUGHLY INSPECT YOUR UNIT ON ARRIVAL

This unit has been tested for proper operation before leaving our plant to insure delivery of your unit in perfect condition. However, there are instances in which the unit may be damaged in transit. In the event you discover any type of damage to your product upon receipt, you must immediately contact the transportation company who delivered the item to you and initiate your claim with same. If this procedure is not followed, it may affect the warranty status of the unit.

LIMITED EQUIPMENT WARRANTY

All workmanship and material in Star products have a one (1) year limited warranty on parts & labor in the United States and Canada. Such warranty is limited to the original purchaser only and shall be effective from the date the equipment is placed in service. Star's obligation under this warranty is limited to the repair of defects without charge, by the factory authorized service agency or one of its sub-agencies. Models that are considered portable (*see below*) should be taken to the closest Star service agency, transportation prepaid.

- > Star will not assume any responsibility for loss of revenue.
- > On all shipments outside the United States and Canada, see International Warranty.
- * The warranty period for the JetStar six (6) ounce & Super JetStar eight (8) ounce series popcorn machines is two (2) years.
- * The warranty period for the Chrome-Max Griddles is five (5) years on the griddle surface. See detailed warranty provided with unit.
- * The warranty period for Teflon/Dura-Tec coatings is one year under normal use and reasonable care. This warranty does not apply if damage occurs to Teflon/Dura-Tec coatings from improper cleaning, maintenance, use of metallic utensils, or abrasive cleaners. This warranty does not apply to the "non-stick" properties of such materials.
- > This warranty does not apply to "Special Products" but to regular catalog items only. Star's warranty on "Special Products" is six (6) months on parts and ninety (90) days on labor.
- > This warranty does not apply to any item that is disassembled or tampered with for any purpose other than repair by a Star Authorized Service Center or the Service Center's sub-agency.
- > This warranty does not apply if damage occurs from improper installation, misuse, wrong voltage, wrong gas or operated contrary to the Installation and Operating instructions.
- > This warranty is not valid on Conveyor Ovens *unless* a "start-up/check-out" has been performed by a Factory Authorized Technician.

PARTS WARRANTY

Parts that are sold to repair out of warranty equipment are warranted for ninety (90) days. The part only is warranted. Labor to replace the part is chargeable to the customer.

SERVICES NOT COVERED BY WARRANTY

1. Travel time and mileage rendered beyond the 50 mile radius limit
2. Mileage and travel time on portable equipment (*see below*)
3. Labor to replace such items that can be replaced easily during a daily cleaning routine, ie; removable kettles on fryers, knobs, grease drawers on griddles, etc.
4. Installation of equipment
5. Damages due to improper installation
6. Damages from abuse or misuse
7. Operated contrary to the Operating and Installation Instructions
8. Cleaning of equipment
9. Seasoning of griddle plates
10. Voltage conversions
11. Gas conversions
12. Pilot light adjustment
13. Miscellaneous adjustments
14. Thermostat calibration and by-pass adjustment
15. Resetting of circuit breakers or safety controls or reset buttons
16. Replacement of bulbs
17. Replacement of fuses
18. Repair of damage created during transit, delivery, & installation OR created by acts of God

PORTABLE EQUIPMENT

Star will not honor service bills that include travel time and mileage charges for servicing any products considered "Portable" including items listed below. These products should be taken to the Service Agency for repair:

- * The Model 510FD Fryer.
- * The Model J4R, 4 oz. Popcorn Machine.
- * The Model 518CMA & 526CMA Cheese Melter.
- * The Model 12MC & 15MC & 18MCP Hot Food Merchandisers.
- * The Model 12NCPW & 15NCPW Nacho Chip/Popcorn Warmer.
- * All Hot Dog Equipment **except Roller Grills & Drawer Bun Warmers.**
- * All Nacho Cheese Warmers **except Model 11WLA Series Nacho Cheese Warmer.**
- * All Condiment Dispensers **except the Model HPDE, & SPDE Series Dispenser.**
- * All Specialty Food Warmers **except Model 130R, 11RW Series, and 11WSA Series.**
- * All QCS/RCS Series Toasters **except Model QCS3 & RCS3 Series.**

ALL:

- * Pop-Up Toasters
- * Butter Dispensers
- * Pretzel Merchandisers
- * Pastry Display Cabinets
- * Nacho Chip Merchandisers
- * Accessories of any kind
- * Sneeze Guards
- * Pizza Ovens
- * Heat Lamps
- * Pumps

The foregoing warranty is in lieu of any and all other warranties expressed or implied and constitutes the entire warranty.

FOR ASSISTANCE

Should you need any assistance regarding the Operation or Maintenance of any Star equipment; write, phone, fax or email our Service Department. In all correspondence mention the Model number and the Serial number of your unit, and the voltage or type of gas you are using.

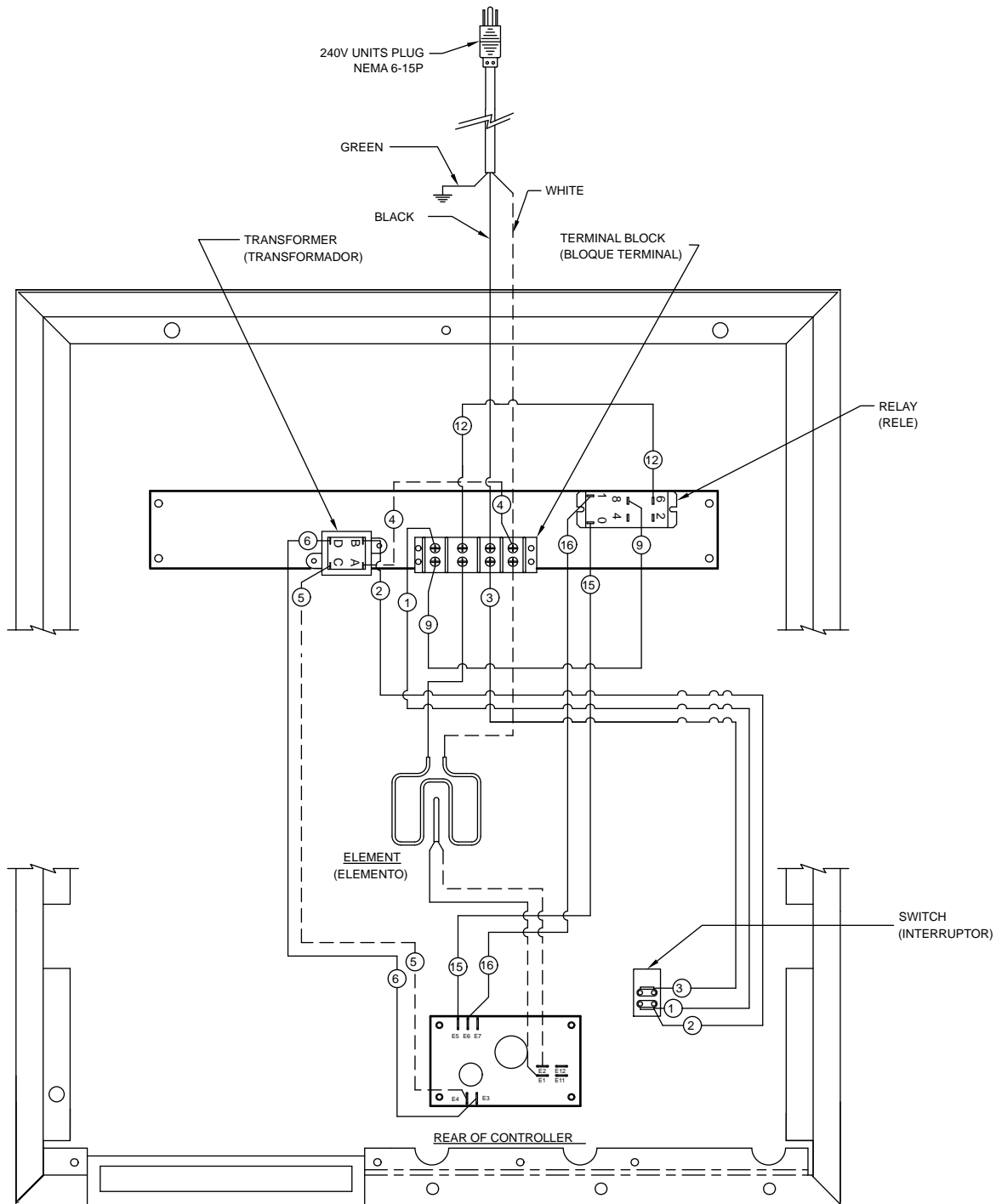

FOR REFERENCE

WIRING DIAGRAM IS SHOWN AS UNIT IS ASSEMBLED WITH THE BOTTOM PLATE REMOVED. THE TOP DESCRIPTIONS ARE THEIR POSITIONS WHEN UPRIGHT.

**WIRE DIAGRAM, 240V, 2150 WATT
(D9-Z11369 CONTROLLER ONLY)**



MODEL: EG14PB-240V

STAR MANUFACTURING INTERNATIONAL, INC.

SK2343

REV. -

01/15/08

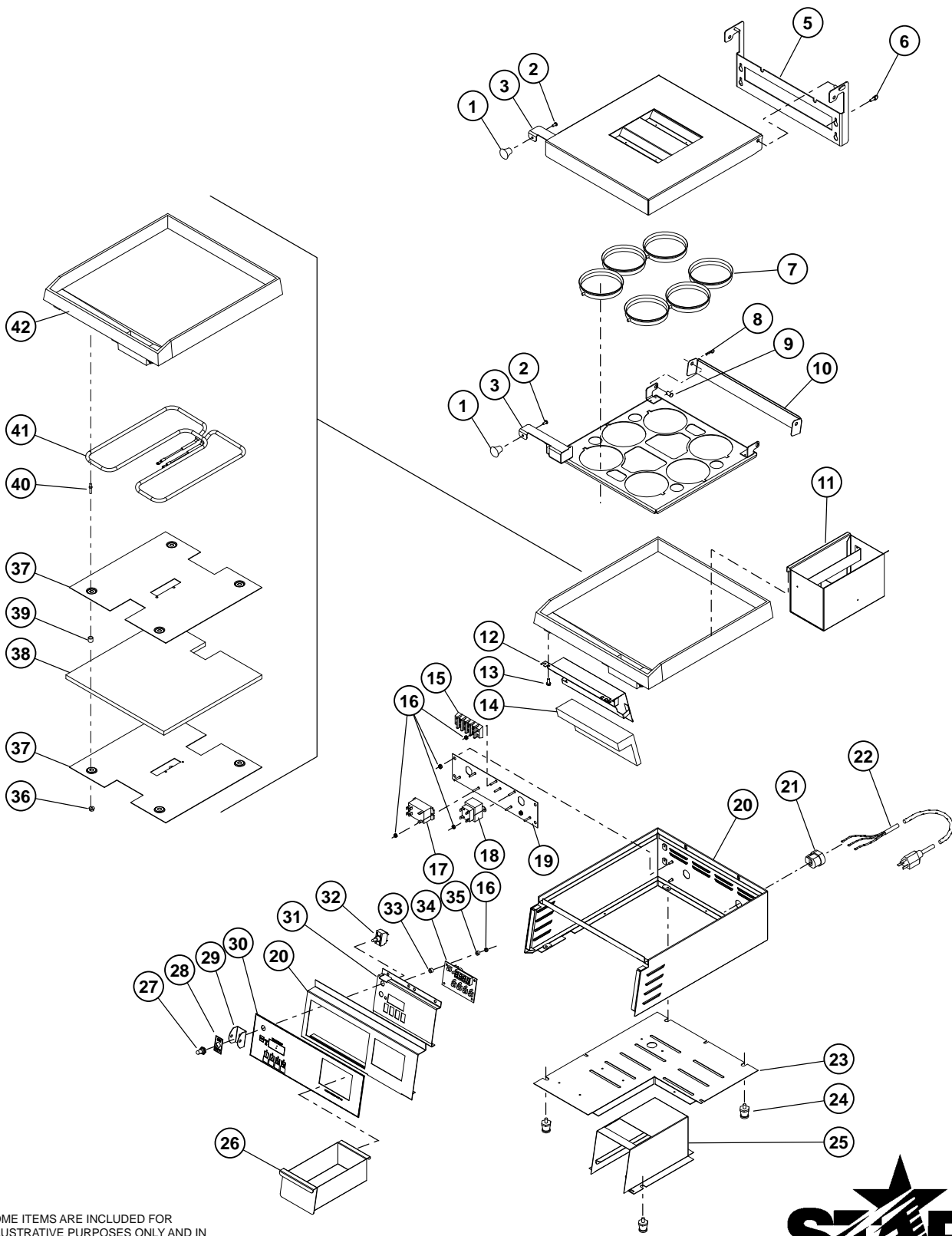

SOME ITEMS ARE INCLUDED FOR ILLUSTRATIVE PURPOSES ONLY AND IN CERTAIN INSTANCES MAY NOT BE AVAILABLE

This drawing contains information confidential to Star Manufacturing International, Inc. No reproduction or disclosure of its contents is permitted.



MODEL: EC14PB-240V

STAR MANUFACTURING INTERNATIONAL, INC.

SK2345

REV. -

1/28/08

PARTS LIST

June 2, 2008, Rev -

MODEL: EC14PB-240V Egg Cooker

| Key Number | Part Number | Number Per Unit | Description |
|------------|---------------|-----------------|-----------------------------|
| 1 | 2R-Z0872 | 2 | KNOB, DAVIES #3004-S |
| 2 | 2C-20115-05 | 2 | SCRW S/S 8-32X3/8 P/H S/T |
| 3 | D9-GR0397 | 1 | COVER ASSY EGG GRILL |
| 4 | D9-GR0398 | 1 | RING HOLDER ASSY EGG GRL |
| 5 | D9-GR0403 | 1 | BACK BRACKET ASSEMBLY |
| 6 | 2C-Z11368 | 4 | THUMB SCRW 10-24 SPDHD SS |
| 7 | D9-GR0399 | 6 | 4" EGG RING ASSEMBLY |
| 8 | 2C-Z10215 | 2 | COTTER PIN 18-8 5/16 .059 |
| 9 | 2A-Z9992 | 2 | HINGE PIN, OUTSIDE |
| 10 | D9-Z11356 | 1 | BAFFLE |
| 11 | D9-GR0402 | 1 | SIDE CAR ASSEMBLY |
| 12 | D9-Z11677 | 1 | INSULATION BAFFLE |
| 13 | 2C-Z5883 | 4 | 10-24 X 1/2 FZA SCREW |
| 14 | D9-Z3826 | 1 | INSULATION - BAFFLE |
| 15 | 2E-Z2894 | 1 | TERMINAL BLOCK (304) |
| 16 | 2C-Z2594 | 9 | NUT 6-32 HEX W STL NP |
| 17 | 2E-Z3335 | 1 | RELAY DBL POLE-SNGL THROW |
| 18 | 2E-05-07-0350 | 1 | TRANSFORMER 230V/10V 6VA |
| 19 | D9-GR0156 | 1 | REAR PLATE ASSY. |
| 20 | D9-GR0395 | 1 | BODY ASSEMBLY - EGG GRILL |
| 21 | 2K-Y6764 | 1 | BUSHING - STRAIN RELIEF |
| 22 | D9-GR0194 | 1 | POWER CORD ASSY. |
| 23 | D9-Z3259 | 1 | BASE BOTTOM |
| 24 | 2A-Z1485 | 4 | FOOT 1" ADJUSTABLE |
| 25 | D9-GR0150 | 1 | GREASE CABINET ASSY. |
| 26 | D9-GR0157 | 1 | GREASE DRAWER ASSY. |
| 27 | 2I-05-07-0013 | 1 | BOOT SWITCH |
| 28 | 2M-12-07-0038 | 1 | LABEL ON & OFF |
| 29 | Z1-70-07-0343 | 1 | SWITCH GUARD |
| 30 | 2M-Z11354 | 1 | OVERLAY 14SG SINGEL E/C |
| 31 | D9-GR0400 | 1 | FACEPLATE ASSY - EGG CKR |
| 32 | 2E-Z3808 | 1 | SWITCH(EATON)-30A@120V |
| 33 | 2K-Z1971 | 4 | SPACER .257X.75X.25 NYLON |
| 34 | D9-GR0410 | 1 | CONTROL BOARD EGG COOKER |
| 35 | 2K-08-07-0004 | 4 | SPACER ROUND NYLON |
| 36 | 2C-Z2893 | 4 | NUT 10-24 HEX STL ZP |
| 37 | D9-Z8082 | 2 | ELEM & INS PLATE BTM 14 |
| 38 | D9-Z2888 | 1 | INSULATION - 14" |
| 39 | 2A-Z6604 | 4 | SPACER - INSULATION PLATE |
| 40 | 2C-08-07-0285 | 4 | SCREW 10-24X3/4X3/8 TYPE ~ |
| 41 | 2N-Z9520 | 1 | ELEMENT,2150WATT 240V-14B C |
| 42 | D9-GR0077 | 1 | CASTING BOTTOM ASSY |
| NI | 2E-Z3278 | 1 | RTD PROBE - 48" LONG WIRE A |

**IMPORTANT: WHEN ORDERING, SPECIFY VOLTAGE OR TYPE GAS DESIRED
INCLUDE MODEL AND SERIAL NUMBER**

PAGE 1
OF 2

Some items are included for illustrative purposes only and in certain instances may not be available.



Star Manufacturing International, Inc.