



**COOKING  
EQUIPMENT**

**OPERATOR'S MANUAL  
HOLMAN CONVEYOR TOASTERS**

**OVEREASY MODEL EZ10**

**FOR SERVICE INFORMATION**

**U.S. AND CANADA CALL: TOLL FREE 1-800-225-3958  
24 HOURS/DAY 7 DAYS/WEEK**

**TABLE OF CONTENTS**

UNCRATING AND INSPECTION	PAGE 1
ASSEMBLY AND INSTALLATION	PAGE 1
FRONT BEARING ASSEMBLY	PAGE 1a
COOKING PROCEDURES	PAGE 2
CLEANING PROCEDURES	PAGE 3
TROUBLESHOOTING GUIDE	PAGE 4, 5
MAINTENANCE PROCEDURES	PAGE 5, 6
PARTS LIST	PAGE 7

**DRAWINGS**

OPTIONAL FEED TRAY	PAGE 3
DRIVE SYSTEM	PAGE 4
HEATER TUBE INSTALLATION	PAGE 5
COMPONENT ARRANGEMENT	PAGE 7
HEAT REFLECTOR/CRUMB TRAY	PAGE 7
WIRING DIAGRAM	PAGE 8
REINSTALLING TOP COVER	PAGE 9

**OPERATOR'S MANUAL  
HOLMAN CONVEYOR TOASTERS  
OVEREASY MODEL EZ10**

**UNCRATING AND INSPECTION**

Unpack unit and components from container. Remove all visible packing material, inspect unit for damage. If damage is discovered, file a claim immediately with the carrier that handled the shipment.

**ASSEMBLY AND INSTALLATION**

The unit has been shipped fully assembled and ready to plug into a standard 15 amp outlet. Removal or replacement of the power supply cord and plug will result in the voiding of the warranty. For assistance, consult with the factory service team at 1-800-225-3958.

FIG. 1 PLUG CONFIGURATION

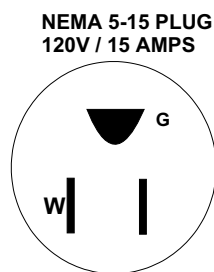

**WARNING:** MAKE SURE ALL INPUT POWER IS **OFF** BEFORE INSTALLING/REMOVING ANY PARTS.

**WARNING:** BE ABSOLUTELY SURE THE GROUND CONNECTION FOR THE RECEPTACLE IS PROPERLY WIRED. NEVER CONNECT UNIT TO POWER WITHOUT PROPER GROUND CONNECTIONS. IMPROPER GROUND MAY RESULT IN SEVERE INJURY OR FATALITY.

REVISED 4/18/95 MJC

## MODEL EZ10

### SPRING LOADED FRONT BEARING ASSEMBLY

Your Holman Conveyor Toaster is equipped with a spring-loaded front bearing assembly as shown below in fig. 1. The spring-loaded bearing assembly keeps the conveyor belt at a constant tension as the unit heats up and cools down. The conveyor belt is set to the proper tension when the white teflon bushing is flush with the end of the extension as shown in fig. 2.

Fig. 1

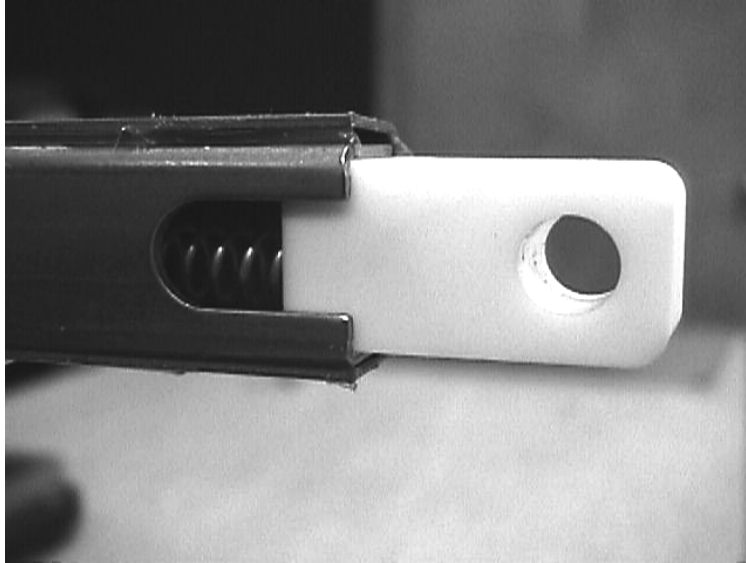
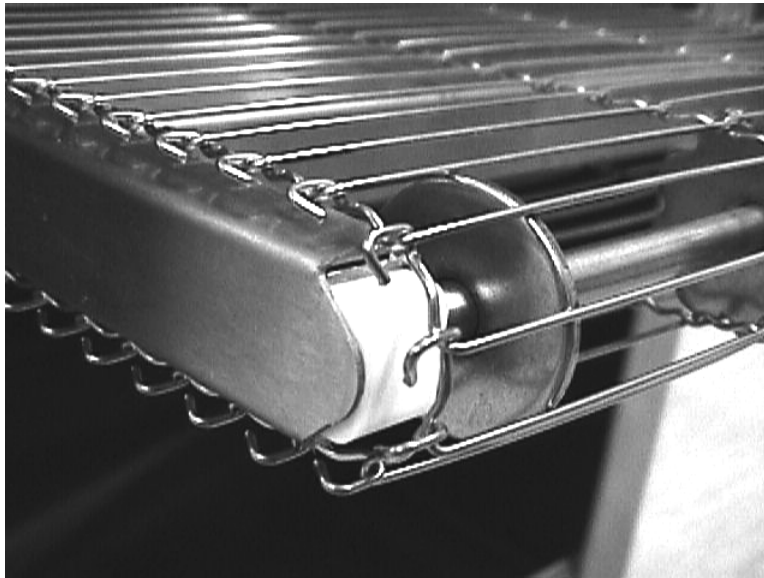

Fig. 2



REVISED 11/30/99 MJC  
EZ10DOC.

## OVEREASY MODEL EZ10

### COOKING PROCEDURES

#### A. BREAD TOASTING

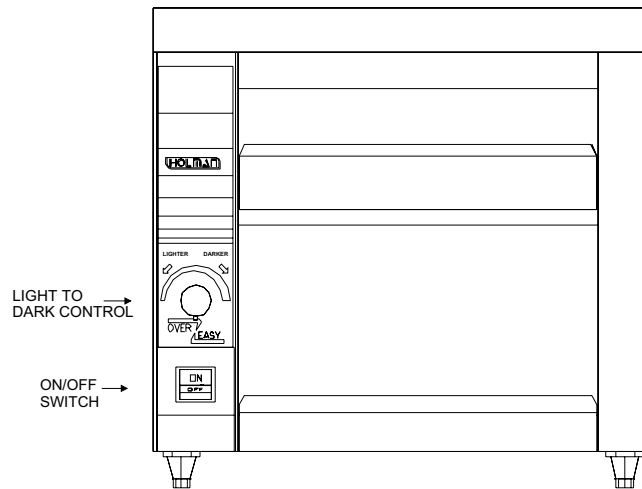

1. Switch On/Off switch control to the ON position; turn light to dark control to the center of the dial.
2. Allow warm up time of 5 to 10 minutes.
3. Test with a slice of bread.
  - a. If toast is too light, turn light to dark control clockwise to a slower speed.
  - b. If toast is too dark, turn light to dark control counterclockwise to a faster speed.

### OPTIONAL FEED TRAY

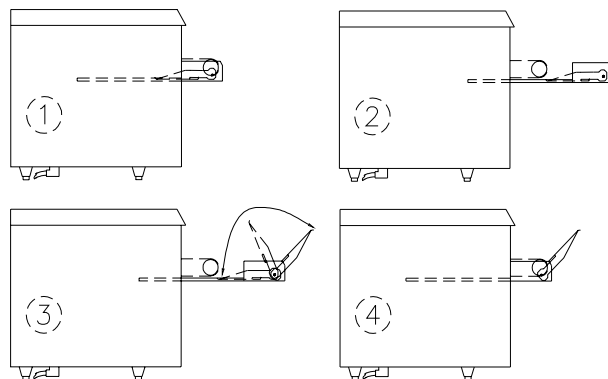

- 1). Optional Feed Tray is Stored Inside Of Crumb Tray.
- 2). Slide Crumb Tray out To Expose Feed Tray.
- 3). Flip Feed Tray Into Position.
- 4). Slide Crumb Tray Back Into Unit Before Operation.

REVISED 8/31/95 MJC

**HOLMAN CONVEYOR TOASTERS**  
**OVEREASY MODEL EZ10**

**CLEANING PROCEDURES**

1. For lightly soiled conveyor belts, turn conveyor light to dark control to fastest setting and wipe with a damp cloth. For heavily soiled conveyors, turn conveyor light to dark control to fastest setting and wipe with a light abrasive pad.
2. Turn main power switch to the OFF position.
3. After the unit cools, remove interior crumb tray (as shown below) and clean. Slide crumb tray back into position. **DO NOT OPERATE UNIT WITHOUT CRUMB TRAY IN PLACE AS THIS CAUSES OVERHEATING IN THE CONTROL BOX**
4. Wipe exterior surface of unit.

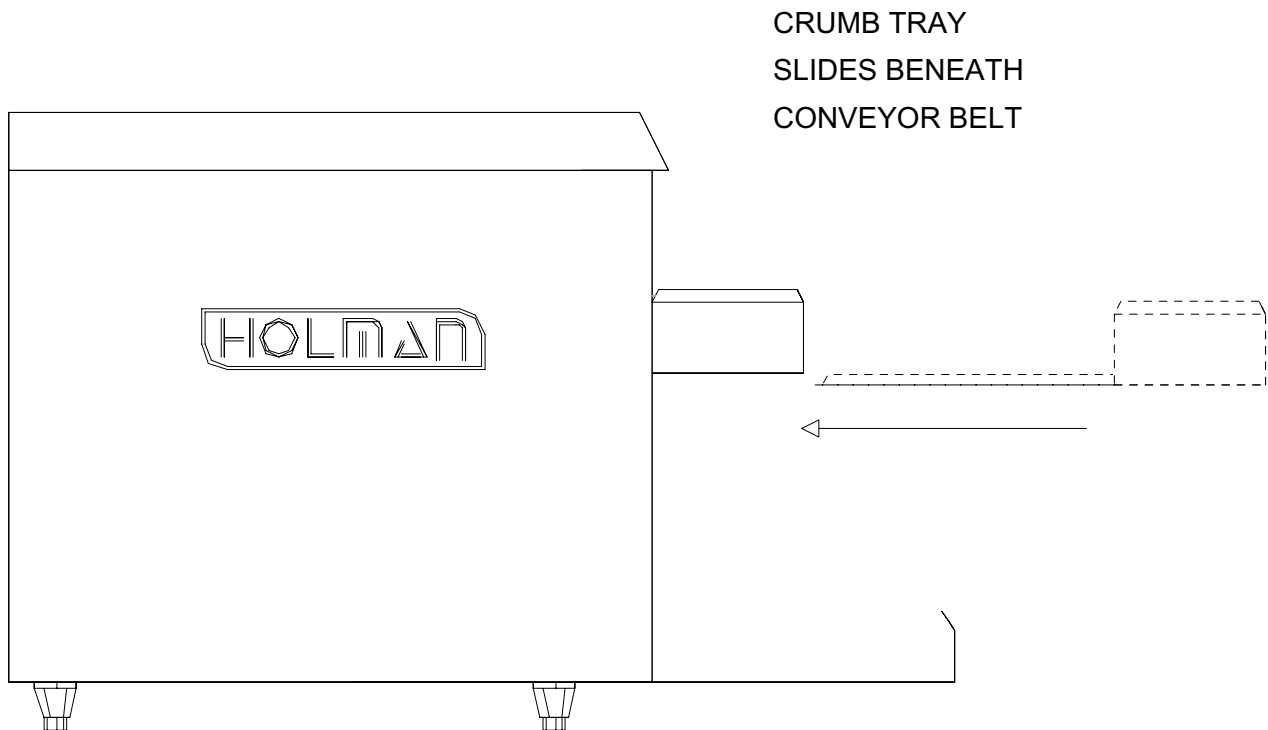

**NOTE: LUBRICATION OF DRIVE CHAIN WITH A GRAPHITE BASED LUBRICANT IS REQUIRED AS PERIODIC MAINTENANCE. CALL HOLMAN FACTORY SERVICE DEPARTMENT FOR DETAILS.**

## TROUBLESHOOTING GUIDE

### A. UNIT WILL NOT HEAT, CONVEYOR BELT WILL NOT MOVE.

1. Be sure the main circuit breaker is switched to the on position.
2. Check to see if the toaster is plugged in and all controls are turned to the **ON** position.

### B. UNIT HAS HEAT ONLY ON ONE SIDE, CONVEYOR BELT TURNS FREELY.

1. Call Holman Factory Service Department at **1-800-225-3958** as heating element may need replacing.

### C. CONVEYOR BELT DOES NOT TURN, HEATER TUBES GET HOT.

To check for mechanical binding:

1. DISCONNECT UNIT FROM POWER SOURCE.
2. Remove screws (2 ea.) holding top cover in place at the rear of the unit.
3. Remove top cover (see page 9).
4. Remove each screw holding side panels in place and lift them up and out.
5. Loosen the four screws which hold the drive motor in place.
6. Slide the motor up allowing the drive chain to be removed from the sprockets.
7. Move the conveyor belt by hand to check for mechanical binding. If conveyor moves freely, call the Holman Factory Service Department at 1-800-225-3958 as the drive motor and/or speed control may need replacing.
8. Refer to page 9 for top cover reinstallation.

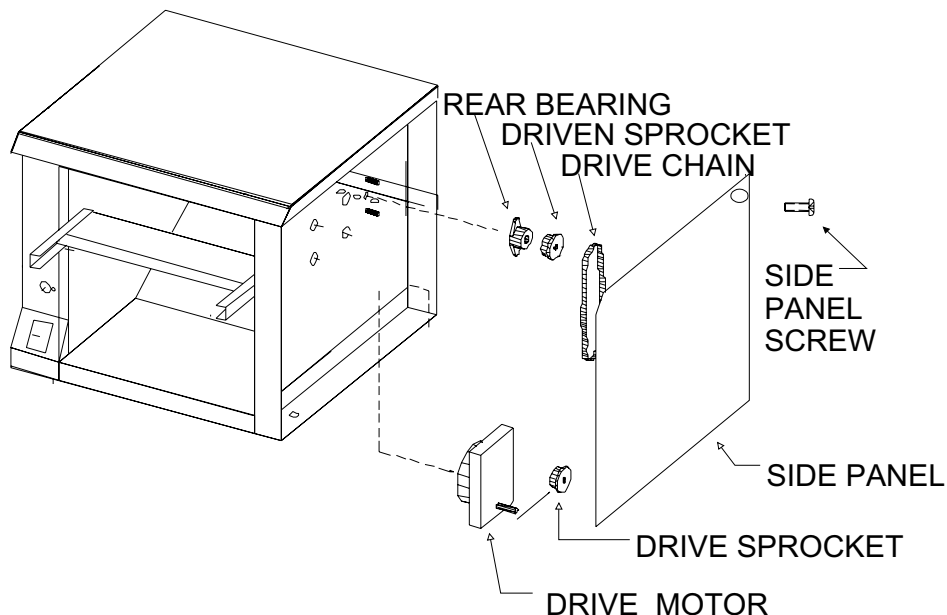

## TROUBLE SHOOTING GUIDE (CON'T)

### D. CONVEYOR BELT RUNS AT ONE SPEED REGARDLESS OF SPEED CONTROL SETTING.

1. Call Holman Factory Service Department at **1-800-225-3958** as speed control should be replaced.

## MAINTENANCE PROCEDURES

### A. CONVEYOR BELT AND DRIVE MOTOR DO NOT REQUIRE LUBRICATION.

### B. REPLACING HEATER TUBES (as below)

1. DISCONNECT UNIT FROM POWER SOURCE.
2. Remove top cover (see page 9).
3. Remove each screw holding side panels in place and lift them up and out.
4. Remove heater tube wire from terminal block connection, keeping top and bottom wires separate.
5. Remove heater tube retainers by removing retaining screws with washer.
6. Gently, pull defective heater tube out of unit.
7. Gently, guide the new heater tube through the same hole the defective heater tube came out through.
8. Replace heater tube retainers, reconnect heater tube wires to terminal block and install side panels.
9. Refer to page 9 for reinstallation of top cover.

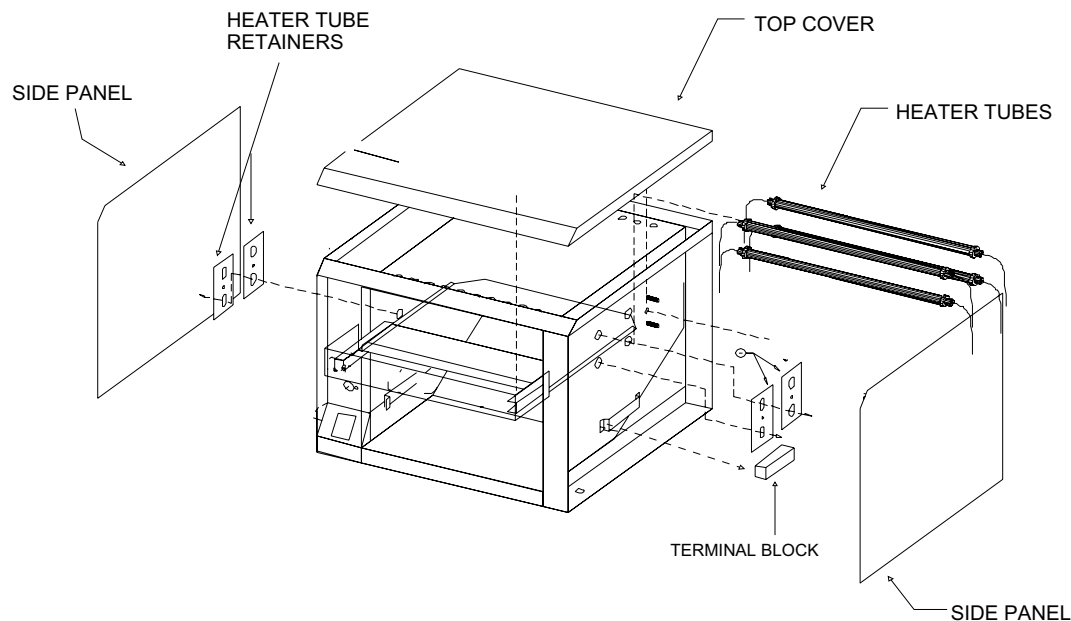

## **MAINTENANCE PROCEDURES (CON'T)**

### **C. REPLACING CONVEYOR BELT DRIVE MOTOR**

1. DISCONNECT UNIT FROM POWER SOURCE.
2. Remove screws (2ea.) holding top cover in place at the rear of the unit.
3. Remove top cover (see page 9).
4. Remove each screw holding side panels in place and lift them up and out.
5. Remove sprocket from motor shaft.
6. Remove the wire from terminal block connecting the drive motor to internal wiring.
7. Remove screws holding motor in place.
8. Put new motor in place and attach loosely with mounting screws.
9. Replace sprocket on motor shaft.
10. Slide motor until the drive chain has about 1/8" slack when lightly pushed at the center of its top open run.
11. Tighten screws to secure motor.
12. Rewire leads same as removed in step 5.
13. Replace side panel and control box cover.
14. Replace top cover (see page 9).

IF ASSISTANCE IS REQUIRED FOR THIS OR ANY OTHER PROCEDURE IN THIS MANUAL CALL HOLMAN FACTORY SERVICE DEPARTMENT AT **1-800-225-3958**.  
**24 HOURS/DAY 7 DAYS/WEEK**

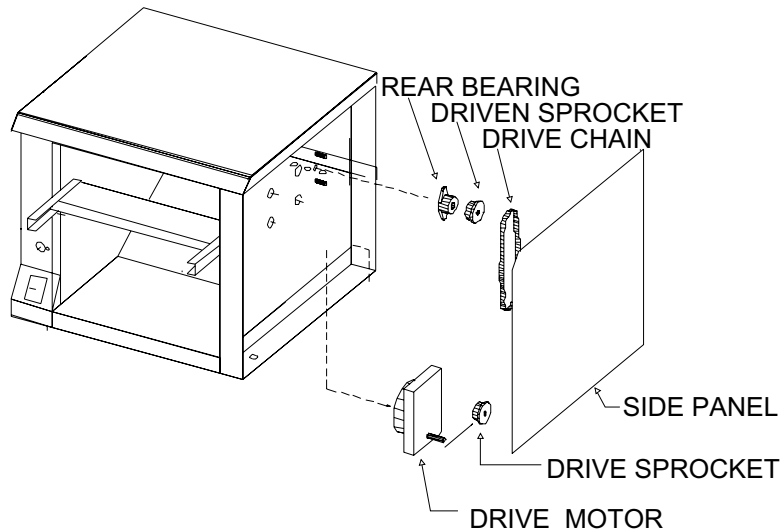

**LUBRICATION OF DRIVE CHAIN WITH A GRAPHITE BASED LUBRICANT IS REQUIRED AS PERIODIC MAINTENANCE. CALL HOLMAN FACTORY SERVICE DEPARTMENT FOR DETAILS.**



## INSTRUCTIONS FOR REINSTALLING THE TOP COVER ON THE OVEREASY

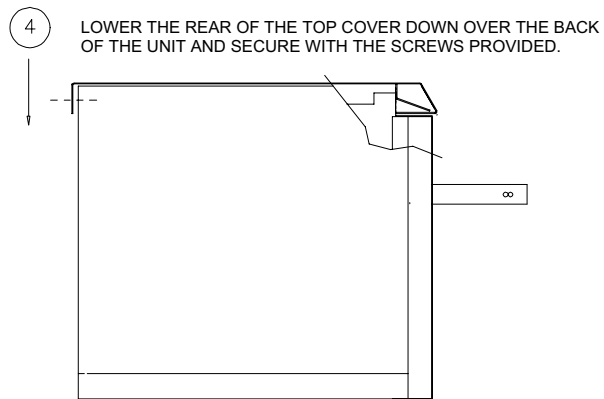
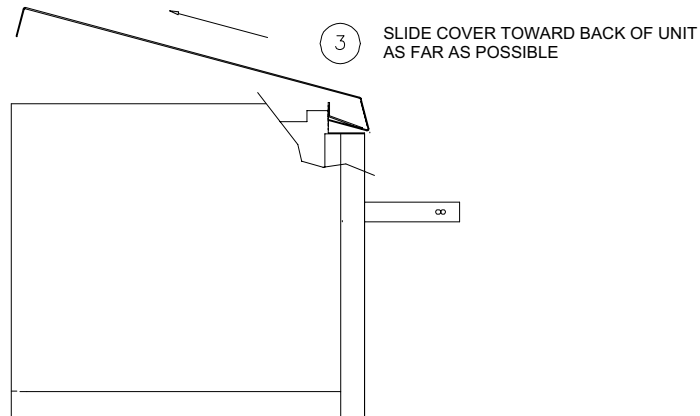
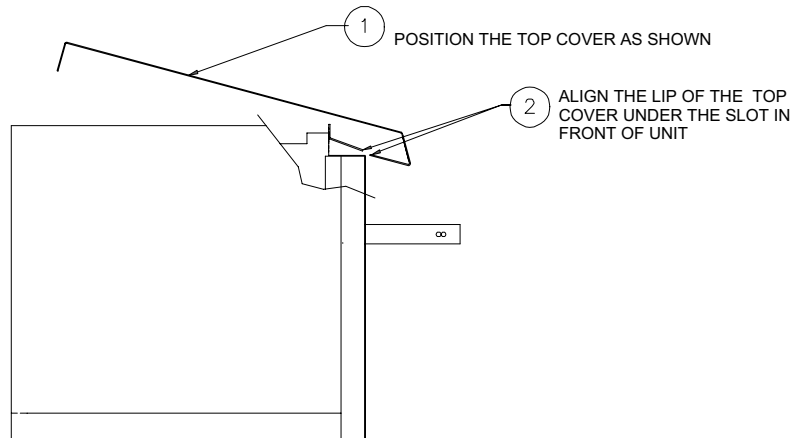

# WIRING DIAGRAM FOR MODEL EZ10 120 VOLT, 60Hz SINGLE PHASE

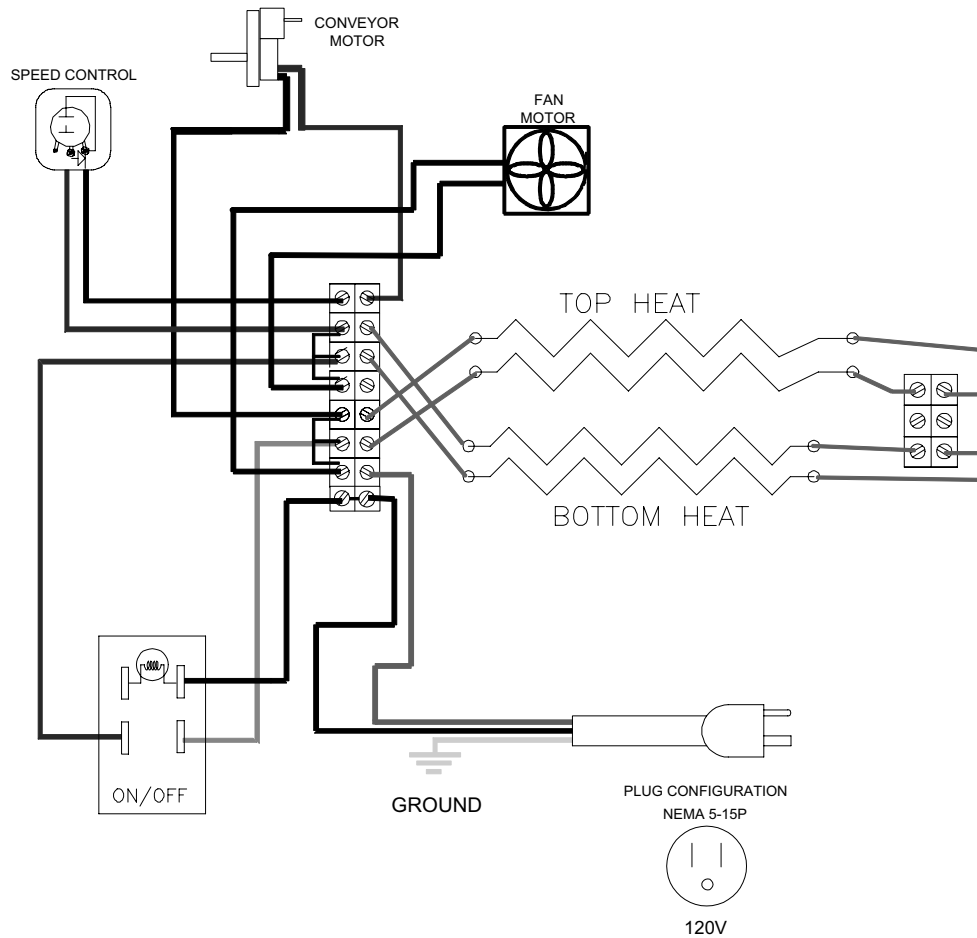

REV. 11/15/99

REV.12/1/99 MJC

PAGE 8

OPERATOR'S MANUAL  
HOLMAN CONVEYOR TOASTERS  
MODEL EZ10

# EZ10 120 VOLT WITH FAN MOTOR

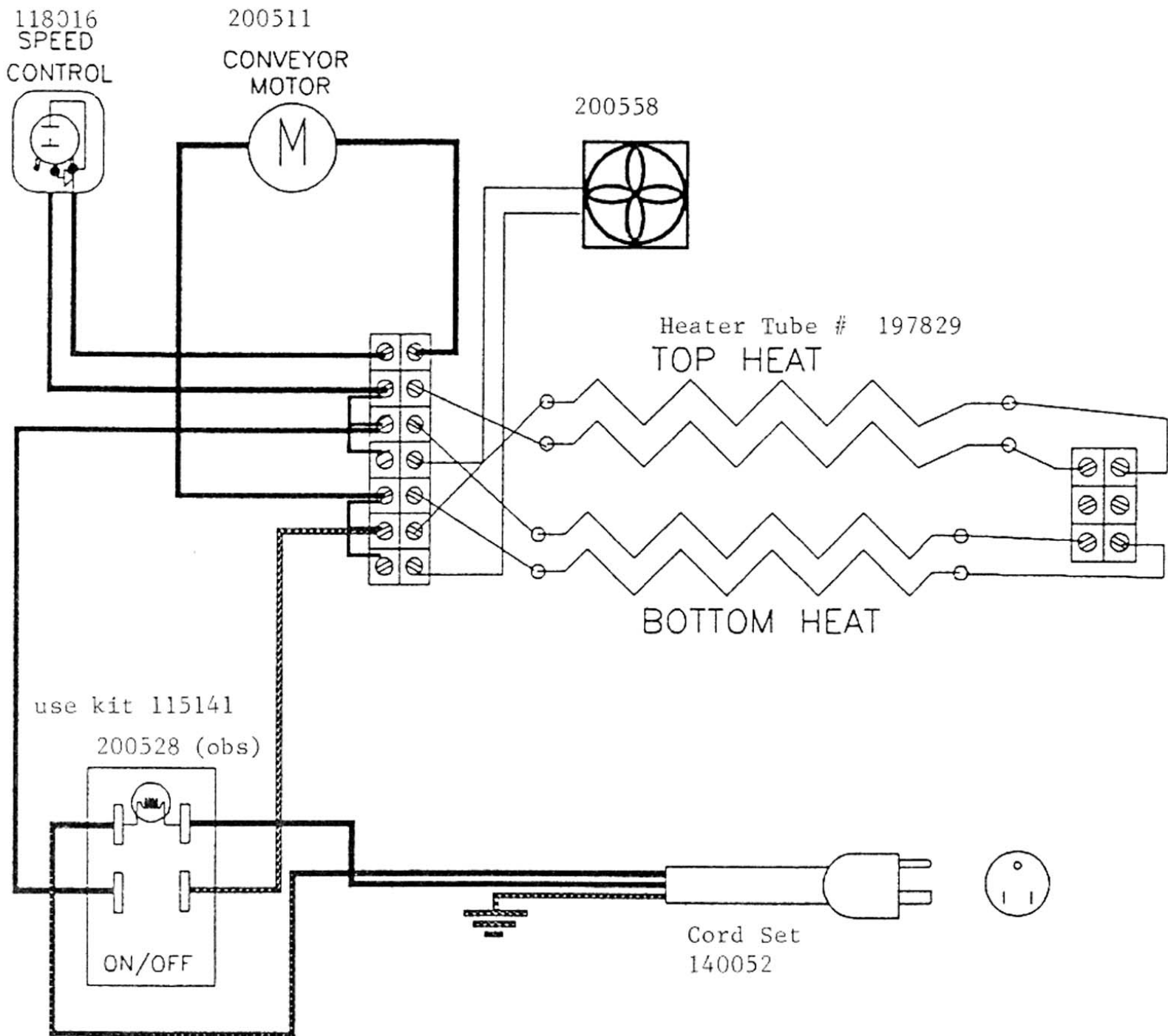

OPERATOR'S MANUAL  
HOLMAN CONVEYOR TOASTERS  
OVEREASY MODEL EZ10

# WIRING DIAGRAM

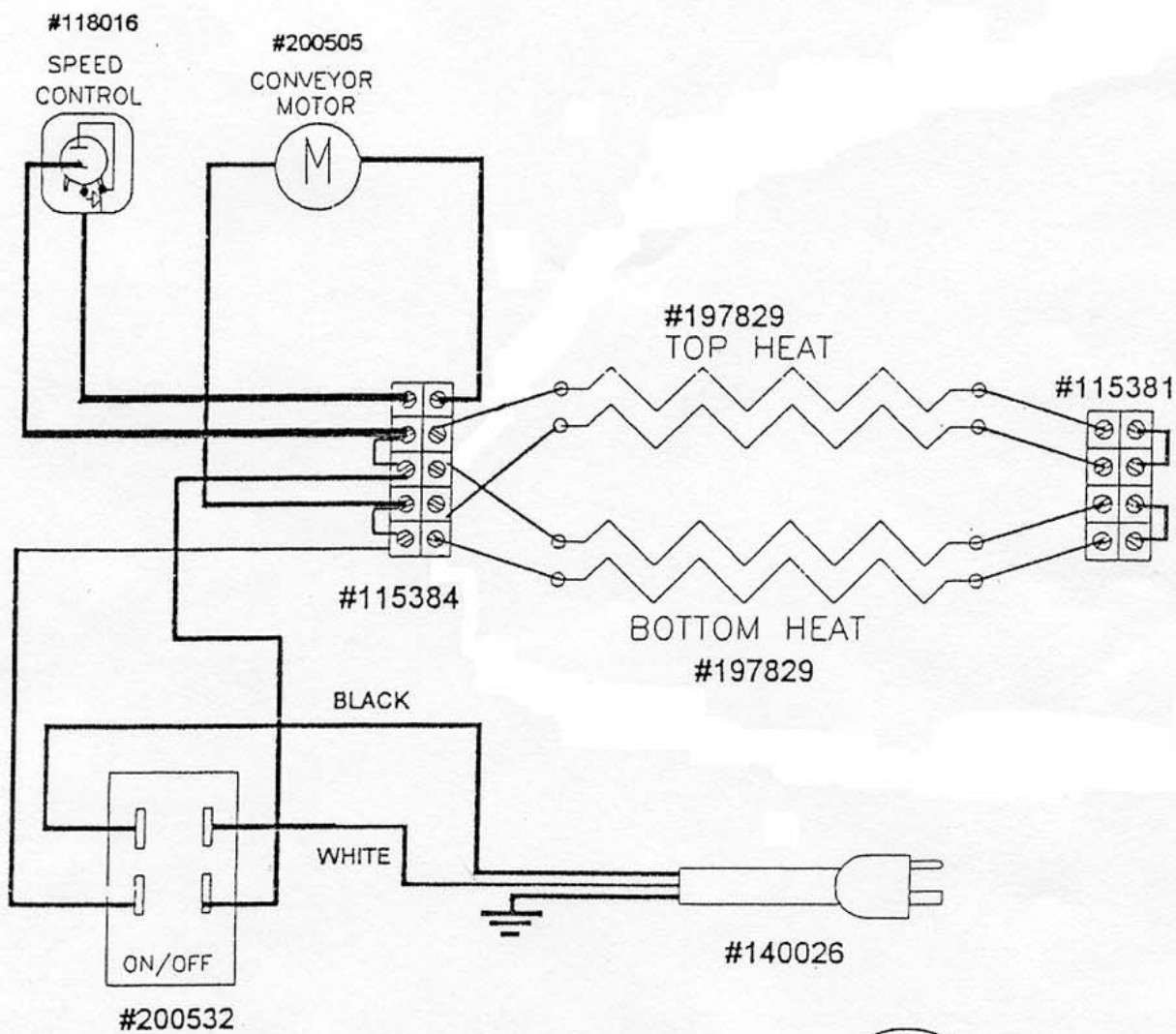

NEMA 5-15 P  
120 / 15AMP



#010533

MODEL EZ10 220 VOLT 50/60 Hz

H:\Y2KWDIAG\010533

ALSO USED AS 010534 & 010535

REV	DESCRIPTION	DATE	CHECKED	APPROVED
X	X	X	X	X

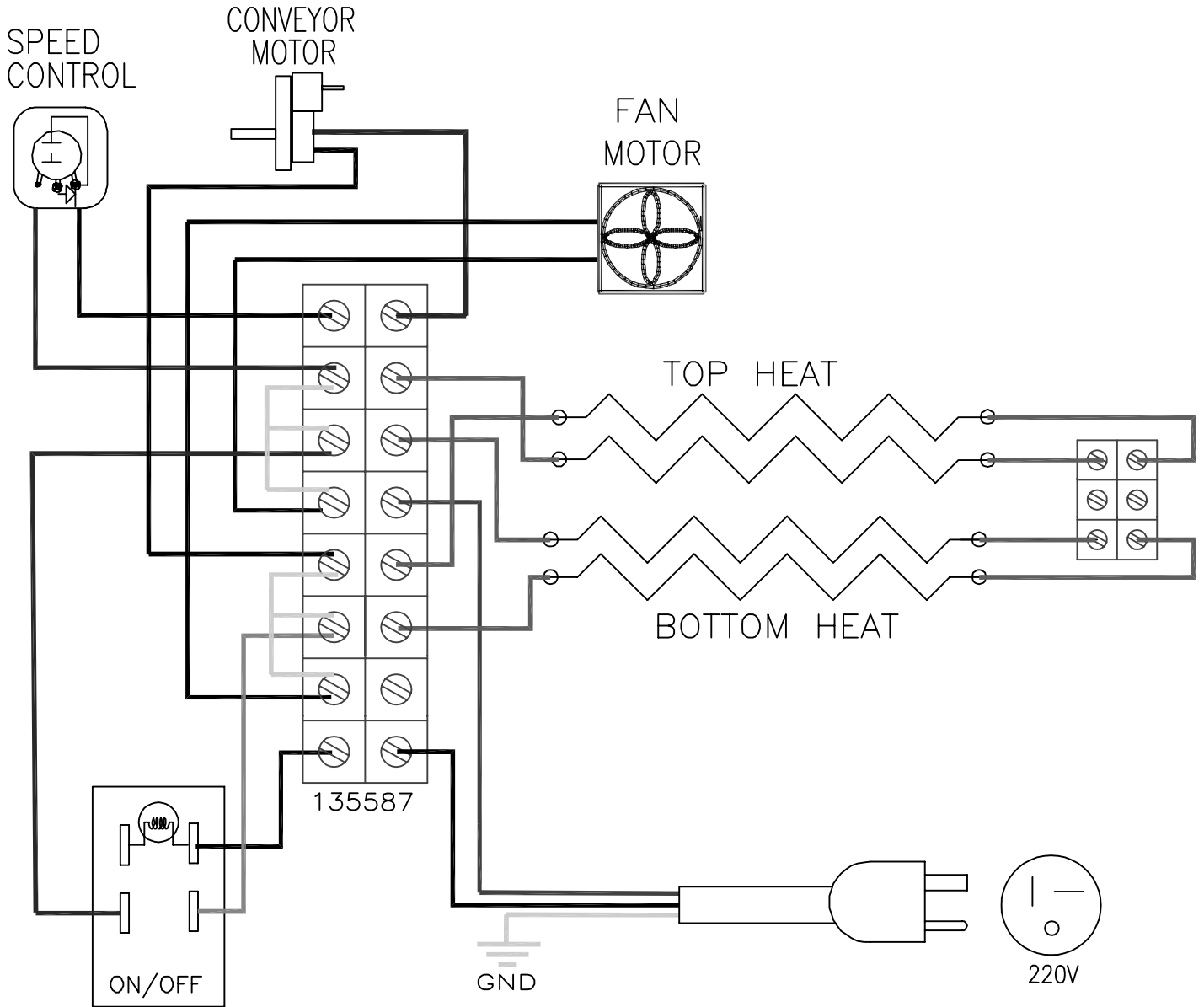

MASTER COPY APPROVED BY:

ENG. \_\_\_\_\_ DATE \_\_\_\_\_

QUAL. \_\_\_\_\_ DATE \_\_\_\_\_

PROD. \_\_\_\_\_ DATE \_\_\_\_\_



Holman Cooking Equipment, Inc.  
90 Industrial Park Road  
P.O. Box 880  
Saco, Maine 04072  
Phone # (207)-282-1589

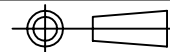

Third Angle Projection

All dimensions in decimal inches

All angles 90°, unless specified  
All angles +/- 1°

Tolerance	.X	+/-	.060
	.XX	+/-	.030
	.XXX	+/-	.015

Drawn by: S.Macomber

Date: 4/3/00

Part Description:

WIRE DIAGRAM  
EZ10 220 VOLT

Size A Finish -----

Approved By: G.Cole

Date: 4/3/00

Part No. 010533

Scale: FULL

Sheet 1 of 1

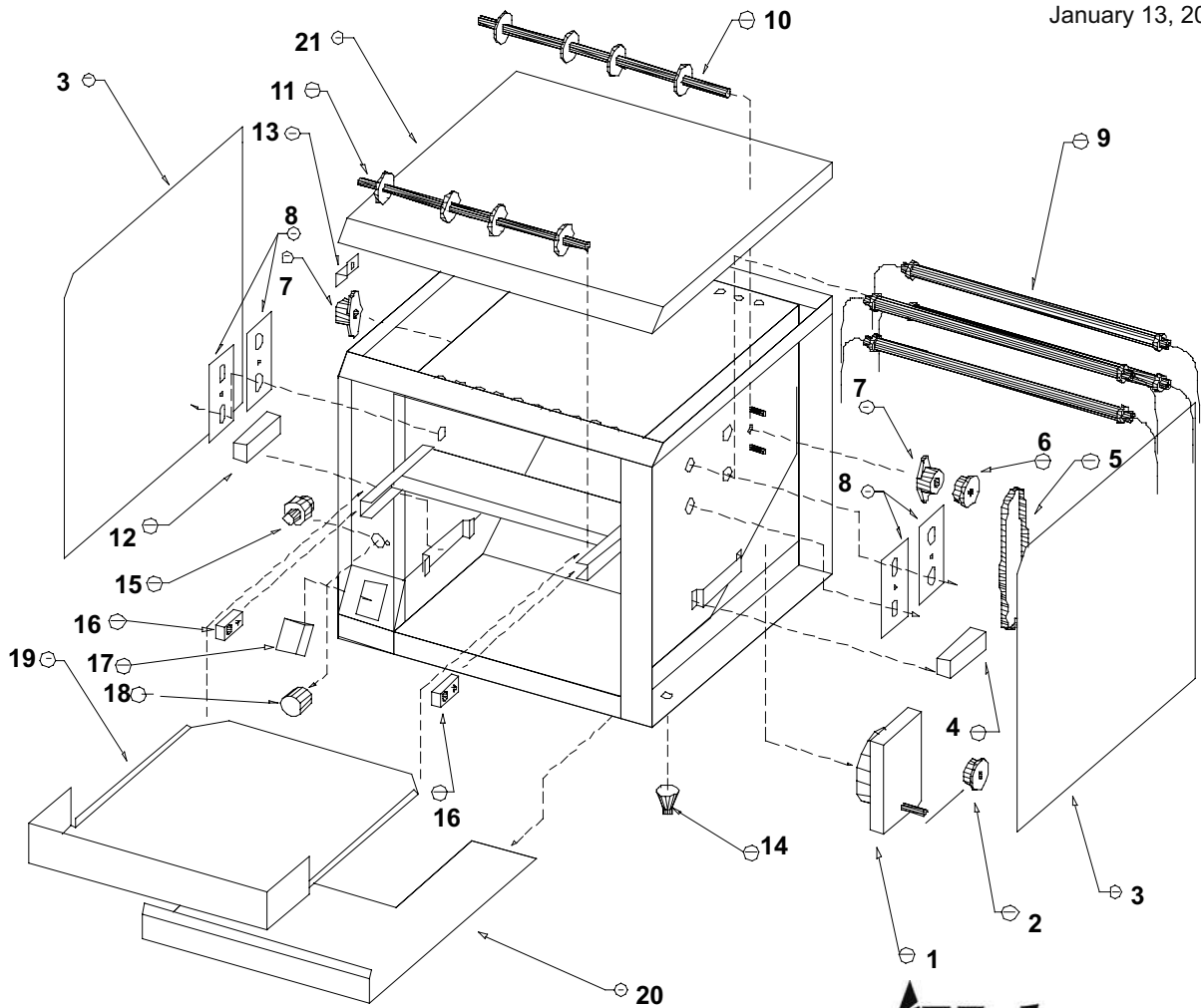

Model: EZ10



Fig No	Part No	Qty	Description
1	2U-200511	1	MOTOR, 2020 BB REVERSED, <i>FAN BLADE NOT INCLUDED</i>
NI	2R-200721	1	FAN BLADE
2	2P-200645	1	SPROCKET, 25B17 X 5/16
3	HN-401566	3	PANEL, SIDE & BACK, EZ10
4	HA-115383	1	BLOCK, TERMINAL 3 POS, SM
5	2P-200665	1	CHAIN, 17 1/2 INCH HN-115140
6	2P-200645	1	SPROCKET, 25B17 X 5/16
7	HA-112261	2	BEARING ASSY PTFE/BRONZE
8	HN-401917	1	UNIVERSAL RETAINER PLATE
9	HE-197829	4	HEATER TUBE, EZ10, QCS-2-800
	HA-197832	4	ELEMENT, EZ10, 220V
10	2A-202900	1	SHAFT, T710 DRIVE
11	2A-202904	1	SHAFT, 210HX IDLER
12	HB-115387	1	BLOCK, TERMINAL 8 POS, SM
13	2P-200736	2	2 INCH BEARING SPRING
14	2R-200709	4	LEG 1 INCH CHROME PLASTIC
15	HN-118016	1	CONT SPEED ASSY 250 EZ10
16	2P-200700	2	SPRING LOAD BEARING TEFLON
17	HN-115140	1	RETRO FIT, TOGGLE EZ10
18	2R-200703	1	KNOB, POTENTIOMETER
19	HN-100540	1	TRAY, CRUMB LOADUP COMBO
20	HN-401554	1	SLIDE, TOAST, PULL OUT, EZ10
21	HN-401573	1	TOP COVER, EZ10
22	HA-140026	1	CORD SET, VA, T710 120
23	HN-160020	1	BELT, CONVEYOR 10 X 27 EZ
24	2U-200558	1	MOTOR, FAN 120V, 15BTL

120V, 240V  
220V