

*Pro-Max® Pro-Max® Pro-Max® Pro-Max® Pro-Max®*

# ***Pro-Max***<sup>®</sup>

## **TABLE TOP TWO SIDED TOASTER**

MODEL  
GR10T4K-UK, GR10T4K-CE

### **Installation and Operation Instructions**

2M-Z9364 Rev.A 1/31/2011



## SAFETY SYMBOL



These symbols are intended to alert the user to the presence of important operating and maintenance instructions in the manual accompanying the appliance.

---

## RETAIN THIS MANUAL FOR FUTURE REFERENCE NOTICE

Using any part other than genuine Star factory supplied parts relieves the manufacturer of all liability.

Star reserves the right to change specifications and product design without notice. Such revisions do not entitle the buyer to corresponding changes, improvements, additions or replacements for previously purchased equipment.

Due to periodic changes in designs, methods, procedures, policies and regulations, the specifications contained in this sheet are subject to change without notice. While Star Manufacturing exercises good faith efforts to provide information that is accurate, we are not responsible for errors or omissions in information provided or conclusions reached as a result of using the specifications. By using the information provided, the user assumes all risks in connection with such use.

## MAINTENANCE AND REPAIRS

Contact your local dealer for service or required maintenance. Please record the model number, serial number, voltage and purchase date in the area below and have it ready when you call to ensure a faster service.

Model No. \_\_\_\_\_

Serial No. \_\_\_\_\_

Voltage \_\_\_\_\_

Purchase Date \_\_\_\_\_

### FOR SERVICE CONTACT:

**Servequip**

**Telephone:** 011-44-208686-8855

## ELECTRICAL SPECIFICATIONS

Model No.	Volts	Rated Wattage	Amps	Power Inlet
GR10T4K-UK	230	1653	7.2	IEC320 C20 Power inlet

### GENERAL INSTALLATION DATA



#### CAUTION

This equipment is designed and sold for commercial use only by personnel trained and experienced in its operation and is not sold for consumer use in and around the home nor for use directly by the general public in food service locations.

All shipping containers should be checked for freight damage both visible and concealed. This unit has been tested and carefully packaged to insure delivery of your unit in perfect condition. If equipment is received in damaged condition, either apparent or concealed, a claim must be made with the delivering carrier.

Concealed damage or loss - if damage or loss is not apparent until after equipment is unpacked, a request for inspection of concealed damage must be made with carrier within 15 days. Be certain to retain all contents plus external and internal packaging materials for inspection. The carrier will make an inspection and will supply necessary claim forms.

#### VENTILATION AND CLEARANCES

The installation of any components such as a vent hood, grease extractors, and/or fire extinguishing systems, must conform to their applicable nationally recognized installation standards and/or local building codes.

### ELECTRICAL CONNECTION



#### CAUTION

Before making any electrical connection be sure to read the data plate located at the bottom of the unit.



#### CAUTION

**CONNECT/PLUG UNIT INTO DEDICATED A.C. LINE ONLY SPECIFIED ON THE DATA PLATE OF THE UNIT.**

### ELECTRICAL GROUNDING INSTRUCTIONS



#### CAUTION

This unit is equipped with a 3-prong (grounding) plug for your protection against shock hazard and must be plugged directly into a properly grounded 3-prong receptacle.

**DO NOT CUT OR REMOVE THIS PLUG OR GROUNDING PRONG FROM THE PLUG.**

#### INITIAL START UP

Level unit using the adjustable feet under the unit (approximately 1/2" adjustment).

Unpack the grill and put the owner's manual in a safe place for future reference. Wipe down the exterior and grilling area with a damp cloth. Brush any debris from the grill surfaces.

## SEASONING THE COOKING SURFACES

### FIRST TIME SEASONING

Follow your company/corporate guidelines for seasoning cooking surfaces. or

1. Bring the grill to 300°F and leave it on while doing the next three steps.
2. Brush the cooking surfaces with a release agent. If using an aerosol agent, first apply into a cup and then brush onto cooking surface.
3. Let sit for 20 minutes, and then wipe clean using a warm damp cloth.

### DAILY SEASONING

The grill should not require much seasoning while in use. In most cases, brush a light coating of the baking release agent in the morning and occasionally throughout the day will be enough to prevent any sticking. It is not necessary to spray before grilling each item.



### SETTING THE TEMPERATURE

The thermostat control knob is used to set the temperature to your requirements. The maximum set point is 550°F (288°C), the minimum set point is 175°F (79°C).

Knob Position	Approx. Temp
1-2	175°F / 79°C
3	200°F / 93°C
4	250°F / 121°C
5	300°F / 148°C
6	350°F / 176°C
7	400°F / 204°C
8	450°F / 232°C
9	500°F / 260°C
10	550°F / 287°C

### PROGRAMMING THE TIMER

The timer may be factory pre-set. If changes are required follow these steps:

1. Press and hold the PGM button located on the left side of the display.
2. Press and hold one of the buttons (1 through 4) that needs to be programmed. After approximately 1 second, the display window will show " \_ \_ \_ ." When this is displayed, let go of the buttons.
3. Enter the 3-digit security code. As the digits are entered, the corresponding horizontal bar will move from the bottom to the center. The security code will not be displayed. Once the correct security code is entered, the display will be the current time of the selected button.
4. Change the time by pressing and holding the  button to increase the time or the  button to decrease the time.
5. Once the correct time is displayed, press the PGM button to save the time.
6. One can now change the time by pressing another button and repeating steps 3 and 4.
7. When programming is complete, exit the programming mode by not pressing any buttons for 15 seconds.

## ON/OFF TOGGLE SWITCH

The switch turns the unit on and off. The switch has three positions:



With the switch in this position, both top and bottom platens will heat.



With the switch in this position, neither platen will heat; the unit is OFF.



With the switch in this position only the bottom platen will heat.

## DAILY OPERATION

**Make sure the unit is plugged into a 15 amp, 230V receptacle.**

1. Turn the electrical power of the unit ON by placing the switch in either the up or down position. **IMPORTANT:** The heat will not start until the thermostat is also turned to the heating position, approximately 2 or higher on the dial.
2. To start heating, turn the temperature knob to the desired setting. Initial start-up heating time is approximately 30 minutes.
3. Place product(s) on the bottom cooking surface.
4. Close the lid if the top is also ON. If the top is OFF, the unit can be operated similar to a griddle.
5. Press the desired button (1 through 4) on the timer. The timer countdown will begin regardless of what button is pressed.
6. When the countdown reaches 0:00, the display will flash and the unit will beep. To turn off the beeping, press the same button (1 through 4) used to start the countdown.  
NOTE: If one wants to end a countdown, the same button (1 through 4) can be pressed at any time in the countdown cycle. The display will return to the programmed time for that button.
7. Raise the lid to the open position and remove the product(s).
8. For best performance, keep the lid closed when products are not being cooked.

## OPERATING HINTS AND SAFETY

Disconnect power to the unit with the switch at the end of each day of operation. Do not leave the unit in operation without an attendant.

Turn the thermostat down to 200°F (93°C) during idle periods. It will take only a few minutes to regain operating temperature. Use a spatula to push excess grease into the grease drawer after each load of food is cooked. This will reduce smoking of hot grease and carbonizing.

Do not leave the unit at high temperatures when not in use or during idle periods. This will cause food particles and grease film to carbonize.

"Season" cooking surfaces with non-salted vegetable oil to reduce product sticking.

## MONTHLY LUBRICATION/INSPECTION

Apply two (2) drops of non-toxic mineral or vegetable oil to counter balance shoulder rivets and plastic spacers.

Check and clean rollers to make sure they are rolling and not sliding on the cam surfaces of the counterbalance. Check the bolts, screws and nuts; tighten if necessary.

## CLEANING

Begin cleaning procedure by using the operating procedures within your organization, or follow the steps below:

1. If particles adhere to the cooking surface during the day, scrape them off with a spatula.  
**NOTE:** It is best not to let food cook onto the grill, as food build-up on the grill will increase sticking and smoking. In addition, carbon may build up on the grill surface and reduce the cooking efficiency.

**CARBON BUILDUP:** *A black matter that forms on or near the cooking surface. Generally this is a combination of: releasing agents, oils, food particles etc. that has cooked itself to the surface. After a period of time without cleaning, this will reduce performance and material may start flaking off. When that happens, follow the "Carbon Cleaning" procedures.*

2. At the end of the day, wipe down all surfaces with a warm, damp cloth and mild detergent, then dry.

## CARBON CLEANING

When carbon build up occurs, use a carbon removal agent according to the instructions provided with the cleaner. When this process is complete, you must re-season the grill according to your company/corporate guidelines, or the seasoning instructions in this manual.



### CAUTION

**DO NOT IMMERSE OR LET THE UNIT STAND IN WATER.**

**DO NOT HOSE DOWN THE UNIT OR THE TABLE/COUNTER ON WHICH THE UNIT IS LOCATED.**

**KEEP AWAY FROM RUNNING WATER.**



### CAUTION

**DO NOT USE SHARP OBJECTS TO REMOVE CARBON BUILD-UP.**

**BEFORE CLEANING MAKE SURE POWER IS TURNED OFF, UNIT IS UNPLUGGED AND IS NOT TOO HOT.**

While holding top lid with one hand, apply only cleaners which are safe for aluminum and iron surfaces. Wipe with clean sponge or towel until unit is clean.



### CAUTION

**DO NOT SPLASH FRONT CONTROL PANEL!**

**DO NOT SPLASH THE FLEX CONDUIT CONNECTING THE TOP AND BOTTOM OF THE UNIT.**

Remove and empty the grease catcher drawer, to clean using mild detergent and water.



### CAUTION

**Do not use ice or cold water to clean the cooking surfaces when the unit is hot. The surfaces are cast aluminum or cast iron and may crack or deform under the shock of rapid temperature change.**

## **OPERATION TROUBLESHOOTING**

- A. Unit is not heating.
  - 1. Check if the unit is plugged into the correct receptacle.
  - 2. Check the incoming power line.
  - 3. Check that the switch is in the correct position.
  - 4. Check that the thermostat is set to the proper temperature.
- B. The top platen is not heating.
  - 1. Check that the switch is in the correct position.
- C. The counter balance roller is not rolling.
  - 1. Clean the rollers.

**If the unit still does not operate, contact the factory, one of its authorized representatives, or a local service company for service or required maintenance.**

## INTERNATIONAL ONE (1) YEAR EQUIPMENT WARRANTY

All workmanship and materials in “STAR” products are warranted for a period of one year from the date shipped from the factory or one year from the date shown on the proof of purchase of the end-user when purchased through an authorized “STAR” dealer/distributor in a commercial foodservice location.

“STAR’s” obligation under this warranty is limited to the replacement of the defective part(s) only without charge. This warranty is void if damage occurs from improper installation, misuse or abuse, disassembly or tampering of unit for any purpose other than repair by a qualified service agent, wrong voltage, incorrect or fluctuating voltage conditions, wrong gas, improper gas or gas conditions, operated contrary to the installation and operating instructions, operated in an application for which the unit is not suited, or if the unit is not maintained and/or cleaned in a suitable manner.

Any expense in connection with installation, or any cost of making adjustments on a unit to conform to electric or gas service at the point of installation, are not covered by this warranty.

- \* The warranty period for the JetStar series six (6) ounce popcorn machines is two (2) years.
- \* The warranty period for the Chrome-Max Griddles is five (5) years on the griddle surface. See detailed warranty provided with unit.
- \* The warranty period for Teflon/Dura-Tec coatings is one year under normal use and reasonable care. This warranty does not apply if damage occurs to Teflon/Dura-Tec coatings from improper cleaning, maintenance, use of metallic utensils, or abrasive cleaners. This warranty does not apply to the “non-stick” properties of such materials.
- \* This warranty is not valid on Conveyor Ovens **unless** a “start-up/check-out has been performed by a Factory Authorized Technician.

In order to make a claim under this warranty; a warranty report must be filed with Star Manufacturing International Inc. in St. Louis, Missouri, U.S.A. by the dealer/distributor through which product was purchased. All details, including serial number and model number of the defective unit, must be included. Failure to file a claim within a 120 Day time period may result in the claim being refused.

“STAR” may forego the necessity of returning the part for inspection dependent upon the expense involved. However, “STAR” requires defective parts to be held in the claimant’s possession for a period of ninety (90) days for possible inspection by a “STAR” representative or designated inspector .

The foregoing warranty is lieu of any and all other warranties, expressed or implied, and constitutes the entire warranty.

### PARTS WARRANTY

Parts that are sold for out-of-warranty repair are warranted for a period of ninety days. The part only is warranted; no labor.

### SERVICES NOT COVERED BY WARRANTY

1. Labor
2. Mileage and/or travel time
3. Installation and/or adjustment of equipment
4. Operation contrary to the installation and operating instructions
5. Cleaning of equipment
6. Seasoning of griddle plates
7. Voltage conversions/adjustments
8. Gas conversions
9. Pilot light conversion/adjustments
10. Thermostat calibration/adjustments
11. Resetting of circuit breakers or safety controls
12. Replacement of bulbs/lamps
13. Replacement of fuses
14. Damages due to improper installation
15. Damages from abuse or misuse
16. Damage created by acts of God, Acts of War, or Civil Disturbance



**UNITS WITH IEC CONNECTOR:**

**POWER INLET CONNECTOR:**  
IEC 320 C-20 POWER INLET, ON ALL 208 - 240V UNITS.  
FOR USE WITH DETACHABLE CORDSETS SUPPLIED  
WITH A STRAIGHT, FEMALE, IEC 60320 C-19 CONNECTOR.

**NORTH AMERICA:**

**15 AMP PLUG**  
NEMA 5-15P ON 120V, 1,800 WATT UNITS FOR U.S. ONLY.  
NEMA 5-15P ON 120V, 1,400 WATT UNITS FOR U.S. AND CANADA.  
NEMA 6-15P ON ALL 240V, 1,800 WATT UNITS.

**20 AMP PLUG**  
NEMA 6-20P ON ALL 240V, 3,600 WATT UNITS.  
NEMA 5-20P ON 120V, 1,800 WATT UNITS FOR U.S. AND CANADA.

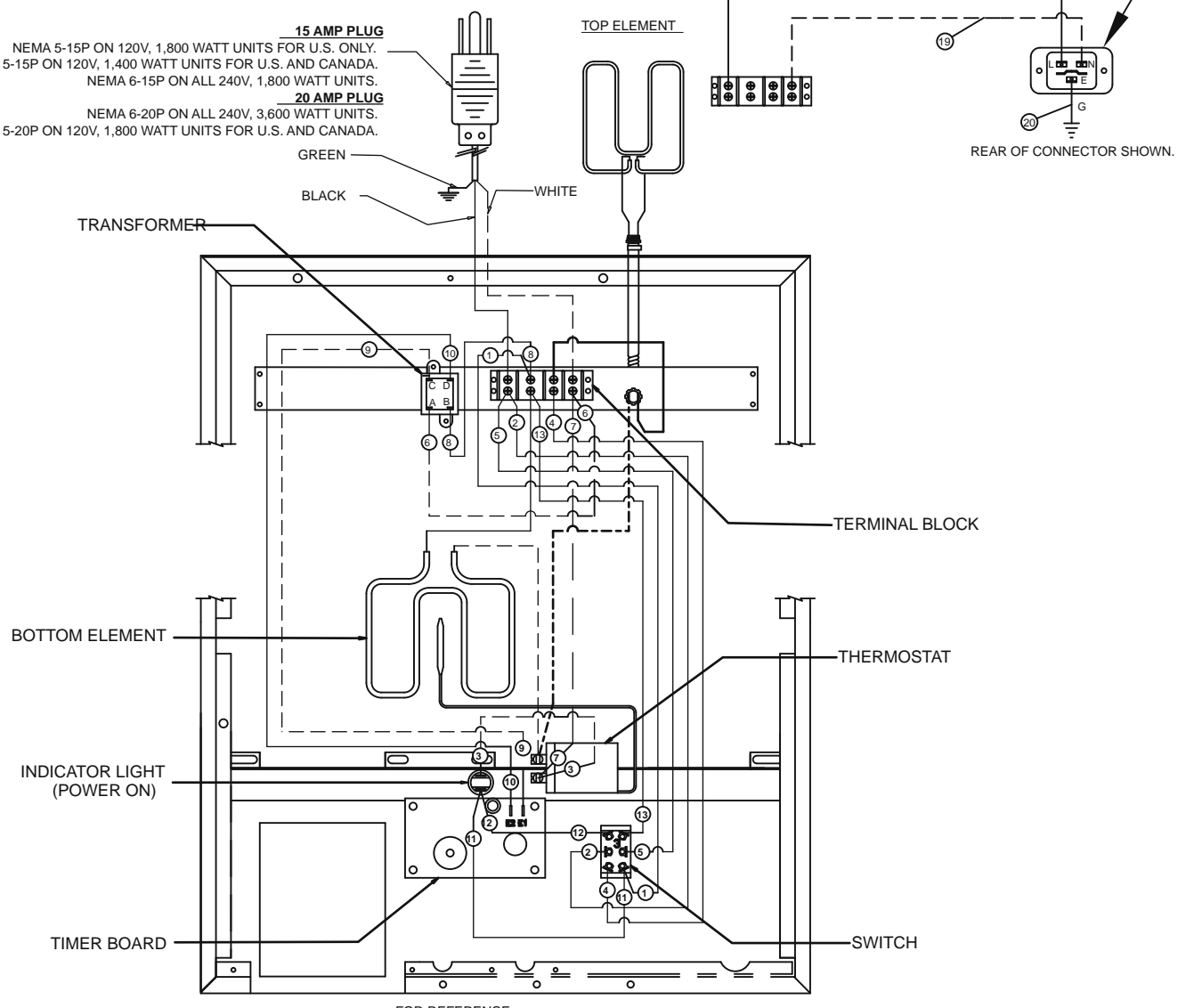

**WIRE DIAGRAM, CG/GR, 10/14, 120V/230/240V, WITH TIMER**



SOME ITEMS ARE INCLUDED FOR ILLUSTRATIVE PURPOSES ONLY AND IN CERTAIN INSTANCES MAY NOT BE AVAILABLE

**MODEL: SEE ABOVE**

**STAR MANUFACTURING INTERNATIONAL, INC.**

SK2001      REV. C      12/12/2005

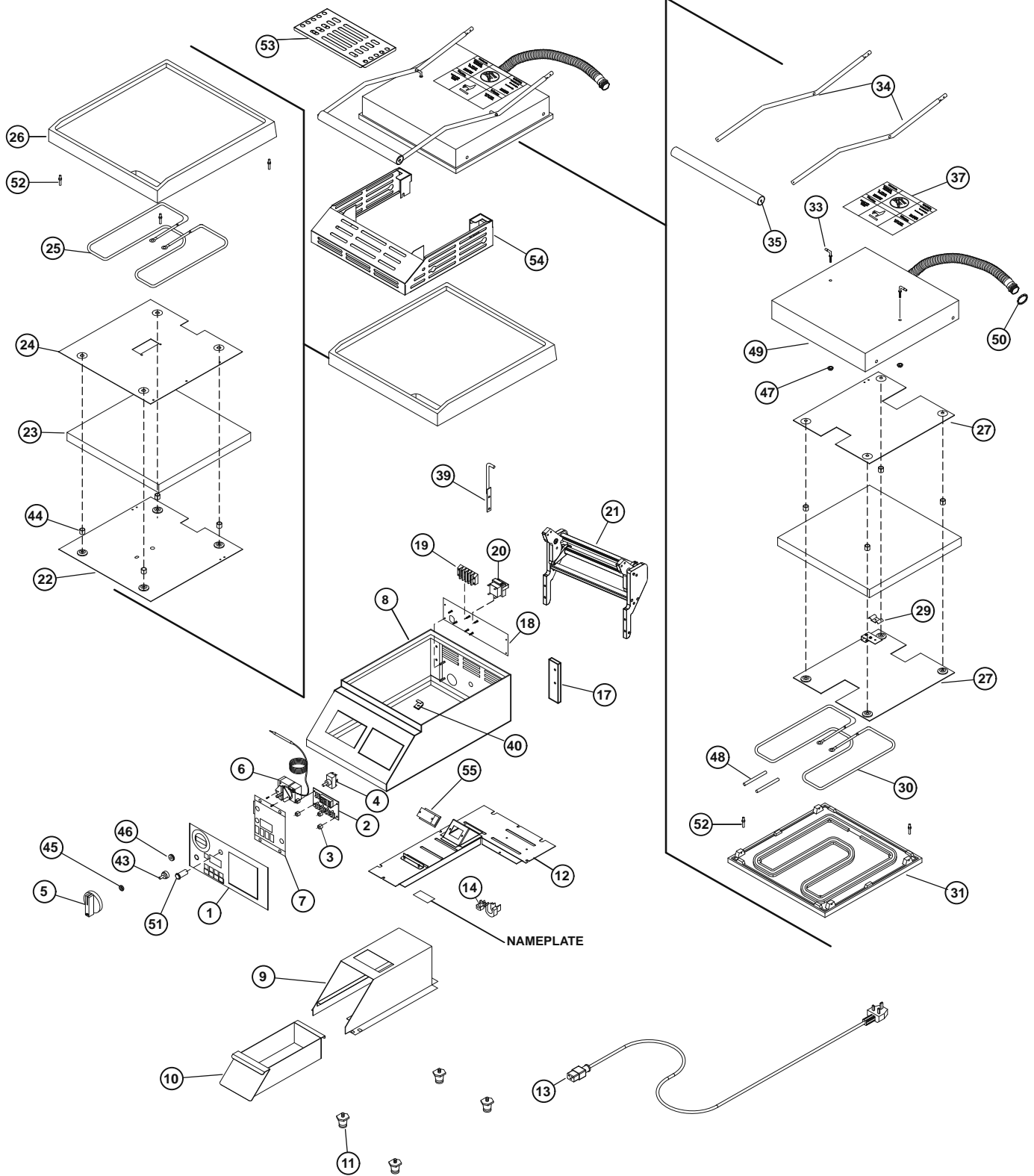

This drawing contains information confidential to Star Manufacturing International, Inc. No reproduction or disclosure of its contents is permitted.

SOME ITEMS ARE INCLUDED FOR ILLUSTRATIVE PURPOSES ONLY AND IN CERTAIN INSTANCES MAY NOT BE AVAILABLE

**MODEL: GR10T4K**



**STAR MANUFACTURING INTERNATIONAL, INC.**

SK2164

REV. -

1/10/2006

# PARTS LIST

January 31, 2011 Rev. A

Star Two-Sided Grill  
MODEL GR10T4K-UK

Key Number	Part Number	Number Per Unit	Description
1	2M-Z9363	1	OVERLAY W/TIMER - 10"
2	2J-Z7668	1	TIMER CONTROL
3	2K-Z1971	4	SPACER
4	2E-Z6863	1	SWITCH - 3 POSITION
5	2R-Z4621	1	KNOB - CONTROL
6	2T-6447	1	THERMOSTAT 118V-236V
7	D9-GR0234	1	FACEPLATE ASSEMBLY - 10" WITH TIMER
8	D9-GR0328	1	BODY ASSEMBLY - 10"
9	D9-GR0034	1	GREASE CABINET ASSEMBLY
10	D9-GR0215	1	GREASE DRAWER ASSEMBLY
11	2A-Z7760	4	FOOT - 1" ADJUSTABLE
12	D9-GR0302	1	BASE BOTTOM - 10"
13	2E-Z9192	1	CORD POWER
14	2K-Y3240	1	BUSHING HEYCO SR 17-2
17	2A-Z6484	2	PLATE - COUNTER BALANCE MOUNT
18	D9-GR0053	1	REAR LINER ASSEMBLY - 10" BOTTOM
19	2E-Z2894	1	TERMINAL BLOCK
20	2E-05-07-0350	1	TRANSFORMER 230V//10V 6VA
21	2R-Z2907	1	COUNTER BALANCE - 10" IRON
22	D9-Z2774	1	BOTTOM INSULATION RETAINING PLATE - 10"
23	D9-Z2908	1	INSULATION - 10"
24	D9-Z2773	1	BOTTOM ELEMENT RETAINING PLATE - 10"
25	2N-Z2020	1	ELEMENT, HEATING 1000W/240V (BOTTOM) 230V
26	2F-Z1929	1	CASTING - SMOOTH BOTTOM - 10" ALUMINUM
27	D9-Z2772	1	TOP ELEMENT - INSULATED PLATE - 10"
28	D9-GR0084	1	TOP RETAINING PLATE ASSEMBLY - 10"
29	B9-04-WB-0046	1	CLAMP WIRE SUPPORT
30	PS-Z2019	1	ELEMENT - HEATING 800W/240V (TOP) 230V
31	2F-Z1928	1	CASTING - SMOOTH TOP - 10" ALUMINUM
33	2C-Z3200	2	PIN - TOP HOUSING
34	2B-Z2988	2	ARM - 10"
35	2V-Z2990	1	HANDLE - 10"
37	2M-Z2620	1	LABEL - CAUTION (BI-LINGUAL)
39	2V-Z3252	1	ROD - TOP HOUSING LATCH
40	2A-Z3026	1	HALF CLIP .437
43	2I-05-07-0013	1	BOOT - SWITCH
44	2A-Z6604	8	SPACER - INSULATION PLATE
45	2I-Z3380	2	THERMOSTAT SEAL WASHER
46	2I-Z3379	1	GROMMET - THERMOSTAT
47	2C-Z2899	2	5/16-18 UNC LOCKNUT
48	1O-E1500	0.33	SLEEVING #4 .208ID GLASS
49	D9-GR0203	1	TOP HOUSING AND CONDUIT ASSEMBLY
50	2E-Z3768	1	LOCKNUT, CONDUIT, 1/2 INCH
51	2J-Z2329	1	PILOT LIGHT 230V
52	2C-08-07-0285	8	STUD, SELF TAPPING
53	D9-GR0326	1	TOP BURN GUARD ASSY. 10"
54	D9-GR0327	1	BURN GUARD ASSY. FRONT & SIDE - 10"
55	2E-Y9253	1	INLET IEC320 16 AMP

**IMPORTANT: WHEN ORDERING, SPECIFY VOLTAGE OR TYPE GAS DESIRED  
INCLUDE MODEL AND SERIAL NUMBER**

PAGE 1  
OF 1

Some items are included for illustrative purposes only and in certain instances may not be available.



**Star Manufacturing International, Inc.**

STAR INTERNATIONAL HOLDINGS INC. COMPANY  
Star - Holman - Lang - Wells - Bloomfield - Toastmaster  
10 Sunnen Drive, St. Louis, MO 63143 U.S.A.  
(314) 781-2777  
[www.star-mfg.com](http://www.star-mfg.com)