

GR28IEPE; 28" Split-Top 28" Sandwich Grill, Panda Express

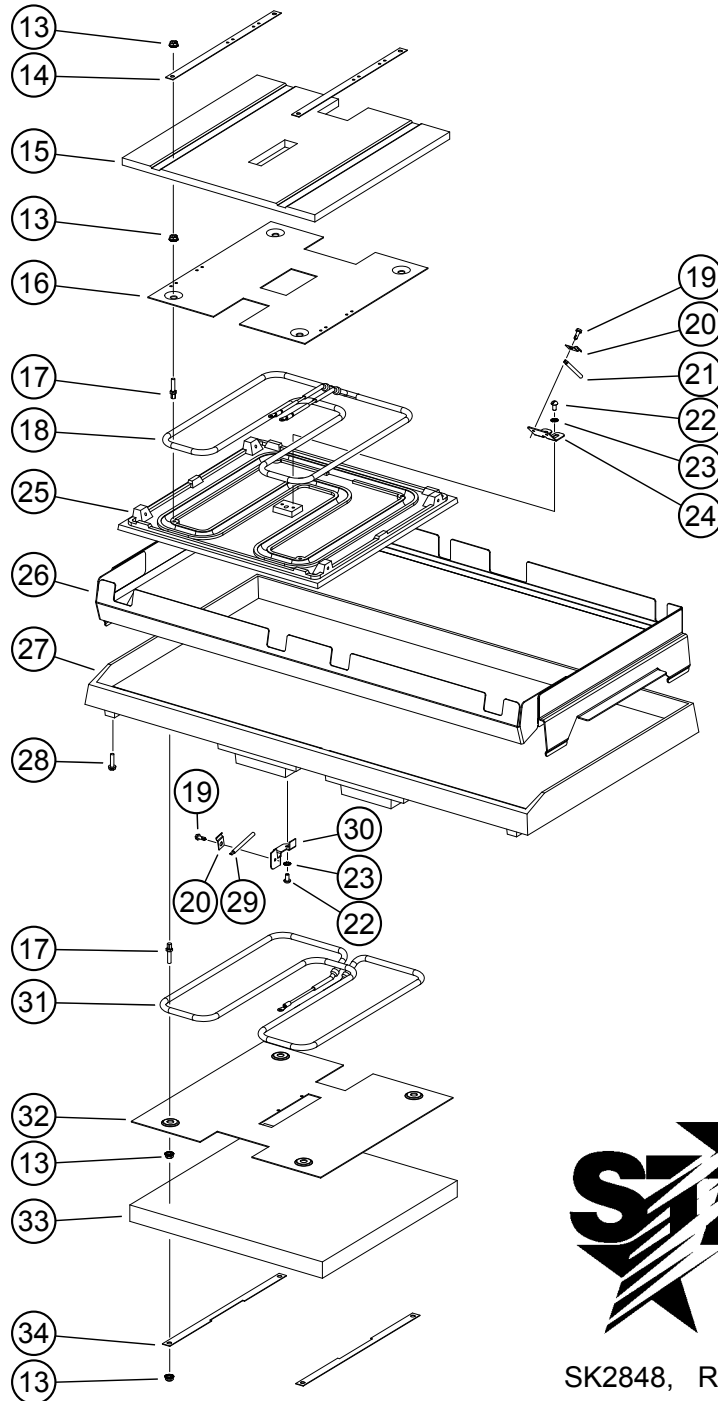

Model: GR28IEPE
Platen Assembly

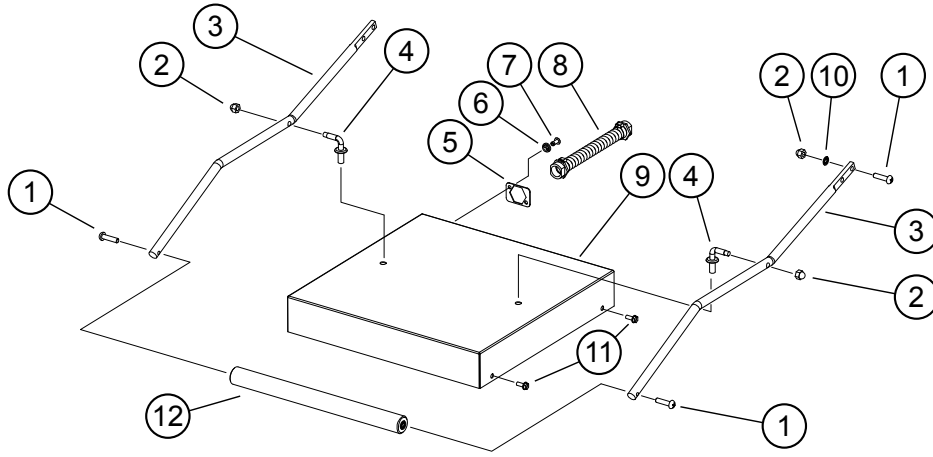

SK2848, Rev. - 2/02/15

PARTS LIST

April 14, 2015

Model: GR28IEPE, Panda Express 28" SG Platen Assy			
Fig	Part Number	Quantity	Description
1	2C-Z2992	6	BOLT 1/4-20X1 PHP STL NP
2	2C-40637	12	NUT 1/4-20 ACORN CAP MS S
3	2B-Z2987	4	ARM - 14"
4	2C-Z3200	4	PIN - TOP HOUSING
5	2A-Z3827	2	PLATE,STAMPING - CONDUIT
6	2C-Z3780	4	RETAINER, CONDUIT
7	2C-Z3917	4	RIVET, POP, .188 (AD66BS)
8	2E-Z2898	2	CONDUIT ASSY. - PTFE
9	D9-Z4849	2	HOUSING - TOP - 14"
10	2C-08-07-0262	4	WASHER, SS 1/4 INT - LOCK
11	2C-Z5883	10	10-24 X 1/2 FZA SCREW
12	2V-Z2989	2	HANDLE- 14"
13	2C-Z2893	24	NUT 10-24 HEX STL ZP
14	D9-Z13099	4	BRACKET, INSLUATION
15	D9-Z2888	2	INSULATION - 14"
16	D9-Z2075	2	TOP ELEMENT/INS. PLATE/14
17	2C-08-07-0285	16	SCREW 10-24X3/4X3/8 TYPE
18	D9-GR0712	2	ELMNT(MAKE FRM 2N-Z19370)
19	2C-8833	4	SCREW 8-18X1/2 HEX STL NP
20	2C-Z3350	4	HALF CLAMP .188 D STL ZP
21	2E-Z3278	2	RTD PROBE - 60" LONG WIRE
22	2C-1512	4	SCREW 10-24X3/8 RHP STL
23	2C-1827	6	WASHER #10 EXT STL NP
24	D9-Z14856	2	BRACKET, PROBE MOUNT
25	2F-Z1948	2	CASTING,SM.TOP,IRON-14
26	D9-GR0713	1	SPLASH GUARD ASSY
27	2F-Z1962	1	CASTING SM. BOT IRON-28
28	2C-08-07-0117	8	SCREW 10-24X3/4 FZA
29	2E-Z1470	2	SNSR-RTD,2K OHM,24"LDS
30	D9-Z12027	2	PROBE BRACKET - BOTTOM
31	2N-Z19370	2	ELEMENT,2700W,208V,BTM
32	D9-Z13338	2	ELEM & INSUL PLT BTM 14"
33	D9-Z2888	2	INSULATION - 14"
34	D9-Z12885	4	INSULATION HOLD DOWN,

GR28IEPE: 28" Split-Top 28" Sandwich Grill, Panda Express

GR28IEPE; 28" Split-Top 28" Sandwich Grill, Panda Express

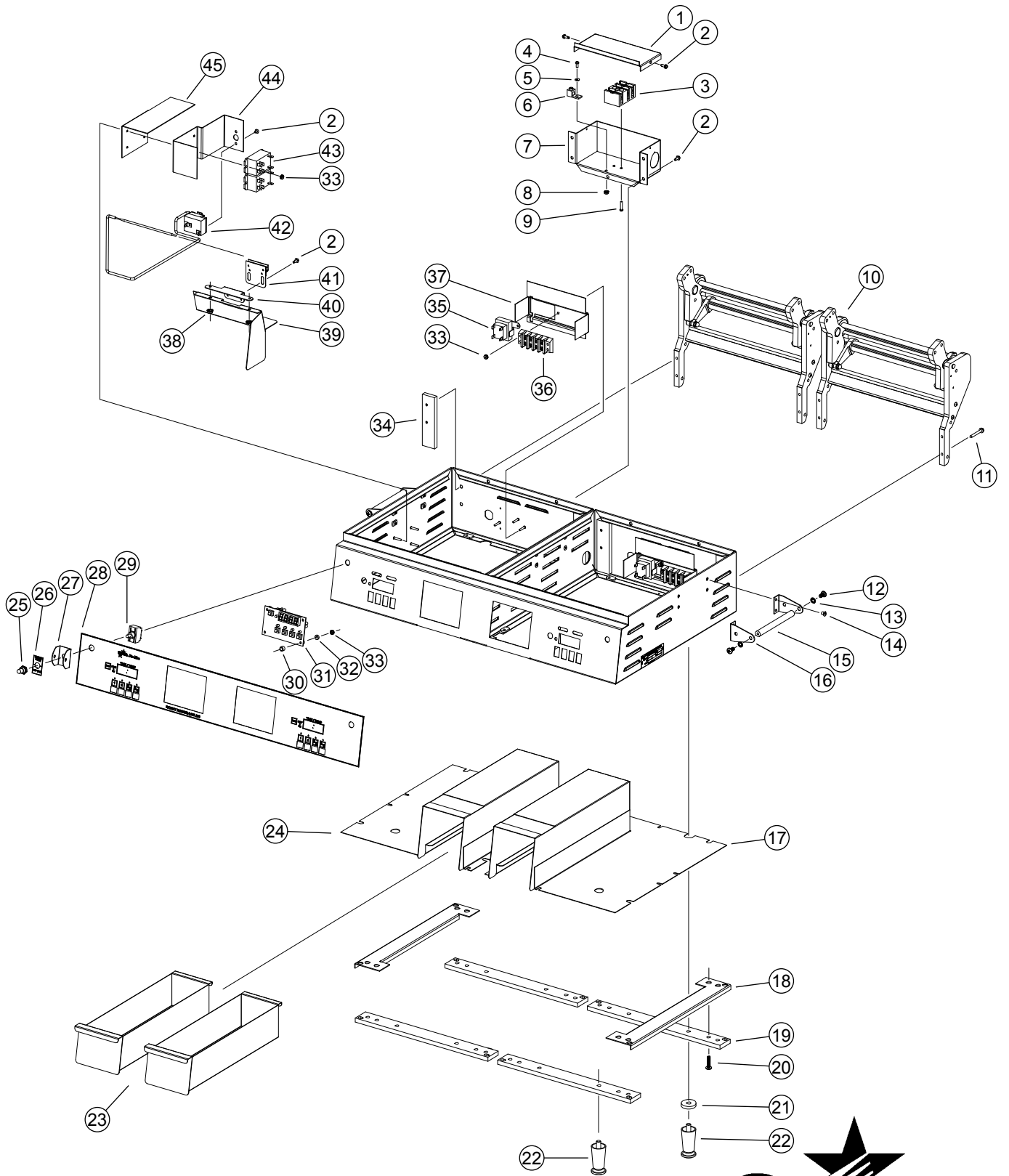

Model: GR28IEPE
Base Assembly



SK2849, Rev. A 4/14/15

PARTS LIST

April 14, 2015

Model: GR28IEPE, Panda Express 28" SG Base Assy			
Fig. No	Part Number	Quantity	Description
1	G5-Z8481	1	JUNCTION BOX COVER
2	2C-8833	11	SCREW 8-18X1/2 HEX STL NP
3	2E-Z8482	1	TERMINAL BLOCK
4	2C-1493	1	SCREW 8-32X3/8 RHP STL NP
5	2C-200110	1	WASHER, #8 FLAT 18-8 SS
6	2E-Z8423	1	TERMINAL LUG 14-2 AL-CU
7	D9-GR0730	1	JUNCTION BOX
8	2C-Z7165	3	NUT 8-32 HEX SS W/EXT WSH
9	2C-1496	2	SCREW 8-32X3/4 RHP STL NP
10	2R-Z19214	2	COUNTER BALANCE IRON, SS CAMS
11	2C-Z2593	8	SCRW 10-24x1.5 SL HX/W NP
12	2C-1512	4	SCREW 10-24X3/8 RHP STL
13	2C-08-07-0262	8	WASHER, SS 1/4 INT - LOCK
14	2C-Y4275	12	RIVET 3/16X.300 POP AL SM
15	2V-Z3072	2	HANDLE-SIDE
16	D9-Z3071	4	BRACKET - HANDLE
17	D9-GR0738	1	BASE ASSEMBLY, LEFT
18	D9-Z17202	2	SUPPORT, LEGS
19	2V-Z3027	4	CROSS SUPPORT
20	2C-Z2992	8	BOLT 1/4-20X1 PHP STL NP
21	2A-Z17372	2	LEG SPACER
22	2R-200716	4	LEG, 2.5" METAL
23	D9-GR0615	2	GREASE DRAWER ASSY
24	D9-GR0613	1	BASE ASSEMBLY
25	2I-05-07-0013	2	BOOT SWITCH
26	2M-Z18461	2	LABEL, POWER, ON AND OFF
27	Z1-70-07-0343	2	SWITCH GUARD
28	2M-Z18618	1	OVERLAY, 28" PANDA
29	2E-Z3808	2	SWITCH(EATON)-30A@120V,
30	2K-Z1971	8	SPACER .257X.75X.25 NYLON
31	D9-GR0716	1	CNTL PROGRAM, PANDA
32	2K-08-07-0004	8	SPACER ROUND NYLON
33	2C-Z2594	24	NUT 6-32 HEX W STL NP
34	2A-Z6484	4	PLATE (COUNTER BAL. MT.)
35	2E-05-07-0350	2	TRANSFORMER 230V/10V 6VA
36	2E-Z2894	2	TERMINAL BLOCK (304)
37	D9-Z20266	2	INTERNAL BAFFLE
38	2C-Z2893	4	NUT 10-24 HEX STL ZP
39	D9-Z20268	1	INTERNAL BAFFLE,CNTROL R/H
	D9-Z20269		INTERNAL BAFFLE,CNTROL L/H
40	D9-Z17491	2	BRACKET, MOUNTING
41	D9-GR0632	2	ASSEMBLY, PROBE CLAMP
42	2T-Z17489	2	THERMOSTAT,LIMITING,460F
43	2E-Z3335	4	RELAY DBL POLE-SNGL THROW
44	D9-GR0272	2	BRACKET, HIGH LIMIT
45	D9-Z20267	1	INTERNAL BAFFLE, RELAY L/H
	D9-Z20270		INTERNAL BAFFLE, RELAY R/H
NI	2E-Z16462	1	CORD SET, 6/3 6-50P K&H

GR28IEPE; 28" Split-Top 28" Sandwich Grill, Panda Express