



**Star
Manufacturing
International Inc.**

10 Sunnen Drive
St. Louis, MO 63143

Phone: (314) 678-6303
Fax: (314) 781-2714

**Installation
and
Operating
Instructions**

2M-Z4051 Rev. P 8/14/13

HOT FOOD HUMIDITY CABINET MODEL HFD-1CRPL



SAFETY SYMBOL



These symbols are intended to alert the user to the presence of important operating and maintenance instructions in the manual accompanying the appliance.

RETAIN THIS MANUAL FOR FUTURE REFERENCE NOTICE

Using any part other than genuine Star factory supplied parts relieves the manufacturer of all liability.

Star reserves the right to change specifications and product design without notice. Such revisions do not entitle the buyer to corresponding changes, improvements, additions or replacements for previously purchased equipment.

Due to periodic changes in designs, methods, procedures, policies and regulations, the specifications contained in this sheet are subject to change without notice. While Star International Holdings Inc., Company exercises good faith efforts to provide information that is accurate, we are not responsible for errors or omissions in information provided or conclusions reached as a result of using the specifications. By using the information provided, the user assumes all risks in connection with such use.

MAINTENANCE AND REPAIRS

Contact your local authorized service agent for service or required maintenance.

Please record the model number, serial number, voltage and purchase date in the area below and have it ready when you call to ensure a faster service.

Model No. _____

Serial No. _____

Voltage _____

Purchase Date _____

Authorized Service Agent Listing

Reference the listing provided with the unit

OR

for an updated listing go to:

Website: www.star-mfg.com
E-mail Service@star-mfg.com

Service Help Desk

Business Hours: 8:00 am to 4:30 p.m. Central Standard Time

Telephone: (314) 678-6303

Fax: (314) 781-2714

E-mail Parts@star-mfg.com
Service@star-mfg.com
Warranty@star-mfg.com

Website: www.star-mfg.com

Mailing Address: Star International Holdings Inc., Company
10 Sunnen Drive
St. Louis, MO 63143
U.S.A

SPECIFICATIONS

HFD-1CRPL120

Capacity: Four 12" (30cm) Pizza Shelves

Electrical: 120 volt, 50/60 hertz, single phase, 1200 watts, 10 amps

Dimensions: 15" W x 15" D x 28-1/4" H
(38.1 cm W x 38.1 cm D x 71.7 cm H)

Weight: Approximately 62 lbs. (28 kg)

OPERATING CONTROLS

The temperature controls are located at the top of the unit above the door and the humidity controls are located on the bottom of the unit below the door (see Figures 1 and 2).

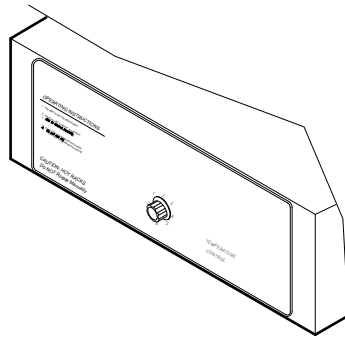

Figure 1

Temperature Dial - Adjusts cabinet temperature

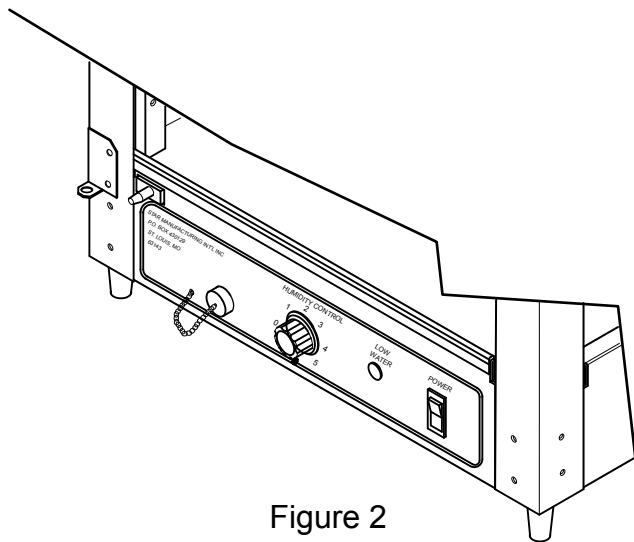

Figure 2

- ON/OFF Switch** - Activates cabinet light, and air circulation system.
- Humidity Dial** - Adjusts cabinet humidity.
- Low Water Indicator** - Illuminates when water needs to be added.
- Drain Tube** - Allows the water reservoir to be emptied during cleaning.
- Door Switch** - Allows the rotisserie motor to rotate when the door is closed.



This equipment is designed and sold for commercial use only by personnel trained and experienced in its operation and is not sold for consumer use in and around the home nor for use directly by the general public in food service locations.

All shipping containers should be checked for freight damage both visible and concealed. This unit has been tested and carefully packaged to insure delivery of your unit in perfect condition. If equipment is received in damaged condition, either apparent or concealed, a claim must be made with the delivering carrier.

Concealed damage or loss - if damage or loss is not apparent until after equipment is unpacked, a request for inspection of concealed damage must be made with carrier within 15 days. Be certain to retain all contents plus external and internal packaging materials for inspection. The carrier will make an inspection and will supply necessary claim forms..

INSTALLATION

Each machine has been properly wired and inspected at the factory for operation on the voltage and type of current specified on the nameplate. Machines with a nameplate stamped 120V, are equipped for operation on 120 volt 50/60 hertz AC single phase service. Machines with a nameplate stamped 240V, are equipped for operation on 240 volt 50/60 hertz AC single phase service. Each condition must be connected to a separate 15 amp circuit with a 3 wire grounded, polarized receptacle.



DO NOT CONNECT TO ANY OTHER TYPE OF CURRENT OR THE MACHINE WILL BE SERIOUSLY DAMAGED.

The guarantee of this machine as covered by the warranty card does not apply if an improper installation has been made.

GENERAL OPERATING INSTRUCTIONS



DO NOT BLOCK VENT HOLES ON TOP OF THE CABINET

1. Ensure cabinet is plugged into the proper voltage receptacle prior to turning on.
2. Fill reservoir with water (distilled preferred) such that the water is approximately level with the top of the water reservoir (low water indicator should extinguish).
Capacity is 3/4 gallon (2.8 L).



DO NOT OVERFILL !

3. Follow preheat instructions on the following page. Allow approximately 15 minutes for the machine to reach the proper temperature.
4. Monitor product temperature via the thermometer (see Figure 3).
5. Load product into the racking system. For maximum product freshness, adjust the settings as specified. Pizza and pretzel racks are adjustable for different applications using the screws provided.
6. Periodically monitor the water level by the red indicator light on the lower control panel. If the light is illuminated, add water (distilled preferred) until the indicator light is no longer illuminated or to the maximum recommended water level (see Figure 4).



DO NOT OVERFILL !

7. See attached sketch for instructions on reversing the door.



Figure 3

CLEANING INSTRUCTIONS

1. Disconnect the electrical cord before cleaning the cabinet.
2. To maintain the finish and shine of the unit, wipe it daily with a damp cloth and mild soap. Do not use harsh detergents or scouring pads.
3. Daily cleaning of the inside glass, bottom pan and racking system with a damp cloth is recommended.
4. Unscrew the drain cap to drain the water reservoir. After the water reservoir is empty, recap the drain tube and fill to the recommended water level (see Figure 4).



DO NOT OVERFILL!

Recommended Dial Settings		
	Temp	Humidity
Preheat	6	2
Pizza	5.5	4

Temp Dial Settings	
Dial	Temp*
1	100°F / (43°C)
2	120°F / (49°C)
3	130°F / (55°C)
4	150°F / (66°C)
5	165°F / (74°C)
High	175°F / 80°C)

Humidity Dial Settings	
1, 2	Low
3, 4	Medium
5, 6	High

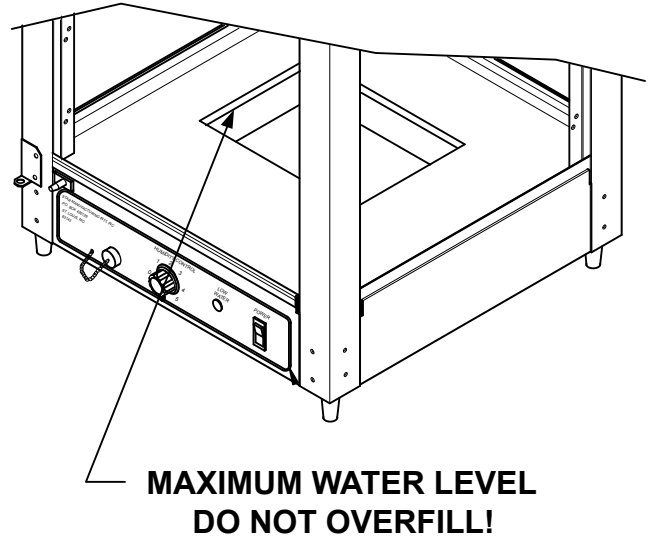

Figure 4

All settings are recommendations only and could vary depending on product preparation, cooking time, and internal food temperature.

FLUORESCENT LIGHT REPLACEMENT

1. Unplug the cord from the receptacle.
2. Remove the diffuser using a plastic screwdriver.
3. Replace the light with a new lamp 120V, model F8T5.
4. Install the diffuser back into the light holder.

Note: In the event of a loss of power, turn the main switch off, wait 5-10 minutes, then turn the main switch on. This procedure will prevent the fluorescent light from flickering.

THOROUGHLY INSPECT YOUR UNIT ON ARRIVAL

This unit has been tested for proper operation before leaving our plant to insure delivery of your unit in perfect condition. However, there are instances in which the unit may be damaged in transit. In the event you discover any type of damage to your product upon receipt, you must immediately contact the transportation company who delivered the item to you and initiate your claim with same. If this procedure is not followed, it may affect the warranty status of the unit.

LIMITED EQUIPMENT WARRANTY

All workmanship and material in Star products have a one (1) year limited warranty on parts & labor in the United States and Canada. Such warranty is limited to the original purchaser only and shall be effective from the date the equipment is placed in service. Star's obligation under this warranty is limited to the repair of defects without charge, by the factory authorized service agency or one of its sub-agencies. Models that are considered portable (*see below*) should be taken to the closest Star service agency, transportation prepaid.

- > Star will not assume any responsibility for loss of revenue.
- > On all shipments outside the United States and Canada, see International Warranty.
- * The warranty period for the Ultra-Max, Hot Plates, Griddles, Charbroilers is (3) years parts & labor.
- * The warranty period for the Star-Max, Charbroilers, Griddles, Hot Plates, Fryers & Finishing Oven is (2) years parts & labor.
- * The warranty period for the JetStar six (6) ounce & Super JetStar eight (8) ounce series popcorn machines is two (2) years.
- * The warranty period for the Chrome-Max Griddles is five (5) years on the griddle surface. See detailed warranty provided with unit.
- * The warranty period for Dura-Tec coatings is one year under normal use and reasonable care. This warranty does not apply if damage occurs to Dura-Tec coatings from improper cleaning, maintenance, use of metallic utensils, or abrasive cleaners, abrasive pads, product identifiers and point-of-sale attachments, or any other non-food object that comes in continuous contact with the roller coating. This warranty does not apply to the "non-stick" properties of such materials.
- > This warranty does not apply to "Special Products" but to regular catalog items only. Star's warranty on "Special Products" is six (6) months on parts and ninety (90) days on labor.
- > This warranty does not apply to any item that is disassembled or tampered with for any purpose other than repair by a Star Authorized Service Center or the Service Center's sub-agency.
- > This warranty does not apply if damage occurs from improper installation, misuse, wrong voltage, wrong gas or operated contrary to the Installation and Operating instructions.
- > This warranty is not valid on Conveyor Ovens *unless* a "start-up/check-out" has been performed by a Factory Authorized Technician.

PARTS WARRANTY

Parts that are sold to repair out of warranty equipment are warranted for ninety (90) days. The part only is warranted, the labor to replace the part is **NOT** warranted.

SERVICES NOT COVERED BY WARRANTY

1. Travel time and mileage rendered beyond the 50 mile radius limit
2. Mileage and travel time on portable equipment (*see below*)
3. Labor to replace such items that can be replaced easily during a daily cleaning routine, ie; removable kettles on fryers, knobs, grease drawers on griddles, etc.
4. Installation of equipment
5. Damages due to improper installation
6. Damages from abuse or misuse
7. Operated contrary to the Operating and Installation Instructions
8. Cleaning of equipment
9. Seasoning of griddle plates
10. Voltage conversions
11. Gas conversions
12. Pilot light adjustment
13. Miscellaneous adjustments
14. Thermostat calibration and by-pass adjustment
15. Resetting of circuit breakers or safety controls or reset buttons
16. Replacement of bulbs
17. Replacement of fuses
18. Repair of damage created during transit, delivery, & installation OR created by acts of God

PORTABLE EQUIPMENT

Star will not honor service bills that include travel time and mileage charges for servicing any products considered "Portable" including items listed below. These products should be taken to the Service Agency for repair:

- * The Model 510FD, 510FF Fryer.
- * The Model 526TOA Toaster Oven.
- * The Model J4R, 4 oz. Popcorn Machine.
- * The Model 518CMA & 526CMA Cheese Melter.
- * The Model 12MC & 15MC & 18MCP Hot Food Merchandisers.
- * The Model 12NCPW & 15NCPW Nacho Chip/Popcorn Warmer.
- * All Hot Dog Equipment **except Roller Grills & Drawer Bun Warmers.**
- * All Nacho Cheese Warmers **except Model 11WLA Series Nacho Cheese Warmer.**
- * All Condiment Dispensers **except the Model HPD & SPD Series Dispenser.**
- * All Specialty Food Warmers **except Model 130R, 11RW Series, and 11WSA Series.**
- * All QCS/RCS Series Toasters **except Model QCS3 & RCS3 Series.**
- * All Fast Steamer Models **except Direct Connect Series.**

ALL:

- * Pop-Up Toasters
- * Butter Dispensers
- * Pretzel Merchandisers
(Model 16PD-A Only)
- * Pastry Display Cabinets
- * Nacho Chip Merchandisers
- * Accessories of any kind
- * Sneeze Guards
- * Pizza Ovens
(Model PO12 Only)
- * Heat Lamps
- * Pumps-Manual

The foregoing warranty is in lieu of any and all other warranties expressed or implied and constitutes the entire warranty.

FOR ASSISTANCE

Should you need any assistance regarding the Operation or Maintenance of any Star equipment; write, phone, fax or email our Service Department. In all correspondence mention the Model number and the Serial number of your unit, and the voltage or type of gas you are using.



STAR MANUFACTURING INTERNATIONAL INC.

SK1822 Rev - 11/14/2000

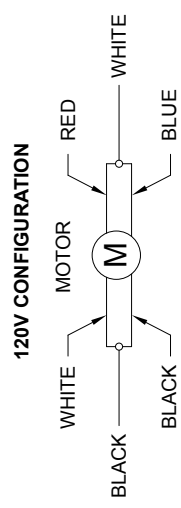
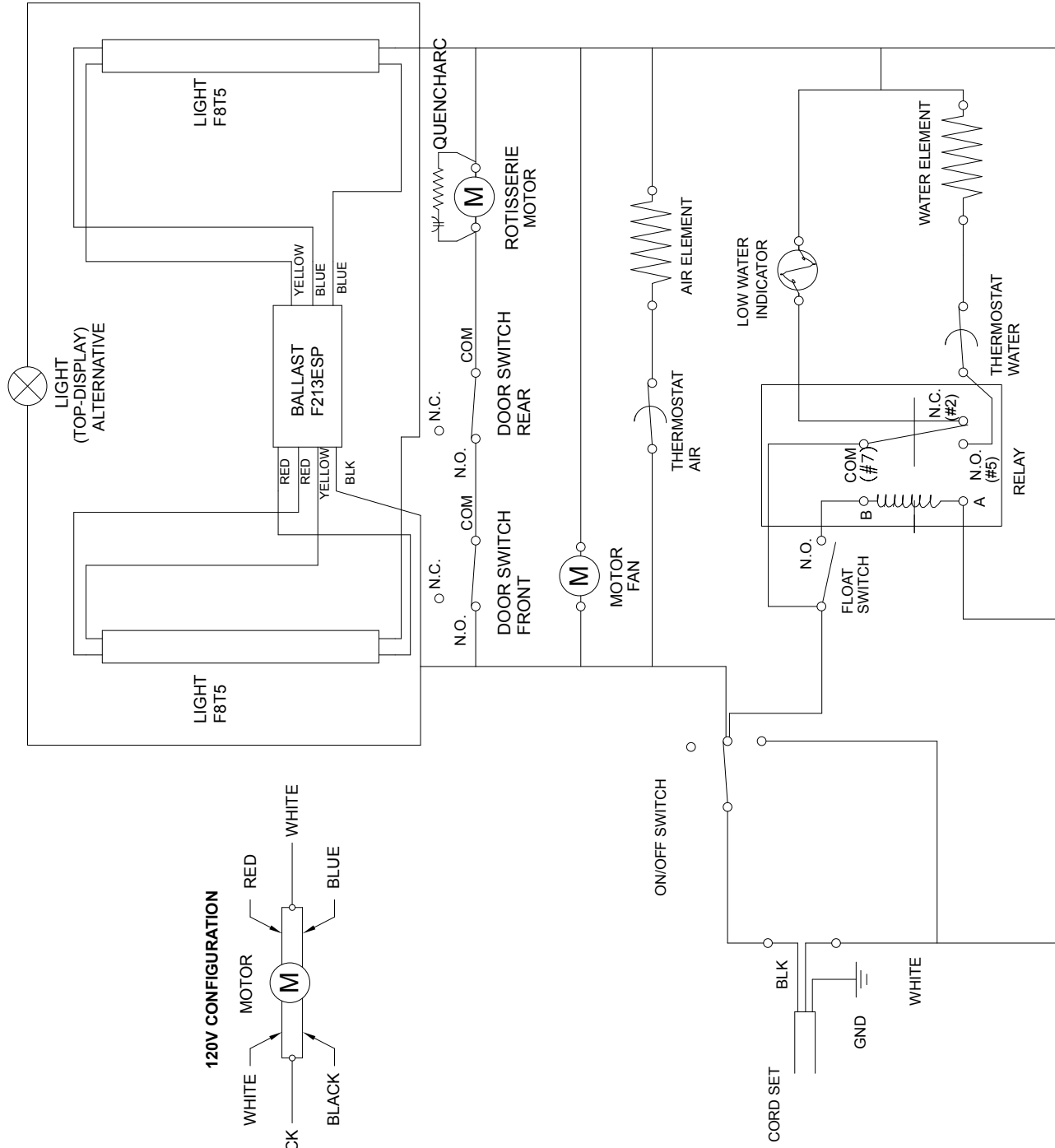

MODEL: HFD-1CRPL

THIS DRAWING CONTAINS INFORMATION CONFIDENTIAL TO STAR MFG. INTL. INC.
NO REPRODUCTION OR DISCLOSURE OF ITS CONTENTS IS PERMITTED.

INSTRUCTIONS FOR REVERSING THE DOOR ON UNIT

1. REMOVE THE TOP HINGE BRACKET ON THE LEFT POST AND INSTALL ON THE LOWER RIGHT POST.
2. REMOVE THE LOWER HINGE BRACKET ON THE LEFT POST.
3. ROTATE THE DOOR 360 DEGREES AND INSERT PIN ON THE BOTTOM OF THE DOOR INTO LOWER HINGE.
4. PLACE THE PREVIOUS LOWER BRACKET OVER THE PIN ON TOP OF THE DOOR AND RE-INSTALL THE HINGE BRACKET.

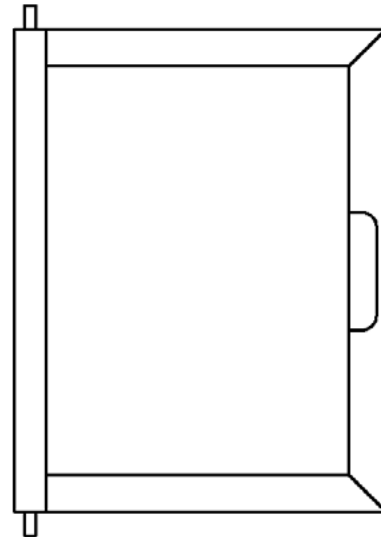
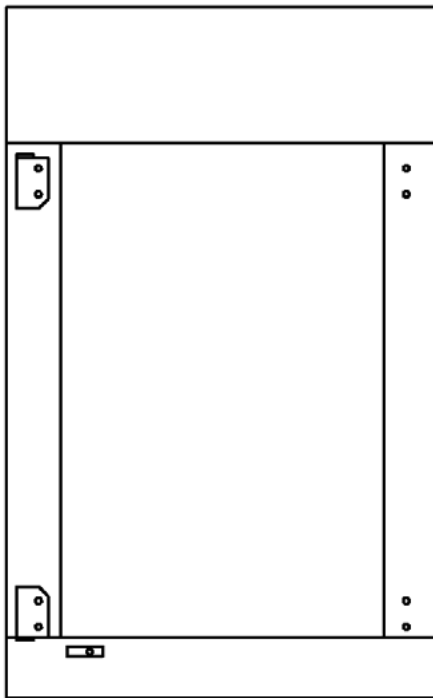

STANDARD DOOR CONFIGURATION

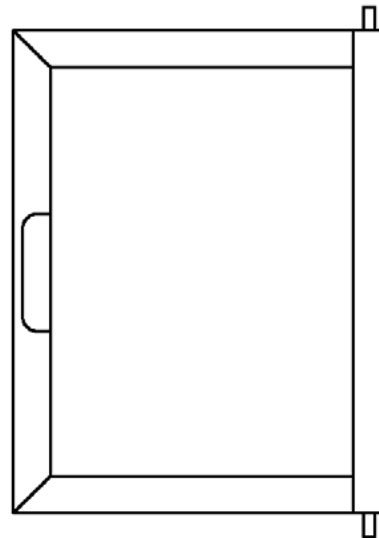
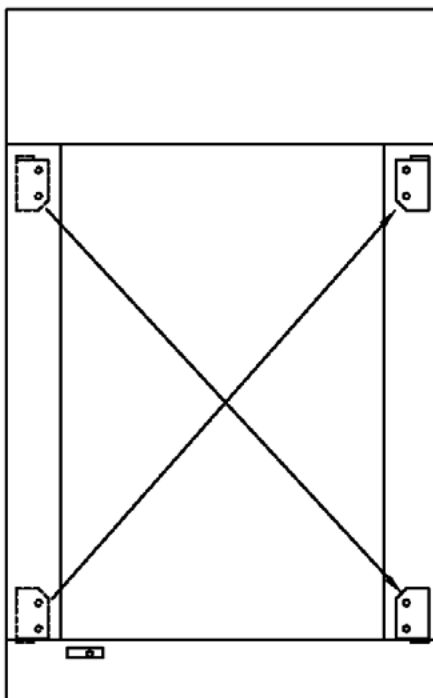

REVERSED DOOR CONFIGURATION

STAR MANUFACTURING INTERNATIONAL, INC.



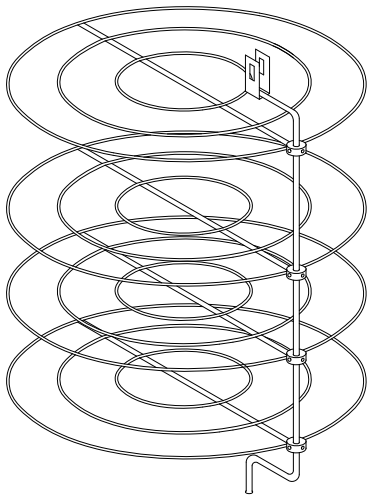

PIZZA RACK

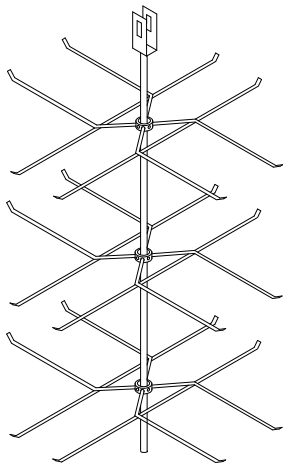

PRETZEL RACK
(OPTIONAL)

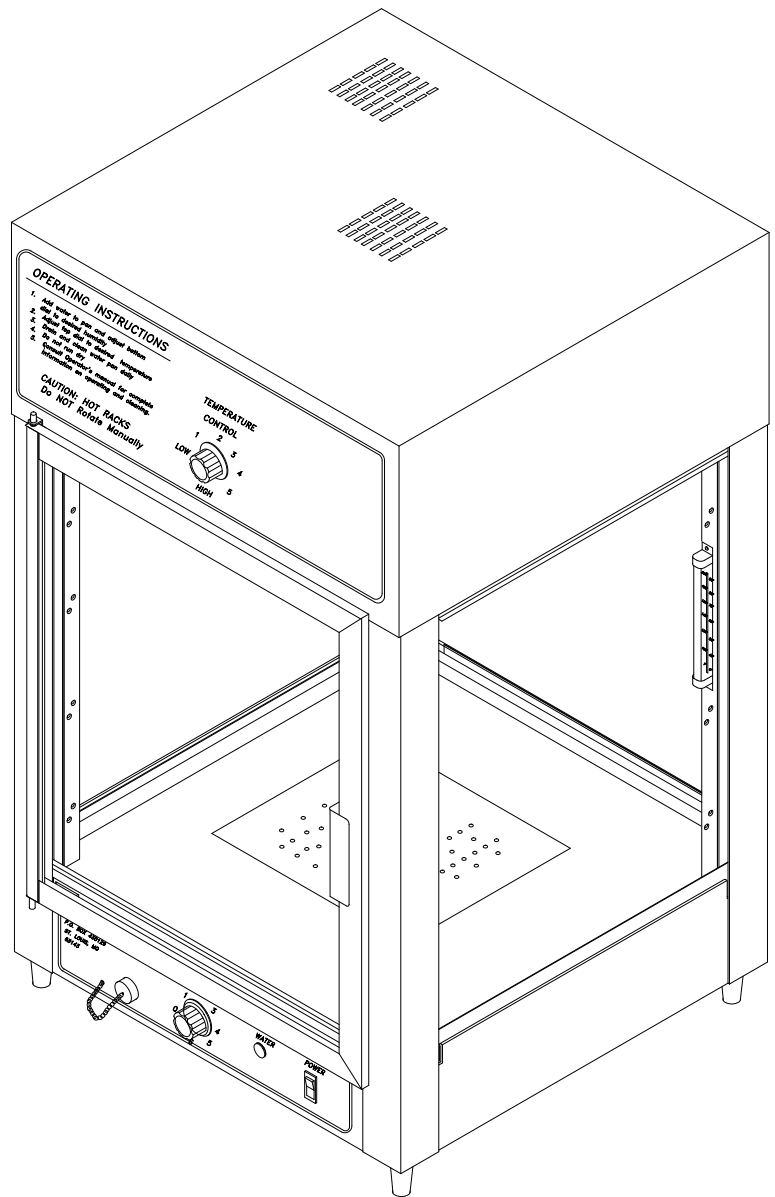

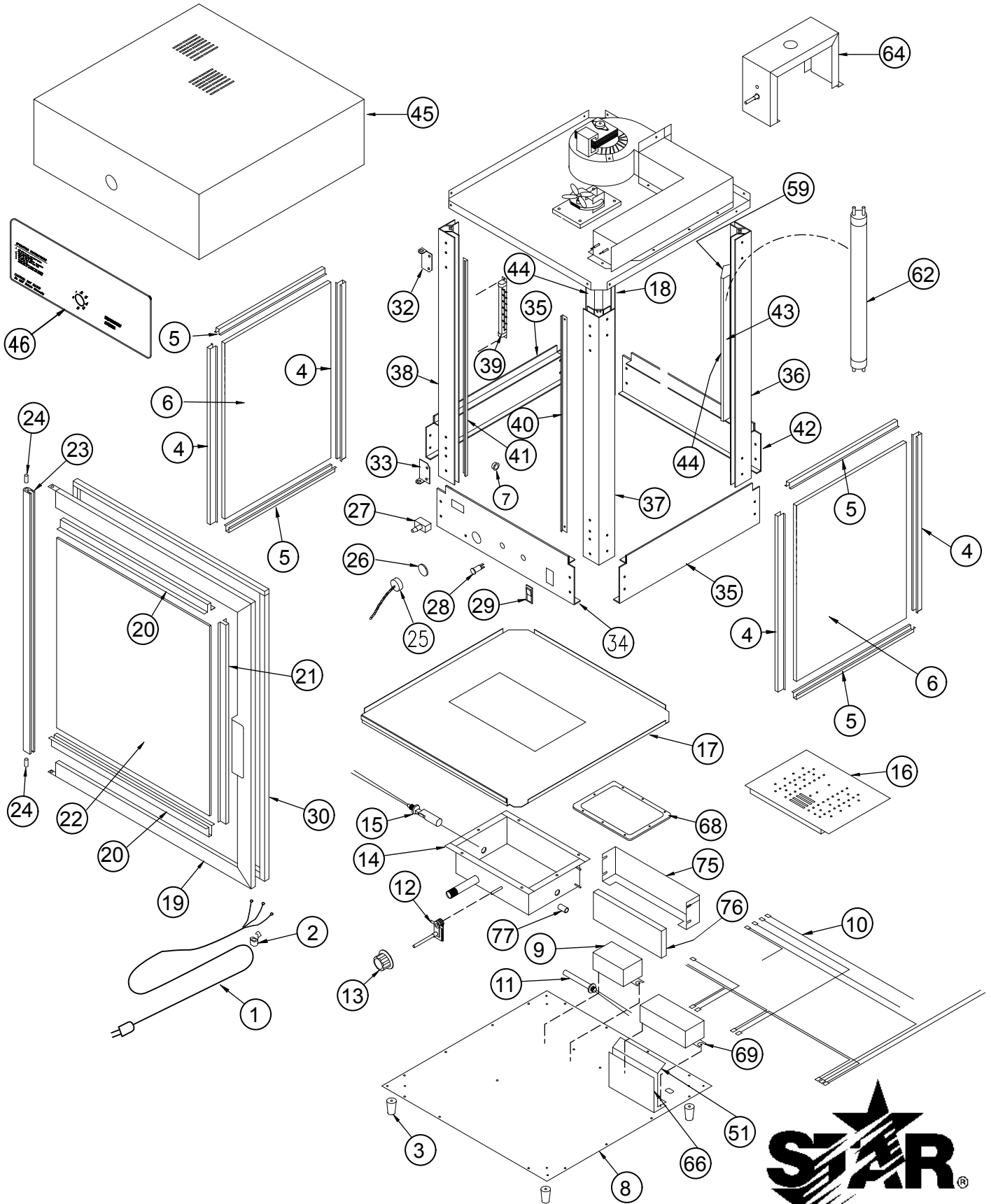

THIS DRAWING CONTAINS INFORMATION CONFIDENTIAL TO STAR MFG. INT'L. INC.
 NO REPRODUCTION OR DISCLOSURE OF ITS CONTENTS IS PERMITTED.

MODEL: HFD-1CRPL 120V

STAR MANUFACTURING INTERNATIONAL INC.

SK1825

Rev -

11/14/2000

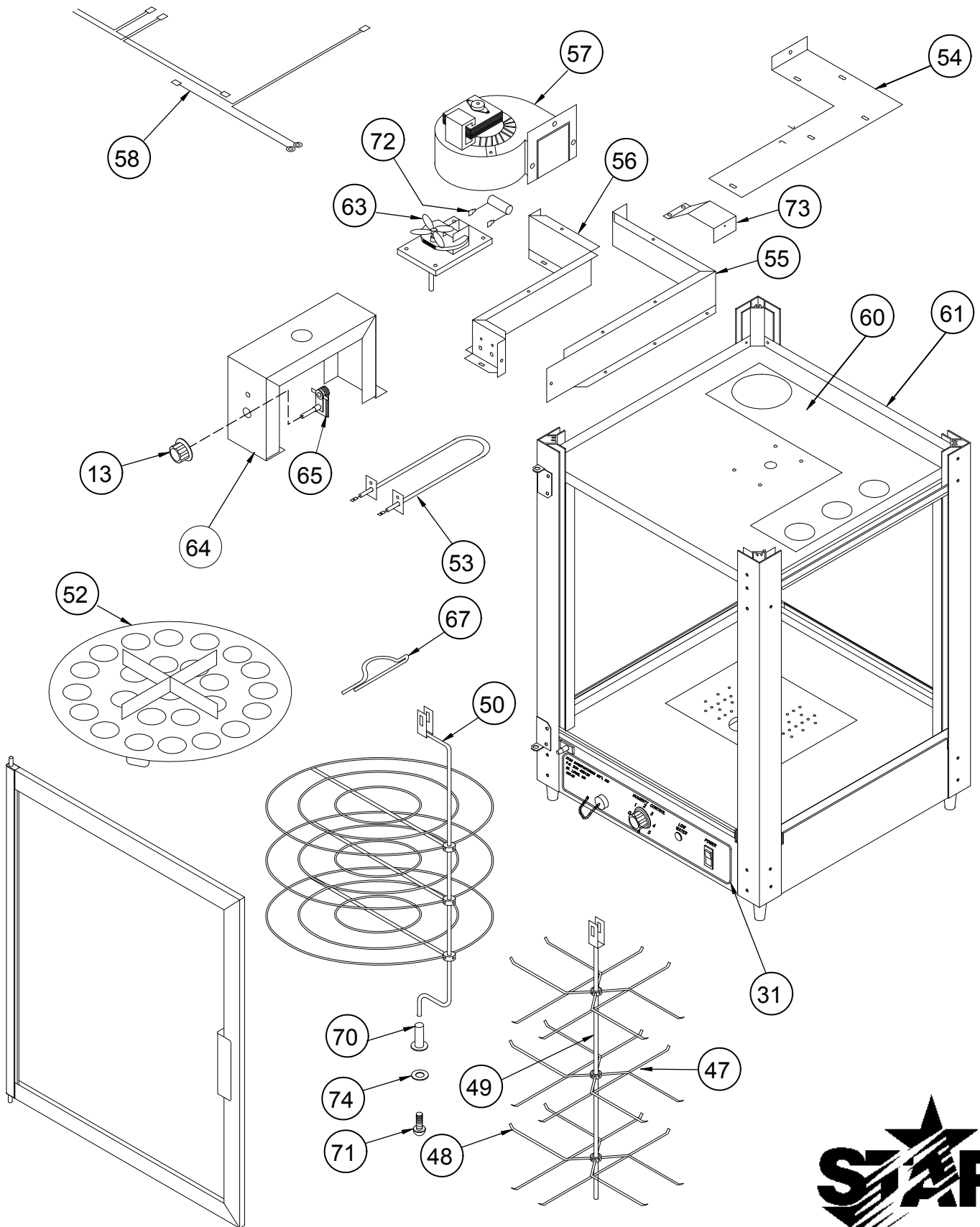

THIS DRAWING CONTAINS INFORMATION CONFIDENTIAL TO STAR MFG. INT'L. INC.
NO REPRODUCTION OR DISCLOSURE OF ITS CONTENTS IS PERMITTED.

MODEL: HFD-1CRPL 120V

STAR MANUFACTURING INTERNATIONAL INC.

SK1826

Rev -

11/14/2000



PARTS LIST

August 14, 2013, Rev F

MODELS HFD-1CRPL120 Humidity Cabinet

Key Number	Part Number	Number Per Unit	Description
1	C3-G8021	1	CORD ASSEMBLY 120V
2	2K-Y2968	1	BUSHING - STRAIN RELIEF
3	2A-Z1485	4	FOOT 1" ADJUSTABLE
4	D5-Z0345	4	GLASS CHANNEL VERTICAL
5	D5-Z0346	4	GLASS CHANNEL HORIZONTAL
6	2Q-Z0581	2	GLASS-SIDE
7	2K-1139	3	BUSHING-HEYCO
8	D5-Z3951	1	BOTTOM
9	2E-Y9148	1	RELAY 120V
10	2E-Z4053	1	WIRE HARNESS-BOTTOM
11	2N-Z3435	1	ELEMENT ASSEMBLY 120V
12	2T-Z4250	1	THERMOSTAT-WATER
13	2R-Y8261	2	KNOB
14	D5-220075	1	RESERVOIR ASSEMBLY
15	D5-220093	1	FLOAT SWITCH ASSEMBLY
16	D5-Z3954	1	TRAY
17	D5-220102	1	PAN ASSEMBLY
18	D5-Z3936	1	CORNER POST-RIGHT DOOR
19	D5-220103	2	DOOR FRAME ASSEMBLY
20	2I-Z0877	4	GLASS CHANNEL-HORIZONTAL DOOR
21	2I-Z0876	2	GLASS CHANNEL-VERTICAL DOOR
22	2Q-Z0759	2	GLASS-DOOR
23	2I-Z0758	2	HINGE-DOOR
24	2A-Y8068	4	PIN-DOWEL
25	A3-35219	1	CAP AND CHAIN
26	2I-9772	1	GASKET
27	2E-Y9700	2	SWITCH-INTERRUPT
28	2J-Y6689	1	PILOT LIGHT, 120V
29	PS-220117	1	SWITCH-SERVICE KIT (manufactured before 4/1/2010)
	2E-Z0091	1	SWITCH (manufactured after 4/1/2010)
30	2I-Z3934	2	DOOR-GASKET
31	2M-Z0880	1	LABEL-BOTTOM
32	D5-Z4171	2	HINGE-BRACKET (TOP)
33	D5-Z4172	2	HINGE-BRACKET (BOTTOM)
34	D5-Z0320	1	PANEL-CONTROL
35	D5-Z0319	2	ANGLE-BOTTOM
36	D5-Z3935	1	CORNER POST-LEFT DOOR
37	D5-Z3938	1	CORNER-POST-RIGHT
38	D5-Z3937	1	CORNER-POST-LEFT
39	2T-Z0613	1	THERMOMETER
40	D5-Z4006	2	FILLER RIGHT
41	D5-Z4005	2	FILLER LEFT
42	D5-Z3950	1	PANEL REAR
43	D5-Z3945	2	LIGHT HOLDER
44	2I-Z3939	2	DIFFUSER
45	D5-Z3952	1	TOP COVER
46	2M-Z0879	1	TOP LABEL
47	D5-220077	1	PRETZEL RACK ASSEMBLY (OPTIONAL)
48	2B-Z6899	3	HOLDER ASSEMBLY (OPTIONAL)
49	D5-220079	1	PRETZEL SHELF (OPTIONAL)
50	D5-220111	1	SHELF-PIZZA RACK ASSEMBLY
51	D5-Z4165	1	BRACKET-BALLAST
52	D5-220105	4	PIZZA-HOLDER ASSEMBLY

**IMPORTANT: WHEN ORDERING, SPECIFY VOLTAGE OR TYPE GAS DESIRED
INCLUDE MODEL AND SERIAL NUMBER**

PAGE 1
OF 2

Some items are included for illustrative purposes only and in certain instances may not be available.



Star Manufacturing International, Inc.

PARTS LIST

August 14, 2013, Rev F

MODELS HFD-1CRPL120 Humidity Cabinet

Key Number	Part Number	Number Per Unit	Description
53	2N-Z0337	1	ELEMENT-AIR 120V
54	D5-Z4311	1	COVER-DUCT
55	D5-Z4308	1	BACK-DUCT
56	D5-Z0591	1	FRONT-DUCT
57	2U-Z5583	1	BLOWER ASSEMBLY
58	2E-Z4052	1	HARNESSTOP
59	2S-Z3944	4	LAMP HOLDER
60	2I-Z3942	1	GASKET
61	D5-220101	1	TOP-LINER
62	2S-Z3943	2	FLUORESCENT LAMP F8T5, 12" LONG, 120V, 8W
63	D5-Z17319	1	MOTOR-ROTISSERIE 120V, Fan Not Included
NI	2U-Z9811	1	FAN, MOTOR
64	D5-Z4170	1	BRACKET-THERMOSTAT
65	2T-Z0449	1	THERMOSTAT-AIR
66	D5-Z4168	1	DEFLECTOR
67	2A-Y6694	1	HAIR PIN, 0.08X1 9/16
68	2I-Z1013	1	GASKET-PAN
69	2E-Z3948	1	BALLAST
70	2C-Z2829	1	NUT WELD (PIZZA-SHELF HOLDER)
71	2C-Z4251	1	SCREW #8-32X3/8, RHP ST.ST.
72	D5-220106	1	QUENCHARC ASSEMBLY
73	D5-Z4307	1	AIR-DEFLECTOR
74	2C-Z4320	1	WASHER #8 ST.ST.
75	D5-Z4322	1	INSULATION HOLDER
76	D5-Z4323	1	INSULATION
77	B9-04-WB-0140	4	SPACER

**IMPORTANT: WHEN ORDERING, SPECIFY VOLTAGE OR TYPE GAS DESIRED
INCLUDE MODEL AND SERIAL NUMBER**

PAGE 2
OF 2

Some items are included for illustrative purposes only and in certain instances may not be available.



Star Manufacturing International, Inc.

STAR INTERNATIONAL HOLDINGS INC. COMPANY

Star - Holman - Lang - Wells - Bloomfield - Toastmaster

10 Sunnen Drive, St. Louis, MO 63143 U.S.A.

(314) 678-6303

www.star-mfg.com