

This drawing contains information confidential to Star Manufacturing International, Inc. No reproduction or disclosure of its contents is permitted.

SOME ITEMS ARE INCLUDED FOR ILLUSTRATIVE PURPOSES ONLY AND IN CERTAIN INSTANCES MAY NOT BE AVAILABLE

MODEL: HFD-2A,-3A



STAR MANUFACTURING INTERNATIONAL, INC.

SK1714

Rev. B

6/08/2015

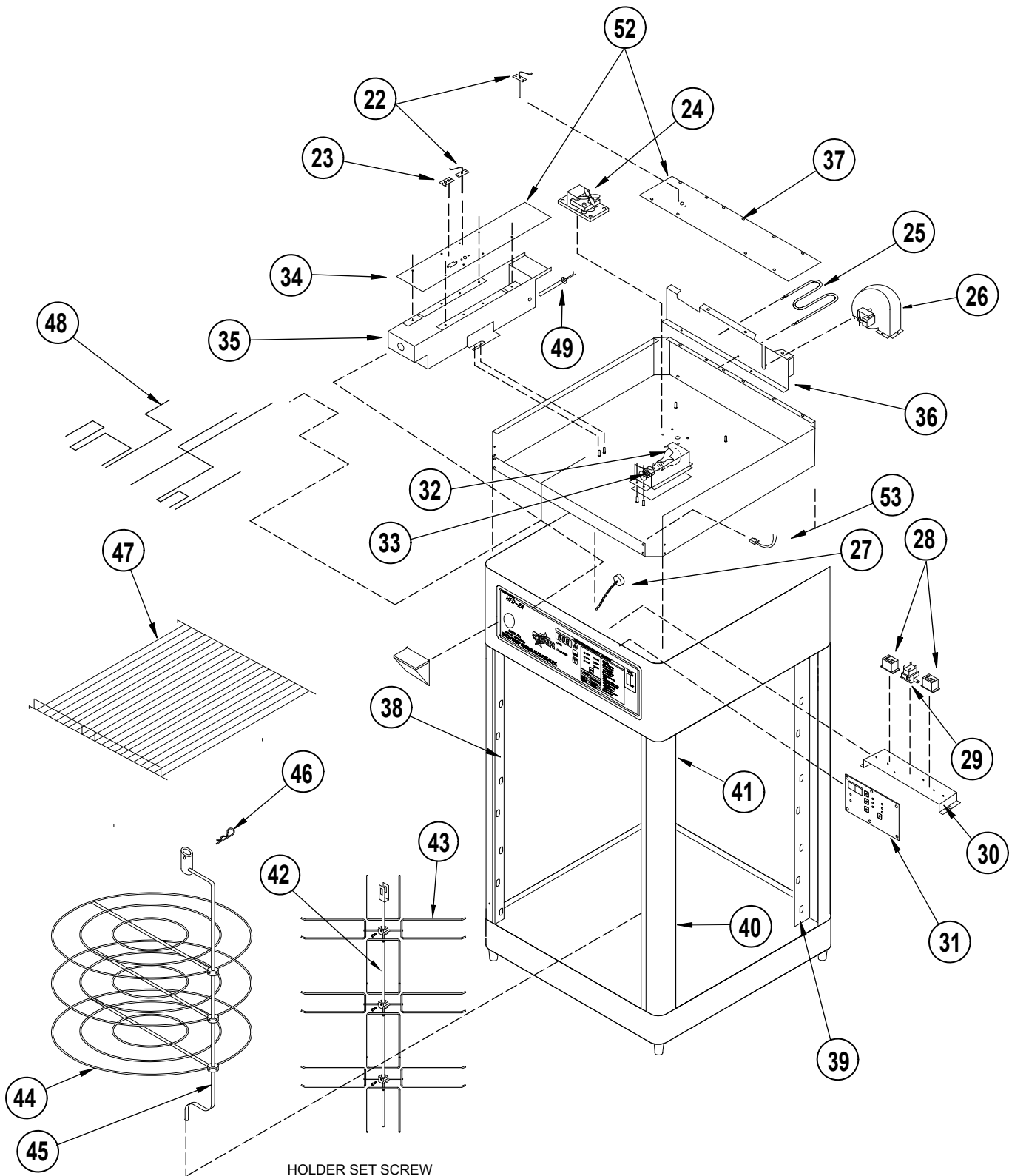

HOLDER SET SCREW
2C-Z5026 8-32 X 1/2 SS SHCS

This drawing contains information confidential to Star Manufacturing International, Inc. No reproduction or disclosure of its contents is permitted.

SOME ITEMS ARE INCLUDED FOR ILLUSTRATIVE PURPOSES ONLY AND IN CERTAIN INSTANCES MAY NOT BE AVAILABLE



STAR MANUFACTURING INTERNATIONAL, INC.

MODEL: HFD-2A,-3A 120V/230V

SK1375

REV. F

5-09-11

PARTS LIST

August 14, 2013, Rev. P

MODEL HFD2A and HFD3A HUMIDIFIED CABINET				
Fig No	Part No	Qty	Description	Application
1	C3-G8021	1	CORD ASSEMBLY	HFD-2A
	2E-05-07-0169			HFD-3A
	A4-120165			230V
2	2K-Y2967	1	BUSHING - HEYCO 7K-2 BLK	
3	2A-6904	4	FOOT	
4	D5-Y9623	4	GLASS CHANNEL	HFD-2A
	2I-Y7838			HFD-3A
5	2Q-Y9567	2	GLASS - SIDE	HFD-2A / -2APT
	2Q-Y9110			HFD-3A / -3APT
	2Q-Y9121	1	GLASS - BACK	HFD-3A
6	D5-Y9624	6	GLASS CHANNEL	HFD-2A
	2I-Y7840			HFD-3A
7	2K-Y1139	1	BUSHING - HEYCO	
8	2I-Y7839	2	GLASS CHANNEL-TOP AND BOTTOM	HFD-3A
9	D5-220038	1	BOTTOM ASSEMBLY	HFD-2A
	D5-220029			HFD-3A
10	D5-HFD004	1	WATER FILL ASSEMBLY	
11	2C-Z3389	1	NUT, WATER FILL ASSEMBLY	
12	D5-Z3401	1	TOP COVER	HFD-2A
	D5-Z3409			HFD-3A
13	2M-Z4180	1	LABEL-OPERATOR PANEL	HFD-2A
	2M-Z4181			HFD-3A
14	D5-HFD014		TOP DOOR BRACKET ASSEMBLY	
15	D5-HFD032	1	GLASS DOOR ASSEMBLY w/ MAGNET	HFD-2A / -2APT
	D5-HFD033			HFD-3A / -3APT
NI	2R-Z3494		MAGNET STRIP, DOOR	
16	D5-HFD017		BOTTOM DOOR BRACKET ASSEMBLY	
17	D5-Z3573	1	BOTTOM REAR - CUSTOMER	HFD-2A
	D5-Z3418			HFD-3A
18	D5-Z3417	1	BOTTOM WRAP - OPERATOR	HFD-2A
	D5-Z3574			HFD-3A
19	D5-HFD034		DOOR SWITCH BRACKET & MAGNET	
20	2E-Z12327	1	SWITCH, SPST NON-LIGHTED	
	PS-HFD041		HFD-2A ON/OFF LIGHTED SWITCH REPL. KIT	HFD-2A
	PS-HFD042		HFD-3A ON/OFF LIGHTED SWITCH REPL. KIT	HFD-3A
21	D5-Z3729	1	DOOR STOP FILLER	HFD-2A
	D5-Z3730			HFD-3A
22	2E-Z3236	2	THERMISTER SENSOR	
23	D5-HFD003	1	WATER LEVEL SENSOR ASSEMBLY	

IMPORTANT: WHEN ORDERING, SPECIFY VOLTAGE OR TYPE GAS DESIRED
INCLUDE MODEL AND SERIAL NUMBER

PAGE 1
OF 2



Star Manufacturing International, Inc.

PARTS LIST

August 14, 2013, Rev. P

MODEL HFD2A and HFD3A HUMIDIFIED CABINET				
24	D5-Z17319	1	ROTISSERIE MOTOR (120V), Fan Blade Not Included	
	2U-Z3642		ROTISSERIE MOTOR (230V), Fan Blade Not Included	
NI	2U-Z9811	1	FAN BLADE, MOTOR	
25	2N-Y9145	1	AIR HEATER (120V)	HFD-2A
	2N-Z0628		AIR HEATER (230V)	HFD-2A
	2N-Z3678		AIR HEATER (120V)	HFD-3A
	2N-Z4150		AIR HEATER (230V)	HFD-3A
26	2U-Z3412	1	BLOWER (120V/230V)	
27	A3-35219	1	CAP AND CHAIN	
28	2E-05-07-0352	2	RELAY	
29	2E-05-07-0351	1	TRANSFORMER	120V
	2E-05-07-0350			230V
30	D5-Z3543	1	CONTROL MOUNTING BRACKET	
31	2E-Z3287	1	CONTROL BOARD (120V/230V)	
32	2S-Z3608	1	BULB - STANDARD 75 WATT (120V)	120V
	2S-Z0630		BULB - STANDARD 100 WATT (230V)	230V
33	2E-Y9184	1	SOCKET	
34	D5-Z3396	1	COVER RESERVOIR	HFD-2A
	D5-Z3406			HFD-3A
35	D5-HFD007	1	RESERVOIR ASSEMBLY	HFD-2A
	D5-HFD008			HFD-3A
36	D5-Z3399	1	FRONT AIR DUCT	HFD-2A
	D5-Z3410			HFD-3A
37	D5-Z3400	1	COVER AIR DUCT	HFD-2A
	D5-Z3408			HFD-3A
38	D5-Z4435	1	DOOR RACK ANGLE-LEFT	HFD-2A
	D5-Z0285			HFD-3A
39	D5-Z4437	1	RACK ANGLE-LEFT	HFD-2A
	D5-Z0309			HFD-3A
40	D5-Z4436	1	DOOR RACK ANGLE-RIGHT	HFD-2A
	D5-Z0286			HFD-3A
41	D5-Z4438	1	RACK ANGLE-RIGHT	HFD-2A
	D5-Z0310			HFD-3A
42	D5-220055	1	PRETZEL SHAFT	HFD-2A
	D5-220058			HFD-3A
43	2B-Z7205	3	PRETZEL HOLDER	HFD-2A
	2B-Z7206	4		HFD-3A
44	2B-Z4279	3	PIZZA SHELF	HFD-2A
	2B-Z4280	4		HFD-3A
45	2B-Z8982	1	PIZZA SHAFT	HFD-2A
	2B-Z8983			HFD-3A

IMPORTANT: WHEN ORDERING, SPECIFY VOLTAGE OR TYPE GAS DESIRED
INCLUDE MODEL AND SERIAL NUMBER

PAGE 2
OF 2



Star Manufacturing International, Inc.

MODEL HFD2A and HFD3A HUMIDIFIED CABINET				
46	2C-Z0812	1	HAIRPIN	
47	2B-Z0289	3	SHELF	HFD-2A
	2B-Z0290	4		HFD-3A
48	2E-Z3393	1	UPPER WIRE HARNESS	HFD-2A
	2E-Z3394			HFD-3A
49	2N-Z3435	1	CARTRIDGE HEATER	120V
	2N-Z4149			230V
50	D5-Z3402	1	TOP WRAP - OPERATOR	HFD-2A
	D5-Z3411			HFD-3A
51	D5-Y9591	1	TOP WRAP - CUSTOMER	HFD-2A
	D5-Y9741			HFD-3A
52	1P-E1525		FOAM GASKET TAPE	
53	2E-43943		PROXIMITY SWITCH - DOOR	
54	2M-Z4187	1	TOP GRAPHIC LABEL - FRESH & FAST (not shown)	HFD-2A
	2M-Z4188			HFD-3A
55	2Q-Y9212	1	GLASS BACK	HFD-3A
56	D5-Z5881	1	RETAINER - DOOR GLASS	
57	D5-HFD015	1	PAN ASSEMBLY	HFD-2A
	D5-HFD016			HFD-3A
58	2C-08-07-0152	6	SCREW #6 X 3/8	