



STAR[®] **HOT FOOD HUMIDITY CABINET**

MODEL
HFD2A-120V/230V
HFD3A-120V/230V

Installation and Operation Instructions

2M-Z3437 Rev.P 7/19/2013



HFD2A



SAFETY SYMBOL



These symbols are intended to alert the user to the presence of important operating and maintenance instructions in the manual accompanying the appliance.

RETAIN THIS MANUAL FOR FUTURE REFERENCE NOTICE

Using any part other than genuine Star factory supplied parts relieves the manufacturer of all liability.

Star reserves the right to change specifications and product design without notice. Such revisions do not entitle the buyer to corresponding changes, improvements, additions or replacements for previously purchased equipment.

Due to periodic changes in designs, methods, procedures, policies and regulations, the specifications contained in this sheet are subject to change without notice. While Star International Holdings Inc., Company exercises good faith efforts to provide information that is accurate, we are not responsible for errors or omissions in information provided or conclusions reached as a result of using the specifications. By using the information provided, the user assumes all risks in connection with such use.

MAINTENANCE AND REPAIRS

Contact your local authorized service agent for service or required maintenance.

Please record the model number, serial number, voltage and purchase date in the area below and have it ready when you call to ensure a faster service.

Model No. _____

Serial No. _____

Voltage _____

Purchase Date _____

Authorized Service Agent Listing

Reference the listing provided with the unit

OR

for an updated listing go to:

Website: www.star-mfg.com
E-mail Service@star-mfg.com

Service Help Desk

Business Hours: 8:00 am to 4:30 p.m. Central Standard Time

Telephone: (314) 678-6303

Fax: (314) 781-2714

E-mail Parts@star-mfg.com
Service@star-mfg.com
Warranty@star-mfg.com

Website: www.star-mfg.com

Mailing Address: Star International Holdings Inc., Company
10 Sunnen Drive
St. Louis, MO 63143
U.S.A

SPECIFICATIONS

HFD-2A SERIES

- Capacity:** 72 large pretzels/bagels (P models), 3 16" pizzas (CR models)
3 Multipurpose Shelves, additional pizza shelves can be added
- Electrical:** 120 volt, 60 hertz, single phase, 1550 watts, 12.9 amps
230 volt, 60 hertz, single phase, 1550 watts, 6.7 amps
Cord Length - 6 ft.
Plug NEMA Spec - NEMA 5-15P (5-20P Canadian Models) (120V Models)
CEE7-7 (230V Models)
- Dimensions:** 21-1/8"W x 21-1/8"D x 34 - 1/2"H
(55.37 cm W x 55.37 cm D x 87.63 cm H)
-

HFD-3A SERIES

- Capacity:** 112 large pretzels/bagels (P models), 4 18" pizzas (CR models)
4 Multipurpose Shelves, additional pizza shelves can be added
- Electrical:** 120 volt, 60 hertz, single phase, 1800 watts, 15 amps
230 volt, 60 hertz, single phase, 1800 watts, 7.8 amps
Cord Length - 6 ft.
Plug NEMA Spec - NEMA 5-20P (120V Models)
CEE7-7 (230V Models)
- Dimensions:** 24-1/8"W x 28-1/8"D x 36"H
(61.28 cm W x 71.44 cm D x 91.44 cm H)
-

RECOMMENDED CONTROL SETTINGS AND HOLDING TIMES

Chefs, cooks and other specialized food service personnel employ varied methods of cooking. Proper holding temperatures for a specific food product must be based on the moisture content of the product, density, volume, and proper serving temperatures. Safe holding temperatures must also be correlated with palatability in determining the length of holding time for a specific product. The following are some recommended settings and holding times for products generally held in the cabinet.

See the control label or the Temperature and Humidity Control Operation section of this manual for instructions on changing the presets. Temperatures indicated on the cabinet display do not always match the product temperature.

PRODUCT TIME	PRESET NUMBER	PRESET SETTING	RECOMMENDED HOLDING
Pizza	1	(T-175°F, H-10)	1 Hour
Bread Products	2	(T-120°F, H-10)	3 Hours
Sandwiches	3	(T-170°F, H-6)	2 Hours
Chicken	4	(T-175°F, H-6)	5 Hours
General Use	5, 6	(T-150°F, H-5)	

GENERAL INSTALLATION INSTRUCTIONS



This equipment is designed and sold for commercial use only by personnel trained and experienced in its operation and is not sold for consumer use in and around the home nor for use directly by the general public in food service locations.

All shipping containers should be checked for freight damage both visible and concealed. This unit has been tested and carefully packaged to insure delivery of your unit in perfect condition. If equipment is received in damaged condition, either apparent or concealed, a claim must be made with the delivering carrier.

Concealed damage or loss - if damage or loss is not apparent until after equipment is unpacked, a request for inspection of concealed damage must be made with carrier within 15 days. Be certain to retain all contents plus external and internal packaging materials for inspection. The carrier will make an inspection and will supply necessary claim forms.

INSTALLATION

Each machine has been properly wired and inspected at the factory for operation on the voltage and type of current specified on the nameplate. Machines with a nameplate stamped 120V, are equipped for operation on 120 volt 60 hertz AC single phase service and must be connected to a separate 15 amp circuit with a 3 wire grounded, polarized receptacle. 230V models must be connected to a 230V, 60Hz, AC single phase service.

STAR Manufacturing recommends using TAP water for the best performance of your equipment.



DO NOT CONNECT TO ANY OTHER TYPE OF CURRENT SOURCE OR THE MACHINE WILL BE SERIOUSLY DAMAGED.

The guarantee of this machine covered by the warranty card does not apply if an improper installation has been made.



DO NOT BLOCK VENT HOLES ON TOP OF THE CABINET.

Fill Light - This is used as a reminder during start up. When the power switch is pushed on the fill light will illuminate to remind the operator to fill the reservoir. The fill light will go OFF when the reservoir is filled to the maximum.

Temperature and Humidity Control Operation -

- Fahrenheit or Celsius Selection** - The control will read cabinet air temperature in F° or C°. To change this indication press and hold the **MODE** switch and then press **+** to change the setting.
- Pre-set Selection** - This control comes from the factory with 6 programmed pre-set selections indicated as Preset 1, etc. These correspond to the temperature and humidity setting as indicated in the table below:

Cabinet Air		
Preset No.	Temp. Setting	Humidity Setting
1	175F°	10
2	120F°	10
3	170F°	6

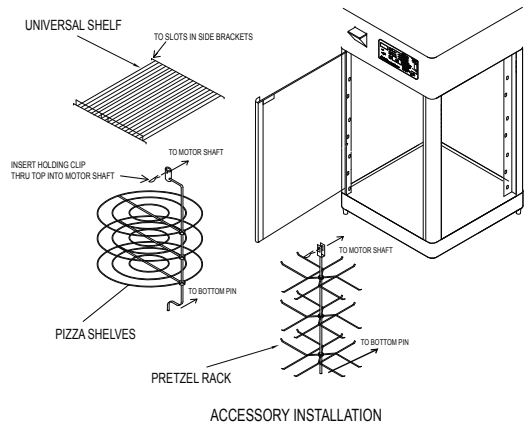

FIGURE 1

IL1028

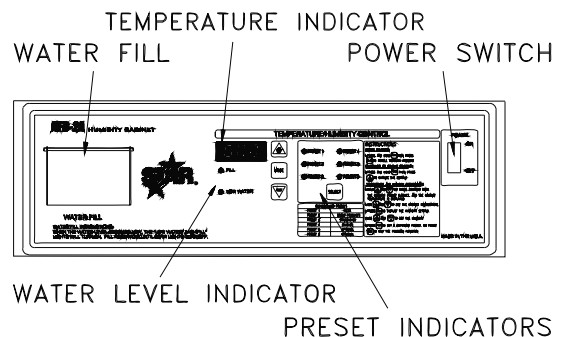

FIGURE 2

IL1033

GENERAL OPERATING INSTRUCTIONS

1. Install inside food rack or pizza/pretzel shelves depending on the model unit purchased. The shelves are in the enclosed accessory carton (See Figure 1).
2. **Plug the unit into a grounded 120 V.A.C. receptacle (230V receptacle for European models).**

LOCATION AND FUNCTION OF CONTROLS

The operating controls are located above the door on the side of the unit next to the water fill (See Figure 2).

1. Temperature Indicator - Displays temperature
2. Water Level Indicators - When ON water level is too low
3. ON/OFF Switch - Activates lights, digital thermometer and air circulation system.
4. Low Water Light - When the light is ON this indicates that water must be added. The fill light will also come on. Element shuts OFF until water is added.

4	175F°	6
5	150F°	5
6	150F°	5

To select Pre-Sets press and hold **MODE** then press **SELECT** to toggle through pre-sets. Stop on the desired pre-set setting. For specific food products, see the Recommended Control Settings and Holding Times section.

Temperature and Humidity Programming- A pre-set can be changed. Hold **+** and **-** for 3 seconds until the current temperature is displayed. Push **+** up or **-** down to set the desired cabinet temperature. Press **MODE** to display the humidity setting. Press **+** up or **-** down to set the desired humidity level. A setting of 5 will be about 25% relative humidity. Press **MODE** to leave program.

By pressing and holding **MODE** and then **SELECT** different pre-sets can be individually chosen and reset to a specific temperature and humidity setting.
(Maximum temperature is 175°F and humidity 10).

NOTE

Using tap water will promote scaling that will eventually cause clogging of water tubes and prevent the proper operation of the Humidity Cabinet. The use of distilled water will prevent scaling inside the water lines of the cabinet.

5. Fill reservoir by lifting reservoir lid and pouring water in until both the fill and low water light should be "OFF" when the tank is full. HFD-2A holds approximately 3 quarts and HFD-3A holds approximately 5 quarts. Both lights will be off until the water level drops below a specified set level and the low water light comes on. The water heater will stop operating until water is added. The fill light will be "ON" until the water level reaches the fill water indicator probe. 5 quarts. Both lights will be off until the water level drops below a specified set level and the low water light comes on. The water heater will stop operating until water is added. The fill light will be "ON" until the water level reaches the fill water indicator probe.

OPERATING PROCEDURES

1. Turn power switch on.
2. Set desired temperature and humidity or desired pre-set. Allow approximately 20 minutes for machine to reach proper temperature. (Time will vary depending on temperature setting.)
3. Fill water reservoir.
4. Monitor cabinet temperature via the digital thermometer on the control (See Figure 2).
5. Periodically monitor water level by indicator on control panel (See Figure 2).

DOOR REVERSAL

Doors are supplied from the factory mounted on the left side of the cabinet but can be mounted on the right side by following the instructions listed below.

DOOR REMOVAL (See Figure 3)

1. Remove the top left mounting bracket while holding door. Replace screws in holes. Keep the bracket for installation on the right side.
2. Lift door carefully off of bottom pin bracket and set down.
3. Remove the bottom pin bracket by removing the 2 bottom screws. Replace screws in holes. Keep the bracket for installation on the right side.
4. For models using the rotating pizza or pretzel racks only, remove the rectangular bracket magnet assembly in the upper right corner of the door being careful not to crack glass. Slide a razor under to break adhesive. Keep this assembly because this will be located in a new position after the door is moved.

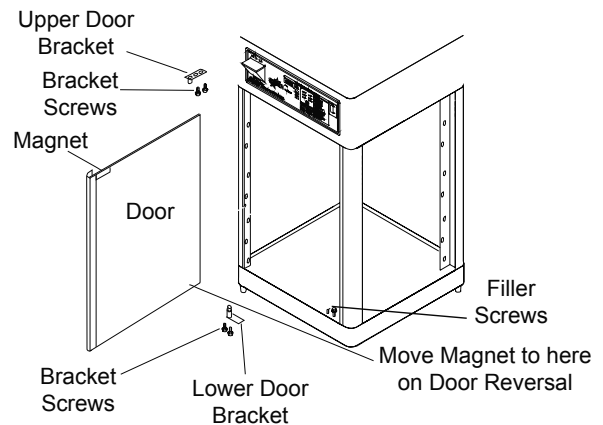

FIGURE 3

IL1034

DOOR INSTALLATION (See Figure 3)

1. Remove the 2 bottom and 2 top screws on the right side of cabinet door opening.
2. Mount the bottom "taller" mounting pin first and screw in place using the 2 screws removed earlier.
3. Mount the bottom door hinge hole into the bottom pin, while holding door. The handle should be on the outside of door on the left side of the unit.
4. Locate the top mounting pin into top door hinge hole. Slide the top bracket into place, holding door, and attach top bracket using the 2 screws removed earlier.
5. Check door for proper alignment in opening. Door can be adjusted slightly up and down by sliding the lower bracket back or forth. Door can be adjusted slightly in and out of cabinet by adjusting top bracket in and out. Tighten all door mounting screws securely.
6. For rotating models, locate the magnet assembly at the top right hand corner of the installed door. Use RTV silicone to hold it in place. Check for rotisserie operation by opening and closing door.

CLEANING INSTRUCTIONS

DISCONNECT ELECTRICAL CORD BEFORE CLEANING THE CABINET

1. To maintain finish and shine of unit, wipe daily with a damp cloth and mild soap. Do not use harsh detergents or scouring pads.
2. Daily cleaning of inside glass, bottom pan and racking system with a damp cloth is required.

BE SURE CABINET HAS COOLED DOWN PRIOR TO OPENING DRAIN TO AVOID BURNING FINGERS WHILE UNSCREWING PLUG.

3. It is required that the water reservoir be drained daily and re-filled with fresh water. This can be done by placing a 5 quart container under the drain plug and un-screwing the drain plug.



TROUBLE SHOOTING GUIDE

This guide is recommended for use by a qualified service technician familiar with electrical commercial equipment.

1. Unit does not operate.

- Be sure unit is plugged into correct supply voltage.
- Be sure power switch is turned on.
- Disconnect power cord and check power switch and wiring connections for bad connections.

2. Unit turns on but unit light or blower does not come on. Blower and light should always be on whenever unit is energized.

- If the light is not on, check and replace the light bulb with a standard 75 watt bulb.
- If the blower is not on, turn off power switch and disconnect power cord. Check wiring to blower motor. Check motor to see if it turns freely. Check motor and replace blower if showing an open circuit on continuity test.

3. Center rotisserie motor does not work. Motor will turn only when door is closed completely.

- Check for door magnet on top door glass. This energizes a proximity switch in the unit when the door is closed. If it is not there it must be replaced to energize motor. If it is there and motor does not work, try repositioning on door glass to energize motor. If this fails then check rotisserie motor and wire connections. Also check proximity switch by doing a continuity check on switch with door closed. If switch is working on a closed door then the rotisserie motor must be checked and replaced if necessary.

4. Unit turns on, everything works but cabinet does not heat up.

- Check electronic control on top front of unit. Verify that the unit is set for a warmer air temperature than room temperature. Set it for 140°.
- If unit does not heat up after several minutes, several things must be checked to determine the cause.
 - With the control set at 140°F, check the power to the air heater element relay from the control board. It should be about 12 V.D.C. to the relay coil. If it is then the board and the air temperature thermistor sensor are working. If not then the sensor and board must be checked. The sensor should read about 4,000-5,000 ohms at room temperature. Resistance on the probe will drop as the temperature increases. If it reads open then replace it. To check the board, install a 5,000 ohm 1/2 watt resistor for the suspect sensor. The board should supply 12 V.D.C. power to the relay. If it doesn't, then the board is defective.
 - If the relay is getting energized by the board and the air heater element is still not working, check the voltage out of the power side of the relay. It should be 0 VAC. If not, then replace the relay.
- If relay is working and the wiring is all intact and tightly connected, check the heating element.
- Disconnect heating element and check for continuity. You should measure a low ohms reading like 15-20 ohms. If nothing, then replace heating element.

5. Unit turns on, everything works but water heater does not work.

- Check electronic control. Verify that the humidity setting is set for a value of 10 to check control.
- Be sure water tank is filled with water and the water fill light is off.
- With the unit operating for several minutes the water in the fill should be getting warm. If not then troubleshoot the water heating element following the same steps in 4a. and 4b. on the previous page, except on the water heater relay, sensor and heating element.

6. Unit turns on, everything works, but the low water light is on. When the low water light is on and blinking there will be no voltage to the relay or water heating element.

- Check and make sure unit is full of water. If yes, then shut off the power switch and disconnect power cord. Remove top and check the water sensor board (3 connections on water tank). Remove sensor board and verify the 2 sensor rods are attached to the underside of board. The long rod should be attached to the terminal connector marked "L" for low water indicator. The short rod to the "H" terminal for high water. The green ground wire must be attached to the "G" connection. Using a fine sandpaper, sand both sensing rods to remove any corrosive buildup. Re-attach the sensor assembly securely using the screws removed. Be sure wires are attached and routed back correctly to the marked control board terminals. Re-attach the top and energize unit. Low water light should be off. If not, then control board is not functioning properly and should be replaced.

THOROUGHLY INSPECT YOUR UNIT ON ARRIVAL

This unit has been tested for proper operation before leaving our plant to insure delivery of your unit in perfect condition. However, there are instances in which the unit may be damaged in transit. In the event you discover any type of damage to your product upon receipt, you must immediately contact the transportation company who delivered the item to you and initiate your claim with same. If this procedure is not followed, it may affect the warranty status of the unit.

LIMITED EQUIPMENT WARRANTY

All workmanship and material in Star products have a one (1) year limited warranty on parts & labor in the United States and Canada. Such warranty is limited to the original purchaser only and shall be effective from the date the equipment is placed in service. Star's obligation under this warranty is limited to the repair of defects without charge, by the factory authorized service agency or one of its sub-agencies. Models that are considered portable (*see below*) should be taken to the closest Star service agency, transportation prepaid.

- > Star will not assume any responsibility for loss of revenue.
- > On all shipments outside the United States and Canada, see International Warranty.
- * The warranty period for the Ultra-Max, Hot Plates, Griddles, Charbroilers is (3) years parts & labor.
- * The warranty period for the Star-Max, Charbroilers, Griddles, Hot Plates, Fryers & Finishing Oven is (2) years parts & labor.
- * The warranty period for the JetStar six (6) ounce & Super JetStar eight (8) ounce series popcorn machines is two (2) years.
- * The warranty period for the Chrome-Max Griddles is five (5) years on the griddle surface. See detailed warranty provided with unit.
- * The warranty period for Teflon/Dura-Tec coatings is one year under normal use and reasonable care. This warranty does not apply if damage occurs to Teflon/Dura-Tec coatings from improper cleaning, maintenance, use of metallic utensils, or abrasive cleaners, abrasive pads, product identifiers and point-of-sale attachments, or any other non-food object that comes in continuous contact with the roller coating. This warranty does not apply to the "non-stick" properties of such materials.
- > This warranty does not apply to "Special Products" but to regular catalog items only. Star's warranty on "Special Products" is six (6) months on parts and ninety (90) days on labor.
- > This warranty does not apply to any item that is disassembled or tampered with for any purpose other than repair by a Star Authorized Service Center or the Service Center's sub-agency.
- > This warranty does not apply if damage occurs from improper installation, misuse, wrong voltage, wrong gas or operated contrary to the Installation and Operating instructions.
- > This warranty is not valid on Conveyor Ovens *unless* a "start-up/check-out" has been performed by a Factory Authorized Technician.

PARTS WARRANTY

Parts that are sold to repair out of warranty equipment are warranted for ninety (90) days. The part only is warranted, the labor to replace the part is **NOT** warranted.

SERVICES NOT COVERED BY WARRANTY

1. Travel time and mileage rendered beyond the 50 mile radius limit
2. Mileage and travel time on portable equipment (*see below*)
3. Labor to replace such items that can be replaced easily during a daily cleaning routine, ie; removable kettles on fryers, knobs, grease drawers on griddles, etc.
4. Installation of equipment
5. Damages due to improper installation
6. Damages from abuse or misuse
7. Operated contrary to the Operating and Installation Instructions
8. Cleaning of equipment
9. Seasoning of griddle plates
10. Voltage conversions
11. Gas conversions
12. Pilot light adjustment
13. Miscellaneous adjustments
14. Thermostat calibration and by-pass adjustment
15. Resetting of circuit breakers or safety controls or reset buttons
16. Replacement of bulbs
17. Replacement of fuses
18. Repair of damage created during transit, delivery, & installation OR created by acts of God

PORTABLE EQUIPMENT

Star will not honor service bills that include travel time and mileage charges for servicing any products considered "Portable" including items listed below. These products should be taken to the Service Agency for repair:

- * The Model 510FD, 510FF Fryer.
- * The Model 526TOA Toaster Oven.
- * The Model J4R, 4 oz. Popcorn Machine.
- * The Model 518CMA & 526CMA Cheese Melter.
- * The Model 12MC & 15MC & 18MCP Hot Food Merchandisers.
- * The Model 12NCPW & 15NCPW Nacho Chip/Popcorn Warmer.
- * All Hot Dog Equipment **except Roller Grills & Drawer Bun Warmers.**
- * All Nacho Cheese Warmers **except Model 11WLA Series Nacho Cheese Warmer.**
- * All Condiment Dispensers **except the Model HPD & SPD Series Dispenser.**
- * All Specialty Food Warmers **except Model 130R, 11RW Series, and 11WSA Series.**
- * All QCS/RCS Series Toasters **except Model QCS3 & RCS3 Series.**
- * All Fast Steamer Models **except Direct Connect Series.**

ALL:

- * Pop-Up Toasters
- * Butter Dispensers
- * Pretzel Merchandisers
(Model 16PD-A Only)
- * Pastry Display Cabinets
- * Nacho Chip Merchandisers
- * Accessories of any kind
- * Sneez Guards
- * Pizza Ovens
(Model PO12 Only)
- * Heat Lamps
- * Pumps-Manual

The foregoing warranty is in lieu of any and all other warranties expressed or implied and constitutes the entire warranty.

FOR ASSISTANCE

Should you need any assistance regarding the Operation or Maintenance of any Star equipment; write, phone, fax or email our Service Department. In all correspondence mention the Model number and the Serial number of your unit, and the voltage or type of gas you are using.

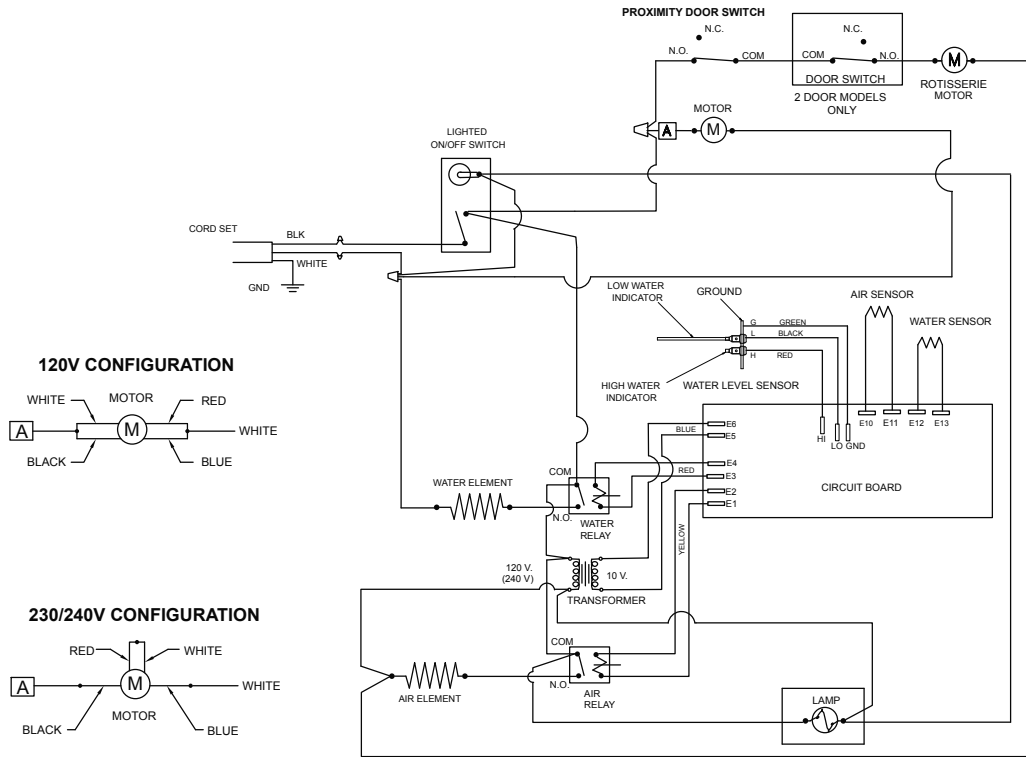

MODEL: HFD-2A

THIS DRAWING CONTAINS INFORMATION CONFIDENTIAL TO STAR MFG. INT'L. INC.
NO REPRODUCTION OR DISCLOSURE OF ITS CONTENTS IS PERMITTED.

STAR MANUFACTURING INTERNATIONAL INC.

SK1812

Rev C

10/06/2005

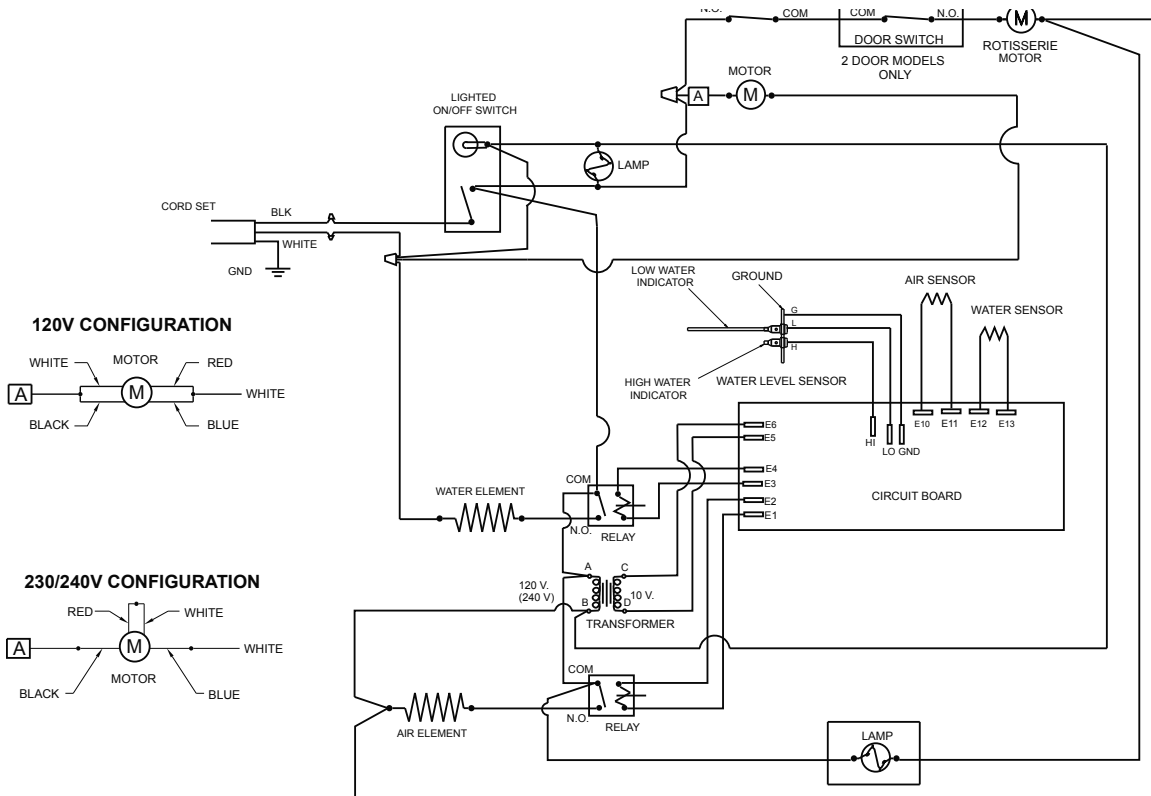

MODEL: HFD-3A

THIS DRAWING CONTAINS INFORMATION CONFIDENTIAL TO STAR MFG. INT'L. INC.
NO REPRODUCTION OR DISCLOSURE OF ITS CONTENTS IS PERMITTED.

STAR MANUFACTURING INTERNATIONAL INC.

SK1813

Rev B

05/06/2002

INSTALLATION OF RACKS ON HFD-2 MODELS

← FRD TO CONTROL PANEL

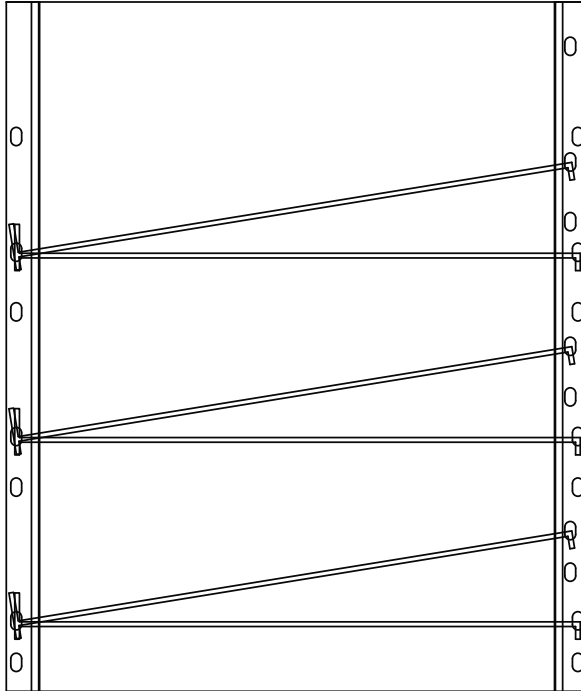

INSTALLATION OF 3 RACKS

← FRD TO CONTROL PANEL

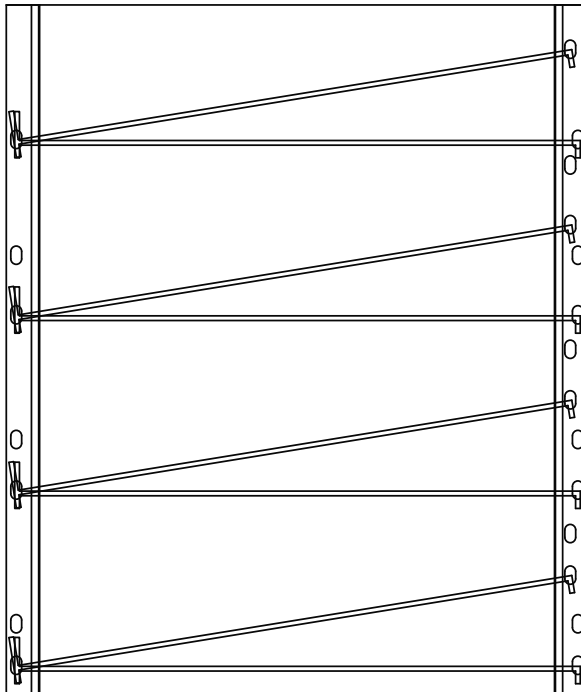

INSTALLATION OF 4 RACKS

SOME ITEMS ARE INCLUDED FOR ILLUSTRATIVE PURPOSES ONLY AND IN CERTAIN INSTANCES MAY NOT BE AVAILABLE



MODEL: HFD-2

THIS DRAWING CONTAINS INFORMATION CONFIDENTIAL TO STAR MFG. INT'L. INC.
NO REPRODUCTION OR DISCLOSURE OF ITS CONTENTS IS PERMITTED.

STAR MANUFACTURING INTERNATIONAL INC.

SK1858

Rev -

04/26/2001

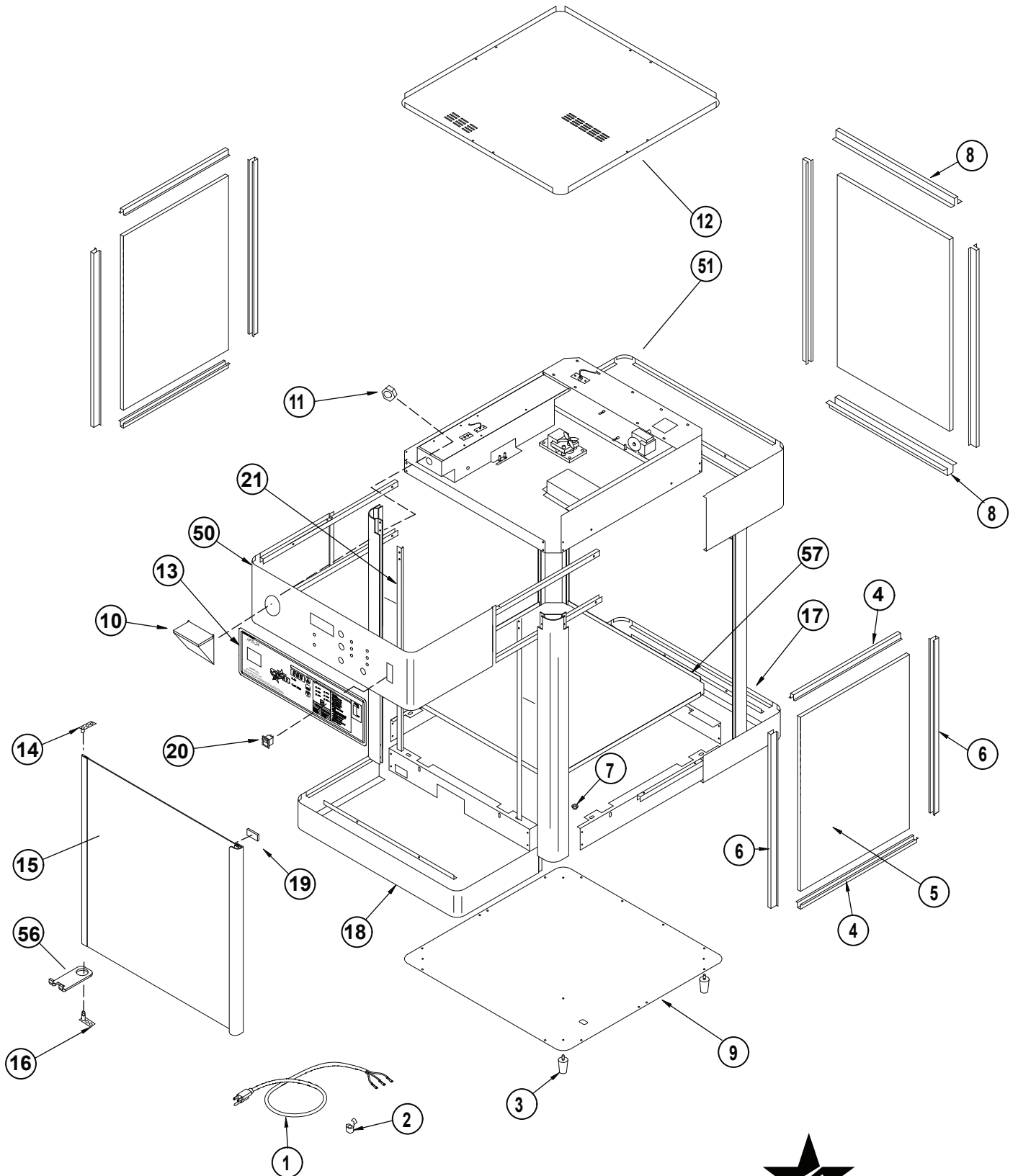

This drawing contains information confidential to Star Manufacturing International, Inc. No reproduction or disclosure of its contents is permitted.

SOME ITEMS ARE INCLUDED FOR ILLUSTRATIVE PURPOSES ONLY AND IN CERTAIN INSTANCES MAY NOT BE AVAILABLE



MODEL: HFD-2A,-3A

STAR MANUFACTURING INTERNATIONAL, INC.

SK1714

Rev. A

10/30/2012

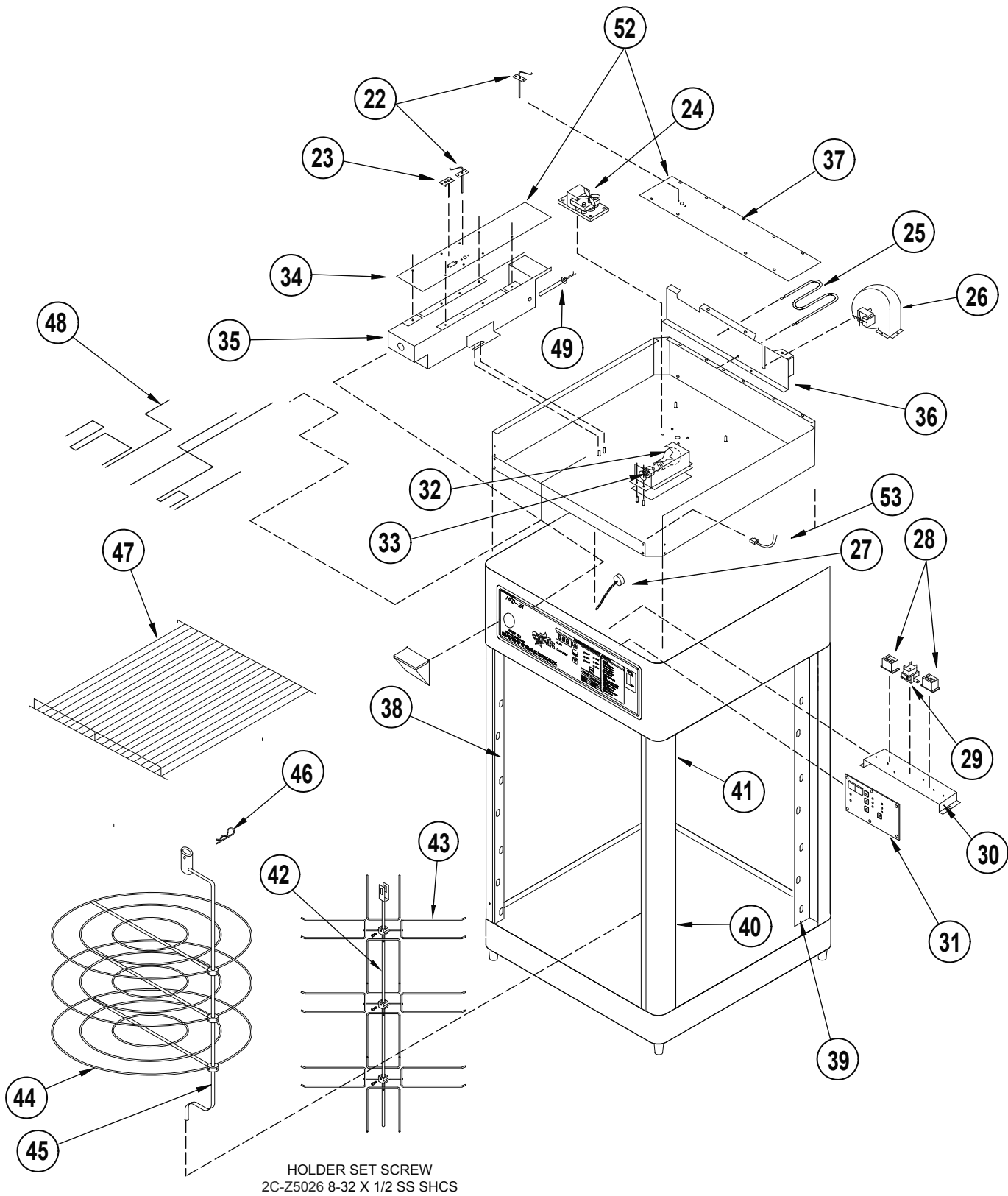

This drawing contains information confidential to Star Manufacturing International, Inc. No reproduction or disclosure of its contents is permitted.

SOME ITEMS ARE INCLUDED FOR ILLUSTRATIVE PURPOSES ONLY AND IN CERTAIN INSTANCES MAY NOT BE AVAILABLE



STAR MANUFACTURING INTERNATIONAL, INC.

MODEL: HFD-2A,-3A 120V/230V

SK1375

REV. F

5-09-11

PARTS LIST

August 14, 2013, Rev. P

MODEL HFD2A and HFD3A HUMIDIFIED CABINET				
Fig No	Part No	Qty	Description	Application
1	C3-G8021	1	CORD ASSEMBLY	HFD-2A
	2E-05-07-0169			HFD-3A
	A4-120165			230V
2	2K-Y2967	1	BUSHING - HEYCO 7K-2 BLK	
3	2A-6904	4	FOOT	
4	D5-Y9623	4	GLASS CHANNEL	HFD-2A
	2I-Y7838			HFD-3A
5	2Q-Y9567	2	GLASS - SIDE	HFD-2A / -2APT
	2Q-Y9110			HFD-3A / -3APT
	2Q-Y9121	1	GLASS - BACK	HFD-3A
6	D5-Y9624	6	GLASS CHANNEL	HFD-2A
	2I-Y7840			HFD-3A
7	2K-Y1139	1	BUSHING - HEYCO	
8	2I-Y7839	2	GLASS CHANNEL-TOP AND BOTTOM	HFD-3A
9	D5-220038	1	BOTTOM ASSEMBLY	HFD-2A
	D5-220029			HFD-3A
10	D5-HFD004	1	WATER FILL ASSEMBLY	
11	2C-Z3389	1	NUT, WATER FILL ASSEMBLY	
12	D5-Z3401	1	TOP COVER	HFD-2A
	D5-Z3409			HFD-3A
13	2M-Z4180	1	LABEL-OPERATOR PANEL	HFD-2A
	2M-Z4181			HFD-3A
14	D5-HFD014		TOP DOOR BRACKET ASSEMBLY	
15	D5-HFD032	1	GLASS DOOR ASSEMBLY w/ MAGNET	HFD-2A / -2APT
	D5-HFD033			HFD-3A / -3APT
NI	2R-Z3494		MAGNET STRIP, DOOR	
16	D5-HFD017		BOTTOM DOOR BRACKET ASSEMBLY	
17	D5-Z3573	1	BOTTOM REAR - CUSTOMER	HFD-2A
	D5-Z3418			HFD-3A
18	D5-Z3417	1	BOTTOM WRAP - OPERATOR	HFD-2A
	D5-Z3574			HFD-3A
19	D5-HFD034		DOOR SWITCH BRACKET & MAGNET	
20	2E-Z12327	1	SWITCH, SPST NON-LIGHTED	
	PS-HFD041	KIT	HFD-2A ON/OFF LIGHTED SWITCH REPL. KIT	HFD-2A
	PS-HFD042		HFD-3A ON/OFF LIGHTED SWITCH REPL. KIT	HFD-3A
21	D5-Z3729	1	DOOR STOP FILLER	HFD-2A
	D5-Z3730			HFD-3A
22	2E-Z3236	2	THERMISTER SENSOR	
23	D5-HFD003	1	WATER LEVEL SENSOR ASSEMBLY	
24	D5-Z17319	1	ROTISSERIE MOTOR (120V), Fan Blade Not Included	
	2U-Z3642		ROTISSERIE MOTOR (230V), Fan Blade Not Included	
NI	2U-Z9811	1	FAN BLADE, MOTOR	
25	2N-Y9145	1	AIR HEATER (120V)	HFD-2A
	2N-Z0628		AIR HEATER (230V)	HFD-2A
	2N-Z3678		AIR HEATER (120V)	HFD-3A
	2N-Z4150		AIR HEATER (230V)	HFD-3A
26	2U-Z3412	1	BLOWER (120V/230V)	
27	A3-35219	1	CAP AND CHAIN	
28	2E-05-07-0352	2	RELAY	
29	2E-05-07-0351	1	TRANSFORMER	120V
	2E-05-07-0350			230V

**IMPORTANT: WHEN ORDERING, SPECIFY VOLTAGE OR TYPE GAS DESIRED
INCLUDE MODEL AND SERIAL NUMBER**

PAGE 1
OF 2



Star Manufacturing International, Inc.

PARTS LIST

August 14, 2013, Rev. P

MODEL HFD2A and HFD3A HUMIDIFIED CABINET				
Fig No	Part No	Qty	Description	Application
30	D5-Z3543	1	CONTROL MOUNTING BRACKET	
31	2E-Z3287	1	CONTROL BOARD (120V/230V)	
32	2S-Z3608	1	BULB - STANDARD 75 WATT (120V)	120V
	2S-Z0630		BULB - STANDARD 100 WATT (230V)	230V
33	2E-Y9184	1	SOCKET	
34	D5-Z3396	1	COVER RESERVOIR	HFD-2A
	D5-Z3406			HFD-3A
35	D5-HFD007	1	RESERVOIR ASSEMBLY	HFD-2A
	D5-HFD008			HFD-3A
36	D5-Z3399	1	FRONT AIR DUCT	HFD-2A
	D5-Z3410			HFD-3A
37	D5-Z3400	1	COVER AIR DUCT	HFD-2A
	D5-Z3408			HFD-3A
38	D5-Z4435	1	DOOR RACK ANGLE-LEFT	HFD-2A
	D5-Z0285			HFD-3A
39	D5-Z4437	1	RACK ANGLE-LEFT	HFD-2A
	D5-Z0309			HFD-3A
40	D5-Z4436	1	DOOR RACK ANGLE-RIGHT	HFD-2A
	D5-Z0286			HFD-3A
41	D5-Z4438	1	RACK ANGLE-RIGHT	HFD-2A
	D5-Z0310			HFD-3A
42	2A-220055	1	PRETZEL SHAFT	HFD-2A
	2A-220058			HFD-3A
43	2B-Z7205	3	PRETZEL HOLDER	HFD-2A
	2B-Z7206			4
44	2B-Z4279	3	PIZZA SHELF	HFD-2A
	2B-Z4280	4		HFD-3A
45	2B-Z8982	1	PIZZA SHAFT	HFD-2A
	2B-Z8983			HFD-3A
46	2C-Z0812	1	HAIRPIN	
47	2B-Z0289	3	SHELF	HFD-2A
	2B-Z0290	4		HFD-3A
48	2E-Z3393	1	UPPER WIRE HARNESS	HFD-2A
	2E-Z3394			HFD-3A
49	2N-Z3435	1	CARTRIDGE HEATER	120V
	2N-Z4149			230V
50	D5-Z3402	1	TOP WRAP - OPERATOR	HFD-2A
	D5-Z3411			HFD-3A
51	D5-Y9591	1	TOP WRAP - CUSTOMER	HFD-2A
	D5-Y9741			HFD-3A
52	1P-E1525		FOAM GASKET TAPE	
53	2E-43943		PROXIMITY SWITCH - DOOR	
54	2M-Z4187	1	TOP GRAPHIC LABEL - FRESH & FAST (not shown)	HFD-2A
	2M-Z4188			HFD-3A
55	2Q-Y9212	1	GLASS BACK	HFD-3A
56	D5-Z5881	1	RETAINER - DOOR GLASS	
57	D5-HFD015	1	PAN ASSEMBLY	HFD-2A
	D5-HFD016			HFD-3A

IMPORTANT: WHEN ORDERING, SPECIFY VOLTAGE OR TYPE GAS DESIRED
INCLUDE MODEL AND SERIAL NUMBER

PAGE 2
OF 2



Star Manufacturing International, Inc.

STAR INTERNATIONAL HOLDINGS INC. COMPANY

Star - Holman - Lang - Wells - Bloomfield - Toastmaster

10 Sunnen Drive, St. Louis, MO 63143 U.S.A.

(314) 678-6303

www.star-mfg.com