

2M-Z11612 HSCO TURBO-MAX ELECTRIC SPEED CONVEY OVEN

Model: HSCO High Speed Conveyor Oven, Main Assy



SK2370 Rev. C 8/23/12

# PARTS LIST

April 9, 2012, Rev. B

TURBO-MAX CONVEYOR OVEN, MAIN ASSEMBLY				
Fig No	Part No	Qty	Description	Application
1	B6-SC0001	1	COVER - SCO-1420	HSC014
	B6-SC0032		COVER - SCO 1624	HSC016
2	2C-200014	36	SCREW 8-32X3/8 THP SS	
3	B6-Z10550	1	CONTROL COVER, RIGHT	
4	B6-Z10548	1	CONTROL COVER, LEFT	
5	B6-Z13421	4	BLOCKOFF PLATE	HSC016P
6	B6-Z10566	2	COL. PLATE, SCO - FULL	HSC014
	B6-Z11793		COL. PLATE, 1624 - FULL	HSC016
7	B6-Z10565	2	NOZZLE, SCO - FULL	HSC014
	B6-Z11792		NOZZLE , 1624 - FULL	HSC016
8	2C-Z5182	6	SCREW 1/4-20X1/2 THUMB	HSC014
9	B6-Z11269	2	TUNNEL SHROUD (EYEBROW)	HSC014
	B6-Z11798			HSC016
10	B6-Z10574	1	CRUMB TRAY, RIGHT	HSC014
	B6-Z11794		CRUMB TRAY, RIGHT - 1624	HSC016
11	2C-Z6925	22	SCREW #8X1/2 HEXW B SS	
12	2N-Z10579	3	ELEMENT, METAL - AIR HEAT	HSC014
	2N-Z11760			HSC016
13	2N-Z11503	6	ELEMENT, METAL - TOASTING	HSC014
	2N-Z11761		ELEMENT, METAL - TOASTING	HSC016
14	B6-Z11570	6	ELEMENT COVER PLATE	
15	2J-Z5189	1	THERMOCOUPLE ASSEMBLY	
16	2C-Z3350	3	HALF CLAMP .188 D STL ZP	
17	B6-SC0009	1	FRONT PANEL ASSY - 1420	HSC014
	B6-SC0037		FRONT PANEL ASSY - 1624	HSC016
18	B6-Z13422	2	RETURN BLOCKOFF PLATE	HSC016P
19	B6-SC0014	1	CONVEYOR ASSEMBLY	HSC014
	B6-SC0036		CONVEYOR ASSEMBLY - 1624	HSC016
20	B6-Z11265	2	WIREWAY, BOTTOM - SCO	HSC014
	B6-Z11797		WIREWAY, BOTTOM - SCO	HSC016
21	B6-Z10582	1	COOLING DUCT	HSC014
	B6-Z11791		COOLING DUCT, SCO1624	HSC016
22	2A-Z0314	4	FOOT, 4 IN DIE CAST	
23	2C-Y5567	1	SET SCREW 10-24X.125	
24	2A-Z8633	1	DRIVE COG	
25	2C-Z5555	4	BOLT 1/4-20 X .75 HEX SS	
26	2C-Z5557	4	WASHER 1/4 SPLIT SS	
27	B5-Z8661	1	GEAR MOTOR COVER PLATE	
28	B6-Z10575	1	CRUMB TRAY, LEFT	HSC014
	B6-Z11795		CRUMB TRAY, LEFT - 1624	HSC016
29	B6-Z10511	1	CRUMB TRAY, BOTTOM	HSC014
	B6-Z11796		CRUMB TRAY, BOTTOM - 1624	HSC016
30	2U-Z10407	1	GEARMOTOR - 40:1 BROTHER - INCLUDES RUN CAPACITOR	
31	B6-Z10596	1	GEARMOTOR FASTENER BRACKET	
32	2E-Z10585	1	CORD ASSEMBLY #8 15-50	240V
33	2C-200262	2	NUT, WELD, 1/4 IN.	
34	B6-SC0003	1	FAN PLUG ASSEMBLY	
35	B6-Z10583	1	ACCESS DOOR, LEFT REAR	
36	B6-Z10577	1	ACCESS DOOR, RIGHT REAR	
37	B6-SC0024	1	REAR PANEL ASSEMBLY- 1420	HSC014
	B6-SC0031		REAR PANEL ASSEMBLY- 1624	HSC016
	B6-SC0041		REAR COVER ASY-HSC016 230V	HSC016-230V
38	2R-Z11567	1	GUARD, FAN - WIRE	
39	2C-Z2594	2	NUT 6-32 HEX W STL NP	
40	B6-Z15052	1	TERMINAL BOX ASSY	HSC016-230V
41	2E-200472	5	TERMINAL BLOCK LG 222	HSC016-230V
	2E-200473	1	TERMINAL BLOCK END LG 230	HSC016-230V
42	B6-Z15055	1	TERMINAL BLOCK COVER	HSC016-230V
43	B6-SC0043	1	DISCHARGE SANDWICH SHELF	HSC016Q-230V

2M-Z111612 HSCO TURBO-MAX ELECTRIC SPEED CONVEY OVEN

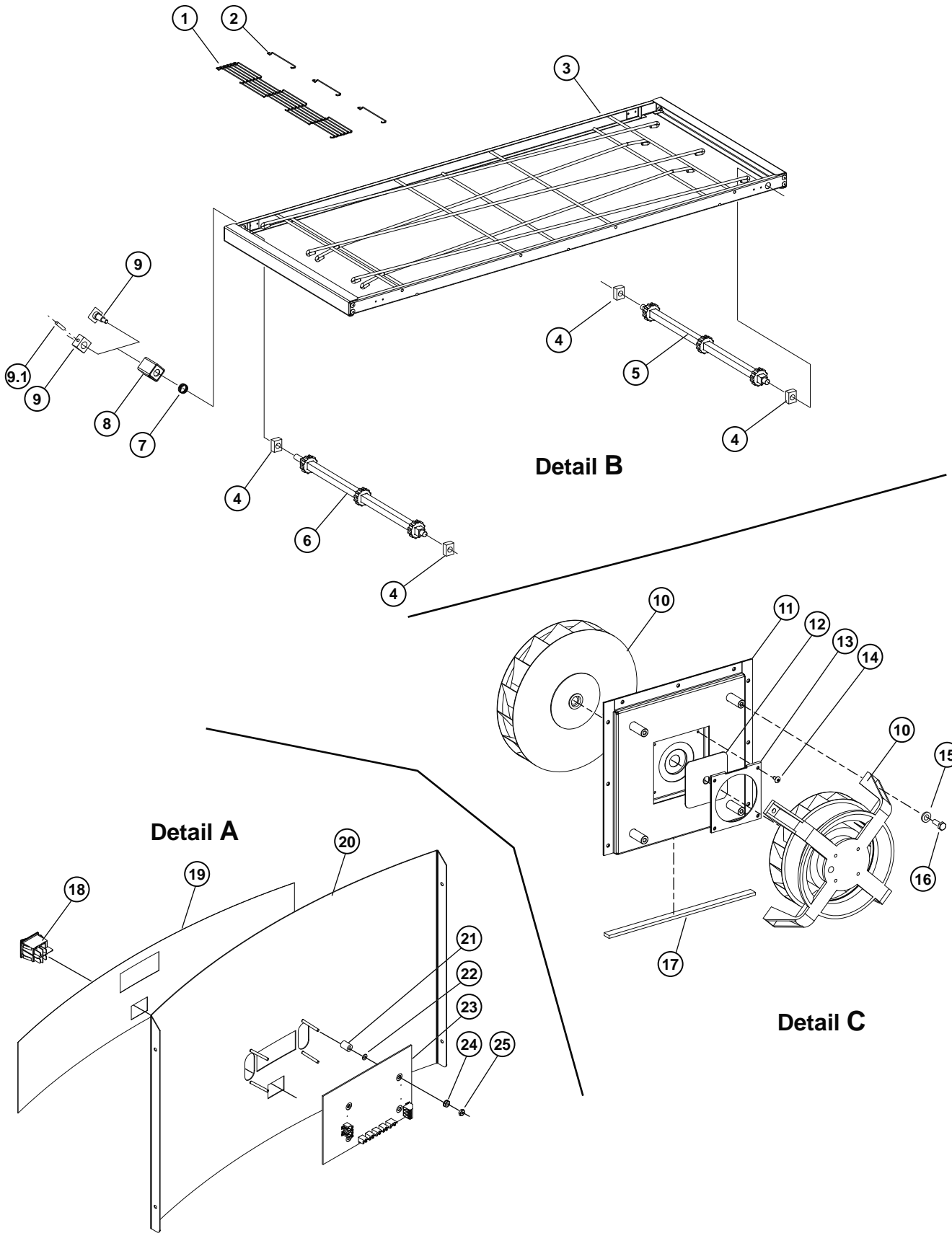

2M-Z11612 HSCO TURBO-MAX ELECTRIC SPEED CONY OVEN

# PARTS LIST

August 19, 2011, Rev. B

TURBO-MAX CONVEYOR OVEN DETAILS A, B & C				
Fig No	Part No	Qty	Description	Application
1	2B-Z10516-2	1	CONVEYOR BELT SEGMENT 72"	HSC014
	2B-Z11833-2			HSC016
2	2B-Z10516-1	3	BELT CLIP, SINGLE SPACE	HSC014
	2B-Z11833-1	5		HSC016
3	B6-SC0006	1	CONVEYOR WELDMENT	HSC014
	B6-SC0035		CONVEYOR WELDMENT - 1624	HSC016
4	2P-Z5168	4	BEARING, OVEN CONVEYOR	
5	2A-SC0013	1	IDLER ASSEMBLY	HSC014
	2A-SC0034		IDLER ASSEMBLY - 1624	HSC016
6	2A-Z13691	1	DRIVESHAFT ASSEMBLY - HSC014	HSC014
	2A-Z13692		DRIVESHAFT ASSEMBLY - HSC016	HSC016
<i>NEEDS 2A-Z13646 &amp; 2C-Z13647</i>				
7	2P-Z9051	1	SPRING-COUPLING	
8	B5-LC0013	1	COUPLING ASSY	
9	B6-SC0022	1	RETAINER DRIVE COG	
	2A-Z13646		DRIVEN COG, UNITS BUILT AFTER 7/2010	UNITS AFTER: COE3607100001 & COE4007100001
9.1	2C-Z13647	ROLL PIN 1/8 X 3/4, UNITS BUILT AFTER 7/2010		
10	2U-Z5710	1	HOT AIR BLOWER, 230V - COMES WITH 2E-Z7511 CAPACITOR	
11	B6-SC0002	1	FAN PLUG WELDMENT	
12	2I-Z10509	1	SEAL, AIR - FAN SHAFT	
13	B6-Z10510	1	AIR SEAL RETAINER	
14	2C-6349	4	SCREW #8X3/8 B THP STL NP	
15	2C-Z5557	4	WASHER 1/4 SPLIT SS	
16	2C-Z5555	4	BOLT 1/4-20 X .75 HEX SS	
17	1P-E1523	1	TAPE SILICONE TYPE S618	
18	2E-Z11661	1	SWITCH, DPST - BLACK	
19	2M-Z10597	1	LABEL, DIAGRAM - SCO	
20	B6-Z10532	1	FRONT PANEL - 1420	HSC014
	B6-Z11831		FRONT PANEL - SCO 1624	HSC016
21	2A-Z3429	4	SPACER-NYLON .175X.375X.5	
22	2C-Z11541	8	WASHER, FLAT - #6 NYLON	
23	PS-Z11960	1	CONTROLLER, SCO	
24	2C-Z2594	4	NUT 6-32 HEX W STL NP	
25	2C-2553	4	NUT 6-32 HEX STL NP	

2M-Z111612 HSCO TURBO-MAX ELECTRIC SPEED CONVEYOR



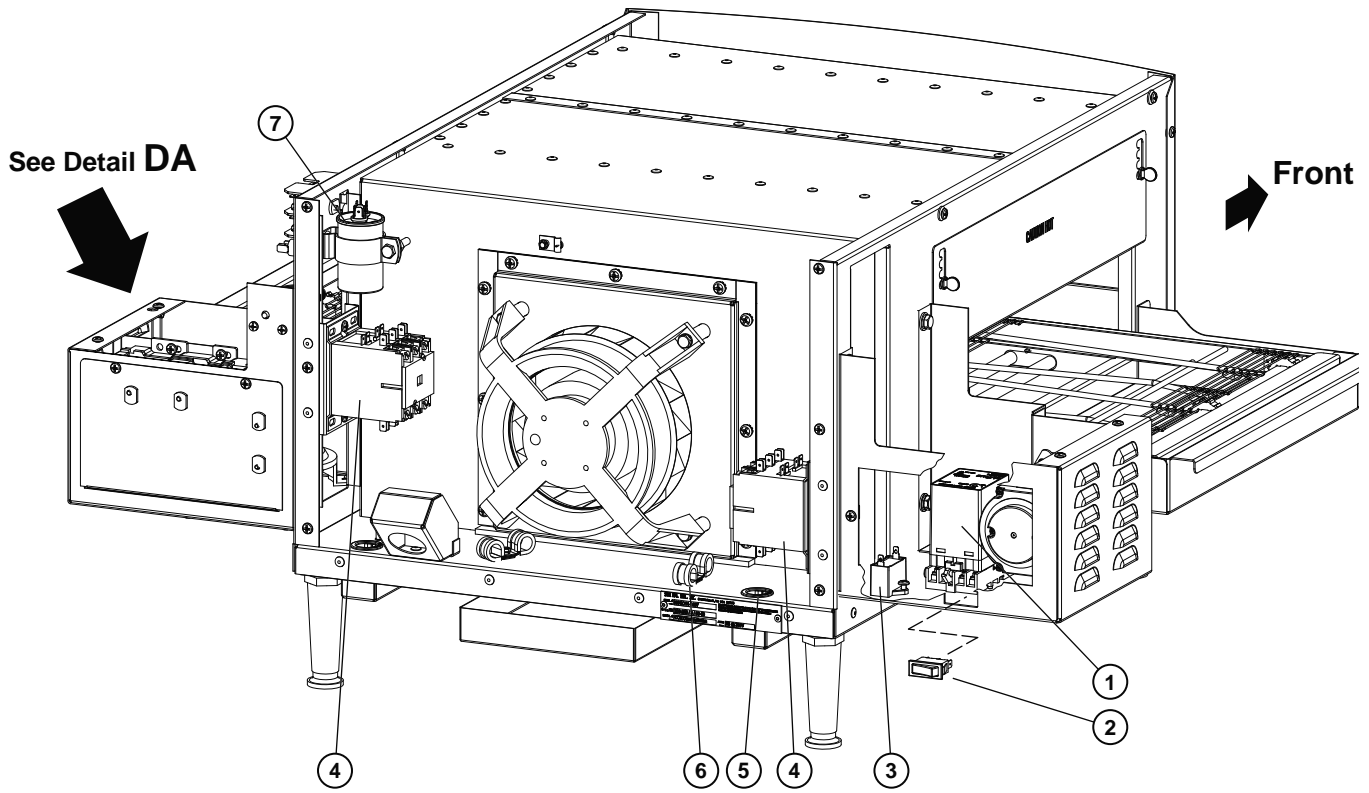

**Detail D**

**Detail DA**

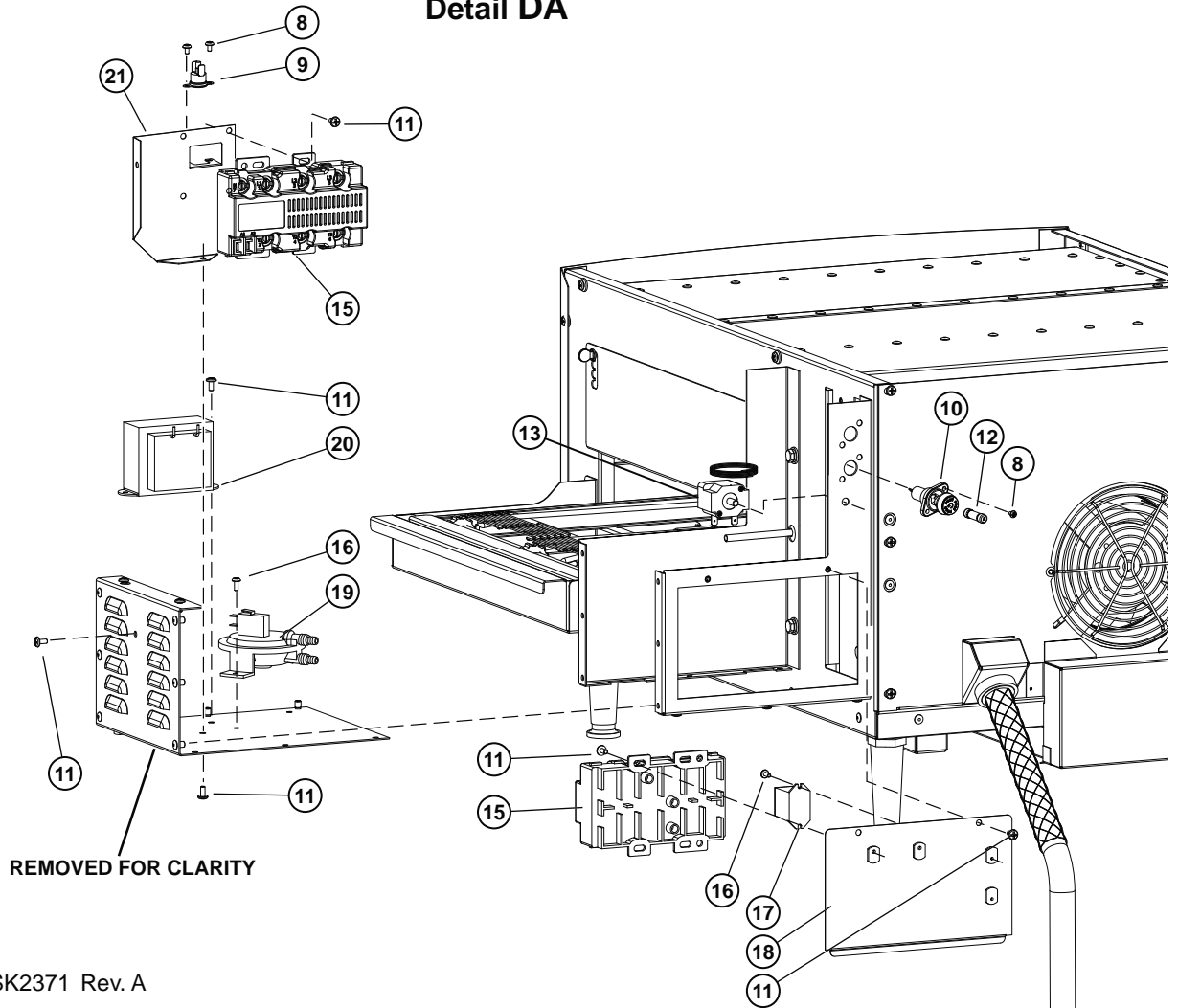

REMOVED FOR CLARITY

# PARTS LIST

August 19, 2011, Rev. B

TURBO-MAX CONVEYOR OVEN DETAIL D & DA				
Fig No	Part No	Qty	Description	Application
1	2E-Z8628	1	SPEED CONTROL-GEAR MOTOR	
2	2E-Z10526	1	SWITCH - SPDT	
3	2E-Z8629-1	1	GEARMOTOR, RUN CAPACITOR (SPARE, INCLUDED WITH NEW GEAR MOTOR)	
4	2E-Z11662	2	CONTACTOR, 3PH	
5	2K-Y5093	4	BUSHING-SNAP #SB-1000-12, 1" DIA	HSCO16, HSCO16P
	2K-Z6183		BUSHING 1.125" DIA	
6	2C-Z11577	4	WIRE CLAMP, CUSHIONED	
7	2E-Z5711	1	6 MF CAPACITOR (FAN MOTOR) (SPARE, INCLUDED WITH NEW FAN/MOTOR)	
8	2C-200067	10	SCREW, 6-32 X 1/4 PHIL TR	
9	2T-Z5176	1	THERMOSTAT, 140F UM1854	
10	2E-30901-08	2	FUSE HLDR FOR SC FUSE	
11	2C-200014	36	SCREW 8-32X3/8 THP SS	
12	2E-Z5680	2	FUSE, 5A - CLASS G	
13	2T-Z11707	1	HIGH TEMP LIMIT	
14	2C-200261	4	NUT WELD 3/8-16 SS	
14	2C-Z11707-1	1	NUT HIGH LIMIT	
15	2E-Z11514	2	POWER RELAY, HYBRID 3PH	
17	2E-Z10563	1	RELAY, DPDT - 24VAC	
18	B6-Z10577	1	ACCESS DOOR, RIGHT REAR	
19	2E-Z5683	1	SWITCH, DIFF. PRESS.	
20	2E-Z9090	1	TRANSFORMER W/BREAKER	
21	B6-Z11575	1	POWER RELAY BRACKET	

2M-Z11612 HSCO TURBO-MAX ELECTRIC SPEED CONV OVEN

