

TURBO-MAX™ TURBO-MAX™ TURBO-MAX™

TURBO-MAX™

ELECTRIC SPEED CONVEYOR OVEN

MODEL
HSCO14 & HSCO16

Installation and Operation Instructions

2M-Z11612 Rev.B 4/9/2012

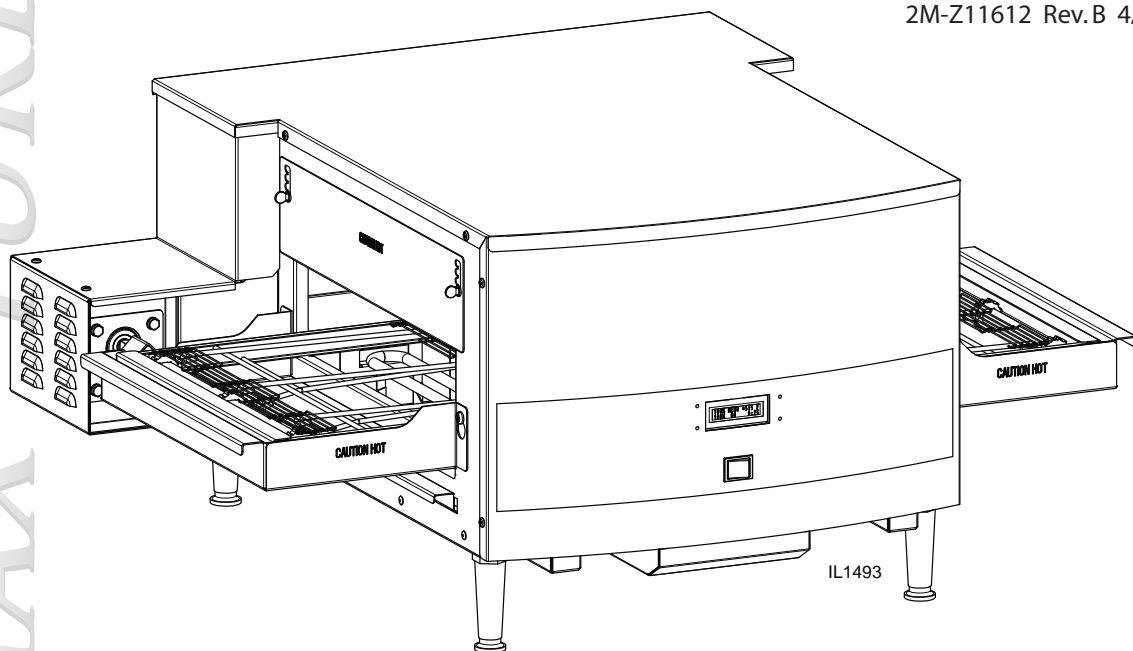

HSCO14



SAFETY SYMBOL



These symbols are intended to alert the user to the presence of important operating and maintenance instructions in the manual accompanying the appliance.

RETAIN THIS MANUAL FOR FUTURE REFERENCE NOTICE

Using any part other than genuine Star factory supplied parts relieves the manufacturer of all liability.

Star reserves the right to change specifications and product design without notice. Such revisions do not entitle the buyer to corresponding changes, improvements, additions or replacements for previously purchased equipment.

Due to periodic changes in designs, methods, procedures, policies and regulations, the specifications contained in this sheet are subject to change without notice. While Star International Holdings Inc., Company exercises good faith efforts to provide information that is accurate, we are not responsible for errors or omissions in information provided or conclusions reached as a result of using the specifications. By using the information provided, the user assumes all risks in connection with such use.

MAINTENANCE AND REPAIRS

Contact your local authorized service agent for service or required maintenance.

Please record the model number, serial number, voltage and purchase date in the area below and have it ready when you call to ensure a faster service.

Model No. _____

Serial No. _____

Voltage _____

Purchase Date _____

Authorized Service Agent Listing

Reference the listing provided with the unit

OR

for an updated listing go to:

Website: www.star-mfg.com
E-mail Service@star-mfg.com

Service Help Desk

Business Hours: 8:00 am to 4:30 p.m. Central Standard Time

Telephone: (314) 678-6303

Fax: (314) 781-2714

E-mail Parts@star-mfg.com
Service@star-mfg.com
Warranty@star-mfg.com

Website: www.star-mfg.com

Mailing Address: Star International Holdings Inc., Company
10 Sunnen Drive
St. Louis, MO 63143
U.S.A

FOR SERVICE IN EUROPE CONTACT:

Middleby Worldwide, Europe

Telephone: +34-94-454-2815

E-mail: mwwueurope@middleby.com



PROBLEMS, QUESTIONS or CONCERNS

Before you proceed consult you authorized service agent directory
or
Call the Technical Service & Parts Department at 314-678-6303.

TABLE OF CONTENTS

Specifications	4
Oven Components.	5
General Information	6
Electrical Installation.	6
Purchaser's Responsibility	6
Installation	7
Location	8
Uncrating & Assembly Instructions	8 - 9
Ventilation & Clearance	10
Electrical Connection	10
Operating & Programming	
Manager Lock Modes	12
Operation	12
Menu Only.	13
Menu Programming	13
Energy Saving Programming	13
Bake Time Versus Temperature	13
Conveyor Speed.	13
Time of Delivery	13
Cleaning Instructions	
Daily	14
Monthly	14
Annually	14
Nozzle Plate Assemblies	15
Conveyor Belt Tension	16
Conveyor Belt Link Removal	16
Warranty	17
Wiring Diagram	18
Exploded View & Parts List	
Main Body Assembly	20 - 21
Details A, B & C	22 - 23
Details D & DA.	24 - 25

NOTICE **Service on this or any other Holman appliance must be performed by qualified personnel only. Consult your Authorized Service Agent Directory. You can call our tech service line at 314-678-6303 or visit our website www.star-mfg.com for the service agent nearest you.**

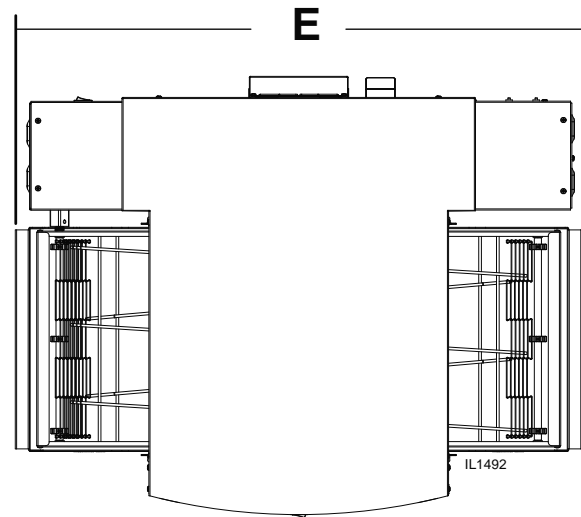
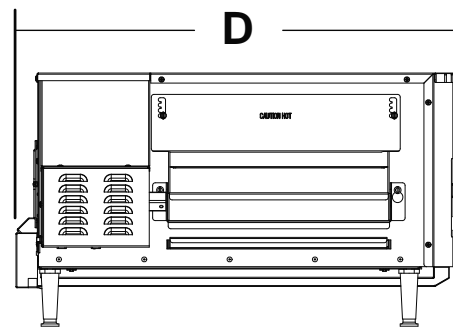
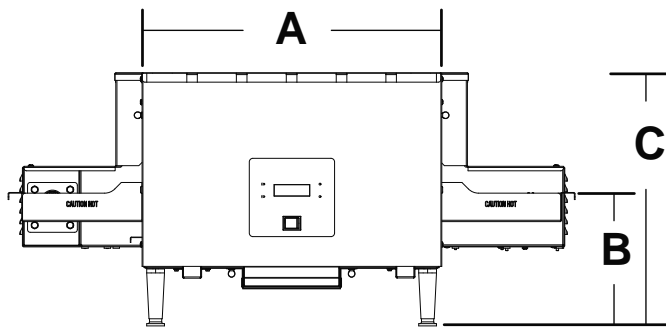

	HSCO14	HSCO16
A	20.8" (52.8 cm)	22.8" (57.9 cm)
B	9.4" (23.9 cm)	
C	17.8" (45.2 cm)	
D	30.7" (78 cm)	32.7" (83.1 cm)
E	39.8" (101.1 cm)	41.8" (106.2 cm)

SPECIFICATIONS								
Model	Electrical					Cord	Weight	
	Voltage	Hz	Watts	Amp	Phase		Installed	Shipping
HSCO14	208/240V	50/60Hz	15,900	34/38	3Ph	NEMA 15-50	154lbs / 70kg	259lbs / 117.7kg
HSCO16	208/240V						188lbs / 85.5kg	293lbs / 133.2 kg
HSCO16P	208/240V							
HSCO16P	230V			20/22				
HSCO16Q								

Recommended Minimum Clearances	
Rear of Oven to Wall	0" (0 cm)
Conveyor Extensions to Wall	6" (15.2 cm)

OVEN COMPONENTS

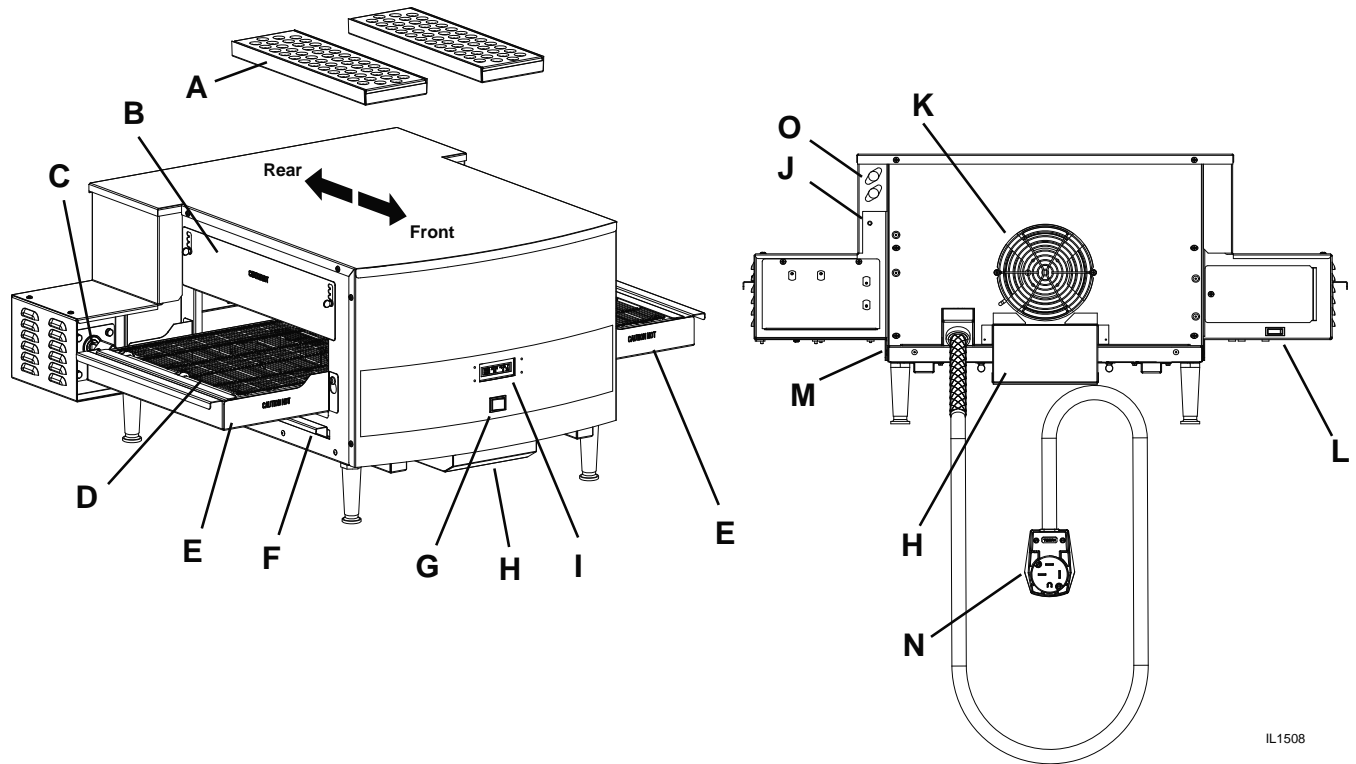

IL1508

OVEN COMPONENTS DESCRIPTION

- A: Fingers:** Projects streams of hot air onto the product.
- B: Heat Shutter:** Can be adjusted to various settings, depending on product being placed in the oven, to prevent heat loss.
- C: Drive Cog / Drive Collar:** This connects the drive motor to the conveyor assembly. You can disengage the conveyor by simply by pulling back on the drive collar. This makes for easy removal of the conveyor assembly.
- D: Conveyor Assembly:** Moves the product through the oven, & is easily removed for cleaning
- E: Crumb Tray:** Catches crumbs and other material that drops through the conveyor belt. Located at each end of the conveyor assembly.
- F: Cooking Chamber Crumb Tray:** Catches crumbs and other material that drops through the conveyor belt. Located at inside the cooking chamber, under the lower heating elements.
- G: Power Switch:** Turns the unit on & off.
- H: Cooling Air Duckwork:** Keeps the front control panel from overheating, the lower duct is held in by thumb screws, **DO NOT** operate without ductwork in place.
- I: Control Panel:** Easy to read Display for easy notification of ovens current operation, and buttons for making quick modifications. Located in front of the oven away from the areas which may cause burns.
- J: Hi-Limit Reset:** Monitors inside cooking temperature and will only trip when temperature reaches above 690°F.
- K: Air Intake:** Located in the back of the oven. **DO NOT BLOCK** this area, and wipe it clean on a regular basis.
- L: Conveyor Direction:** This switch changes the direction of the conveyor belt.
- M: Nameplate:** Has specific information regarding this units electrical & gas requirements as well as the units serial number which is needed for any service that will be required. This number should be written in the inside cover of this manual and kept for future needs
- N: Electrical Input:** Electrical Supply connection must meet all national and local electrical code requirements.
- O: Fuse:** Easily replaceable fuses, can be serviced easily without tools.

GENERAL INFORMATION

This equipment is designed and sold for commercial use only by personnel trained and experienced in its operation and is not sold for consumer use in and around the home nor for use directly by the general public in food service locations.

First and foremost, each crate should be examined before signing the Bill of Lading to report any visible damage by the trucker in transit and to account for the proper number of crates. If there is apparent damage, arrangements should be made to file a claim against the carrier. Interstate Commerce Regulations require that the claim must be initiated by the consignee. Proper and secure storage facilities should be arranged for the oven(s) if necessary to protect it from outdoor or damp conditions at all times before installation.

-IMPORTANT-

When you have all the crates unloaded, open the crates and remove all plastic covers. Inspect at once for concealed damage. If anything appears to be damaged, contact the appropriate persons immediately to file a damage claim. After completing this inspection, finish unpacking the oven. **Be sure to remove all paper protection and packing material from the unit prior to heating.**



CAUTION

FOR YOUR SAFETY DO NOT STORE OR USE GASOLINE OR OTHER FLAMMABLE VAPORS AND LIQUIDS IN THE VICINITY OF THIS OR ANY OTHER APPLIANCE.

INSTALLATION

The ovens are equipped for the voltage indicated on the nameplate mounted on the right side of the body under the control box. They will operate on alternating current (AC) only. A cord is provided with a NEMA 6-50 plug. A matching receptacle with 50A supply must be provided.



WARNING

WARNING

DO NOT CONNECT TO DIRECT CURRENT (DC).

The installation of the electric oven should conform to the:

NATIONAL ELECTRIC CODE AND ALL LOCAL ELECTRIC CODES AND ORDINANCES AND THE LOCAL ELECTRIC COMPANY RULES AND REGULATIONS.

PURCHASER'S RESPONSIBILITY

It is the responsibility of the purchaser:

1. To see that the electric services for the oven are installed on site in accordance with the manufacturer's specifications.
2. To unload, uncrate, and install the oven in its proper location and in accordance with this installation operation manual.
3. To see that electric services are connected properly by a qualified installer of your choice. All such connections must be in accordance with applicable code requirements.
4. To arrange for inspection and operation check-out by an authorized service technician.

IMPORTANT SAFETY INFORMATION

Do not attempt to operate the oven until connection of utility service has been fully inspected by an authorized service technician or a Star Service Representative. This service is required by Star in order to assist the purchaser in proper start-up of the oven on site. Please note the specific details on the Warranty and make certain that service connections are made to proper utility services.

The warranty shall not apply if the oven is started up and operated prior to the utilities and oven being inspected and check-out made by an authorized service technician or a Star Service Representative.



CAUTION

CAUTION

IMPROPER INSTALLATION, ADJUSTMENT, ALTERATION, SERVICE, OR MAINTENANCE CAN CAUSE PROPERTY DAMAGE, INJURY, OR DEATH. READ ALL INSTRUCTIONS THOROUGHLY BEFORE INSTALLING OR SERVICING THIS EQUIPMENT.



CAUTION

CAUTION

Minimum clearances must be maintained from all walls and combustible materials. Minimum clearances for this unit should be 0 inches from the rear (rear bumpers provided must be in place) and 6 inches from both sides. Keep the oven free and clear of all combustible material.



CAUTION

CAUTION

Do not obstruct the ventilation holes in the control panels as these provide cooling air for the controls.



WARNING

WARNING

The oven is to be operated only on the type of electricity shown on the specification plate.

INSTALLATION INFORMATION

THE INSTALLATION INSTRUCTIONS CONTAINED HEREIN ARE FOR THE USE OF QUALIFIED INSTALLATION AND SERVICE PERSONNEL ONLY. INSTALLATION OR SERVICE BY OTHER THAN QUALIFIED PERSONNEL MAY RESULT IN DAMAGE TO THE OVEN AND/OR INJURY TO THE OPERATOR.

Qualified installation personnel are individuals, a firm, a corporation, or a company which either in person or through a representative are engaged in and responsible for:

1. The installation of electrical wiring from the electric meter, main control box, or service outlet to the electric appliance.

Qualified installation personnel must be experienced in such work, familiar with all precautions required, and have complied with all requirements of state or local authorities having jurisdiction.

LOCATION

The well-planned and proper placement of your oven will result in long-term operator convenience and satisfactory performance.

It is essential that an adequate air supply to the oven be maintained to provide a sufficient flow of ventilation air. Follow these guidelines:

1. Place the oven in an area that is free of drafts.
2. Keep the oven area free and clear of all combustibles such as paper, cardboard, flammable liquids, and solvents.
3. Do not place the oven on a curb base or seal to a wall. This will restrict the flow of air and prevent proper ventilation to the blower motors. This condition must be corrected to prevent permanent damage to the oven.
4. On all models, tripping of the blower motor's thermal overload device indicates an excessive ambient temperature at the back of the oven. This condition must be corrected to avoid permanent damage to the oven.

OVEN UNCRATING & ASSEMBLY INSTRUCTIONS

This Turbo-Max Oven comes completely assembled and ready to use. These instructions will step you through, removing the unit from the skid and safely installing the legs, so not to damage the unit or the installer.

1. Using lift equipment, move oven as close to final position as possible.
2. Inspect the oven for any damage which may have been caused by freight transit or carrier. If any, see general information section.
3. Remove any packaging from around the unit or inside the cooking chamber.
4. Disengage the Drive Collar on the Conveyor to the Drive Cog on the drive motor.

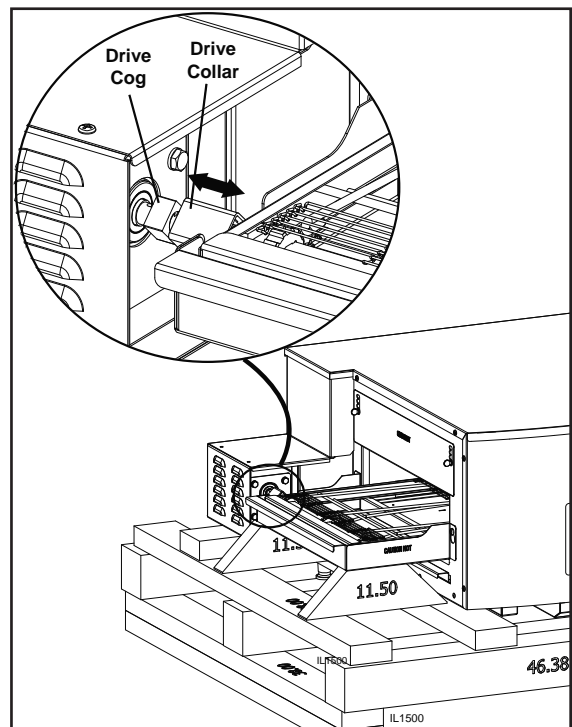

5. Lift and remove Conveyor from the unit and set aside.

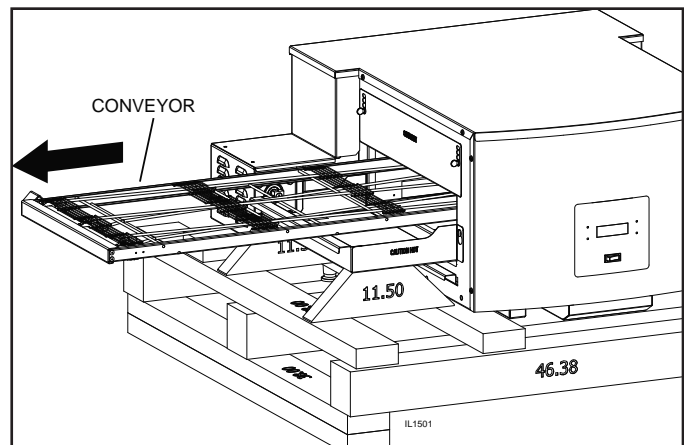

6. Remove the Crumb Trays and set aside.
7. Reach into the cooking area and remove the two Nozzle Plate Assy. Doing this will prevent them from being damaged while completing the unpacking.

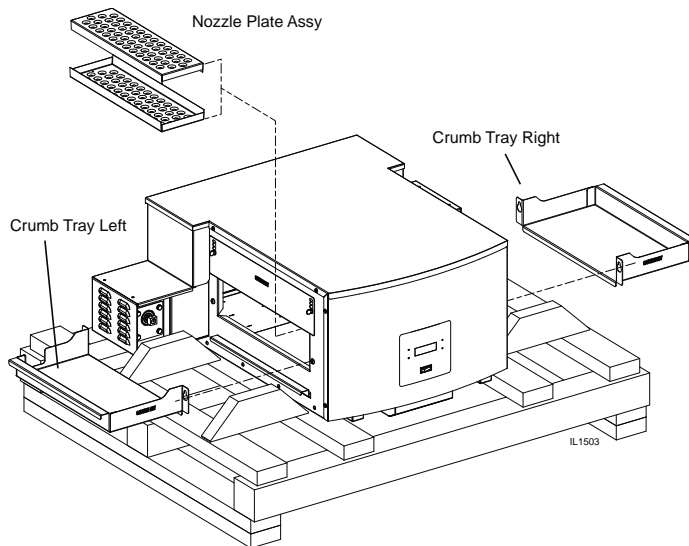

8. Unbolt the unit from the skid by removing the shipping restraints shown here.
9. The unit weights 110lbs, so with assistance, lift unit off the skid and place it on its back using a couple 2 x 4's.

NOTE: SETTING UNIT DIRECTLY ON IT BACK, WITHOUT EXTRA SUPPORT WILL DAMAGE THE COOLING AIR INLET AND THIS DAMAGE IS NOT COVERED BY WARRANTY.

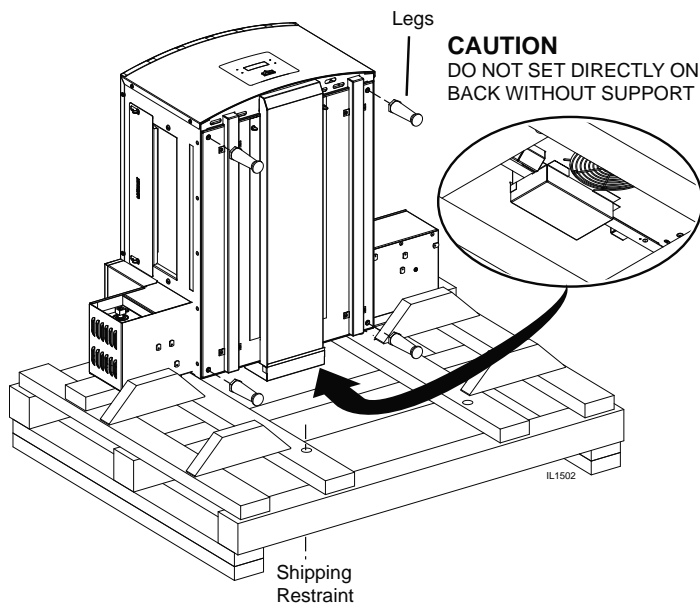

10. Using the legs provided, screw them into the holes shown here.

11. Set unit back on all four legs and place it into position.
12. Reinstall the nozzle and collumnating plates previously removed.
13. Re-install the crumb trays and conveyor belt assembly.
14. Engage the conveyor belts drive collar and the drive motors drive cog.
15. Assembly is complete.

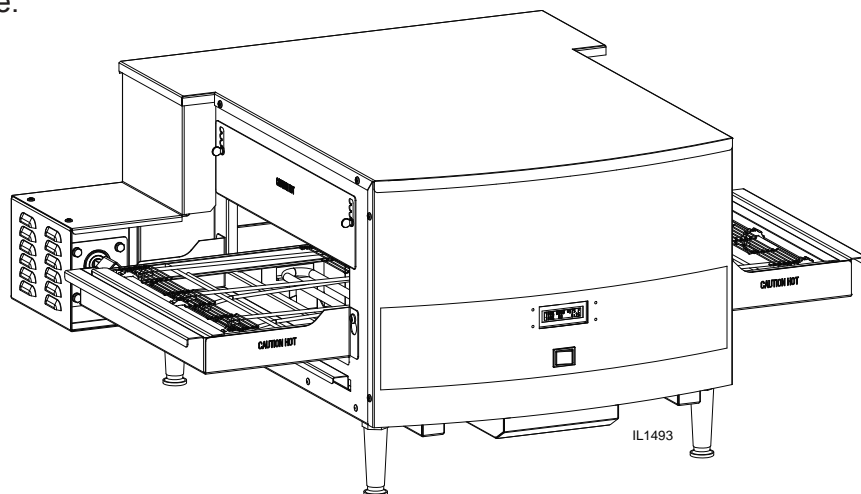

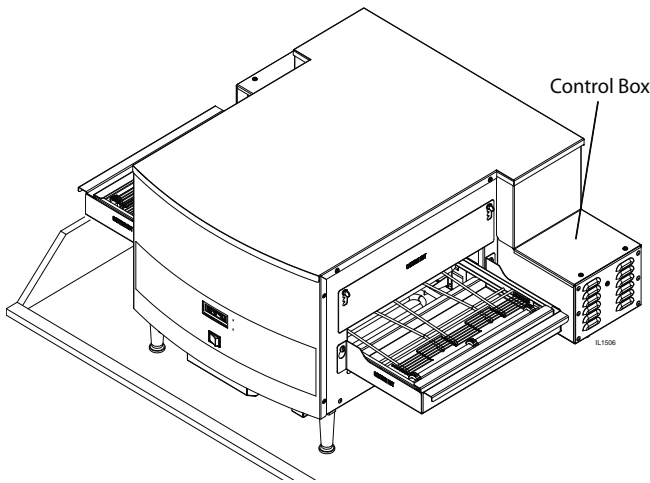

This unit must be installed on a sturdy counter or stand using the feet provided for cleaning clearance. As a minimum, 24" of clearance on the discharge end of the oven should be allowed for removal of the conveyor assembly if the oven is not on a mobile cart. Also allow room for a service technician to access the control box and the fan motor cover over the rear of the oven if the oven is not movable.



CAUTION

Any surface the oven is mounted on should have a raised area around the perimeter to prevent the oven from accidentally sliding off the edge. Serious injury or death could occur if the oven falls on a person.



CAUTION

Any cart that the oven is mounted on must be deep and wide enough to provide a stable platform. A cart with a narrow stance could allow the oven to tip over, causing property damage or serious harm to people.

VENTILATION

Local codes prevail. These are the "authority having jurisdiction" as stated by the National Fire Protection Association, Inc. in NFPA 96-Latest Edition. For further ventilation information see below.

A ventilation hood may be required to remove heat and cooking odors. The hood and HVAC installation must meet local codes to gain approval by the authority having jurisdiction. Requirements may vary throughout the country depending on the location by city, county, and state. Obtain information from the authority having jurisdiction to determine the requirements for your installation. Obtain information and review copies of codes or documents that will be used to inspect and approve your installation. Your ventilation hood supplier and HVAC contractor should be contacted to provide guidance.



CAUTION

Prevent airflow through the cooking tunnel. Air must NOT be directed onto the oven's front or rear or to the sides of the cooking area. This can cause incomplete or uneven baking and increased energy consumption.

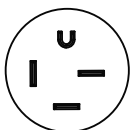

ELECTRICAL CONNECTION

Before making any electrical connections to this unit, check that the power supply is adequate for the voltage, amperage, and phase requirements stated on the rating plate. A wiring diagram is included herewith.

15-50

When installed, this appliance must be electrically grounded and its installation must comply with the National Electric Code, ANSI-NFPA 70, latest version, manufacturer's installation instructions, and applicable local municipal building codes. In Canada, all electrical connections are to be in accordance with CSA C22.1 - Canadian Electrical Code Part 1 and/or local codes.



WARNING

This appliance is equipped with a four-prong (grounding) plug for your protection against shock hazard and should be plugged directly into a properly grounded three-prong receptacle. Do not cut or remove the grounding prong from this plug.

2M-Z11612 HSCO TURBO-MAX ELECTRIC SPEED CONV OVEN

OPERATING & PROGRAMMING

SAFETY TIPS

For your safety, read before operating.

In the event of a power failure:

1. Turn all switches off.
2. **DO NOT** attempt to operate the oven until the power is restored.

General Safety Tips:

1. If the oven needs to be moved for any reason, the power must be disconnected from the unit before doing so.
2. **DO NOT** service this unit in any way unless the oven is unplugged.



Manager Lock Modes

There are three different levels to the managers lock, "OFF, MENU ONLY, ON". To determine what mode your unit is in, press both the "UP" & "DOWN" buttons and hold for 3 seconds. The current manager lock mode will be displayed. To change the mode, press the select button, then the enter button to activate, again to save. You then will be able to choose between: EXIT, which will return you back to the main menu, or NEXT, will take you into the menu programming.

OFF: There is no lock and operators can access/change/save any of the four control settings.

MENU ONLY: Operator may only toggle between 8 pre-programmed menu choices.

ON: No changes are allowed, the four control settings are locked and the oven will continue operating at these parameters.

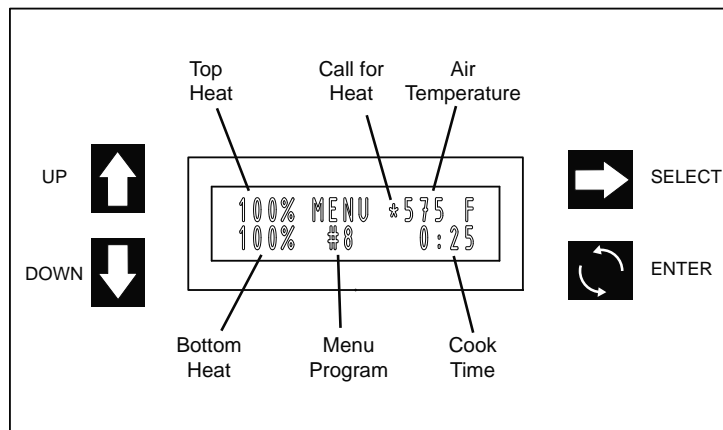

Above: Control Panel User Interface

IL1507

Operation

Push the power switch to "ON".

When the manager mode set to "OFF" you will be able to change any of the four settings, (top heat, bottom heat, air temperature & cook time) without affecting the saved programs. If you happen to set the exact same settings as that of one of your programs, that program will display to let you know it already exist.

1. Press the upper right button, once to see the current temperature, again to change the current settings.
2. It will display the current setting for the Top Heat, this can be adjusted by using press the two left buttons "UP & DOWN". This can be set between 0 – 100% in 5% increments.
3. Press "SELECT" to continue and do the same for the Bottom Heat.
4. Press "SELECT" to continue and move to "Air Temperature".
5. The current air temperature setting will be displayed; changes can be made by using the "UP & DOWN" buttons. Air temperature can be set between 200°F (93°C) to 650°F (343°C).
6. Press "SELECT" to continue to "Cook Time"
7. The current Cook Time or Conveyor Speed is displayed and can be adjusted by using the "UP & DOWN" buttons. This unit has a Time of Delivery range of 16 seconds to 12 minutes.
8. Enter again to activate.

Manager mode set to “Menu Only”

In this mode you will only be able to choose one of 8 pre-determined programs.

1. Press the upper right button, once the see the current temperature, again to view the #1 program.
2. Press "SELECT" to toggle between the eight programs.
3. Press "ENTER" to choose one, again to activate.

MENU PROGRAMMING

Here you will be able to enter each of the 8 programs and change there settings. This mode should only be done once the settings are tested and proven, and you want to create and save a new program, or re-program new setting in to one of your existing programs.

1. Press the two left buttons “UP & DOWN”.
2. "ENTER" to continue.
3. Press/Change to Next by pressing "SELECT", then "ENTER" to continue
4. If you're cooking in °F, then "ENTER" to continue, to change to °C, press "SELECT", then "ENTER" to continue.
5. Press/Change to Next by pressing "SELECT", then "ENTER" to continue
6. This takes you to each program, one setting at a time.
7. It will display program #1 setting for the Top Heat, this can be adjusted by pressing the two left buttons “UP or DOWN”. This can be set between 0 – 100% in 5% increments.
8. Press "SELECT" to continue and do the same for the Bottom Heat.
9. Press "SELECT" to continue to “Air Temperature”.
10. The current air temperature setting will be displayed; changes can be made by using the “UP or DOWN” buttons. Air temperature can be set between 200°F (93°C) to 650°F (343°C).
11. Press "SELECT" to continue to “Cook Time”
12. The programmed Cook Time or Conveyor Speed is displayed and can be adjusted by using the “UP & DOWN” buttons. This unit has a Time of Delivery range of 00:16 seconds to 12:00 minutes
13. Press "SELECT" to toggle between the four menu settings, pressing "ENTER" at any time will prompt a “SAVE”, press "SELECT" to toggle between “YES” and “NO”, "ENTER" to select
14. Change between “EXIT/MGR LOCK/NEXT MENU” by pressing "SELECT".
 - a. EXIT = Ends programming and takes you to normal operation mode
 - b. MGR LOCK = Takes you back to the Manager Lock Menu.
 - c. NEXT = Takes you through the next saved program.

ENERGY SAVING PROGRAMMING

You can use menu programming to manage your energy usage and lower your operating cost, without compromising you final product. During slow traffic times, switching to a lower top and bottom heat and a slower cook time, will save your energy cost. These menus can be saved and easily switched at any moment.

BAKE TIME VERSUS TEMPERATURE

1. Bake time is actually conveyor speed and is defined as the time the product is actually in the oven. This is measured by noting the time when the leading edge of the product enters the oven and the time the leading edge of the product leaves the oven. This is adjusted by using the conveyor speed controller.
2. Bake temperature is adjusted by changing the setpoint of the temperature controller to the desired bake temperature. When the oven reaches the desired temperature, the red dot in the lower right corner of the temperature display will turn off and on as the controller maintains the temperature.
3. When establishing a bake time and temperature for a given product, the general rule shall be as the bake time increases the bake temperature decreases and the reverse is also true; increase temperature, decrease time. However, there are limits to the above rule. Going to extremes will result in a burnt exterior and raw interior or it will result in a very light color but over-baked product.
4. Once a good bake has been established, the fine adjustments should be made by holding either the bake time or bake temperature constant, then varying the other.

CONVEYOR SPEED

Bake Time (Conveyor Speed) - As stated previously, bake time (conveyor speed) is defined as the amount of time elapsed between the time the leading edge of the product enters the oven and the leading edge of the product exits the oven. Bake time is controlled by adjusting the digital speed controller. The setting on the control panel indicates the actual bake time.

Bake time will be the same for any size product.

TIME OF DELIVERY

The time of delivery is the amount of elapsed time between the period when the leading edge of the product enters the oven and the trailing edge of the product is fully discharged and is ready to be delivered to the customer.

Time of delivery changes if the product size changes.

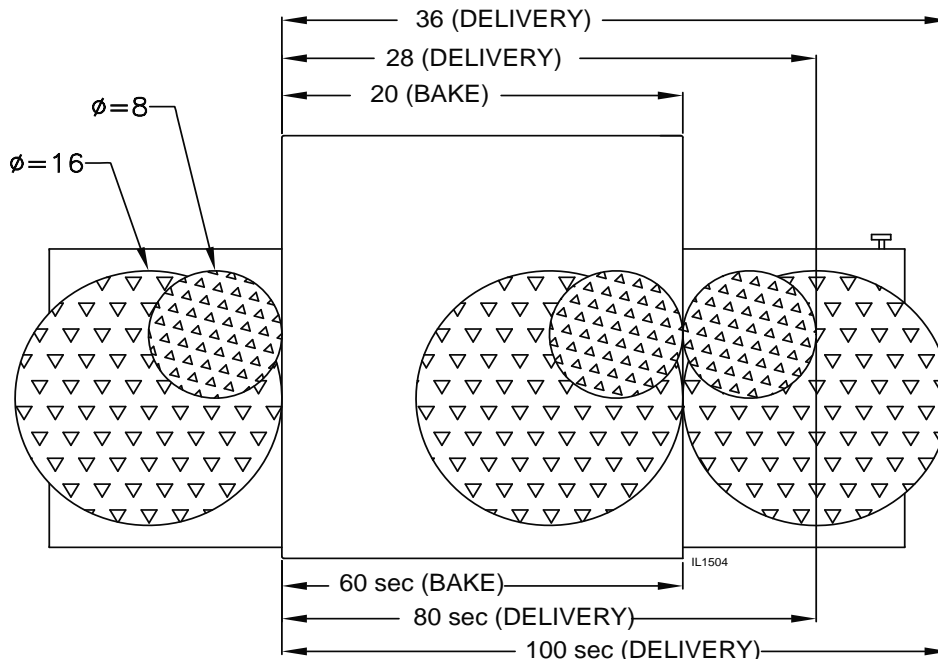

Tip: Train yourself not to pull the product out of the oven when the leading edge comes out. Always wait until the entire product has passed under the air nozzle holes - the product needs this time to fully bake.

BAKE vs. DELIVERY TIME

Time to Delivery changes with product
but **Bake Time** remains constant
at a steady conveyor speed.

CLEANING INSTRUCTIONS

Follow this recommended cleaning schedule for proper oven performance:



CAUTION

DISCONNECT THE POWER SUPPLY BEFORE SERVICING OR CLEANING THIS OVEN. SAFEGUARD THE POWER SO IT CANNOT BE ACCIDENTALLY RESTORED. FAILURE TO DO SO COULD RESULT IN DISMEMBERMENT, ELECTROCUTION, OR FATAL INJURY. THERE IS MORE THAN ONE POWER SUPPLY CONNECTION POINT WHEN OVENS ARE STACKED, SO MAKE SURE THAT ALL SWITCHES ARE IN THE OFF POSITION BEFORE CLEANING OR MAINTENANCE.

No electrical components should be subjected to moisture. It is therefore important that the oven is wiped down carefully. **NEVER** throw buckets of water over the oven or subject it to pressure washing from a hose or a pressure spray. If water or other liquid is spilled on the oven, make sure that none of it has entered the control box area before switching the oven ON. If in doubt, call your service company.



CAUTION

CAUTION

Adhere to the following warnings when cleaning or maintaining your conveyor oven:

1. The oven must be cool. Do not use power cleaning equipment, steel wool, or wire brushes on stainless steel surfaces.
2. Do not use a caustic or an alkaline base cleaner on the interior of the oven. This will ruin the aluminized finish of the oven interior.
3. When using cleaning solutions, be sure they meet local and national health standards.

DAILY

1. Clean the conveyor belt using a nylon brush. Allow any foreign material to drop into the crumb pans.
2. Empty and clean the crumb pans. Use a hot water and detergent mix. Rinse with clean water.

EVERY MONTH *(See Oven Components for location)*

1. Brush and clean the guard on the motor cooling fan.
2. Unplug the oven.
3. Remove the crumb pans.
4. Remove the conveyor assembly.
5. Remove the Nozzle Assy (outer nozzle plate & inner columnating plate).
6. Clean the oven interior with an appropriate oven cleaner.
7. Clean the conveyor assembly, crumb pans, and other removable components. Wash in a hot water, detergent mix and rinse with clean water. For difficult cleaning areas, use a heavy-duty de-greaser or oven cleaner.
8. Move the oven and clean under it. Be careful not to damage the oven's electrical cord or plug when moving.
9. Remove the cooling air duct if necessary.



CAUTION

DO NOT OPERATE UNIT WITHOUT THE COOLING AIR DUCT IN PLACE, DOING SO WILL CAUSE THE UNIT TO OVERHEAT AND CAUSE DAMAGE TO THE OVEN.

10. Reassemble the oven, being certain to include both nozzle assemblies (two parts to each assy) and the cooling air duct..

EVERY TWELVE MONTHS

A factory authorized service person should:

1. Open and clean the inside of the control box.
2. Check and tighten all electrical components.

If maintenance is required, contact your local service company, a factory representative, or Holman Manufacturing.

Removing Nozzle Plate Assemblies

1. Once cooled, **REMOVE** conveyor assembly, crumb trays & eyebrows.
2. Reaching into the cooking chamber, lift up on one edge of the nozzle plate assy, allowing it to be removed from the unit, *See Detail A*. Repeat for second assy.
3. Separate the assembly and wash in a hot water, detergent mix and rinse with clean water. For difficult cleaning areas, use a heavy-duty de-greaser or oven cleaner.

Reassemble Nozzle Assemblies

1. Reassemble nozzle assemblies and install in unit.
2. Nozzle assy sit on the rail located at the top of the cooking chamber.



CAUTION

CAUTION

NEVER OPERATE UNIT WITHOUT THE PROPER NOZZLE PLATE ASSEMBLIES PROPERLY INSTALLED.

3. Reinstall crumb trays, conveyor & eyebrows, and test unit for proper operation.

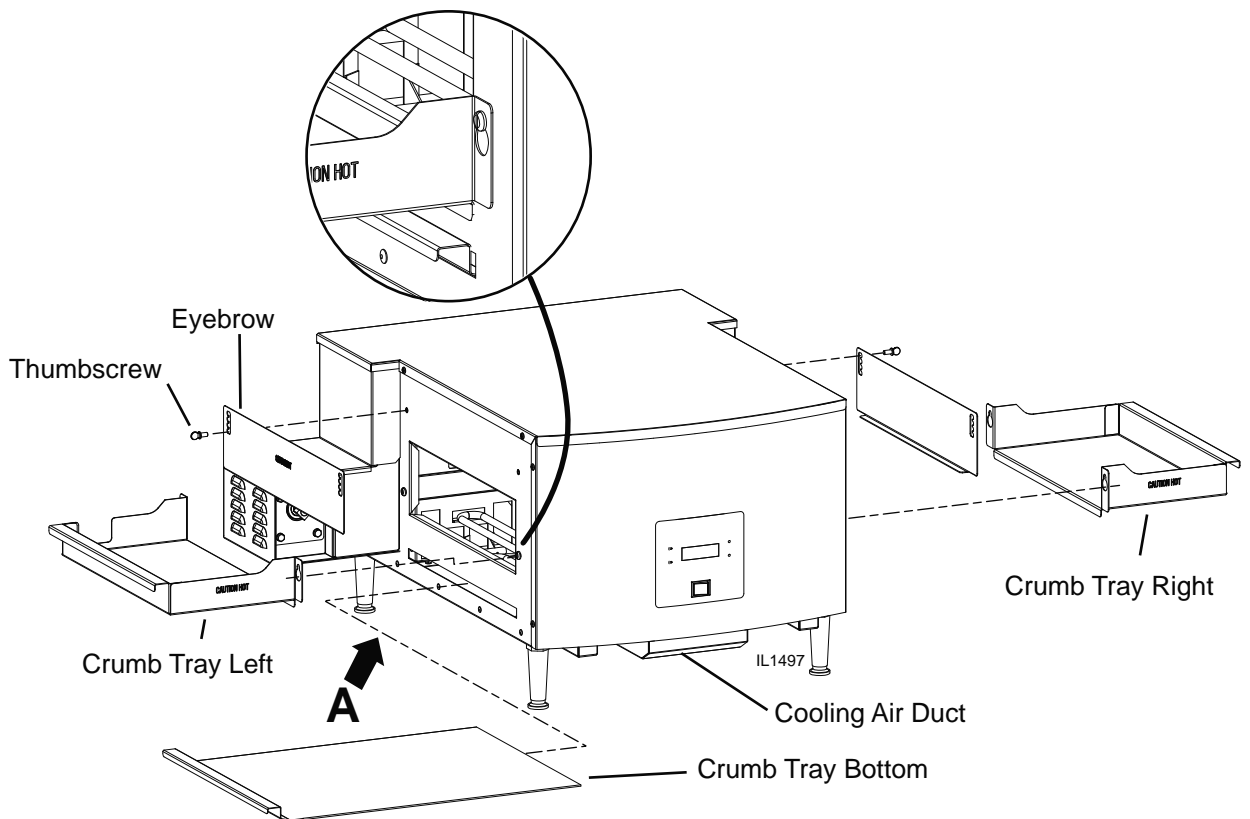

Above: Removable parts (conveyor not shown),
Right: Nozzle Plate Assy (qty 2) can be easily removed for cleaning, by simply lifting up on one edge and allowing it to fall out of place.

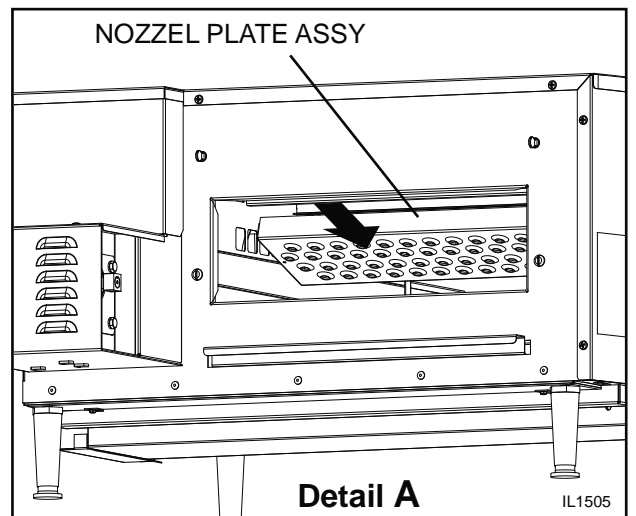

CONVEYOR BELT TENSION

The conveyor belt of the Turbo-Max Conveyor Oven does not have a tension adjustment. If the belt becomes too loose, a link will have to be removed to tighten. A belt that is too tight will also cause operational problems due to excessive drag. We suggest that you have a qualified service technician perform this adjustment.



CAUTION

Careful consideration should be exercised prior to removing a belt link because a belt that is too tight will impede the smooth operation of the conveyor.

CONVEYOR BELT LINK REMOVAL

An entire link can be removed with the conveyor assembly either in or out of the oven. This may be necessary as the belt stretches after continuous use. Following are the necessary steps for removing links:

1. Move the splice clips to either end of the oven for easy access.
2. Unhook the splice clips using long nose pliers.
3. Unhook the full link to be removed and slide it out. Do not discard the link removed as it may be used for making spare splice clips.
4. Reconnect the inside splice clips.
5. Reconnect the outside splice clips.
6. Replace all parts removed from the oven.
7. Straighten any bent wires to ensure smooth sprocket engagement.

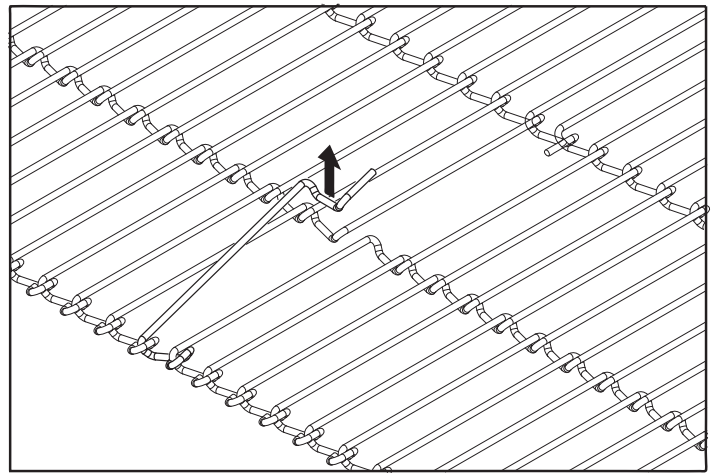

Remove the outside master links on the right and left sides of the conveyor belt. Remove the center splice clips next.

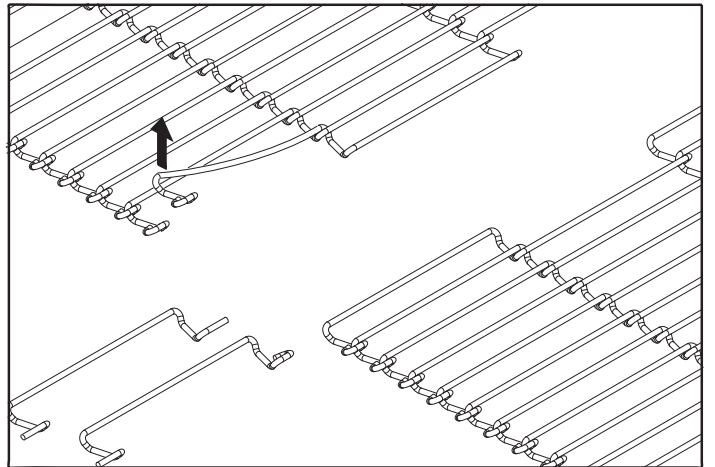

Unhook the end loop and pull up on the link section. Save this link as it may be used for making splice clips.

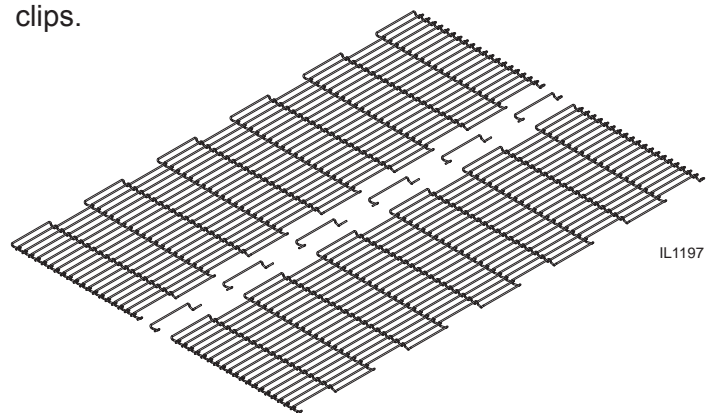
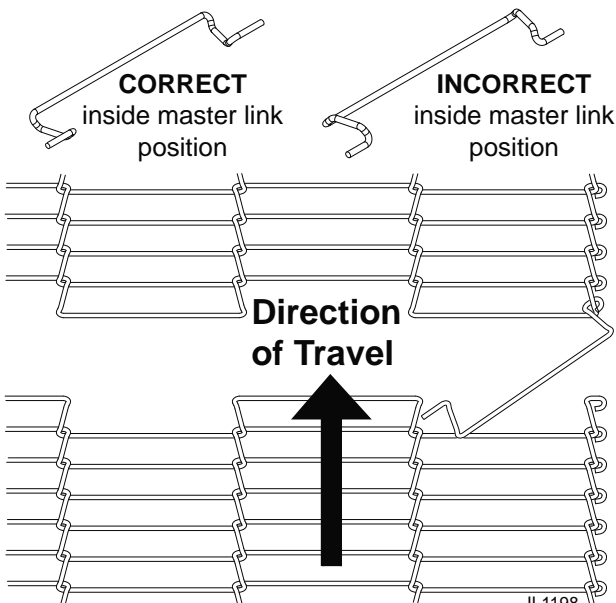

Check the orientation of the splice clips (the hooks should be up). The belt shown is the top section, ready for left-to-right travel.

THOROUGHLY INSPECT YOUR UNIT ON ARRIVAL

This unit has been tested for proper operation before leaving our plant to insure delivery of your unit in perfect condition. However, there are instances in which the unit may be damaged in transit. In the event you discover any type of damage to your product upon receipt, you must immediately contact the transportation company who delivered the item to you and initiate your claim with same. If this procedure is not followed, it may affect the warranty status of the unit.

LIMITED EQUIPMENT WARRANTY

All workmanship and material in Star products have a one (1) year limited warranty on parts & labor in the United States and Canada. Such warranty is limited to the original purchaser only and shall be effective from the date the equipment is placed in service. Star's obligation under this warranty is limited to the repair of defects without charge, by the factory authorized service agency or one of its sub-agencies. Models that are considered portable (*see below*) should be taken to the closest Star service agency, transportation prepaid.

- > Star will not assume any responsibility for loss of revenue.
- > On all shipments outside the United States and Canada, see International Warranty.
- * The warranty period for the Ultra-Max, Hot Plates, Griddles, Charbroilers is (3) years parts & labor.
- * The warranty period for the Star-Max, Charbroilers, Griddles, Hot Plates, Fryers & Finishing Oven is (2) years parts & labor.
- * The warranty period for the JetStar six (6) ounce & Super JetStar eight (8) ounce series popcorn machines is two (2) years.
- * The warranty period for the Chrome-Max Griddles is five (5) years on the griddle surface. See detailed warranty provided with unit.
- * The warranty period for Teflon/Dura-Tec coatings is one year under normal use and reasonable care. This warranty does not apply if damage occurs to Teflon/Dura-Tec coatings from improper cleaning, maintenance, use of metallic utensils, or abrasive cleaners, abrasive pads, product identifiers and point-of-sale attachments, or any other non-food object that comes in continuous contact with the roller coating. This warranty does not apply to the "non-stick" properties of such materials.
- > This warranty does not apply to "Special Products" but to regular catalog items only. Star's warranty on "Special Products" is six (6) months on parts and ninety (90) days on labor.
- > This warranty does not apply to any item that is disassembled or tampered with for any purpose other than repair by a Star Authorized Service Center or the Service Center's sub-agency.
- > This warranty does not apply if damage occurs from improper installation, misuse, wrong voltage, wrong gas or operated contrary to the Installation and Operating instructions.
- > This warranty is not valid on Conveyor Ovens *unless* a "start-up/check-out" has been performed by a Factory Authorized Technician.

PARTS WARRANTY

Parts that are sold to repair out of warranty equipment are warranted for ninety (90) days. The part only is warranted, the labor to replace the part is **NOT** warranted.

SERVICES NOT COVERED BY WARRANTY

1. Travel time and mileage rendered beyond the 50 mile radius limit
2. Mileage and travel time on portable equipment (*see below*)
3. Labor to replace such items that can be replaced easily during a daily cleaning routine, ie; removable kettles on fryers, knobs, grease drawers on griddles, etc.
4. Installation of equipment
5. Damages due to improper installation
6. Damages from abuse or misuse
7. Operated contrary to the Operating and Installation Instructions
8. Cleaning of equipment
9. Seasoning of griddle plates
10. Voltage conversions
11. Gas conversions
12. Pilot light adjustment
13. Miscellaneous adjustments
14. Thermostat calibration and by-pass adjustment
15. Resetting of circuit breakers or safety controls or reset buttons
16. Replacement of bulbs
17. Replacement of fuses
18. Repair of damage created during transit, delivery, & installation OR created by acts of God

PORTABLE EQUIPMENT

Star will not honor service bills that include travel time and mileage charges for servicing any products considered "Portable" including items listed below. These products should be taken to the Service Agency for repair:

- * The Model 510FD, 510FF Fryer.
- * The Model 526TOA Toaster Oven.
- * The Model J4R, 4 oz. Popcorn Machine.
- * The Model 518CMA & 526CMA Cheese Melter.
- * The Model 12MC & 15MC & 18MCP Hot Food Merchandisers.
- * The Model 12NCPW & 15NCPW Nacho Chip/Popcorn Warmer.
- * All Hot Dog Equipment **except Roller Grills & Drawer Bun Warmers.**
- * All Nacho Cheese Warmers **except Model 11WLA Series Nacho Cheese Warmer.**
- * All Condiment Dispensers **except the Model HPD & SPD Series Dispenser.**
- * All Specialty Food Warmers **except Model 130R, 11RW Series, and 11WSA Series.**
- * All QCS/RCS Series Toasters **except Model QCS3 & RCS3 Series.**
- * All Fast Steamer Models **except Direct Connect Series.**

ALL:

- * Pop-Up Toasters
- * Butter Dispensers
- * Pretzel Merchandisers
(Model 16PD-A Only)
- * Pastry Display Cabinets
- * Nacho Chip Merchandisers
- * Accessories of any kind
- * Sneeze Guards
- * Pizza Ovens
(Model PO12 Only)
- * Heat Lamps
- * Pumps-Manual

The foregoing warranty is in lieu of any and all other warranties expressed or implied and constitutes the entire warranty.

FOR ASSISTANCE

Should you need any assistance regarding the Operation or Maintenance of any Star equipment; write, phone, fax or email our Service Department. In all correspondence mention the Model number and the Serial number of your unit, and the voltage or type of gas you are using.

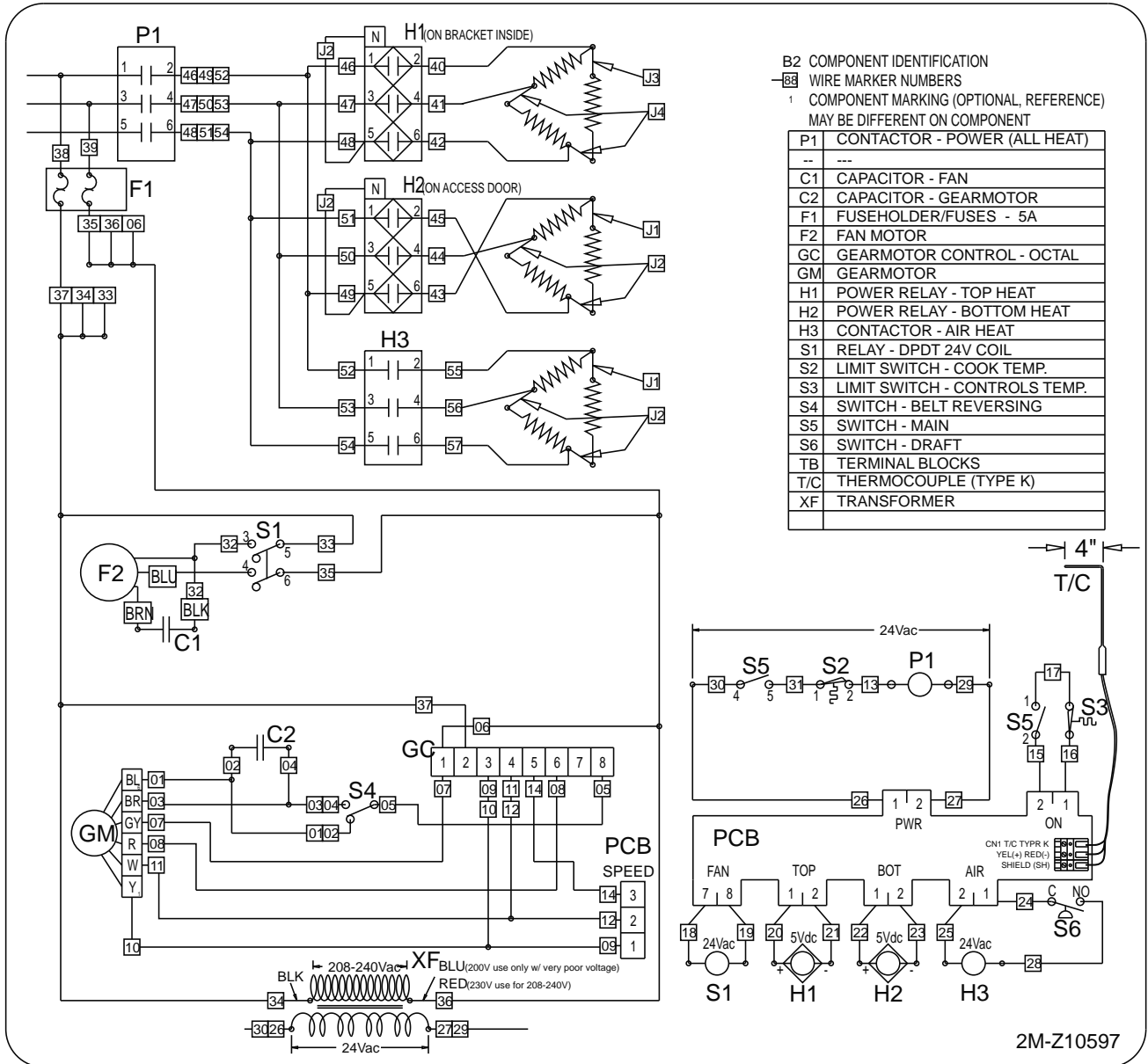

This wiring diagram is a reproduction of a label which was included with the oven.

MODELS:

HSCO14-240V, 50/60 Hz, 3PH, 34/38 Amp, 15,900 Watts
 HSCO16-240V, 50/60 Hz, 3PH, 34/38 Amp, 15,900 Watts
 HSCO16P-240V, 50/60 Hz, 3PH, 34/38 Amp, 15,900 Watts

THIS DRAWING CONTAINS INFORMATION CONFIDENTIAL TO STAR MFG. INT'L. INC.
 NO REPRODUCTION OR DISCLOSURE OF ITS CONTENTS IS PERMITTED.



SK2529 Rev -

8/18/2011

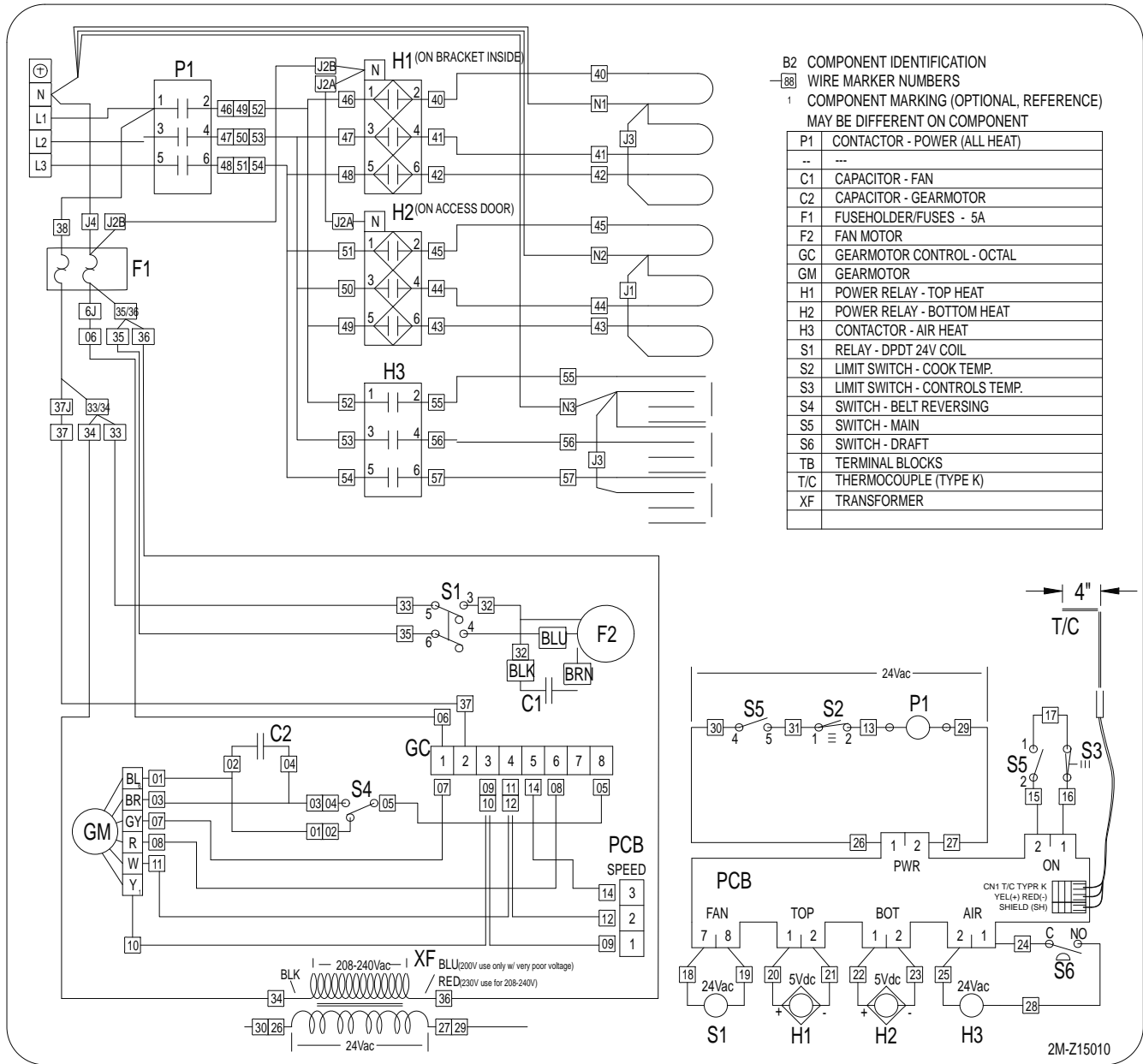

This wiring diagram is a reproduction of a label which was included with the oven.

MODEL:
HSCO16P-230V, 50/60 Hz, 3PH, 34/38 Amp, 15,900 Watts



THIS DRAWING CONTAINS INFORMATION CONFIDENTIAL TO STAR MFG. INT'L. INC.
NO REPRODUCTION OR DISCLOSURE OF ITS CONTENTS IS PERMITTED.

SK2530 Rev - 8/18/2011

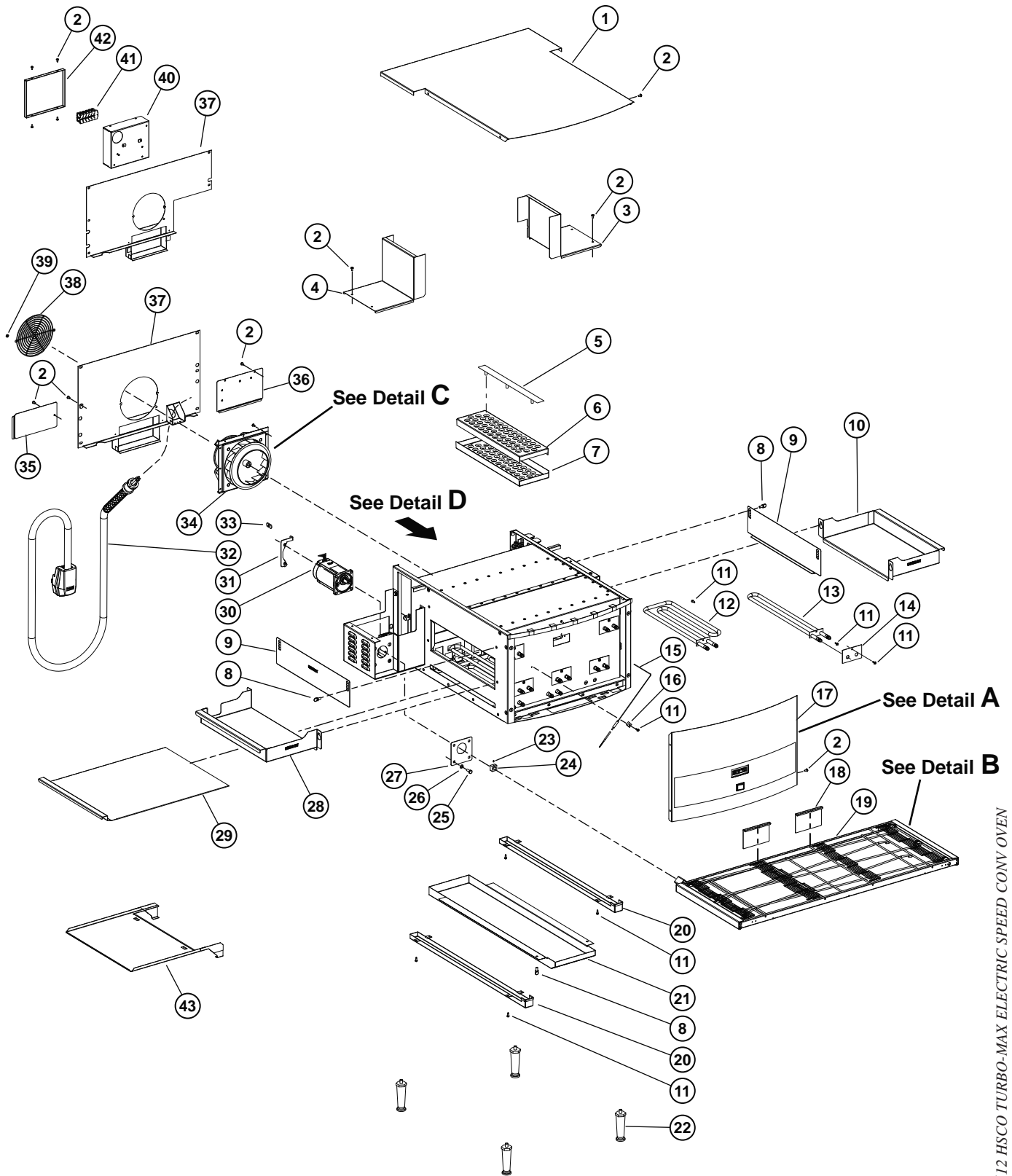

2M-Z11612 HSCO TURBO-MAX ELECTRIC SPEED CONVEY OVEN

Model: HSCO High Speed Conveyor Oven, Main Assy



SK2370 Rev. C 8/23/12

PARTS LIST

April 9, 2012, Rev. B

TURBO-MAX CONVEYOR OVEN, MAIN ASSEMBLY				
Fig No	Part No	Qty	Description	Application
1	B6-SC0001	1	COVER - SCO-1420	HSC014
	B6-SC0032		COVER - SCO 1624	HSC016
2	2C-200014	36	SCREW 8-32X3/8 THP SS	
3	B6-Z10550	1	CONTROL COVER, RIGHT	
4	B6-Z10548	1	CONTROL COVER, LEFT	
5	B6-Z13421	4	BLOCKOFF PLATE	HSC016P
6	B6-Z10566	2	COL. PLATE, SCO - FULL	HSC014
	B6-Z11793		COL. PLATE, 1624 - FULL	HSC016
7	B6-Z10565	2	NOZZLE, SCO - FULL	HSC014
	B6-Z11792		NOZZLE , 1624 - FULL	HSC016
8	2C-Z5182	6	SCREW 1/4-20X1/2 THUMB	HSC014
9	B6-Z11269	2	TUNNEL SHROUD (EYEBROW)	HSC014
	B6-Z11798			HSC016
10	B6-Z10574	1	CRUMB TRAY, RIGHT	HSC014
	B6-Z11794		CRUMB TRAY, RIGHT - 1624	HSC016
11	2C-Z6925	22	SCREW #8X1/2 HEXW B SS	
12	2N-Z10579	3	ELEMENT, METAL - AIR HEAT	HSC014
	2N-Z11760			HSC016
13	2N-Z11503	6	ELEMENT, METAL - TOASTING	HSC014
	2N-Z11761		ELEMENT, METAL - TOASTING	HSC016
14	B6-Z11570	6	ELEMENT COVER PLATE	
15	2J-Z5189	1	THERMOCOUPLE ASSEMBLY	
16	2C-Z3350	3	HALF CLAMP .188 D STL ZP	
17	B6-SC0009	1	FRONT PANEL ASSY - 1420	HSC014
	B6-SC0037		FRONT PANEL ASSY - 1624	HSC016
18	B6-Z13422	2	RETURN BLOCKOFF PLATE	HSC016P
19	B6-SC0014	1	CONVEYOR ASSEMBLY	HSC014
	B6-SC0036		CONVEYOR ASSEMBLY - 1624	HSC016
20	B6-Z11265	2	WIREWAY, BOTTOM - SCO	HSC014
	B6-Z11797		WIREWAY, BOTTOM - SCO	HSC016
21	B6-Z10582	1	COOLING DUCT	HSC014
	B6-Z11791		COOLING DUCT, SCO1624	HSC016
22	2A-Z0314	4	FOOT, 4 IN DIE CAST	
23	2C-Y5567	1	SET SCREW 10-24X.125	
24	2A-Z8633	1	DRIVE COG	
25	2C-Z5555	4	BOLT 1/4-20 X .75 HEX SS	
26	2C-Z5557	4	WASHER 1/4 SPLIT SS	
27	B5-Z8661	1	GEAR MOTOR COVER PLATE	
28	B6-Z10575	1	CRUMB TRAY, LEFT	HSC014
	B6-Z11795		CRUMB TRAY, LEFT - 1624	HSC016
29	B6-Z10511	1	CRUMB TRAY, BOTTOM	HSC014
	B6-Z11796		CRUMB TRAY, BOTTOM - 1624	HSC016
30	2U-Z10407	1	GEARMOTOR - 40:1 BROTHER - INCLUDES RUN CAPACITOR	
31	B6-Z10596	1	GEARMOTOR FASTENER BRACKET	
32	2E-Z10585	1	CORD ASSEMBLY #8 15-50	240V
33	2C-200262	2	NUT, WELD, 1/4 IN.	
34	B6-SC0003	1	FAN PLUG ASSEMBLY	
35	B6-Z10583	1	ACCESS DOOR, LEFT REAR	
36	B6-Z10577	1	ACCESS DOOR, RIGHT REAR	
37	B6-SC0024	1	REAR PANEL ASSEMBLY- 1420	HSC014
	B6-SC0031		REAR PANEL ASSEMBLY- 1624	HSC016
	B6-SC0041		REAR COVER ASY-HSC016 230V	HSC016-230V
38	2R-Z11567	1	GUARD, FAN - WIRE	
39	2C-Z2594	2	NUT 6-32 HEX W STL NP	
40	B6-Z15052	1	TERMINAL BOX ASSY	HSC016-230V
41	2E-200472	5	TERMINAL BLOCK LG 222	HSC016-230V
	2E-200473	1	TERMINAL BLOCK END LG 230	HSC016-230V
42	B6-Z15055	1	TERMINAL BLOCK COVER	HSC016-230V
43	B6-SC0043	1	DISCHARGE SANDWICH SHELF	HSC016Q-230V

2M-Z11612 HSCO TURBO-MAX ELECTRIC SPEED CONVEY OVEN

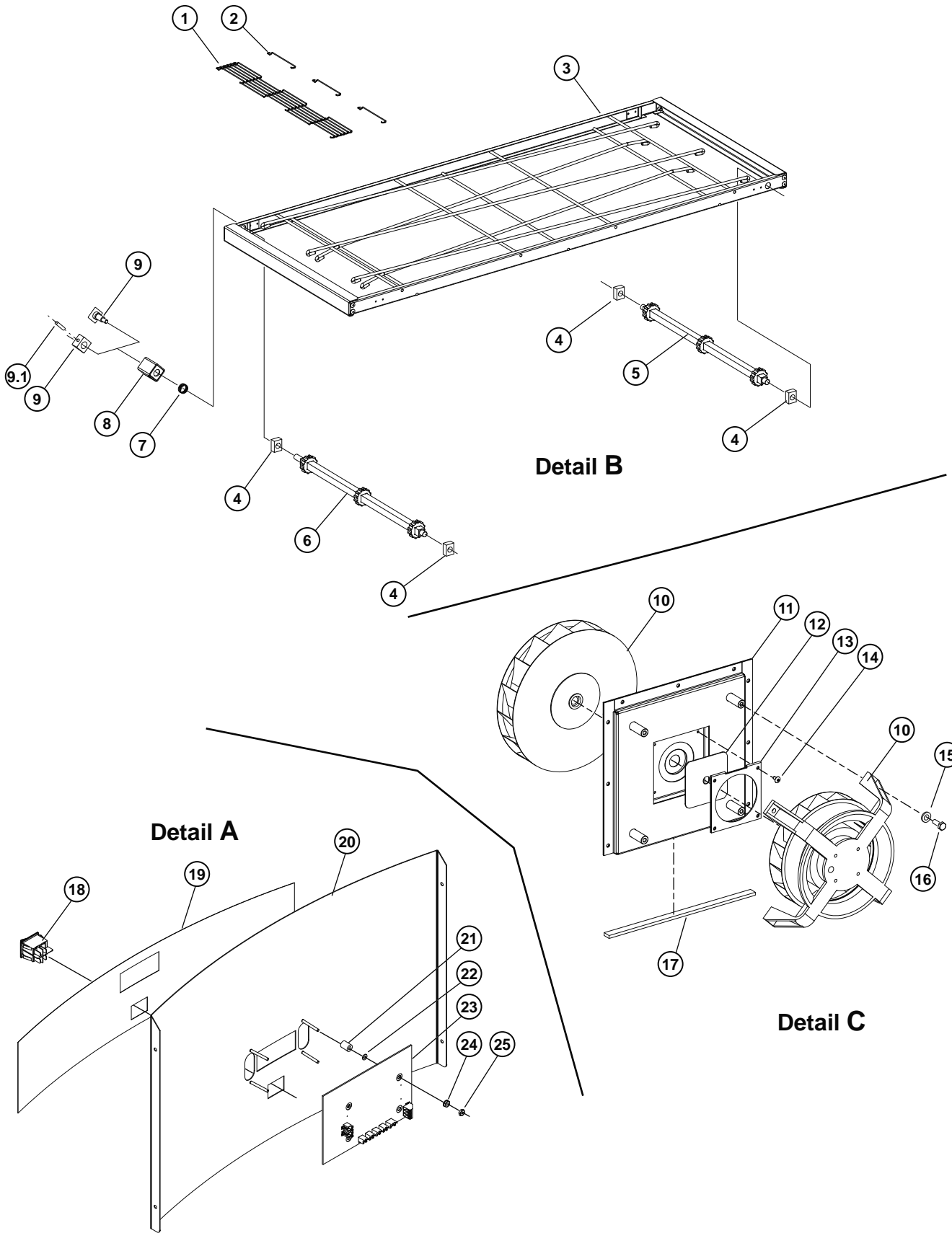

2M-Z11612 HSCO TURBO-MAX ELECTRIC SPEED CONY OVEN

PARTS LIST

August 19, 2011, Rev. B

TURBO-MAX CONVEYOR OVEN DETAILS A, B & C				
Fig No	Part No	Qty	Description	Application
1	2B-Z10516-2	1	CONVEYOR BELT SEGMENT 72"	HSC014
	2B-Z11833-2			HSC016
2	2B-Z10516-1	3	BELT CLIP, SINGLE SPACE	HSC014
	2B-Z11833-1	5		HSC016
3	B6-SC0006	1	CONVEYOR WELDMENT	HSC014
	B6-SC0035		CONVEYOR WELDMENT - 1624	HSC016
4	2P-Z5168	4	BEARING, OVEN CONVEYOR	
5	2A-SC0013	1	IDLER ASSEMBLY	HSC014
	2A-SC0034		IDLER ASSEMBLY - 1624	HSC016
6	2A-Z13691	1	DRIVESHAFT ASSEMBLY - HSC014	HSC014
	2A-Z13692		DRIVESHAFT ASSEMBLY - HSC016	HSC016
<i>NEEDS 2A-Z13646 & 2C-Z13647</i>				
7	2P-Z9051	1	SPRING-COUPLING	
8	B5-LC0013	1	COUPLING ASSY	
9	B6-SC0022	1	RETAINER DRIVE COG	
	2A-Z13646		DRIVEN COG, UNITS BUILT AFTER 7/2010	UNITS AFTER: COE3607100001 & COE4007100001
9.1	2C-Z13647	ROLL PIN 1/8 X 3/4, UNITS BUILT AFTER 7/2010		
10	2U-Z5710	1	HOT AIR BLOWER, 230V - COMES WITH 2E-Z7511 CAPACITOR	
11	B6-SC0002	1	FAN PLUG WELDMENT	
12	2I-Z10509	1	SEAL, AIR - FAN SHAFT	
13	B6-Z10510	1	AIR SEAL RETAINER	
14	2C-6349	4	SCREW #8X3/8 B THP STL NP	
15	2C-Z5557	4	WASHER 1/4 SPLIT SS	
16	2C-Z5555	4	BOLT 1/4-20 X .75 HEX SS	
17	1P-E1523	1	TAPE SILICONE TYPE S618	
18	2E-Z11661	1	SWITCH, DPST - BLACK	
19	2M-Z10597	1	LABEL, DIAGRAM - SCO	
20	B6-Z10532	1	FRONT PANEL - 1420	HSC014
	B6-Z11831		FRONT PANEL - SCO 1624	HSC016
21	2A-Z3429	4	SPACER-NYLON .175X.375X.5	
22	2C-Z11541	8	WASHER, FLAT - #6 NYLON	
23	PS-Z11960	1	CONTROLLER, SCO	
24	2C-Z2594	4	NUT 6-32 HEX W STL NP	
25	2C-2553	4	NUT 6-32 HEX STL NP	

2M-Z111612 HSCO TURBO-MAX ELECTRIC SPEED CONVEYOR



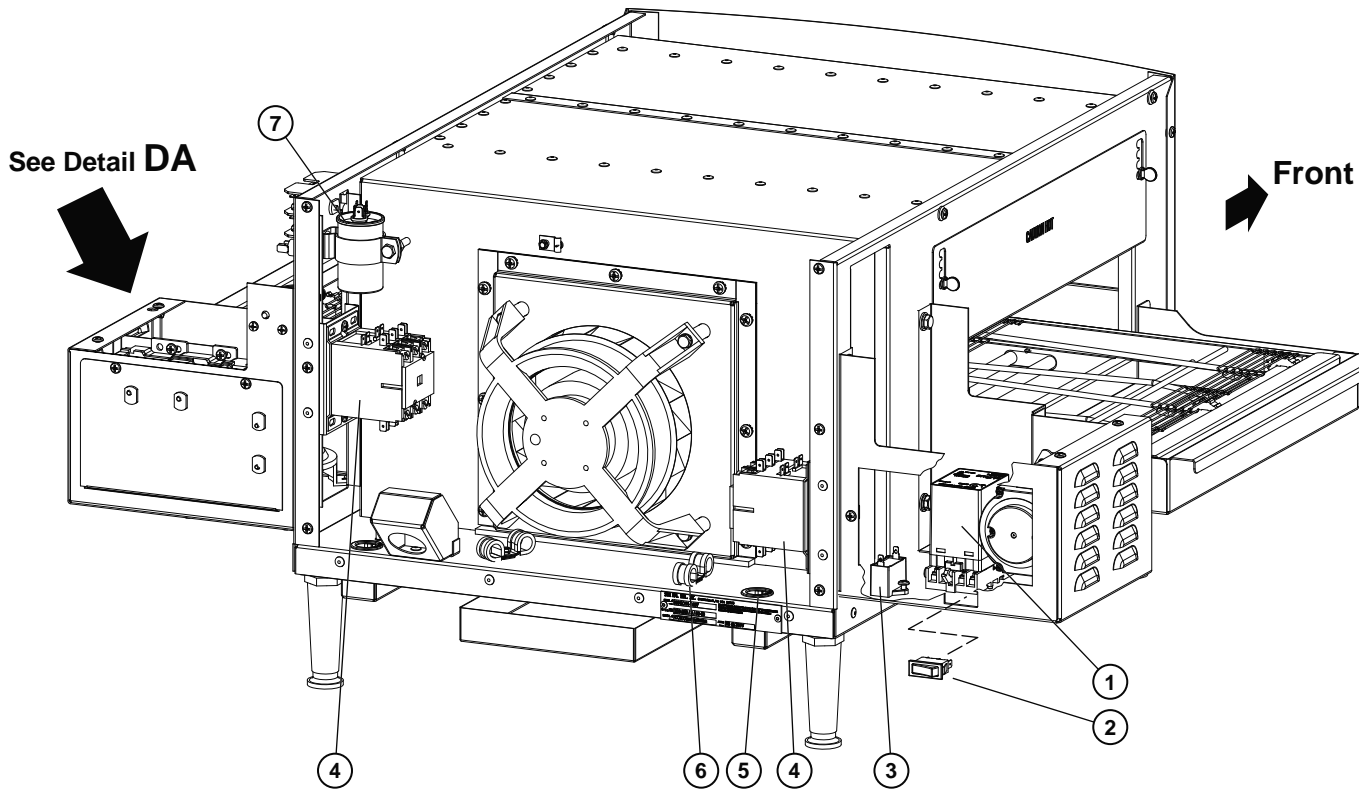

Detail D

Detail DA

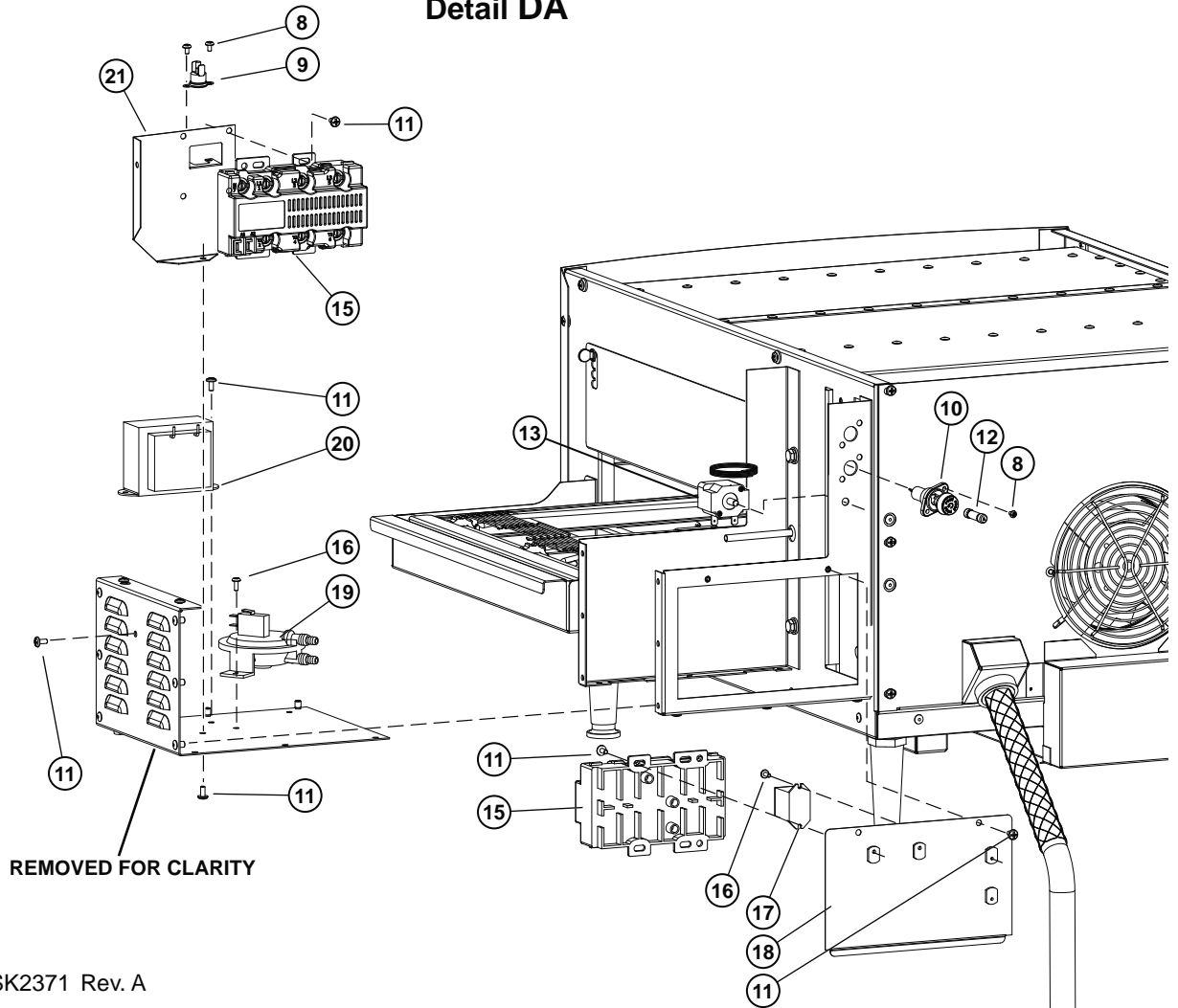

2M-Z11612 HSCO TURBO-MAX ELECTRIC SPEED CONVEY OVEN

PARTS LIST

August 19, 2011, Rev. B

TURBO-MAX CONVEYOR OVEN DETAIL D & DA				
Fig No	Part No	Qty	Description	Application
1	2E-Z8628	1	SPEED CONTROL-GEAR MOTOR	
2	2E-Z10526	1	SWITCH - SPDT	
3	2E-Z8629-1	1	GEARMOTOR, RUN CAPACITOR (SPARE, INCLUDED WITH NEW GEAR MOTOR)	
4	2E-Z11662	2	CONTACTOR, 3PH	
5	2K-Y5093	4	BUSHING-SNAP #SB-1000-12, 1" DIA	HSCO16, HSCO16P
	2K-Z6183		BUSHING 1.125" DIA	
6	2C-Z11577	4	WIRE CLAMP, CUSHIONED	
7	2E-Z5711	1	6 MF CAPACITOR (FAN MOTOR) (SPARE, INCLUDED WITH NEW FAN/MOTOR)	
8	2C-200067	10	SCREW, 6-32 X 1/4 PHIL TR	
9	2T-Z5176	1	THERMOSTAT, 140F UM1854	
10	2E-30901-08	2	FUSE HLDR FOR SC FUSE	
11	2C-200014	36	SCREW 8-32X3/8 THP SS	
12	2E-Z5680	2	FUSE, 5A - CLASS G	
13	2T-Z11707	1	HIGH TEMP LIMIT	
14	2C-200261	4	NUT WELD 3/8-16 SS	
14	2C-Z11707-1	1	NUT HIGH LIMIT	
15	2E-Z11514	2	POWER RELAY, HYBRID 3PH	
17	2E-Z10563	1	RELAY, DPDT - 24VAC	
18	B6-Z10577	1	ACCESS DOOR, RIGHT REAR	
19	2E-Z5683	1	SWITCH, DIFF. PRESS.	
20	2E-Z9090	1	TRANSFORMER W/BREAKER	
21	B6-Z11575	1	POWER RELAY BRACKET	

2M-Z11612 HSCO TURBO-MAX ELECTRIC SPEED CONV OVEN



STAR INTERNATIONAL HOLDINGS INC. COMPANY
Star - Holman - Lang - Wells - Bloomfield - Toastmaster
10 Sunnen Drive, St. Louis, MO 63143 U.S.A.
(314) 678-6303
www.star-mfg.com