

**PIZZAS OF EIGHT PIZZA SYSTEMS
OPERATOR'S MANUAL
MODEL PC18**

PARTS LIST CONT.

<u>PART #</u>	<u>QTY.</u>	<u>DESCRIPTION</u>
2A-200672	3	Shaft Collar
GF-100922	1	Drive Shaft PC18
GF-100923	1	Idler Shaft PC18
GB-112262	4	Shaft Bushings
2P-200643	1	25B11 x 5/16 Sprocket
2P-200654	1	25B24 x 3/8 Sprocket
SP-115360	3	Knob w/Cap & Skirt
2U-200590	1	Drive Motor 220V 50Hz Right to Left Belt Travel
2U-200504	1	Drive Motor 208-240V 60Hz Left to Right Belt Travel
2U-200509	1	Drive Motor 208-240V 60Hz Right to Left Belt Travel
GD-118060	1	Speed Control
2U-200561	1	Fan Motor 208-240V 60Hz
2R-200562	1	Fan Grill
2E-200566	1	Reset Switch
GF-160009	1	Conveyor Belt PC18
GF-100709	1	Belt Support System PC18
GG-101419	1	Right Side Tray PC18
GG-100419	1	Left Side Tray PC18
2E-200574	1	Fan Switch
GG-114250	9	Heater Tube, Metal, PC18, 208V
GG-114255	9	Heater Tube, Metal, PC18, 220V
2N-209207	9	Heater Tube, Metal, PC18, 240V
2J-200567	2	Heat Controls
2J-200568	2	Heat Probe
SP-115347	2	Stratford Control Assembly
GD-150023	1	Drive Chain

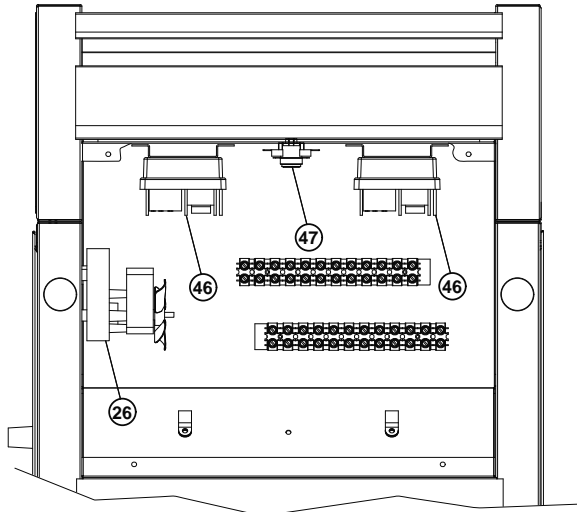

314 Stratford Control
Left to Right Conveyor

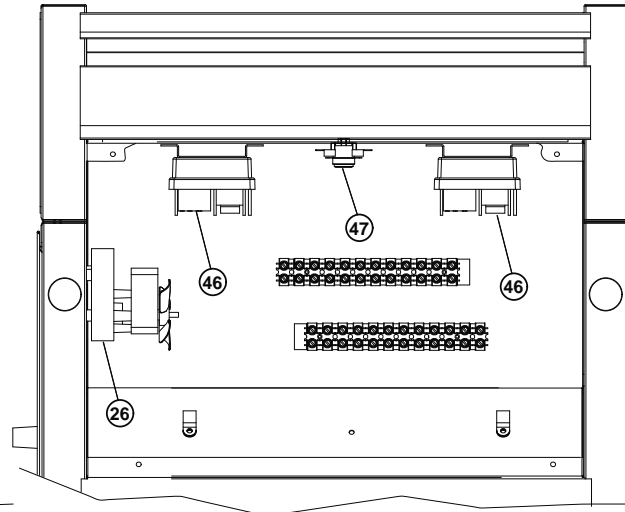

318 Stratford Control
Left to Right Conveyor

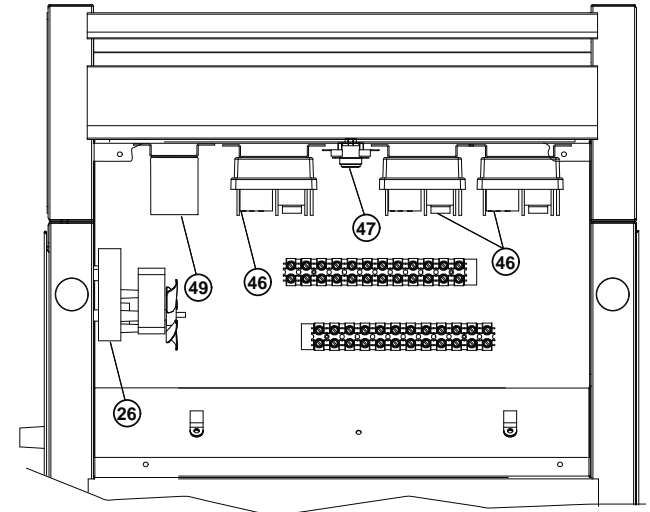

318 Stratford Control 3 Phase
Left to Right Conveyor

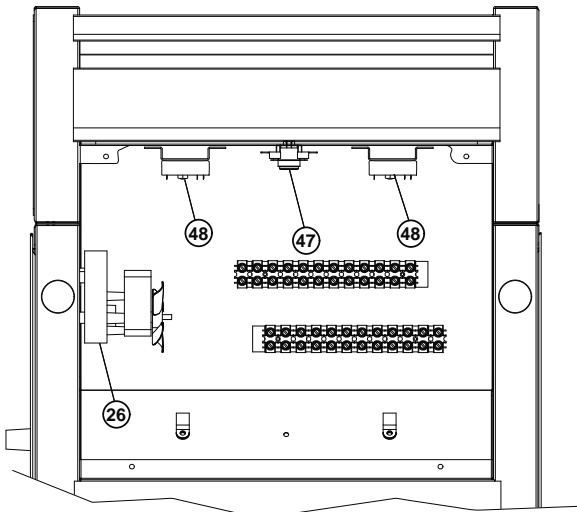

314 Phase Control
Left to Right Conveyor

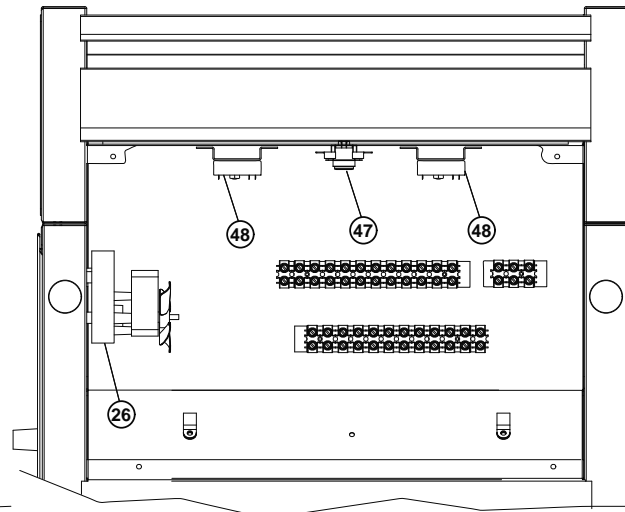

318 Phase Control
Left to Right Conveyor

MODEL: PROVEYOR CONTROL BOX CONFIGURATION



SK2146 Rev. - 9/12/05

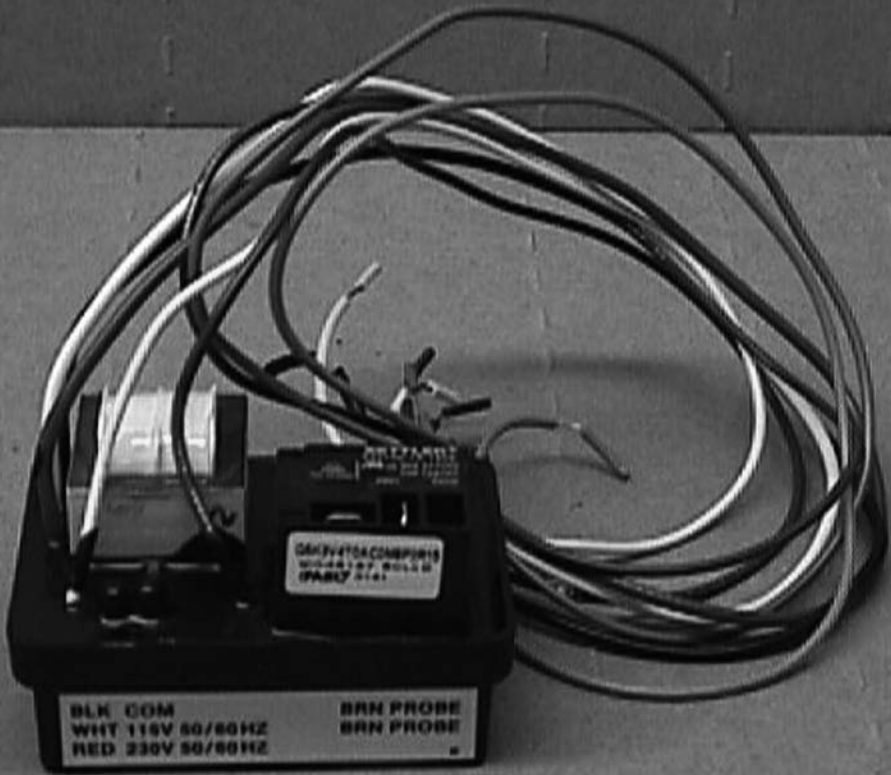

DC/3V-470K COMP 0.1%
W466187 BULK
PAB7 5141

BLK COM
WHT 115V 50/60HZ
RED 230V 50/60HZ

BRN PROBE
BRN PROBE

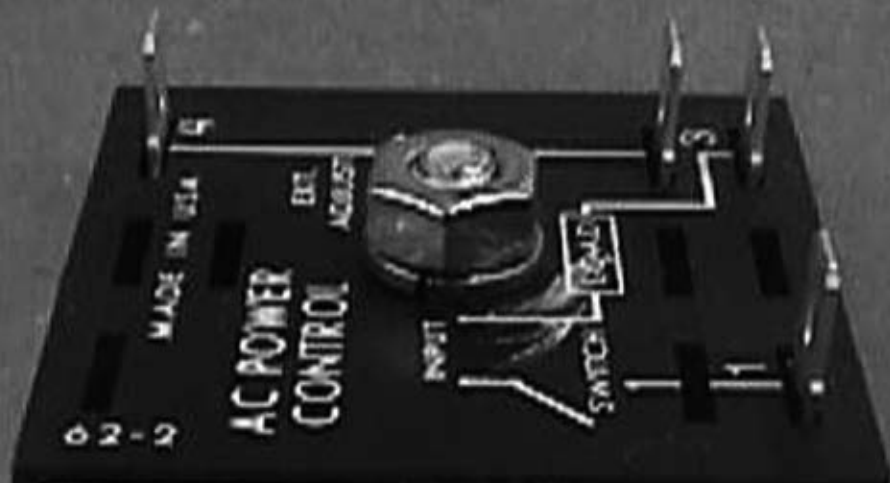

Solid State Control **entrelec**
Part No. PHS120A10
[2902]
120VAC Rating 10A Inrush 100A

02-2

MADE IN USA

AC POWER
CONTROL

EXT.
ADJUST

INPUT

SWITCH

LOAD

1

3

4

ABB Solid State Control **SSAC**
Part No. **PH5230A20** [5002]
230VAC Rating 20A Inrush 200A

