

PST28IE: PRO-MAX 2.0: 28" TWO SIDED GRILLS

Model: PST28IE, Top & Bottom Platen Assembly



SK2916, Rev. - 7/29/15

PARTS LIST

July 30, 2015, Rev. -

Model: PST28IE PLATEN ASSEMBLIES			
Fig No.	Part Number	Qty	Description
1	2V-Z20405	1	ARM, R/H, SPLIT TOP
	2V-Z20406	1	ARM, L/H, SPLIT TOP
2	2C-Z18300	2	SCR,SHLDR,SS,3/8 DIA.X1.0
3	2C-Z18751	4	SCR,SHLDR,SS,3/8 DIA.X.50
4	D9-GR0650	1	LINK AY., LEFT
5	2C-Z18752	4	LOCKNUT, ACORN,1/4-20,SS
6	2V-Z19346	1	PLATE,LIFTING,LEFT SIDE
7	2C-37498	4	BOLT HEX 3/8-16 X 1 SS
8	2C-Z19490	5	SCREW, 10-32 X 3/8 PH
9	2E-Z3768	2	LOCKNUT, CONDUIT, 1/2 IN.
10	2A-Z3827	1	PLATE,STAMPING - CONDUIT
11	2C-Z3780	2	RETAINER, CONDUIT
12	2C-Z3917	2	RIVET, POP, .188 (AD66BS)
13	2E-Z2898	1	CONDUIT ASSY. - PTFE
14	2C-Z5883	18	10-24 X 1/2 FZA SCREW
15	2C-Z19488	4	E-CLIP, INTERNAL
16	2V-Z19132	1	BEARING BLOCK LEFT ASSY
	2V-Z19131	1	BEARING BLOCK RIGHT ASSY
17	2C-Z2893	24	NUT 10-24 HEX STL ZP
18	D9-Z13099	4	BRACKET, INSLUATION
19	B9-04-WB-0046	2	CLAMP WIRE SUPPORT
20	2C-Y1451	4	RIVET 1/8 x .337 MORISON
21	D9-Z13012	2	WIRE MOUNT
22	D9-Z2075	2	TOP ELEMENT/INS. PLATE/14
23	D9-GR0563	2	ELMNT(MAKE FROM 2N-Z2391)
24	2C-1827	6	WASHER #10 EXT STL NP
25	2C-1512	10	SCREW 10-24X3/8 RHP STL
26	2C-8833	4	SCREW 8-18X1/2 HEX STL NP
27	2C-Z3350	4	HALF CLAMP .188 D STL ZP
28	2E-Z3278	2	RTD PROBE - 48" LONG WIRE
29	D9-Z14856	2	BRACKET, PROBE MOUNT
30	2C-08-07-0285	16	SCREW 10-24X3/4X3/8 TYPE
31	2F-Z1948	2	CASTING,SM.TOP,IRON-14
32	D9-Z15586	1	MACH.,14X28 IR.,SM.BTM
33	D9-GR0562	2	ELMNT(MAKE FROM 2N-Z2392)
34	D9-Z13338	2	ELEMENT & INSULATION PLT
35	2E-Z1470	2	SENSOR-RTD 2000 OHM
36	D9-Z12027	2	PROBE BRACKET - BOTTOM
37	D9-Z12885	4	INSULATION HOLD DOWN,

PST28IE: PRO-MAX 2.0: 28" TWO SIDED GRILLS

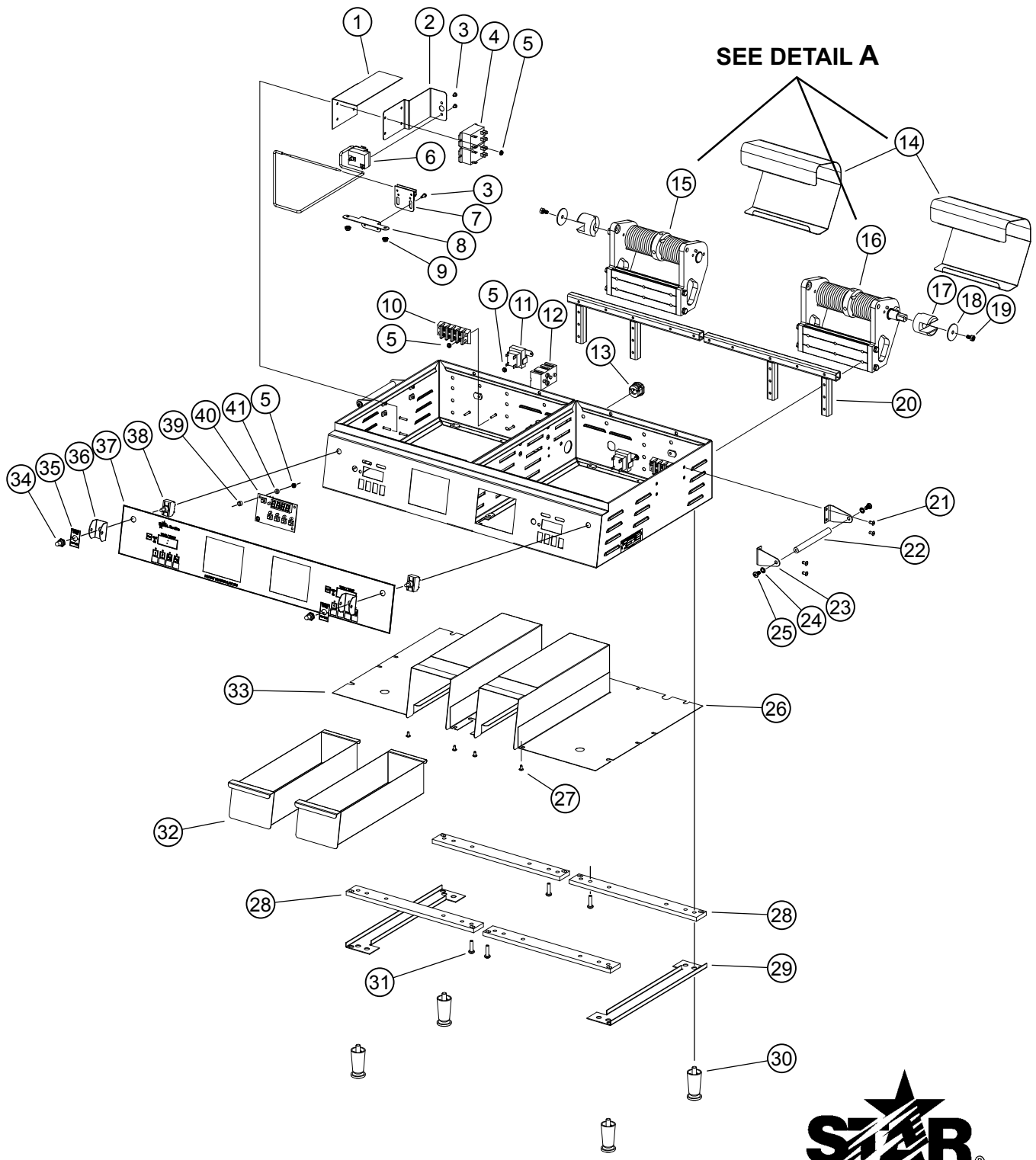

PST28IE: PRO-MAX 2.0: 28" TWO SIDED GRILLS

Model: PST28IE, Main Assembly



SK2917, Rev. - 7/29/15

PARTS LIST

July 30, 2015, Rev. -

Model: PST28IE PLATEN ASSEMBLIES			
Fig No.	Part Number	Qty	Description
1	D9-Z20267	1	INTERNAL BAFFLE, RLY L/H
	D9-Z20270	1	INTERNAL BAFFLE, RLY R/H
2	D9-Z17481	2	BRACKET,HIGH LIMIT
3	2C-8833	11	SCREW 8-18X1/2 HEX STL NP
4	2E-Z3335	4	RELAY DBL POLE-SNGL THROW
5	2C-Z2594	24	NUT 6-32 HEX W STL NP
6	2T-Z17489	2	THERMOSTAT,LIMITING,460F
7	D9-GR0632	2	ASSEMBLY, PROBE CLAMP
8	D9-Z17491	2	BRACKET, MOUNTING
9	2C-Z2893	4	NUT 10-24 HEX STL ZP
10	2E-Z2894	2	TERMINAL BLOCK (304)
11	2E-05-07-0350	2	TRANSFORMER 230V/10V 6VA
12	2E-Z8482	1	TERMINAL BLOCK
13	2K-3485	1	BUSHING HEYCO #SR-9
14	D9-Z20627	2	HINGE COVER
15	D9-GR0755	1	RIGHT HINGE ASSY.
16	D9-GR0754	1	LEFT HINGE ASSY
17	2V-Z19345	2	COLLAR AND STOP SPLIT TOP
18	2C-Z20628	1	FENDER WASHER
19	DD-49396	2	OBS - BOLT 1/4-20 X 1/2
20	2V-Z20410	2	REAR STIFFENER
21	2C-Y4275	8	RIVET 3/16X.300 POP AL SM
22	2V-Z3072	2	HANDLE-SIDE
23	D9-Z3071	4	BRACKET - HANDLE
24	2C-08-07-0262	12	WASHER, SS 1/4 INT-LOCK
25	2C-1522	4	SCREW 1/4-20X.5 STL R.H.
26	D9-GR0738	1	BASE ASSEMBLY, L/H
27	2C-6349	6	SCREW #8X3/8 B THP STL NP
28	2V-Z3027	4	CROSS SUPPORT
29	D9-Z17202	2	SUPPORT, LEGS
30	2R-200716	4	LEG, 2.5 IN METAL
31	2C-Z2992	8	BOLT 1/4-20X1 PHP STL NP
32	D9-GR0615	2	GREASE DRAWER ASSY
33	D9-GR0736	1	BASE ASSEMBLY
34	2I-05-07-0013	2	BOOT SWITCH
35	2M-Z18461	2	LABEL, POWER, ON AND OFF
36	Z1-70-07-0343	2	SWITCH GUARD
37	2M-Z18618	1	OVERLAY 28"
38	2E-Z3808	2	SWITCH(EATON)-30A@120V,
39	2K-Z1971	8	SPACER .257X.75X.25 NYLON
40	D9-GR0753	1	CNTL PROGRAM
41	2K-08-07-0004	8	SPACER ROUND NYLON
NI	2E-Z2922	1	CORD STO 10/3NEMA L6-30P

PST28IE: PRO-MAX 2.0: 28" TWO SIDED GRILLS

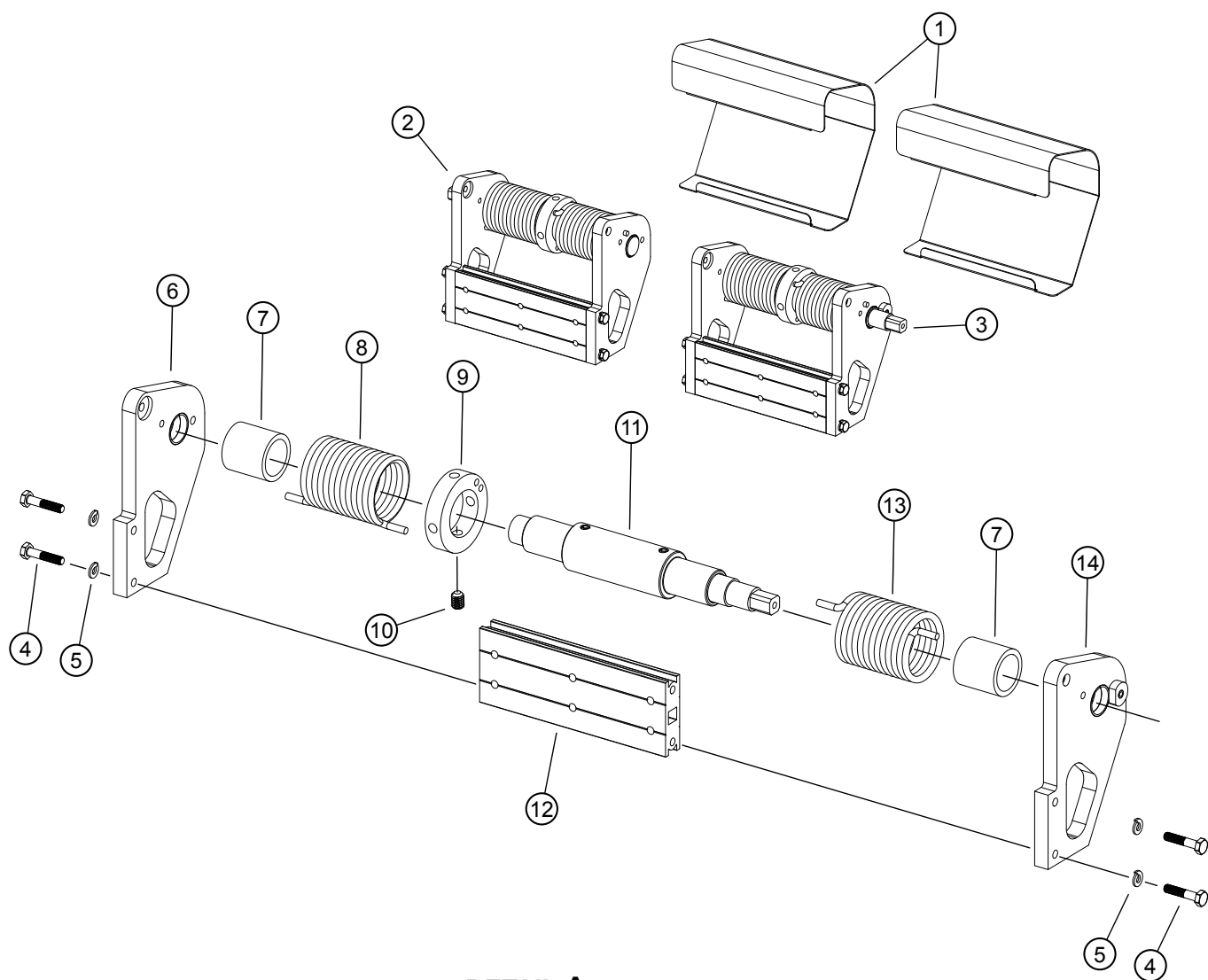

DETAIL A

PST28/E: PRO-MAX 2.0: 28" TWO SIDED GRILLS



Model: PST28 Hinge Assemblies

SK2918, Rev. - 7/29/15

PARTS LIST

July 30, 2015, Rev. -

Model: PST28 Detail A HINGE ASSY				
Fig No.	Part Number	Qty	Description	Application
1	D9-Z20627	2	HINGE COVER	
2	D9-GR0755	1	RIGHT HINGE ASSY.	
3	D9-GR0754	1	LEFT HINGE ASSY	
4	2C-41180	4	BOLT HEX 1/4-20X1 1/4	
5	2C-20204-02	4	WASHER SS 1/4 SPLIT LOCK	
6	PS-Z18469	1	PLATE ASSY, RIGHT SIDE	RIGHT SIDE HINGE
	PS-Z18469-1		PLATE ASSY, LEFT SIDE	LEFT SIDE HINGE
7	2K-Z18470	4	BUSHING, SPRING	
8	2P-Z18290	2	SPRNG,TORSION,SG14IRON,LH	
9	2V-Z20409	2	SPRING COLLAR, DOUBLE	
10	2C-Z20629	2	SET SCREW 1/4-20X.500	
11		2	SHAFT	
12	2I-Z20626	1	REAR HINGE MOUNT	
12	2I-Z20626	1	REAR HINGE MOUNT	
13	2P-Z18291	1	SPRNG,TORSION,SG14IRON,RH	
13	2P-Z18291	1	SPRNG,TORSION,SG14IRON,RH	
14	PS-Z18319	1	PLATE ASSY, RIGHT SIDE	RIGHT SIDE HINGE
	PS-Z18319-1		PLATE ASSY, LEFT SIDE	LEFT SIDE HINGE

PST28IE: PRO-MAX 2.0: 28" TWO SIDED GRILLS