



CONVEYOR TOASTER

MODEL

Q1-350, Q1-500B, Q1-35C

Installation and Operation Instructions

2M-Z9777 Rev. C 10/2018

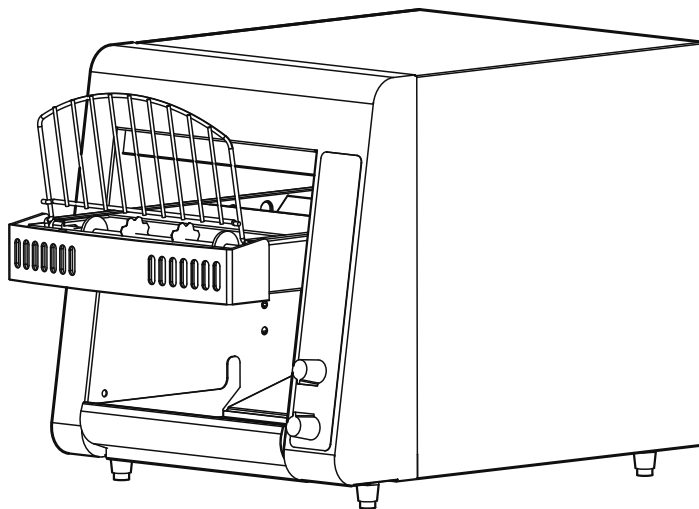

QCS1-350-120V



SAFETY SYMBOL



These symbols are intended to alert the user to the presence of important operating and maintenance instructions in the manual accompanying the appliance.

RETAIN THIS MANUAL FOR FUTURE REFERENCE NOTICE

Using any part other than genuine Star factory supplied parts relieves the manufacturer of all liability.

Star reserves the right to change specifications and product design without notice. Such revisions do not entitle the buyer to corresponding changes, improvements, additions or replacements for previously purchased equipment.

Due to periodic changes in designs, methods, procedures, policies and regulations, the specifications contained in this sheet are subject to change without notice. While Star International Holdings Inc., Company exercises good faith efforts to provide information that is accurate, we are not responsible for errors or omissions in information provided or conclusions reached as a result of using the specifications. By using the information provided, the user assumes all risks in connection with such use.

MAINTENANCE AND REPAIRS

Contact your local authorized service agent for service or required maintenance.

Please record the model number, serial number, voltage and purchase date in the area below and have it ready when you call to ensure a faster service.

Model No. _____
Serial No. _____
Voltage _____
Purchase Date _____

Authorized Service Agent Listing

Reference the listing provided with the unit

or

for an updated listing go to:

Website: www.star-mfg.com
E-mail customerservice@star-mfg.com

Service Help Desk

Business Hours: 8:00 am to 4:30 p.m. Central Standard Time

Telephone: (800) 264-7827

Fax: (314) 781-2714

E-mail customerservice@star-mfg.com

Website: www.star-mfg.com

Mailing Address: Star Manufacturing International Inc.
265 Hobson Street
Smithville, TN 37166
U.S.A

GENERAL INSTALLATION DATA



This equipment is designed and sold for commercial use only by personnel trained and experienced in its operation and is not sold for consumer use in and around the home nor for use directly by the general public in food service locations.

CAUTION

Before using your new equipment, read and understand all the instructions & labels associated with the unit prior to putting it into operation. Make sure all people associated with its use understand the units operation & safety before they use the unit.

All shipping containers should be checked for freight damage both visible and concealed. This unit has been tested and carefully packaged to insure delivery of your unit in perfect condition. If equipment is received in damaged condition, either apparent or concealed, a claim must be made with the delivering carrier.

Concealed damage or loss - if damage or loss is not apparent until after equipment is unpacked, a request for inspection of concealed damage must be made with carrier within 15 days. Be certain to retain all contents plus external and internal packaging materials for inspection. The carrier will make an inspection and will supply necessary claim forms.

INSPECTION & ASSEMBLY

UNCRATING AND INSPECTING

Unpack the unit and components from the shipping container. Remove all visible packing material and those from inside the cooking chamber. If damage is discovered, file a claim immediately with the carrier that handled the shipment. Do not operate the unit if it was damaged during shipping.

ASSEMBLY AND INSTALLATION

The unit was shipped fully assembled and ready to plug into a standard outlet specified for its voltage and amp draw. If improper electrical supply is determined, contact a qualified electrician prior to using the unit. Removal and replacement of the power cord and plug will void the warranty. For assistance, contact your local authorized service agent for service or required maintenance.

Level unit using the adjustable feet under the unit (approximately 1/2" adjustment).

Before using the unit for the first time, wipe down the exterior with a damp cloth.



CAUTION

Allow enough space around the toaster for adequate ventilation. Do not operate the unit without the crumb tray properly positioned. Overheating and poor toasting may occur. Read all labels on the unit and follow their instructions.

ELECTRICAL CONNECTION

Before making any electrical connection to this unit, check that the power supply is adequate for the voltage, amperage and requirements stated on the rating plate.

A wiring diagram is included herewith.

Disconnect the unit from the power source before installing or removing any parts.

Be absolutely sure that the ground connection for the receptacle is properly wired. Do not connect equipment to power without proper ground connections. Improper grounding may result in personal injury or fatality.



WARNING

DO NOT CUT OR REMOVE THIS PLUG OR GROUNDING PRONG FROM THE PLUG.



WARNING

CONNECT/PLUG UNIT INTO DEDICATED A.C. LINE ONLY SPECIFIED ON THE DATA PLATE OF THE UNIT.

DAILY OPERATION

ROTARY POWER SAVER SWITCH

For toasters equipped with a Rotary Power Saver Switch, turn clockwise or counterclockwise to get in the following positions.

FULL POWER

When in this position your equipment is at full power and ready to use.

OFF ROTARY

Two off positions are provided, a single rotation to either direction will shut the unit off.

STANDBY

The standby position reduces the power consumption by 75%. Using this position during the quiet times will save electricity, and keep the toaster warm. When needed, turn the switch to FULL POWER. Recovery time is about 30 seconds.



FAILURE TO PLACE THE UNIT IN LOW POWER MODE WHEN NOT IN USE WILL VOID THE WARRANTY.

CAUTION



CERTAIN SURFACES ARE EXTREMELY HOT DURING OPERATION AND CARE SHOULD BE TAKEN WHILE USING THIS UNIT.

WARNING

COOKING PROCEDURES

BREAD TOASTING

Some toasters are equipped with a swinging heat shutter at the toaster entrance. This shutter will move out of the way as the product passes under it.

- 1) Turn the power saver to FULL POWER.
- 2) Set the conveyor speed to 5.
- 4) Allow warm up time of 5 to 10 minutes.
- 5) Place a sample product on the conveyor belt to test the settings.

- If toasting is too light, turn conveyor speed control counterclockwise to a slower speed.
- If toasting is too dark, turn conveyor speed control clockwise to a faster speed.

(NOTE: Some products may require adjustment of the speed control in order to achieve the desired results.)

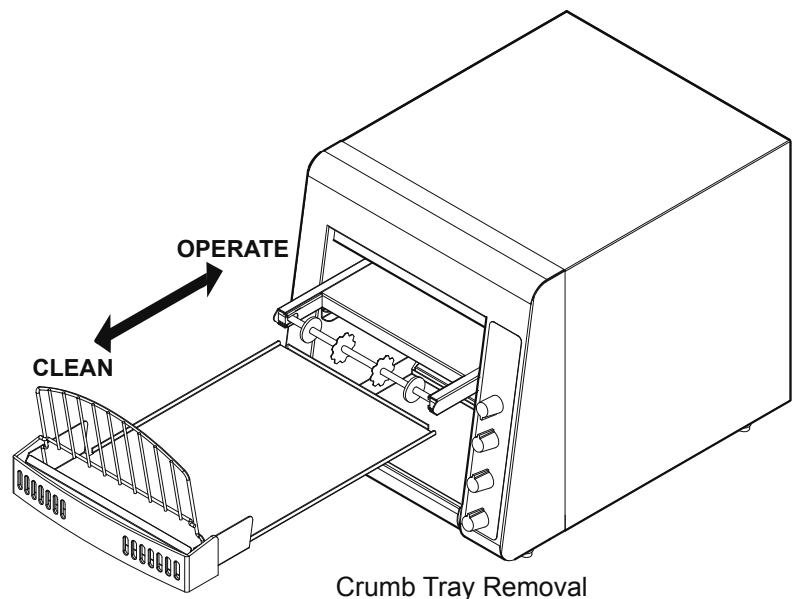

TOASTER COMPONENTS

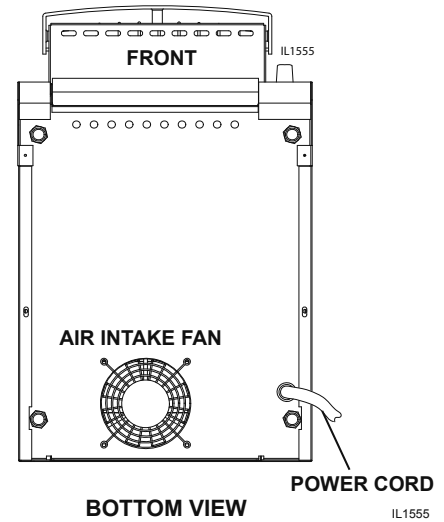
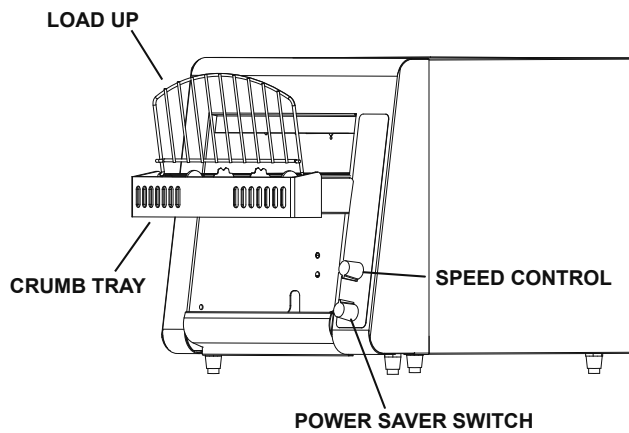

DAILY OPERATION

Check the power cord to insure that it is plugged into a proper outlet.

Set the Rotary Power Saver Switch & speed control knob to desired settings.

Always allow 10 minutes of preheat time before loading the unit with product. Failure to allow sufficient preheat time will result in unsatisfactory cooking until the unit reaches operating temperature.



OPERATING HINTS AND SAFETY

Disconnect power to the unit with the switch at the end of each day of operation.

Do not leave the unit in operation without an attendant.

Turn Power Saver Switch to Standby during idle periods. It will take only a few minutes to regain operating temperature.

Do not leave the unit at high temperature when not in use or during idle periods. This will cause food particles and grease film to carbonize.

CLEANING

Preventive maintenance for your Holman toaster consists of the following recommended cleaning procedures. To keep your toaster in its top operating condition, these steps should be performed on a daily or weekly as indicated.

- A. Turn main power saver switch to the OFF position. Disconnect unit from power source.
- B. After the unit cools, remove interior crumb tray (as shown on page 4) and clean. Slide crumb tray back into position.
- C. Wipe exterior surface of unit.
- D. Areas inside the toaster, be sure to unplug the unit and allow to cool prior to wiping clean with a damp cloth.
- E. Clean air intake on bottom of unit.
- F. For lightly soiled conveyor belts, turn conveyor speed control to fastest setting and wipe with a damp cloth (daily) For heavily soiled conveyors, turn conveyor speed control to fastest setting, with crumb tray installed and wipe with a light abrasive pad (as needed).

DO NOT IMMERSE OR LET THE UNIT STAND IN WATER.

DO NOT HOSE DOWN THE UNIT OR THE TABLE/COUNTER IF THE UNIT IS ON THE TABLE/COUNTER.

KEEP AWAY FROM RUNNING WATER.



WARNING

MAINTENANCE PROCEDURES

A. REPLACING HEATER TUBES

- 1) **DISCONNECT UNIT FROM POWER SOURCE.**
- 2) Remove the enclosure, by removing the screws on both the back and bottom of the unit and lifting the enclosure's back up first and pulling away from the unit.
- 3) Remove heater tube wires from terminal block connection, keeping top and bottom wires separate.
- 4) Lift heater tube retainers by loosening retaining screws and sliding the retainer plate. Hand tighten the plate to hold it up so the heater tubes will slide out freely.
- 5) Gently, pull defective heater tube out of unit.
- 6) Gently, put new heater tube into unit.
- 7) Loosen retainer screws and slide the retainer back into place. Tighten the screw to secure the retainer in place over the ends of the heater tubes.
- 8) Install the heater tube wires to the terminal block, and reinstall the enclosure.
- 9) Connect unit to power source and test by toasting some bread after unit has properly reached operating temperature.

B. REPLACING FAN MOTOR

- 1) **DISCONNECT UNIT FROM POWER SOURCE.**
- 2) Remove the enclosure, by removing the screws on both the back and bottom of the unit and lifting the enclosure's back up first and pulling away from the unit.
- 3) Remove the enclosure and the back panel.
- 4) Unplug power supply cord from fan motor.
- 5) Remove (4) screws, which hold fan motor and grill to bottom of unit and remove fan.
- 6) Put replacement motor and grill in place and secure to the bottom of unit with screws.
- 7) Reconnect power supply cord to fan motor.
- 8) Replace back panel and enclosure. Fasten with screws removed in step 2.

C. REPLACING BELT DRIVE MOTOR

- 1) **DISCONNECT UNIT FROM POWER SOURCE.**
- 2) Remove the enclosure, by removing the screws on both the back and bottom of the unit and lifting the enclosure's back up first and pulling away from the unit.
- 3) Remove sprocket from motor shaft, using an Allen wrench and loosening the set-screw.
- 4) Remove the wire from terminal block connecting the drive motor to internal wiring.
On units rated 208 or 240 volts, note which color leads are being used for these connections and which lead is capped with white tape. The new motor should use the same arrangement.
- 5) Remove screws holding motor in place and remove motor from unit.
- 6) Put new motor in place and attach loosely with mounting screws.
- 7) Replace sprocket on motor shaft.

NOTE: The two sprockets should line up FLUSH with each other, so the chain does not twist any during operation. Also the hub gets installed closets to the motor.

- 8) Slide motor until the drive chain has about 1/4" slack when lightly pushed at the center of its top open run.
See chain tensioning illustration.
- 9) Tighten screws to secure motor.
- 10) Rewire leads same as removed in step 4.
- 11) Replace side panel and control box cover.

D. CLEANING AIR INTAKE ONCE A WEEK.

- 1) **DISCONNECT UNIT FROM POWER SOURCE.**
- 2) Place unit on its backside.
- 3) Use a vacuum cleaner and or a damp cloth to clean the air intake. This procedure should be done at least once a week.

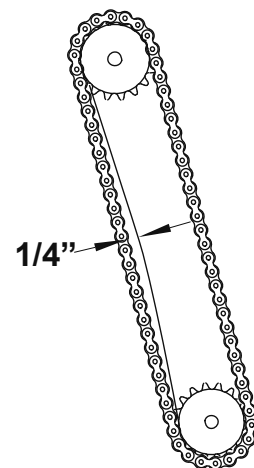

QCS/RCS Chain Tension

MAINTENANCE PROCEDURES continued

E. LUBRICATE THE CHAIN & SPROCKETS EVERY 6 MONTHS

- 1) **DISCONNECT UNIT FROM POWER SOURCE.**
- 2) Remove enclosure exposing chain drive.
- 3) Using an extreme pressure, synthetic chain lubricant with a temperature range up to 400°F. Apply liberally onto chain and sprockets. This grease is available as **part no. 1L-Z12397**.
- 4) Replace enclosure, Reconnect power source and test unit.

TROUBLESHOOTING GUIDE

A. UNIT WILL NOT HEAT, CONVEYOR BELT WILL NOT MOVE.

- 1) Be sure the main circuit breaker is switched to the ON position.
- 2) Check to see if the toaster is plugged in and all controls are turned to the ON position.
- 3) Call the Star Service Help Desk at 314-678-6303.

B. UNIT HAS HEAT ONLY ON ONE SIDE, CONVEYOR BELT TURNS FREELY.

- 1) Call the Star Service Help Desk at 314-678-6303, as heating element may need replacing.

C. CONVEYOR WILL NOT TURN, UNIT HEATS PROPERLY.

To check for mechanical binding:

- 1) **DISCONNECT UNIT FROM POWER SOURCE.**
- 2) Remove 2 screws holding enclosure to the bottom of the unit.
- 3) Set unit on the legs and remove 4 screws on the back of the toaster.
- 4) Slide the enclosure off the unit and remove the back panel.
- 5) Loosen the four screws that hold the drive motor in place.
- 6) Slide the motor up allowing the drive chain to be removed from the sprockets.
- 7) Move the conveyor belt by hand to check for mechanical binding.
If conveyor moves freely, call the Star Service Help Desk at 1-800-807-9054, as the drive motor and/or speed control may need replacing.
- 8) Replace the enclosure by sliding it forward towards the front of the unit.
The front edge of the enclosure will slide beneath the toaster front.

D. CONVEYOR TURNS AT ONE SPEED REGARDLESS OF SPEED CONTROL SETTING.

- 1) Call the Star Service Help Desk at 314-678-6303, as speed control **MAY** need replacing.

E. PRODUCT STICKING TO CONVEYOR OR SLIDE

Your Holman conveyor toaster is designed to toast product that is a current room temperature. **DO NOT** attempt to put frozen, refrigerated, or any butter or a butter substitute material in the toaster. Doing so may cause it to come out doughy or very moist, as well as possibly sticking to parts of the unit.

- 1) Follow the cleaning procedures listed on page 5.

LIMITED EQUIPMENT WARRANTY

Star Manufacturing [as well as its subsidiaries] warranties new products to be free from defects in material and/or workmanship for a period of one [1] year from the date of original installation, except as noted below. Defects that occur as a result of normal use, within the time period and limitations defined in this warranty, will at Star's discretion have the parts replaced or repaired by Star or a Star-authorized service agency.

THIS WARRANTY IS SUBJECT TO ALL LISTED CONDITIONS.

Repairs performed under this warranty are to be performed by a Star-authorized service agency. Star will not be responsible for charges incurred or service performed by non-authorized repair agencies. In all cases, the nearest Star-authorized service agency must be used.

Star will be responsible for normal labor charges incurred in the repair or replacement of a warrantied product within 50 miles (80.5 km) of an authorized service agency. Time and expense charges for anything beyond that distance will be the responsibility of the owner. All labor will need to be performed during regular service hours. Any overtime premium will be charged to the owner. For all shipments outside the U.S.A. and Canada, please see the International Warranty for specific details.

It is the responsibility of the owner to inspect and report any shipping damage claims, hidden or otherwise, promptly following delivery.

No mileage or travel charges will be honored on any equipment that is deemed portable. In general, equipment with a cord and plug weighing less than 50 lb. (22.7 kg) is considered portable and should be taken or shipped to the closest authorized service agency, transportation prepaid.

PORTABLE EQUIPMENT EXAMPLES

- 514LL fryer
- 12MCP and 18MCP hot food merchandisers
- QCS1, QCS2, and RCS2 toasters
- 16PD-A pretzel merchandisers
- condiment dispensers except HPD- and SPD-series models
- all pop-up toasters
- all pastry display cabinets
- all heat lamps
- J4R popcorn machine
- 12NCPW and 15NCPW nacho merchandisers
- nacho cheese warmers except 11WLA-series models
- specialty food warmers except 130R, 11RW, and 11WSA models
- all butter dispensers
- all nacho chip merchandisers
- all accessories

CONTACT

Should you require any assistance regarding the operation or maintenance of any Star equipment; write, phone, fax or email our service department. In all correspondence mention the model number and the serial number of your unit, as well as the voltage or type of gas you are using.

Business hours are 8:00 a.m. to 4:30 p.m. Central Standard Time
Telephone *Star/Toasmaster* 314.678.6306

Fax 314.781.2714

Email customerservice@star-mfg.com

www.star-mfg.com • www.toastmastercorp.com

WARRANTY EXCLUSIONS

THE FOLLOWING WILL NOT BE COVERED UNDER WARRANTY.

- Any product which has not been used, cleaned, maintained, or installed in accordance with the directions published in the appropriate installation sheet and/or owner's manual as well as national and local codes, including incorrect gas, electrical, or water connection. Star is not liable for any unit which has been mishandled, abused, misapplied, subjected to chlorides, harsh chemicals, or caustic cleaners, damaged from exposure to hard water, modified by unauthorized personnel, damaged by flood, fire, or other acts of nature [or God], or which have an altered or missing serial number.
- Installation, labor, and job checkouts, calibration of heat controls, air and gas burner/bypass/pilot adjustments, gas or electrical system checks, voltage and phase conversions, cleaning of equipment, or seasoning of griddle surface.
- Replacement of fuses or resetting of circuit breakers, safety controls, or reset buttons.
- Replacement of broken or damaged glass components, quartz heating elements, and light bulbs.
- Labor charges for all removable parts in gas charbroilers and hotplates, including but not limited to burners, grates, and radiants.
- Any labor charges incurred by delays, waiting time, or operating restrictions that hinder a service technician's ability to perform service.
- Parts that fail or are damaged due to normal wear or labor for replacement of Items that can easily be replaced during a daily cleaning routine. such as but not limited to silicone belts, PTFE non-stick sheets, knobs, control labels, bulbs, fuses, quartz heating elements, baskets, racks, and grease drawers.
- Components that should be replaced when damaged or worn, but have been field-repaired instead [eg. field-welded fry pots]
- Any loss of business or profits.

ADDITIONAL WARRANTIES

Specialty/chain specific versions may also have additional and/or extended warranties.

PRODUCTS	PARTS	LABOR
Star Ultra-Max® griddles, charbroilers, and hotplates	2 years	2 years
Star-Max® fryers, griddles, charbroilers, and hotplates	2 years	2 years
Jetstar® popcorn poppers	2 years	2 years
Staltek™ roller grill coatings	5 years	
chrome griddle surfaces [against peeling]	5 years	
cast iron grates, burners, and burner shields	180 days	
original Star or Toastmaster parts sold to repair Star or Toastmaster equipment	90 days	
Service First	1 year	

The foregoing warranty is in lieu of any and all other warranties expressed or implied and constitutes the entire warranty.

ZM-Z21647 • Rev D • 06.2018

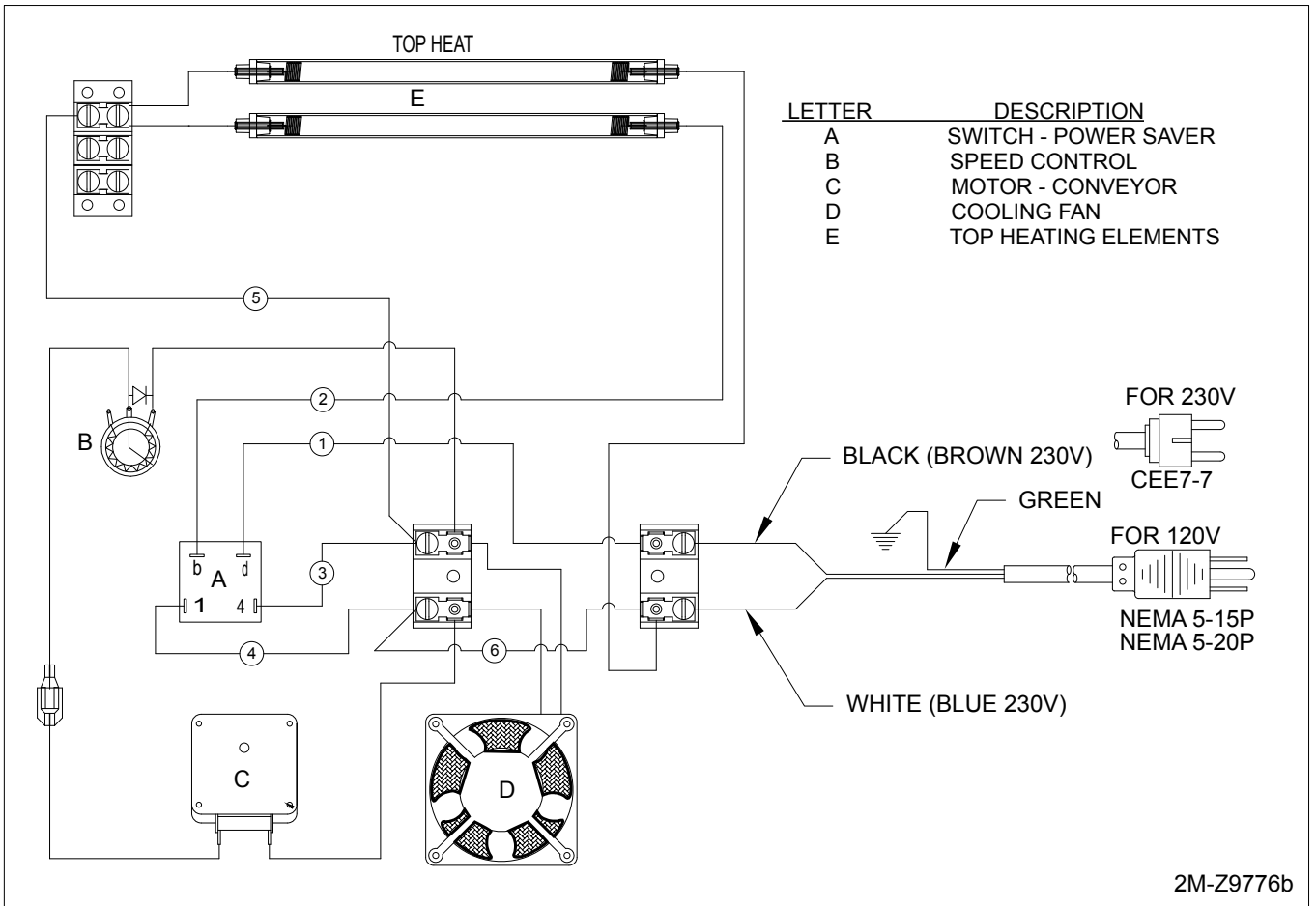
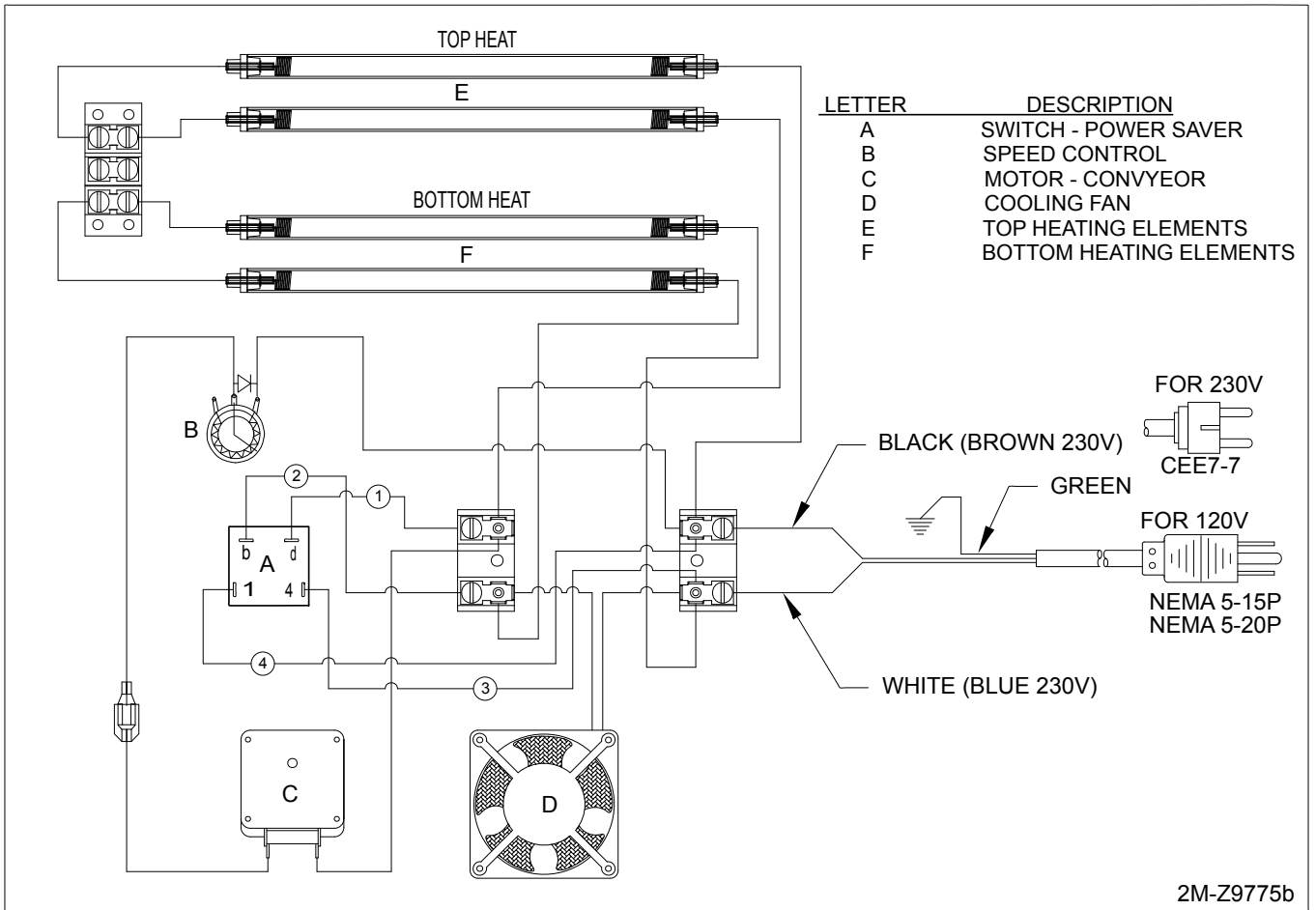

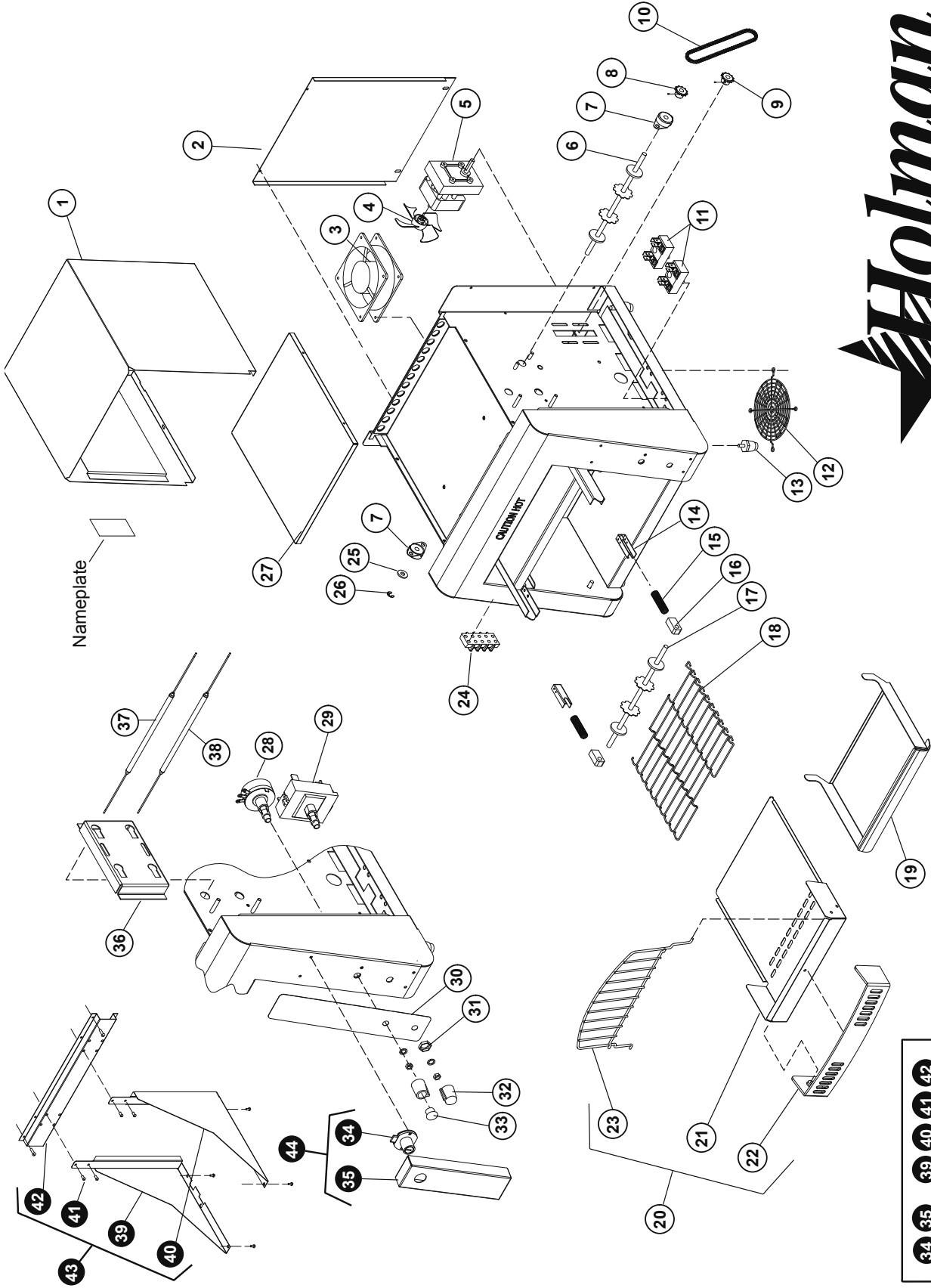

Nameplate



Rev. A 11/17/2011

SK2212

34 35 39 40 41 42
OPTIONAL ACCESSORY PARTS

MODEL: QCS1-350/500B-120V CONVEYOR TOASTER

THIS DRAWING CONTAINS INFORMATION CONFIDENTIAL TO HOLMAN.
NO REPRODUCTION OR DISCLOSURE OF ITS CONTENTS IS PERMITTED.

Model: Q1-350, Q1-500B, Q1-35C				
Fig No	Part No	Qty	Description	Application
1	HA-Z9786	1	BODY COVER	
2	HA-Z9745	1	BACK PANEL	
3	2U-200558	1	MOTOR, FAN 120V 15BTL	120V
	2U-200560		FAN 240V	230V
4	2R-Z8879	1	2-5/8" DIA FAN BLACK CW	
5	HA-120240	1	MOTOR ASSEMBLY	120V, CUL20, 350-CUL15
	HA-120243		MOTOR W/QC ASSY	230V
6	2A-202900	1	SHAFT, DRIVE	
7	HA-112261	2	BEARING ASSY, 5/16 BRONZE	
8	2P-200645	1	SPROCKET, 25B17 X 5/16", DRIVEN	
9	2P-200646	1	SPROCKET, 25B20 X 5/16", DRIVE	
10	2P-200665	1	CHAIN, 17 1/2"	Q1-350, Q1-500B
11	2E-Z9736	2	TERMINAL BLOCK - POWER	
12	2R-200562	1	FAN GUARD (OLDER MODELS)	
13	2R-200709	4	LEG 1 INCH CHROME PLASTIC	
	2R-Z18201		FOOT 1.69X1 SIL 1/4 20	Q1-35C, Q1-50BC
14	HA-Z9743	2	SPRING RETAINER	
15	2R-200736	2	2" INCH BEARING SPRING	
16	2P-200700	2	BEARING-PTFE SPRING LOADED	
17	2A-202904	1	SHAFT, IDLER	
18	HN-160020	1	CONVEYOR BELT (10" X 27")	
	2B-200601		LINK CONVEYOR BELT (10" WIDE)	
19	HA-100560	1	TRAY, PULL OUT, QCS 10"	
20	PS-120315	1	CRUMB TRAY ASSY	Q1-350 & 500
21	HA-Z9746	1	CRUMB TRAY	
22	PS-200787	1	CRUMB TRAY GUARD w/HARDWARE	
23	2B-200763	1	LOADUP, 10 EURO, WIRE	
24	2E-Z9737	1	TERMINAL BLOCK - ELEMENTS	
25	2C-200149	1	FLAT WASHER 5/16 ID 31NWX H8Z ZINC	
26	2A-200284	1	E-CLIP, 5/16"	
27	HA-Z9751	1	TOP LINER QCS-1	
28	HA-120239	1	SPEED CONTROL ASSEMBLY	
	HB-120261			230V
29	2E-200551	1	SWITCH ROTARY	
30	2M-Z9715	1	FRONT PANEL LABEL	
	2M-Z9759		LABEL - CONTROL	QCS1-500B
	2M-Z18430		FRONT PANEL LABEL	Q1-35C
	2M-Z18431		LABEL, QCS1-500-CONTROL	Q1-50BC
31	2C-200231	1	PALNUT, HEX, 3/8-24	
32	2R-200768	1	KNOB, CONTROL SERIES	
	2R-200769		KNOB, POWERSAVER SERIES	
	HA-120352		KNOB ASSY, CONTROL SPEED	Q1-35C, Q1-50BC
	HA-120353		KNOB ASSY, PWR SV-INF CNT	Q1-35C, Q1-50BC
33	2P-200708	2	CAP, KNOB CONTROL	
34	2R-200752	1	KEYLOCK SPEC KEYED ALIKE_KEY LOCKING ACCESSORY	
35	HF-Z9835	1	SECURITY LOCKING COVER_KEY LOCKING ACCESSORY	
36	HA-Z9744	1	ELEMENT RETAINER	

Model: Q1-350, Q1-500B, Q1-35C				
Fig No	Part No	Qty	Description	Application
37	HA-120231	2	HEATER ASSY 350W 60V - TOP	Q1-350-120V, Q1-CUL20
	HA-120233		HEATER ASSY 300W 60V-TOP	Q1-CUL15
	HA-120235		HEATER ASSY 350W 115V-TOP	Q1-350-230V
	HA-120237		HEATER ASSY 800W 120V-TOP	Q1-500B-120V
	HA-120238		HEATER ASSY 800W 115V-TOP	Q1-500B-230V
38	HA-120232	2	HEATER ASSY 450W 60V - BTM	Q1-350-120V, Q1-CUL20
	HA-120234		HEATER ASSY 400W 60V -BTM	Q1-CUL15
	HA-120236		HEATER ASSY 450W 115V-BTM	Q1-350-230V
39	HF-102215	1	ASSEMBLY BRACKET LEFT_WALL MOUNTING ACCESSORY	
40	HF-102214	1	ASSEMBLY BRACKET RIGHT_WALL MOUNTING ACCESSORY	
41	HF-100211	1	PLATE ASSY. _WALL MOUNTING ACCESSORY	
42	2C-200041	8	SCREW, 1/4-20 X 1/2 SLOT_WALL MOUNTING ACCESSORY	
NI	HA-120241	1	CORD SET ASSEMBLY QCS-1	350-120V, CUL15, 500B-120V
NI	HA-120242	1	CORDSET ASSY	CUL20
NI	HA-120244	1	CORDSET ASSY	QCS1-230CE
NI	HA-120245	1	CORDSET ASSY NEMA 6-20P	230V
NI	HA-120328	1	CORD SET ASSY Q1-AUS	230AU
NI	1L-Z12397	1	CHAIN LUB, 1oz TRIBOLUBE GREASE (80°F TO 400°F)	
NI	2K-Y3240	1	BUSHING HEYCO SR 17-2, CORD	
NI	2K-200464	1	BUSHING, WIRE RING 7/8"	
ACCESSORIES (Not necessarily sold with unit)				
43	WMK-QCS		KIT-QCS WALL MOUNT	
44	KLK-QCS1		QCS-1 LOCKING KIT	

STAR MANUFACTURING INTERNATIONAL INC.
 Star - Holman - Lang - Wells - Toastmaster
 265 HOBSON ST. SMITHVILLE, TN 37166
 (800) 264-7827
www.star-mfg.com