

Holman[®] **CONVEYOR TOASTER**

MODEL
QCS2, QCSe2, RCS2, R2e SERIES
QCS3, QCSe3 SERIES

Installation and Operation Instructions

2M-Z10651 Rev. G 1/26/2015

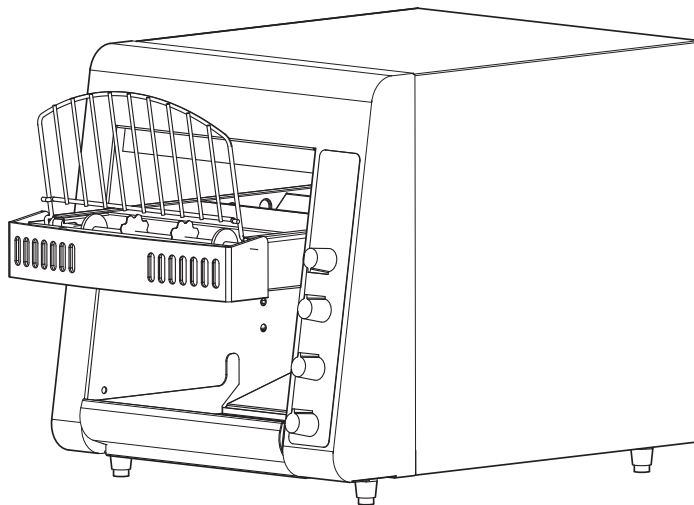

Q2-600H-208V



SAFETY SYMBOL



These symbols are intended to alert the user to the presence of important operating and maintenance instructions in the manual accompanying the appliance.

RETAIN THIS MANUAL FOR FUTURE REFERENCE NOTICE

Using any part other than genuine Star factory supplied parts relieves the manufacturer of all liability.

Star reserves the right to change specifications and product design without notice. Such revisions do not entitle the buyer to corresponding changes, improvements, additions or replacements for previously purchased equipment.

Due to periodic changes in designs, methods, procedures, policies and regulations, the specifications contained in this sheet are subject to change without notice. While Star International Holdings Inc., Company exercises good faith efforts to provide information that is accurate, we are not responsible for errors or omissions in information provided or conclusions reached as a result of using the specifications. By using the information provided, the user assumes all risks in connection with such use.

MAINTENANCE AND REPAIRS

Contact your local authorized service agent for service or required maintenance.

Please record the model number, serial number, voltage and purchase date in the area below and have it ready when you call to ensure a faster service.

Model No. _____
Serial No. _____
Voltage _____
Purchase Date _____

Authorized Service Agent Listing

Reference the listing provided with the unit

OR

for an updated listing go to:

Website: www.star-mfg.com
E-mail customerservice@star-mfg.com

Service Help Desk

Business Hours: 8:00 am to 4:30 p.m. Central Standard Time

Telephone: (314) 678-6303

Fax: (314) 781-2714

E-mail customerservice@star-mfg.com

Website: www.star-mfg.com

Mailing Address: Star International Holdings Inc., Company
10 Sunnen Drive
St. Louis, MO 63143
U.S.A

TABLE OF CONTENTS

General Installation Data	4
Uncrating & Inspection.....	4
Assembly & Installation	4
Electrical Connection.....	4
QCS & RCS	
Operation.....	5
Cooking Procedures	5
Toaster Components.....	5
Daily Operation	6
Operating Hints & Safety	6
QCSe & RCSe	
QCSe Operation	7
Start-up	8
Daily Operation	8
Operating Hints & Safety.....	8
Toaster Components	8
Programing	
Conveyor Speed.....	9
Programing Values for Menu Items	9
Cleaning	10
Maintenance Procedures	11
Trouble Shooting Guide.....	12
Warranty.....	13
Wiring Diagrams	
QCS2 & 3, RCS2 & 3, wired series	14
QCS2 & 3, RCS2 & 3, wired parallel	14
QCS2 & 3, RCS2 & 3, 3 wired in series	15
QCS2, RCS2 w/fan switch series	15
QCS2 & 3, RCS2 & 3, 3 wired in series w/bun mode	16
QCSe, 4 wired in series	16
QCSe, 6 wired in series	17
QCSe, 6 wired in parallel	17
QCS3, 6 wired in series, with fuses.....	18
R2-600N & R2-600BN	18
Exploded View / Parts List	
R2-600N (Narrow)	20
QCS2 & 3, RCS2 & 3	22



GENERAL INSTALLATION DATA

This equipment is designed and sold for commercial use only by personnel trained and experienced in its operation and is not sold for consumer use in and around the home nor for use directly by the general public in food service locations.

Before using your new equipment, read and understand all the instructions & labels associated with the unit prior to putting it into operation. Make sure all people associated with its use understand the units operation & safety before they use the unit.

All shipping containers should be checked for freight damage both visible and concealed. This unit has been tested and carefully packaged to insure delivery of your unit in perfect condition. If equipment is received in damaged condition, either apparent or concealed, a claim must be made with the delivering carrier.

Concealed damage or loss - if damage or loss is not apparent until after equipment is unpacked, a request for inspection of concealed damage must be made with carrier within 15 days. Be certain to retain all contents plus external and internal packaging materials for inspection. The carrier will make an inspection and will supply necessary claim forms.

INSPECTION & ASSEMBLY

UNCRATING AND INSPECTING

Unpack the unit and components from the shipping container. Remove all visible packing material and those from inside the cooking chamber. If damage is discovered, file a claim immediately with the carrier that handled the shipment. Do not operate the unit if it was damaged during shipping.

ASSEMBLY AND INSTALLATION

The unit was shipped fully assembled and ready to plug into a standard outlet specified for its voltage and amp draw. If improper electrical supply is determined, contact a qualified electrician prior to using the unit. Removal and replacement of the power cord and plug will void the warranty. For assistance, contact your local authorized service agent for service or required maintenance.

Level unit using the adjustable feet under the unit (approximately 1/2" adjustment).

Before using the unit for the first time, wipe down the exterior with a damp cloth.

Allow enough space around the toaster for adequate ventilation. Do not operate the unit without the crumb tray properly positioned. Overheating and poor toasting may occur. Read all labels on the unit and follow their instructions.



ELECTRICAL CONNECTION

Before making any electrical connection to this unit, check that the power supply is adequate for the voltage, amperage and requirements stated on the rating plate.

A wiring diagram is included herewith.

Disconnect the unit from the power source before installing or removing any parts.



Be absolutely sure that the ground connection for the receptacle is properly wired. Do not connect equipment to power without proper ground connections. Improper grounding may result in personal injury or fatality.

DO NOT CUT OR REMOVE THIS PLUG OR GROUNDING PRONG FROM THE PLUG.



CONNECT/PLUG UNIT INTO DEDICATED A.C. LINE ONLY SPECIFIED ON THE DATA PLATE OF THE UNIT.

OPERATION

ROTARY POWER SAVER SWITCH

For toasters equipped with a Rotary Power Saver Switch, turn clockwise or counterclockwise to get in the following positions.

FULL POWER

When in this position your equipment is at full power and ready to use.

OFF ROTARY

Two off positions are provided, a single rotation to either direction will shut the unit off.

STANDBY

The standby position reduces the power consumption by 75%. Using this position during the quiet times will save electricity, and keep the toaster warm. When needed, turn the switch to FULL POWER. Recovery time is about 30 seconds.



CERTAIN SURFACES ARE EXTREMELY HOT DURING OPERATION AND CARE SHOULD BE TAKEN WHILE USING THIS UNIT.

COOKING PROCEDURES

BREAD TOASTING

Some toasters are equipped with a swinging heat shutter at the toaster entrance. This shutter will move out of the way as the product passes under it.

- 1) Turn the power saver to FULL POWER.
- 2) Set the conveyor speed to HIGH.
- 3) If your toaster is equipped with separate top and bottom heat controls set them both at HIGH.
- 4) Allow warm up time of 5 to 10 minutes.
- 5) Place a sample product on the conveyor belt to test the settings.
 - If toasting is too light, turn conveyor speed control counterclockwise to a slower speed.
 - If toasting is too dark, turn heat control to a lower heat.

(NOTE: Some products may require adjustment of the top and bottom heat controls in order to achieve the desired results)

TOASTER COMPONENTS

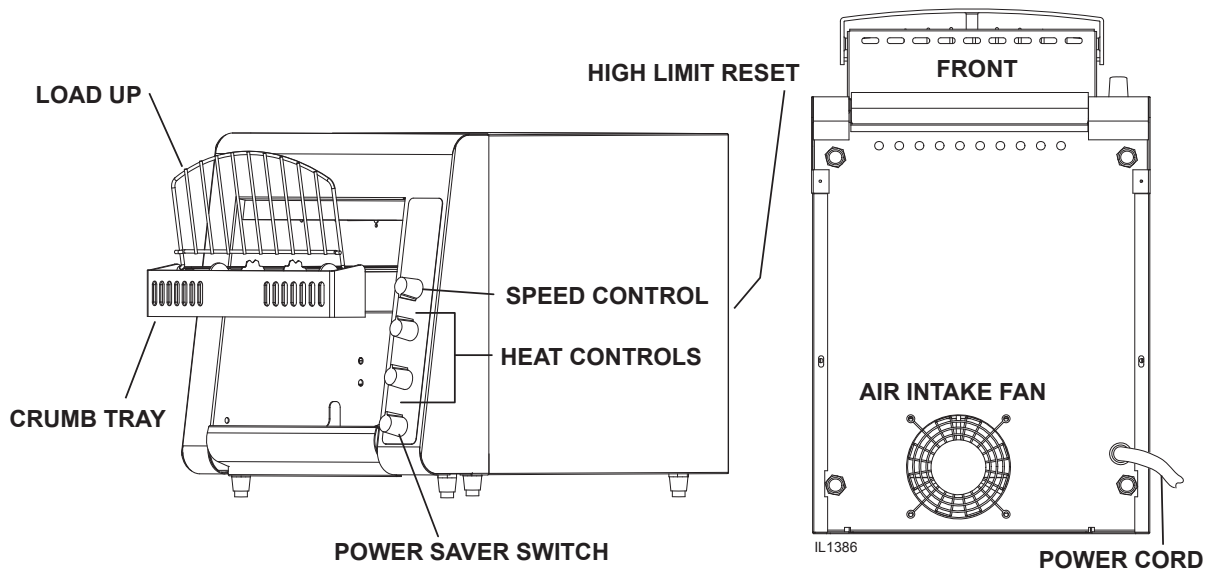



DAILY OPERATION

Check the power cord to insure that it is plugged into a proper outlet.

Set the heat control knobs to desired temperature.

Always allow 10 minutes of preheat time before loading the unit with product. Failure to allow sufficient preheat time will result in unsatisfactory cooking until the unit reaches operating temperature.

OPERATING HINTS AND SAFETY

Disconnect power to the unit with the switch at the end of each day of operation.

Do not leave the unit in operation without an attendant.

Turn Power Saver Switch to Standby during idle periods. It will take only a few minutes to regain operating temperature.

Do not leave the unit at high temperature when not in use or during idle periods.

This will cause food particles and grease film to carbonize.



QCS_e & RCS_e OPERATION

The Holman QCS_e conveyor toaster comes with pre-programmed factory default settings for TOAST, MUFFINS, and BAGELS. The operator may change these setting at any time. A button labeled OTHER is provided to allow the operator to program settings for additional product(s).

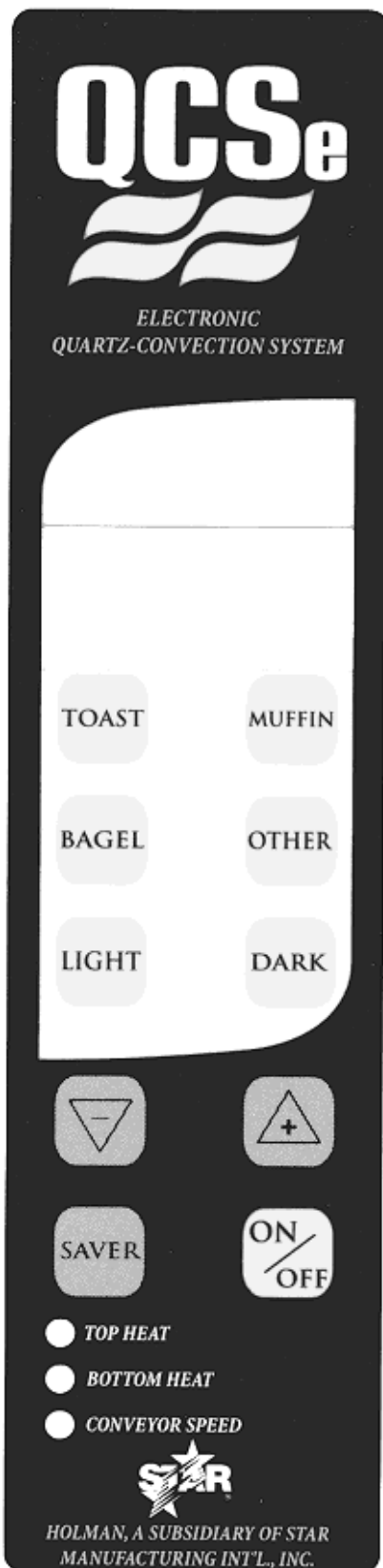

Press TOAST and TST will appear in the display.

Press MUFFIN and MUF will appear in the display.

Press BAGEL and BGL will appear in the display.

Press OTHER and OTH will appear in the display.

LIGHT and **DARK** buttons are used to change the conveyor speeds when in toast, muffin, or bagel modes.

Pressing the (**LIGHT**) button once will increase the conveyor speed by 15%. Pressing twice (**XLIGHT**) will increase the conveyor speed by 30%.

Pressing the (**DARK**) button once will decrease the conveyor speed by 10%. Pressing twice (**XDARK**) will decrease the conveyor speed by 20%.

Note: After 60 seconds the conveyor speed will return to the pre-programmed setting.

The factory default settings are as follow:

TOAST AND OTHER

TOP HEAT	9
BOTTOM HEAT	9
CONVEYOR	59

BAGEL:

TOP HEAT	9
BOTTOM HEAT	9
CONVEYOR	24

OTHER:

TOP HEAT	9
BOTTOM HEAT	9
CONVEYOR	59

POWER SAVER:

TIME (minutes)	60
HEAT	5

The QCS_e toaster is equipped with a Power Saver Switch (SAVER) that reduces the power used by the toaster after a pre-programmed period of time. This Power Saver Switch has three modes:

ON: Unit is in pre-programmed power saving setting.

OFF: Power Saver mode is turned off.

AUTO ON: Power Saver turns on when there has been no activity for a programmed length of time.

The operator may adjust the level of power reduction for the saver mode. (Note: conveyor may move slowly when in saver mode.)

Two buttons (+) and (-) are used when increasing or decreasing the value of each programmable setting.

A red LED light located at the lower portion of the control panel label will indicate if the value for top heat, bottom heat or conveyor speed is being adjusted.



CAUTION

CERTAIN SURFACES ARE EXTREMELY HOT DURING OPERATION AND CARE SHOULD BE TAKEN WHILE USING THIS UNIT.

START UP

When the toaster has been plugged into a suitable outlet and power supply, the word **OFF** will be displayed on the L.E.D. read out.

- A. Press the **ON/OFF** button once to turn on the toaster. The toaster will now enter into pre-heat and **PREHT** will be displayed (the elements will begin to glow but the conveyor and fan motor will not turn on).
- B. **After one minute**, the fan motor will turn on and the conveyor will begin turning at the previously saved setting (for initial start up, the drive motor will operate at the factory default setting).
- C. **After four minutes**, the display will show the last used program selection i.e. **TOAST, BAGEL, MUFFIN** or **OTHER** (for initial startup, **TOAST** will be the last program selected).

DAILY OPERATION

Check the power cord to insure that it is plugged into a proper outlet.
 Press the **ON/OFF** button once to turn the toaster on.
 Press the button a second time to turn the toaster off.

NOTE: When the toaster is turned off, the fan and conveyor motors will continue to run for five minutes. The words **COOL** and **DOWN** will be alternately displayed during that time. After five minutes, the word **OFF** will be displayed until the **ON/OFF** button is pressed again.

For units equipped with a **POWER SAVER** feature, the three operating modes are:

- ON** Unit has entered the pre-programmed level of power savings.
- OFF** Power Saver feature is turned off.
- AUTO** If the toaster has been idle for a pre-set period of time, the unit enters Power Saver mode until one of the menu buttons has been pressed.

Once the toaster has been pre-heated, the menu buttons can be pressed to change to **TOAST, BAGEL, MUFFIN**, or **OTHER**.

OPERATING HINTS AND SAFETY

Disconnect power to the unit with the **ON/OFF** button at the end of each day of operation.

Do not leave the unit in operation without an attendant.

Do not leave the unit at high temperature when not in use or during idle periods. This will cause food particles and grease film to carbonize.



CAUTION

TOASTER COMPONENTS

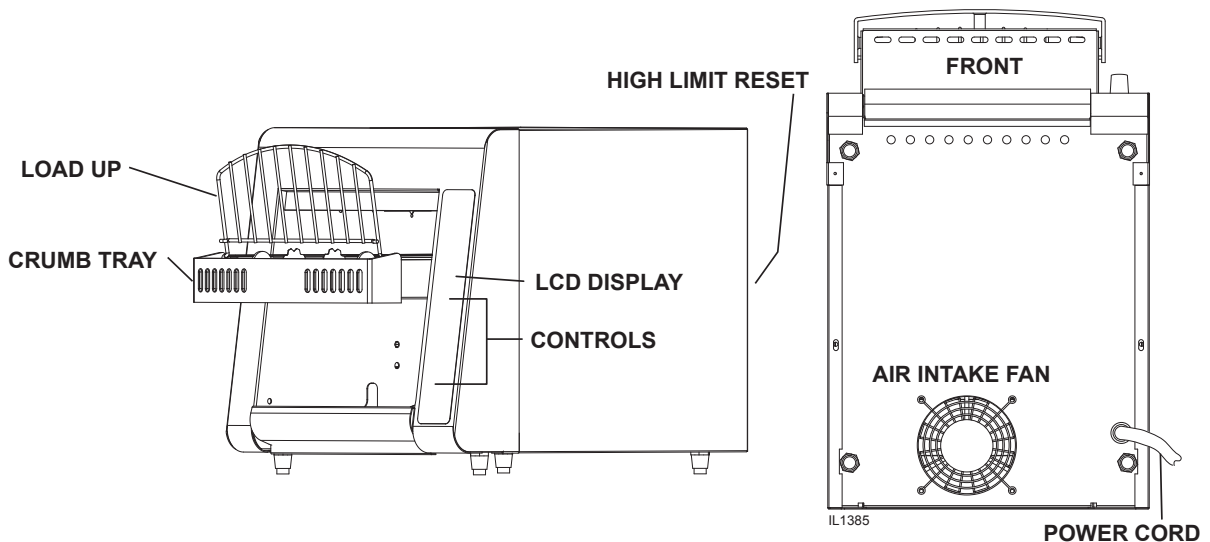

PROGRAMING

A. CONVEYOR SPEED (temporary setting)

The conveyor speed is programmable with a range from 0 to 99 with 0 being the slowest and 99 being the fastest. Each menu item can have independent conveyor speed settings.

The *LIGHT* and *DARK* buttons can be used to temporarily change the conveyor speed.

Pressing the *LIGHT* button once will increase the conveyor speed by 15%. The word **LIGHT** will be displayed. Pressing twice will increase the conveyor speed by 30% and **XLIGHT** will now be displayed.

Pressing the *DARK* button once will decrease the conveyor speed by 15%. The word **DARK** will be displayed. Pressing twice will decrease the conveyor speed by 30% and **XDARK** will now be displayed.

NOTE: After 60 seconds, the conveyor speed will return to the pre-programmed setting.

WHEN USING THE LIGHT AND DARK BUTTONS TO ADJUST THE CONVEYOR SPEED FOR A SINGLE ORDER OF PRODUCT, IT IS IMPORTANT TO REMEMBER TO ALLOW THE PRODUCT ALREADY IN THE TOASTER TO EXIT BEFORE CHANGING THE SPEED SETTING.

B. PROGRAMING VALUES FOR MENU ITEMS

To make a program change to the top heat, bottom heat, or conveyor speed, you must first be in the menu item you want changed. Example: to change the programmed conveyor speed for bagels, the display must read **BAGEL**. To change the programmed conveyor speed for TOAST, the display must read **TOAST** and so on for each menu item.

- 1) Select the menu item you want to change i.e. **TOAST, MUFFIN, BAGEL** or **OTHER**.
- 2) Press and hold both (+) AND (-) buttons for 3 seconds until the display goes blank, release the buttons and the display will show three characters for the menu item elected and the last two characters for the current value setting, i.e. **TST, MUF, BGL** and **OTH**. The red L.E.D. light for top heat at the bottom of the label will flash.
- 3) Press the (+) or (-) buttons to increase or decrease the setting for the top heat.
- 4) Press the button for the menu button again and the red L.E.D. for the bottom heat will flash.
- 5) Press the (+) or (-) buttons to increase or decrease the setting for the bottom heat.
- 6) Press the button for the menu button again and the red L.E.D. for the conveyor speed will flash.
- 7) Press the (+) or (-) buttons to increase or decrease the setting for the conveyor speed.
- 8) To skip one feature setting with out making any changes, press the menu item button one time and the red L.E.D. light for the next item will now flash.
- 9) To change the POWER SAVER values press the SAVER button or to save your new setting(s), and exit the program mode press the menu button.
- 10) The last two characters in the display will show **MN** for minutes.
- 11) The first three characters will be numerical to represent the time setting.
- 12) Press the (+) or (-) buttons to increase or decrease the setting for the savor mode time. The minimum value is **15** minutes to maximum value of **480** minutes.
- 13) Press the SAVER button to change the power reduction using the (+) or (-) buttons to increase or decrease the setting.
- 14) Press the POWER SAVER button to save changes and to exit.

QCS

QCS_e

CLEANING

Preventive maintenance for your Holman toaster consists of the following recommended cleaning procedures. To keep your toaster in its top operating condition, these steps should be performed on a daily or weekly as indicated.

- A. Clean air intake on bottom of unit.
- B. For lightly soiled conveyor belts, turn conveyor speed control to fastest setting (100) and wipe with a damp cloth (daily) For heavily soiled conveyors, turn conveyor speed control to fastest setting and wipe with a light abrasive pad (as needed).
- C. Turn main power saver switch to the OFF position. Disconnect unit from power source.
- D. After the unit cools, remove interior crumb tray (as shown below) and clean. Slide crumb tray back into position.
- E. Wipe exterior surface of unit.

DO NOT IMMERSE OR LET THE UNIT STAND IN WATER.

DO NOT HOSE DOWN THE UNIT OR THE TABLE/COUNTER IF THE UNIT IS ON THE TABLE/COUNTER.

KEEP AWAY FROM RUNNING WATER.



WARNING

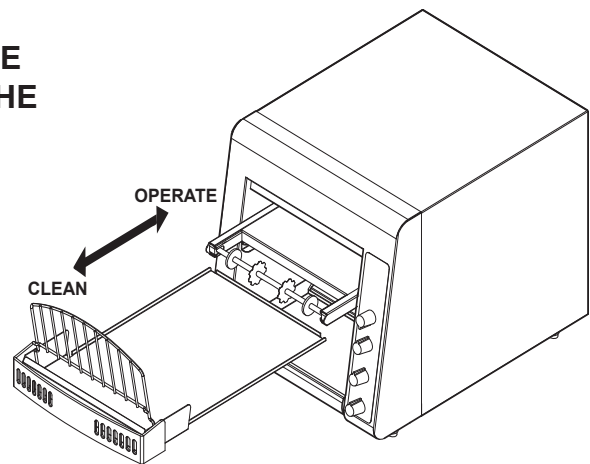

CRUMB TRAY REMOVAL

MAINTENANCE PROCEDURES

A. REPLACING HEATER TUBES

- 1) **DISCONNECT UNIT FROM POWER SOURCE.**
- 2) Remove the enclosure.
- 3) Remove heater tube wire from terminal block connection, keeping top and bottom wires separate.
- 4) Lift heater tube retainers by loosening retaining screws and sliding the retainer plate up. Hand tighten the plate to hold it up so the heater tubes will slide out freely.
- 5) Gently, pull defective heater tube out of unit.
- 6) Gently, put new heater tube into unit.
- 7) Loosen retainer screws and slide the retainer back into place. Tighten the screw to secure the retainer in place over the ends of the heater tubes.

B. REPLACING FAN MOTOR

- 1) **DISCONNECT UNIT FROM POWER SOURCE.**
- 2) Remove screws from the enclosure and the back panel at rear of unit.
- 3) Remove the enclosure and the back panel.
- 4) Unplug power supply cord from fan motor.
- 5) Remove (4) screws, which hold fan motor and grill to bottom of unit and remove fan.
- 6) Put replacement motor and grill in place and secure to the bottom of unit with screws.
- 7) Reconnect power supply cord to fan motor.
- 8) Replace back panel and enclosure. Fasten with screws removed in step 2.

C. REPLACING BELT DRIVE MOTOR

- 1) **DISCONNECT UNIT FROM POWER SOURCE.**
- 2) Remove enclosure and back panel.
- 3) Remove sprocket from motor shaft, using an Allen wrench and loosening the set-screw.
- 4) Remove the wire from terminal block connecting the drive motor to internal wiring.
On units rated 208 or 240 volts, note which color leads are being used for these connections and which lead is capped with white tape. The new motor should use the same arrangement.
- 5) Remove screws holding motor in place and remove motor from unit.
- 6) Put new motor in place and attach loosely with mounting screws.
- 7) Replace sprocket on motor shaft.

NOTE: The two sprockets should line up parallel with each other, so the chain does not twist any during operation. Also the hub gets installed closets to the motor.

- 8) Slide motor until the drive chain has about 1/4" slack when lightly pushed at the center of its top open run. *See chain tensioning illustration.*
- 9) Tighten screws to secure motor.
- 10) Rewire leads same as removed in step 4.
- 11) Replace side panel and control box cover.

D. CLEANING AIR INTAKE ONCE A WEEK

- 1) **DISCONNECT UNIT FROM POWER SOURCE.**
- 2) Place unit on its backside.
- 3) Use a vacuum cleaner and or a damp cloth to clean the air intake. This procedure should be done at least once a week.

E. LUBRICATE THE CHAIN & SPROCKETS EVERY 6 MONTHS

- 1) **DISCONNECT UNIT FROM POWER SOURCE.**
- 2) Remove enclosure exposing chain drive.
- 3) Using an extreme pressure, synthetic chain lubricant with a temperature range up to 400°F. Apply liberally onto chain and sprockets. This grease is available as part no. **1L-Z12397.**
- 4) Replace enclosure, Reconnect power source and test unit.

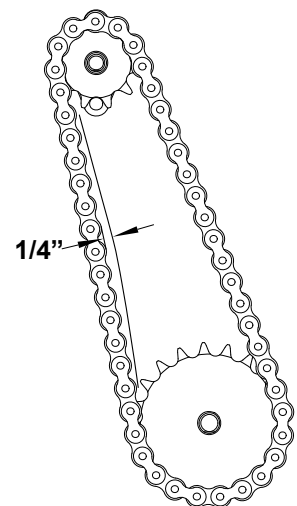

QCS/RCS Chain Tension

TROUBLESHOOTING GUIDE

A. UNIT WILL NOT HEAT, CONVEYOR BELT WILL NOT MOVE.

- 1) Be sure the main circuit breaker is switched to the ON position.
- 2) Check to see if the toaster is plugged in and all controls are turned to the ON position.

B. UNIT HAS HEAT ONLY ON ONE SIDE, CONVEYOR BELT TURNS FREELY.

- 1) Call the Star Service Help Desk at (314) 678-6303, as heating element may need replacing.

C. CONVEYOR WILL NOT TURN, UNIT HEATS PROPERLY.

To check for mechanical binding:

- 1) **DISCONNECT UNIT FROM POWER SOURCE.**
- 2) Remove 2 screws holding enclosure to the bottom of the unit.
- 3) Set unit on the legs and remove 4 screws on the back of the toaster.
- 4) Slide the enclosure off the unit and remove the back panel.
- 5) Loosen the four screws that hold the drive motor in place.
- 6) Slide the motor up allowing the drive chain to be removed from the sprockets.
- 7) Move the conveyor belt by hand to check for mechanical binding. If conveyor moves freely, call the Star Service Help Desk at (314) 678-6303, as the drive motor and/or speed control may need replacing.
- 8) Replace the enclosure by sliding it forward towards the front of the unit.
The front edge of the enclosure will slide beneath the toaster front.

D. HEAT LIMIT SWITCH (RESET)

Your Holman conveyor toaster is equipped with an automatically activated heat limit switch that interrupts the heater tube connections if the ambient temperature in the control box exceeds 190°F (88C). This switch can be reset manually by pushing the red button under the toaster as shown in the Toaster Components Illustration on Page 5 & 8.

- 1) **DISCONNECT UNIT FROM POWER SOURCE.**
- 2) Check to see if air intake area in the bottom center of the control box cover is free of dust, grease or other obstructions.
- 3) Check if crumb tray is in place. **NEVER OPERATE UNIT WITHOUT CRUMB TRAY IN PLACE AS THIS CAUSES OVERHEATING IN THE CONTROL BOX.**
- 4) If no obstructions to the airflow can be found and if the crumb tray is in place, call the Star Service Help Desk at (314) 678-6303 or email; service@star-mfg.com for assistance, or contact an authorized service agent near you.

E. CONVEYOR TURNS AT ONE SPEED REGARDLESS OF SPEED CONTROL SETTING.

- 1) Call the Star Service Help Desk at (314) 678-6303 or email; service@star-mfg.com, as speed control should be replaced, or contact an authorized service agent near you.

F. PRODUCT STICKING TO CONVEYOR OR SLIDE

Your Holman conveyor toaster is designed to toast product that is at current room temperature. **DO NOT** attempt to put frozen, refrigerated, or any butter or a butter substitute material in the toaster. Doing so may cause it to come out doughy or very moist, as well as possibly sticking to parts of the unit.

- 1) Follow the cleaning procedures listed on page 10.