

# **Holman**<sup>®</sup> **CONVEYOR TOASTER**

MODEL  
QCS-2, QCS-3,  
RCS-2, RCS-3 SERIES

## **Installation and Operation Instructions**

2M-HG0651 Rev. J 2/6/2012

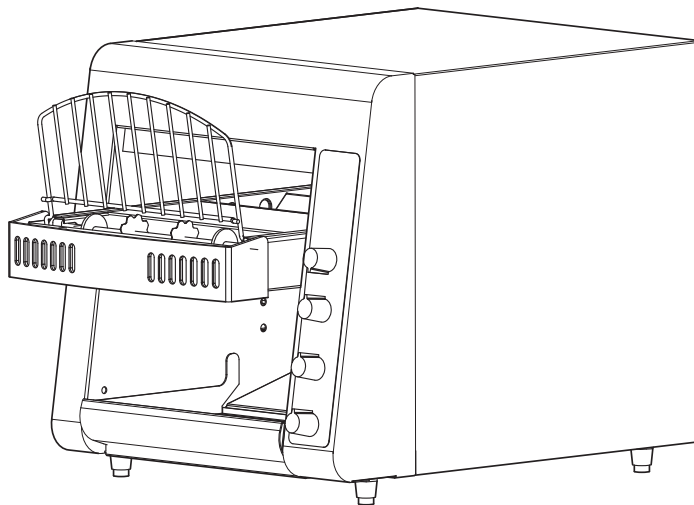

QCS-2



## SAFETY SYMBOL



These symbols are intended to alert the user to the presence of important operating and maintenance instructions in the manual accompanying the appliance.

---

## RETAIN THIS MANUAL FOR FUTURE REFERENCE NOTICE

Using any part other than genuine Star factory supplied parts relieves the manufacturer of all liability.

Star reserves the right to change specifications and product design without notice. Such revisions do not entitle the buyer to corresponding changes, improvements, additions or replacements for previously purchased equipment.

Due to periodic changes in designs, methods, procedures, policies and regulations, the specifications contained in this sheet are subject to change without notice. While Star International Holdings Inc., Company exercises good faith efforts to provide information that is accurate, we are not responsible for errors or omissions in information provided or conclusions reached as a result of using the specifications. By using the information provided, the user assumes all risks in connection with such use.

## MAINTENANCE AND REPAIRS

Contact your local authorized service agent for service or required maintenance.

Please record the model number, serial number, voltage and purchase date in the area below and have it ready when you call to ensure a faster service.

Model No. \_\_\_\_\_  
Serial No. \_\_\_\_\_  
Voltage \_\_\_\_\_  
Purchase Date \_\_\_\_\_

### Authorized Service Agent Listing

Reference the listing provided with the unit

OR

for an updated listing go to:

**Website:** [www.star-mfg.com](http://www.star-mfg.com)  
**E-mail** [Service@star-mfg.com](mailto:Service@star-mfg.com)

### Service Help Desk

**Business Hours:** 8:00 am to 4:30 p.m. Central Standard Time

**Telephone:** (314) 678-6303

**Fax:** (314) 781-2714

**E-mail** [Parts@star-mfg.com](mailto:Parts@star-mfg.com)  
[Service@star-mfg.com](mailto:Service@star-mfg.com)  
[Warranty@star-mfg.com](mailto:Warranty@star-mfg.com)

**Website:** [www.star-mfg.com](http://www.star-mfg.com)

**Mailing Address:** Star International Holdings Inc., Company  
10 Sunnen Drive  
St. Louis, MO 63143  
U.S.A

## GENERAL INSTALLATION DATA



### CAUTION

This equipment is designed and sold for commercial use only by personnel trained and experienced in its operation and is not sold for consumer use in and around the home nor for use directly by the general public in food service locations.

Before using your new equipment, read and understand all the instructions & labels associated with the unit prior to putting it into operation. Make sure all people associated with its use understand the units operation & safety before they use the unit.

All shipping containers should be checked for freight damage both visible and concealed. This unit has been tested and carefully packaged to insure delivery of your unit in perfect condition. If equipment is received in damaged condition, either apparent or concealed, a claim must be made with the delivering carrier.

Concealed damage or loss - if damage or loss is not apparent until after equipment is unpacked, a request for inspection of concealed damage must be made with carrier within 15 days. Be certain to retain all contents plus external and internal packaging materials for inspection. The carrier will make an inspection and will supply necessary claim forms.

## INSPECTION & ASSEMBLY

### UNCRATING AND INSPECTING

Unpack the unit and components from the shipping container. Remove all visible packing material and those from inside the cooking chamber. If damage is discovered, file a claim immediately with the carrier that handled the shipment. Do not operate the unit if it was damaged during shipping.

### ASSEMBLY AND INSTALLATION

The unit was shipped fully assembled and ready to plug into a standard outlet specified for its voltage and amp draw. If improper electrical supply is determined, contact a qualified electrician prior to using the unit. Removal and replacement of the power cord and plug will void the warranty. For assistance, contact your local authorized service agent for service or required maintenance.

Level unit using the adjustable feet under the unit (approximately 1/2" adjustment).

Before using the unit for the first time, wipe down the exterior with a damp cloth.



### CAUTION

Allow enough space around the toaster for adequate ventilation. Do not operate the unit without the crumb tray properly positioned. Overheating and poor toasting may occur. Read all labels on the unit and follow their instructions.

## ELECTRICAL CONNECTION



### WARNING

Before making any electrical connection to this unit, check that the power supply is adequate for the voltage, amperage and requirements stated on the rating plate. A wiring diagram is included herewith.

Disconnect the unit from the power source before installing or removing any parts.

Be absolutely sure that the ground connection for the receptacle is properly wired. Do not connect equipment to power without proper ground connections. Improper grounding may result in personal injury or fatality.



## **WARNING**

**DO NOT CUT OR REMOVE THIS PLUG OR GROUNDING PRONG FROM THE PLUG.**



## **WARNING**

**CONNECT/PLUG UNIT INTO DEDICATED A.C. LINE ONLY SPECIFIED ON THE DATA PLATE OF THE UNIT.**

## **DAILY OPERATION**

### **ROTARY POWER SAVER SWITCH**

For toasters equipped with a Rotary Power Saver Switch, turn clockwise or counterclockwise to get in the following positions.

#### **FULL POWER**

When in this position your equipment is at full power and ready to use.

#### **OFF ROTARY**

Two off positions are provided, a single rotation to either direction will shut the unit off.

#### **STANDBY**

The standby position reduces the power consumption by 75%. Using this position during the quiet times will save electricity, and keep the toaster warm. When needed, turn the switch to FULL POWER. Recovery time is about 30 seconds.



## **CAUTION**

**CERTAIN SURFACES ARE EXTREMELY HOT DURING OPERATION AND CARE SHOULD BE TAKEN WHILE USING THIS UNIT.**

## **COOKING PROCEDURES**

### **BREAD TOASTING**

Some toasters are equipped with a swinging heat shutter at the toaster entrance. This shutter will move out of the way as the product passes under it.

- 1) Turn the power saver to FULL POWER.
  - 2) Set the conveyor speed to HIGH.
  - 3) If your toaster is equipped with separate top and bottom heat controls set them both at HIGH.
  - 4) Allow warm up time of 5 to 10 minutes.
  - 5) Place a sample product on the conveyor belt to test the settings.
- If toasting is too light, turn conveyor speed control counterclockwise to a slower speed.
  - If toasting is too dark, turn heat control to a lower heat.

**(NOTE: Some products may require adjustment of the top and bottom heat controls in order to achieve the desired results)**

## TOASTER COMPONENTS

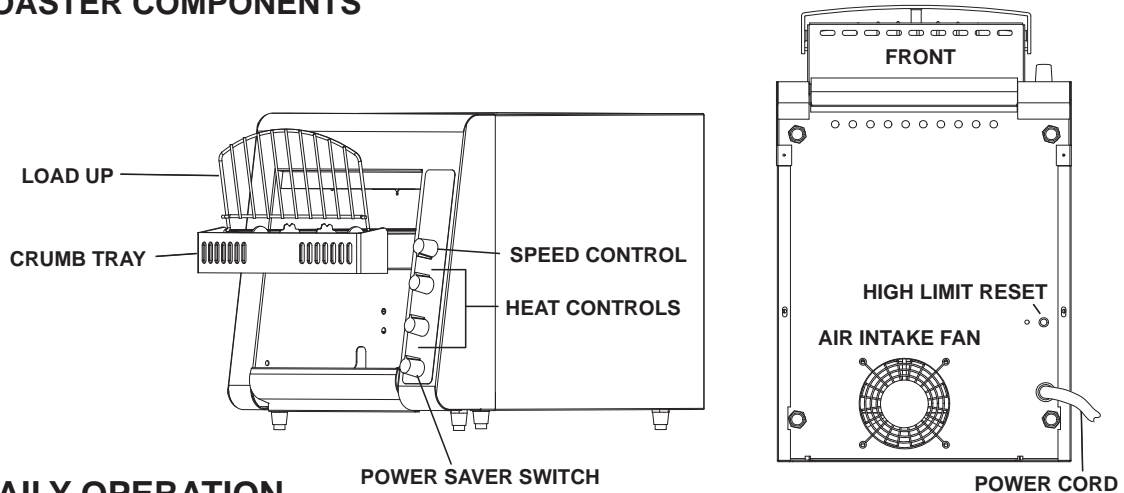

## DAILY OPERATION

Check the power cord to insure that it is plugged into a proper outlet.

Set the heat control knobs to desired temperature.

Always allow 10 minutes of preheat time before loading the unit with product. Failure to allow sufficient preheat time will result in unsatisfactory cooking until the unit reaches operating temperature.



## OPERATING HINTS AND SAFETY

Disconnect power to the unit with the switch at the end of each day of operation.

Do not leave the unit in operation without an attendant.

Turn Power Saver Switch to Standby during idle periods. It will take only a few minutes to regain operating temperature.

Do not leave the unit at high temperature when not in use or during idle periods. This will cause food particles and grease film to carbonize.

## CLEANING

Preventive maintenance for your Holman toaster consists of the following recommended cleaning procedures. To keep your toaster in its top operating condition, these steps should be performed on a daily or weekly as indicated.

- A. Clean air intake on bottom of unit.
- B. For lightly soiled conveyor belts, turn conveyor speed control to fastest setting (100) and wipe with a damp cloth (daily) For heavily soiled conveyors, turn conveyor speed control to fastest setting and wipe with a light abrasive pad (as needed).
- C. Turn main power saver switch to the OFF position. Disconnect unit from power source.
- D. After the unit cools, remove interior crumb tray (as shown below) and clean. Slide crumb tray back into position.
- E. Wipe exterior surface of unit.



## WARNING

**DO NOT IMMERSE OR LET THE UNIT STAND IN WATER.**

**DO NOT HOSE DOWN THE UNIT OR THE TABLE/COUNTER IF THE UNIT IS ON THE TABLE/COUNTER.**

**KEEP AWAY FROM RUNNING WATER.**

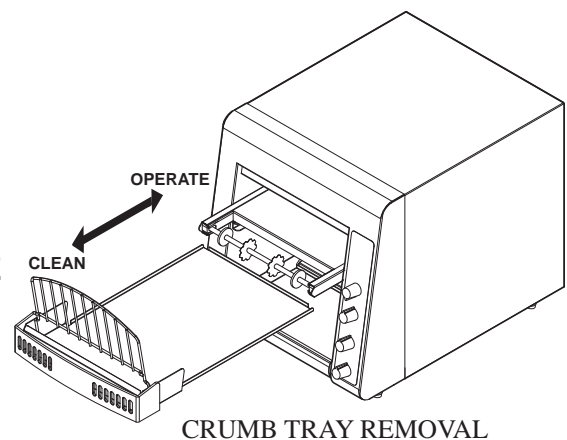

## MAINTENANCE PROCEDURES

### A. REPLACING HEATER TUBES

- 1) **DISCONNECT UNIT FROM POWER SOURCE.**
- 2) Remove the enclosure.
- 3) Remove heater tube wire from terminal block connection, keeping top and bottom wires separate.
- 4) Lift heater tube retainers by loosening retaining screws and sliding the retainer plate up. Hand tighten the plate to hold it up so the heater tubes will slide out freely.
- 5) Gently, pull defective heater tube out of unit.
- 6) Gently, put new heater tube into unit.
- 7) Loosen retainer screws and slide the retainer back into place. Tighten the screw to secure the retainer in place over the ends of the heater tubes.

### B. REPLACING FAN MOTOR

- 1) **DISCONNECT UNIT FROM POWER SOURCE.**
- 2) Remove screws from the enclosure and the back panel at rear of unit.
- 3) Remove the enclosure and the back panel.
- 4) Unplug power supply cord from fan motor.
- 5) Remove (4) screws, which hold fan motor and grill to bottom of unit and remove fan.
- 6) Put replacement motor and grill in place and secure to the bottom of unit with screws.
- 7) Reconnect power supply cord to fan motor.
- 8) Replace back panel and enclosure. Fasten with screws removed in step 2.

### C. REPLACING BELT DRIVE MOTOR

- 1) **DISCONNECT UNIT FROM POWER SOURCE.**
- 2) Remove enclosure and back panel.
- 3) Remove sprocket from motor shaft, using an Allen wrench and loosening the set-screw.
- 4) Remove the wire from terminal block connecting the drive motor to internal wiring.  
On units rated 208 or 240 volts, note which color leads are being used for these connections and which lead is capped with white tape. The new motor should use the same arrangement.
- 5) Remove screws holding motor in place and remove motor from unit.
- 6) Put new motor in place and attach loosely with mounting screws.
- 7) Replace sprocket on motor shaft.

**NOTE: The two sprockets should line up parallel with each other, so the chain does not twist any during operation. Also the hub gets installed closets to the motor.**

- 8) Slide motor until the drive chain has about 1/4" slack when lightly pushed at the center of its top open run. *See chain tensioning illustration.*
- 9) Tighten screws to secure motor.
- 10) Rewire leads same as removed in step 4.
- 11) Replace side panel and control box cover.

### D. CLEANING AIR INTAKE ONCE A WEEK

- 1) **DISCONNECT UNIT FROM POWER SOURCE.**
- 2) Place unit on its backside.
- 3) Use a vacuum cleaner and or a damp cloth to clean the air intake. This procedure should be done at least

### E. LUBRICATE THE CHAIN & SPROCKETS EVERY 6 MONTHS

- 1) **DISCONNECT UNIT FROM POWER SOURCE.**
- 2) Remove enclosure exposing chain drive.
- 3) Using an extreme pressure, synthetic chain lubricant with a temperature range up to 400°F. Apply liberally onto chain and sprockets. This grease is available as part no. **1L-Z12397.**
- 4) Replace enclosure, Reconnect power source and test unit.

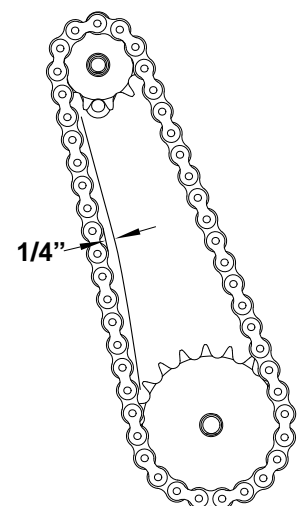

QCS/RCS Chain Tension

## **TROUBLESHOOTING GUIDE**

### **A. UNIT WILL NOT HEAT, CONVEYOR BELT WILL NOT MOVE.**

- 1) Be sure the main circuit breaker is switched to the ON position.
- 2) Check to see if the toaster is plugged in and all controls are turned to the ON position.

### **B. UNIT HAS HEAT ONLY ON ONE SIDE, CONVEYOR BELT TURNS FREELY.**

- 1) Call the Star Service Help Desk at 314-678-6303, as heating element may need replacing.

### **C. CONVEYOR WILL NOT TURN, UNIT HEATS PROPERLY.**

To check for mechanical binding:

- 1) **DISCONNECT UNIT FROM POWER SOURCE.**
- 2) Remove 2 screws holding enclosure to the bottom of the unit.
- 3) Set unit on the legs and remove 4 screws on the back of the toaster.
- 4) Slide the enclosure off the unit and remove the back panel.
- 5) Loosen the four screws that hold the drive motor in place.
- 6) Slide the motor up allowing the drive chain to be removed from the sprockets.
- 7) Move the conveyor belt by hand to check for mechanical binding. If conveyor moves freely, call the Star Service Help Desk at 314-678-6303, as the drive motor and/or speed control may need replacing.
- 8) Replace the enclosure by sliding it forward towards the front of the unit.  
The front edge of the enclosure will slide beneath the toaster front.

### **D. HEAT LIMIT SWITCH (RESET)**

Your Holman conveyor toaster is equipped with an automatically activated heat limit switch that interrupts the heater tube connections if the ambient temperature in the control box exceeds 190°F (88C). This switch can be reset manually by pushing the red button under the toaster as shown in the Toaster Components Illustration on Page 5.

- 1) **DISCONNECT UNIT FROM POWER SOURCE.**
- 2) Check to see if air intake area in the bottom center of the control box cover is free of dust, grease or other obstructions.
- 3) Check if crumb tray is in place. **NEVER OPERATE UNIT WITHOUT CRUMB TRAY IN PLACE AS THIS CAUSES OVERHEATING IN THE CONTROL BOX.**
- 4) If no obstructions to the airflow can be found and if the crumb tray is in place, call the Star Service Help Desk at 314-678-6303 for assistance.

### **E. CONVEYOR TURNS AT ONE SPEED REGARDLESS OF SPEED CONTROL SETTING.**

- 1) Call the Star Service Help Desk at 314-678-6303, as speed control should be replaced.

### **F. PRODUCT STICKING TO CONVEYOR OR SLIDE**

Your Holman conveyor toaster is designed to toast product that is a current room temperature. **DO NOT** attempt to put frozen, refrigerated, or any butter or a butter substitute material in the toaster. Doing so may cause it to come out doughy or very moist, as well as possibly sticking to parts of the unit.

- 1) Follow the cleaning procedures listed on page 5.

### THOROUGHLY INSPECT YOUR UNIT ON ARRIVAL

This unit has been tested for proper operation before leaving our plant to insure delivery of your unit in perfect condition. However, there are instances in which the unit may be damaged in transit. In the event you discover any type of damage to your product upon receipt, you must immediately contact the transportation company who delivered the item to you and initiate your claim with same. If this procedure is not followed, it may affect the warranty status of the unit.

### LIMITED EQUIPMENT WARRANTY

All workmanship and material in Star products have a one (1) year limited warranty on parts & labor in the United States and Canada. Such warranty is limited to the original purchaser only and shall be effective from the date the equipment is placed in service. Star's obligation under this warranty is limited to the repair of defects without charge, by the factory authorized service agency or one of its sub-agencies. Models that are considered portable (*see below*) should be taken to the closest Star service agency, transportation prepaid.

- > Star will not assume any responsibility for loss of revenue.
- > On all shipments outside the United States and Canada, see International Warranty.
- \* The warranty period for the JetStar six (6) ounce & Super JetStar eight (8) ounce series popcorn machines is two (2) years.
- \* The warranty period for the Chrome-Max Griddles is five (5) years on the griddle surface. See detailed warranty provided with unit.
- \* The warranty period for Teflon/Dura-Tec coatings is one year under normal use and reasonable care. This warranty does not apply if damage occurs to Teflon/Dura-Tec coatings from improper cleaning, maintenance, use of metallic utensils, or abrasive cleaners, abrasive pads, product identifiers and point-of-sale attachments, or any other non-food object that comes in continuous contact with the roller coating. This warranty does not apply to the "non-stick" properties of such materials.
- > This warranty does not apply to "Special Products" but to regular catalog items only. Star's warranty on "Special Products" is six (6) months on parts and ninety (90) days on labor.
- > This warranty does not apply to any item that is disassembled or tampered with for any purpose other than repair by a Star Authorized Service Center or the Service Center's sub-agency.
- > This warranty does not apply if damage occurs from improper installation, misuse, wrong voltage, wrong gas or operated contrary to the Installation and Operating instructions.
- > This warranty is not valid on Conveyor Ovens *unless* a "start-up/check-out" has been performed by a Factory Authorized Technician.

### PARTS WARRANTY

Parts that are sold to repair out of warranty equipment are warranted for ninety (90) days. The part only is warranted. Labor to replace the part is chargeable to the customer.

### SERVICES NOT COVERED BY WARRANTY

1. Travel time and mileage rendered beyond the 50 mile radius limit
2. Mileage and travel time on portable equipment (*see below*)
3. Labor to replace such items that can be replaced easily during a daily cleaning routine, i.e; removable kettles on fryers, knobs, grease drawers on griddles, etc.
4. Installation of equipment
5. Damages due to improper installation
6. Damages from abuse or misuse
7. Operated contrary to the Operating and Installation Instructions
8. Cleaning of equipment
9. Seasoning of griddle plates
10. Voltage conversions
11. Gas conversions
12. Pilot light adjustment
13. Miscellaneous adjustments
14. Thermostat calibration and by-pass adjustment
15. Resetting of circuit breakers or safety controls or reset buttons
16. Replacement of bulbs
17. Replacement of fuses
18. Repair of damage created during transit, delivery, & installation OR created by acts of God

### PORTABLE EQUIPMENT

Star will not honor service bills that include travel time and mileage charges for servicing any products considered "Portable" including items listed below. These products should be taken to the Service Agency for repair:

- \* The Model 510FD Fryer.
- \* The Model 526TOA Toaster Oven.
- \* The Model J4R, 4 oz. Popcorn Machine.
- \* The Model 518CMA & 526CMA Cheese Melter.
- \* The Model 12MC & 15MC & 18MCP Hot Food Merchandisers.
- \* The Model 12NCPW & 15NCPW Nacho Chip/Popcorn Warmer.
- \* All Hot Dog Equipment **except Roller Grills & Drawer Bun Warmers.**
- \* All Nacho Cheese Warmers **except Model 11WLA Series Nacho Cheese Warmer.**
- \* All Condiment Dispensers **except the Model HPD & SPD Series Dispenser.**
- \* All Specialty Food Warmers **except Model 130R, 11RW Series, and 11WSA Series.**
- \* All QCS/RCS Series Toasters **except Model QCS3 & RCS3 Series.**
- \* All Fast Steamer Models **except Direct Connect Series.**

### ALL:

- \* Pop-Up Toasters
- \* Butter Dispensers
- \* Pretzel Merchandisers  
(Model 16PD-A Only)
- \* Pastry Display Cabinets
- \* Nacho Chip Merchandisers
- \* Accessories of any kind
- \* Sneeze Guards
- \* Pizza Ovens  
(Model PO12 Only)
- \* Heat Lamps
- \* Pumps-Manual

The foregoing warranty is in lieu of any and all other warranties expressed or implied and constitutes the entire warranty.

### FOR ASSISTANCE

Should you need any assistance regarding the Operation or Maintenance of any Star equipment; write, phone, fax or email our Service Department. In all correspondence mention the Model number and the Serial number of your unit, and the voltage or type of gas you are using.



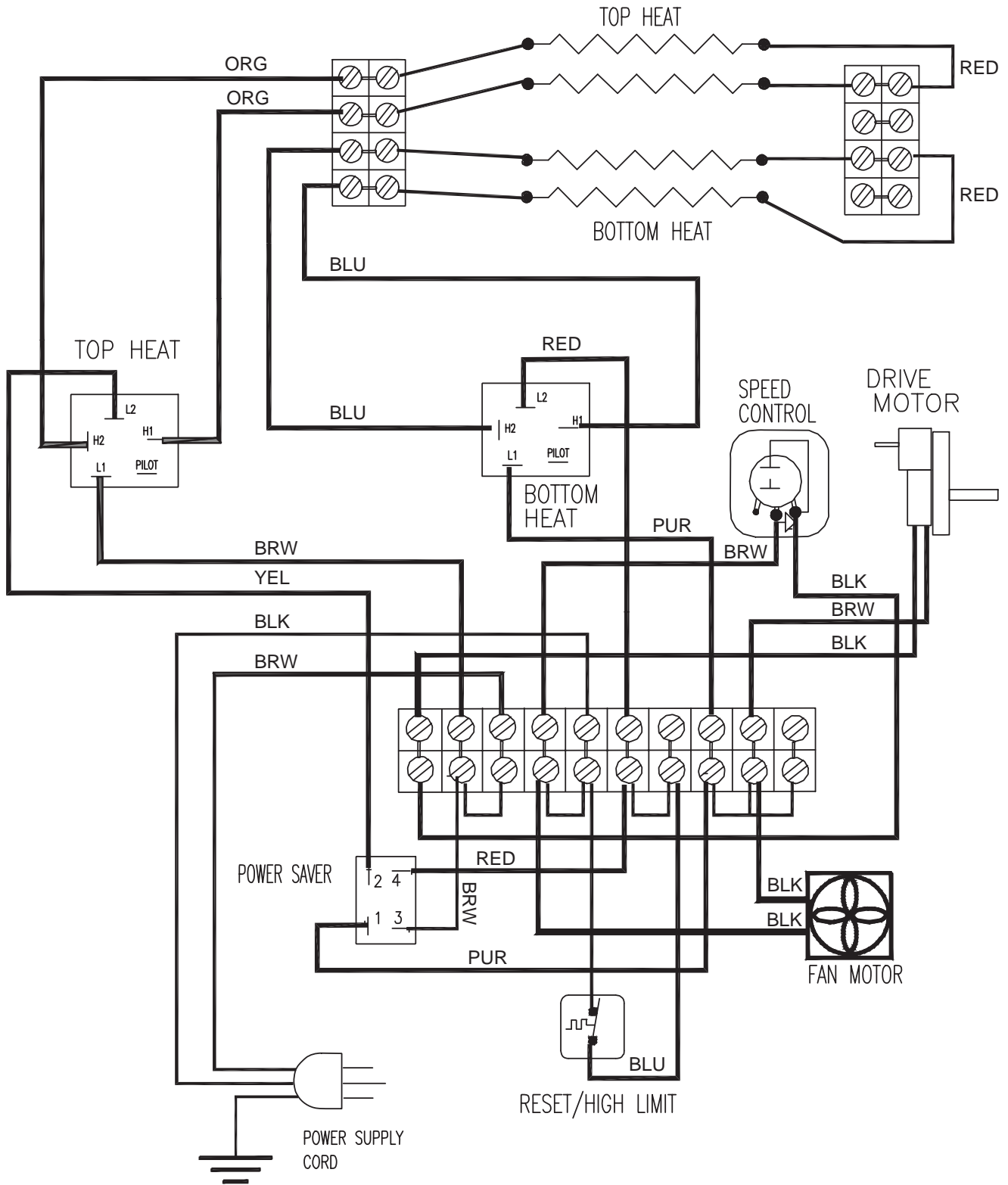

THIS DRAWING CONTAINS INFORMATION CONFIDENTIAL TO STAR MFG. INT'L. INC.  
 NO REPRODUCTION OR DISCLOSURE OF ITS CONTENTS IS PERMITTED.



**MODEL: QCS & RCS 4 TUBE - SERIES**

**STAR MANUFACTURING INTERNATIONAL INC.**

065264

Rev A

04/16/2001

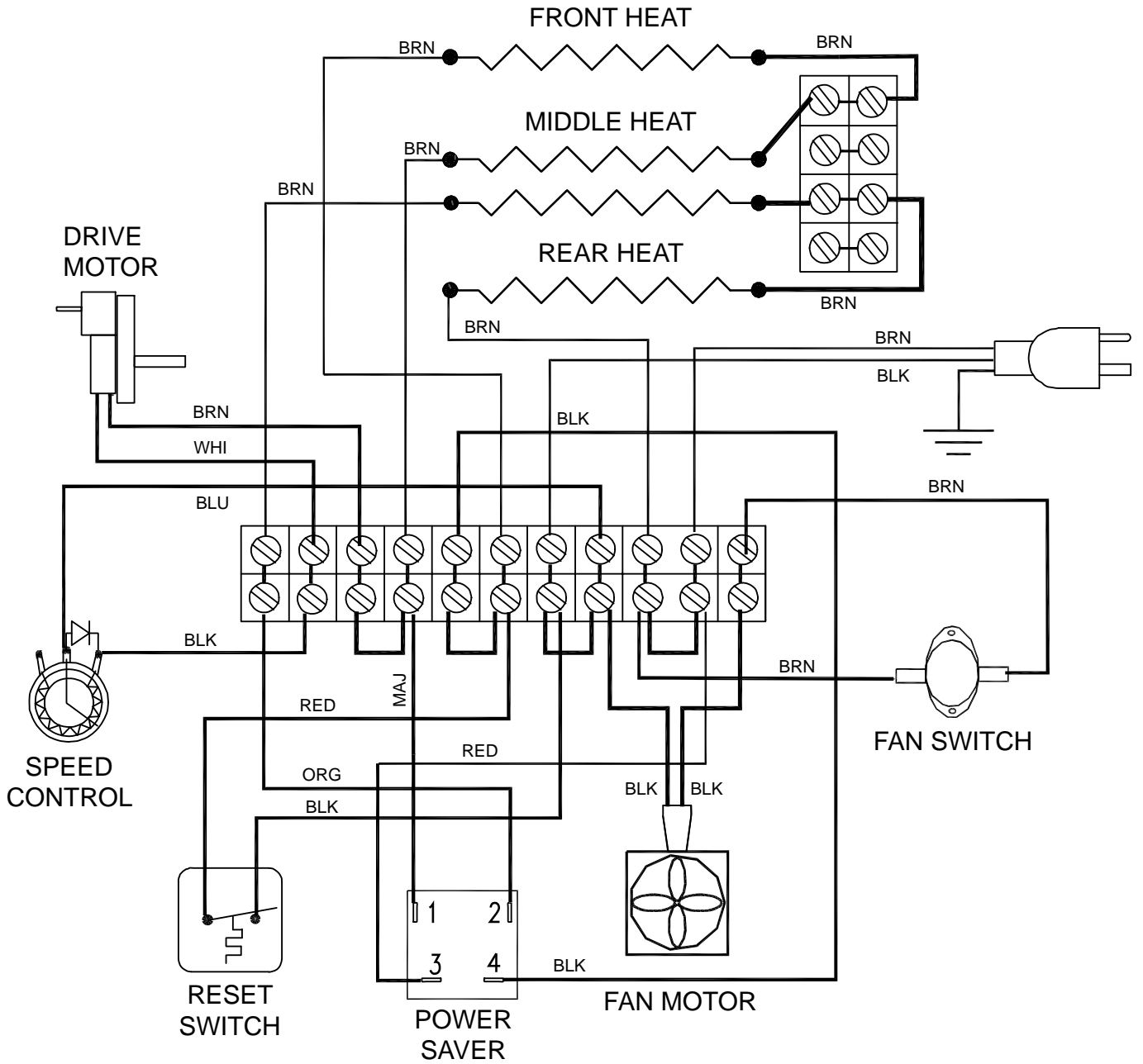

**NOTE: DRIVE MOTOR, FOR 240V USE BLACK AND BLUE WIRES,  
FOR 208V USE BLACK & WHITE WIRES.**

THIS DRAWING CONTAINS INFORMATION CONFIDENTIAL TO STAR MFG. INT'L. INC.  
NO REPRODUCTION OR DISCLOSURE OF ITS CONTENTS IS PERMITTED.

**MODEL: QCS-2-1200B, QCS3-95HNN, QCS-3-1600B**



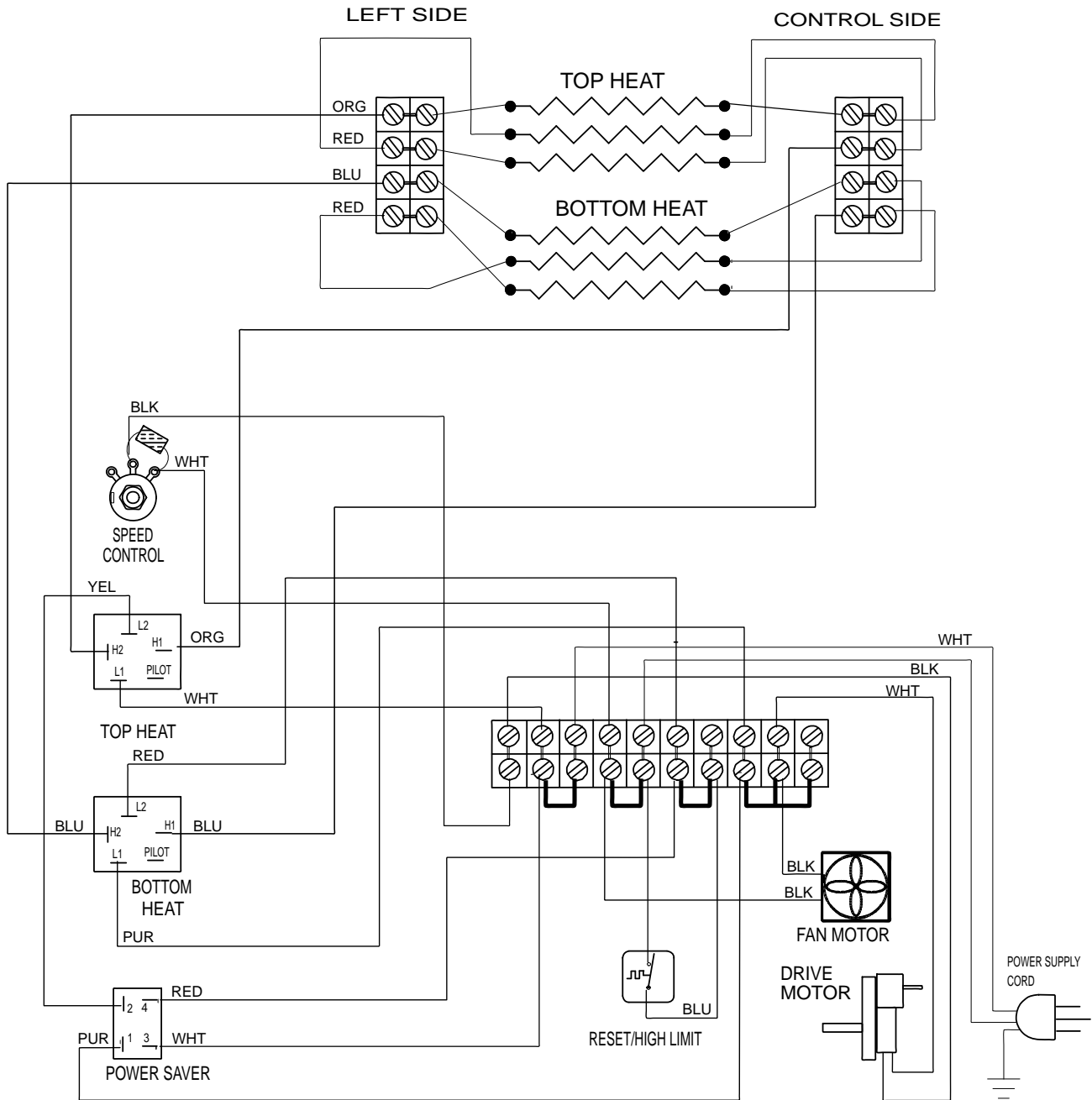

**MODELS:**

- QCS2-600, 800, 208/220/240V, 50-60Hz, 6 Tube, Phase Control, wired Series
- QCS3-950, 1000, 1300, 208/220/240V, 50-60Hz, 6 Tube, Phase Control, wired Series
- Q3-95ARB, 208/220/240V, 50-60Hz, 6 Tube, Phase Control, wired Series



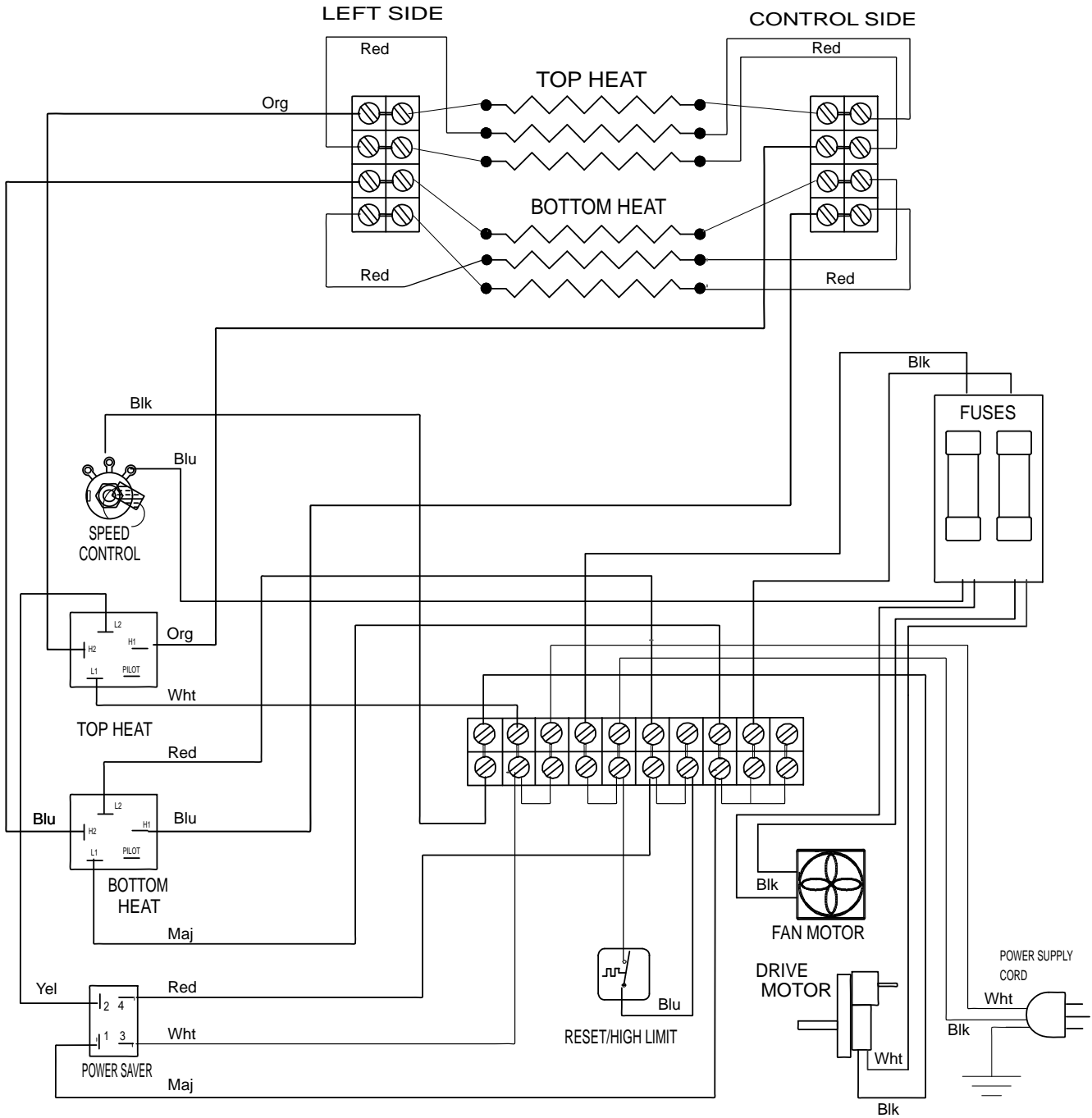

**MODEL: QCS-3-1300 208/220/240V w/FUSE**  
**Q3-95ARB 208/240 w/FUSE**

THIS DRAWING CONTAINS INFORMATION CONFIDENTIAL TO STAR MFG. INT'L. INC.  
 NO REPRODUCTION OR DISCLOSURE OF ITS CONTENTS IS PERMITTED.



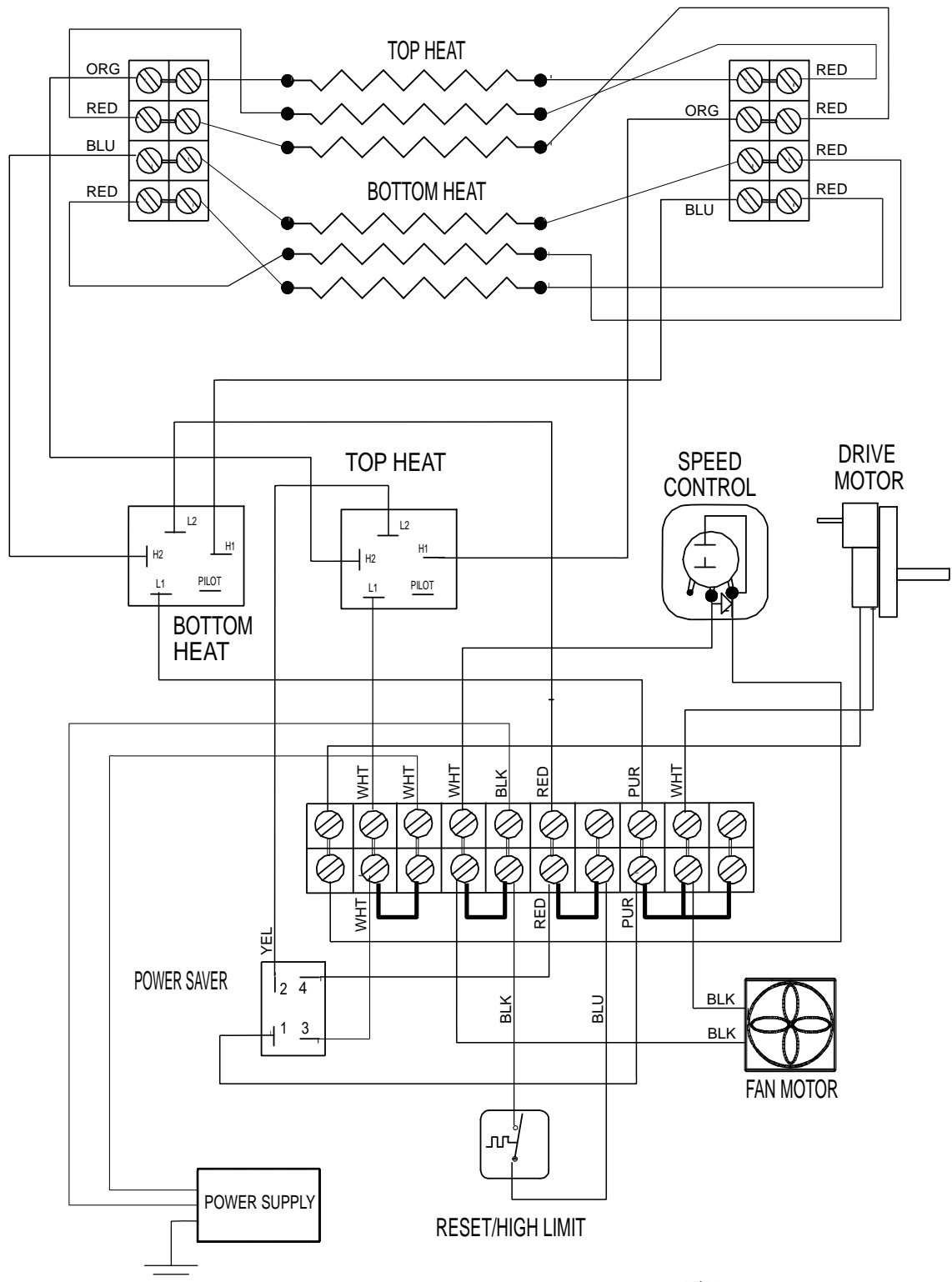

**MODELS:**

QCS2-600, 800, 220/240V, 50Hz, 6 Tube, Phase Control, wired Series, CE  
 QCS3-950, 1000 220/240V, 50-60Hz, 6 Tube, Phase Control, wired Series, CE



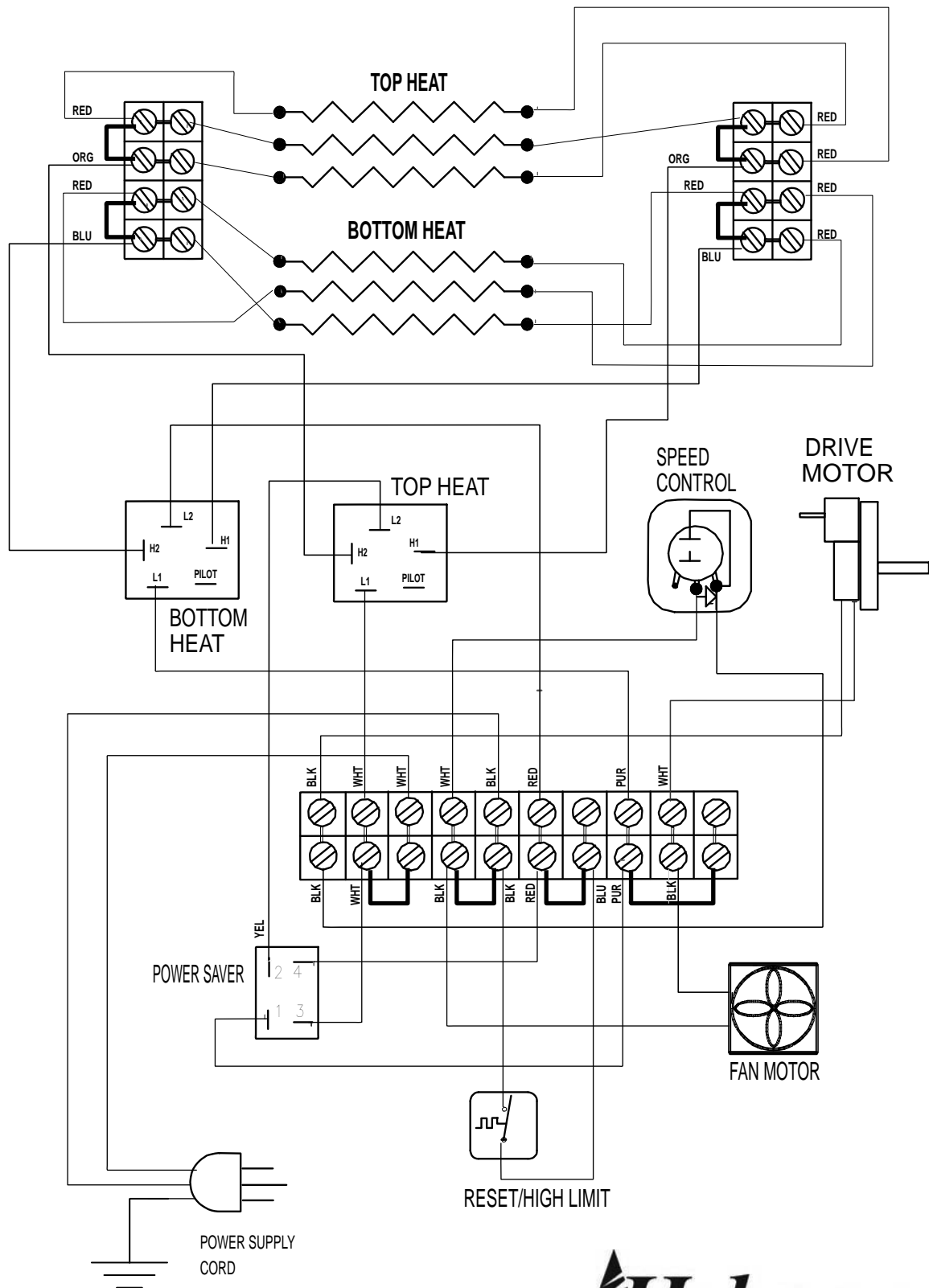

**MODELS:**  
 QCS2-300, 500, 50-60Hz, 6 Tube, Phase Control, wired Parallel



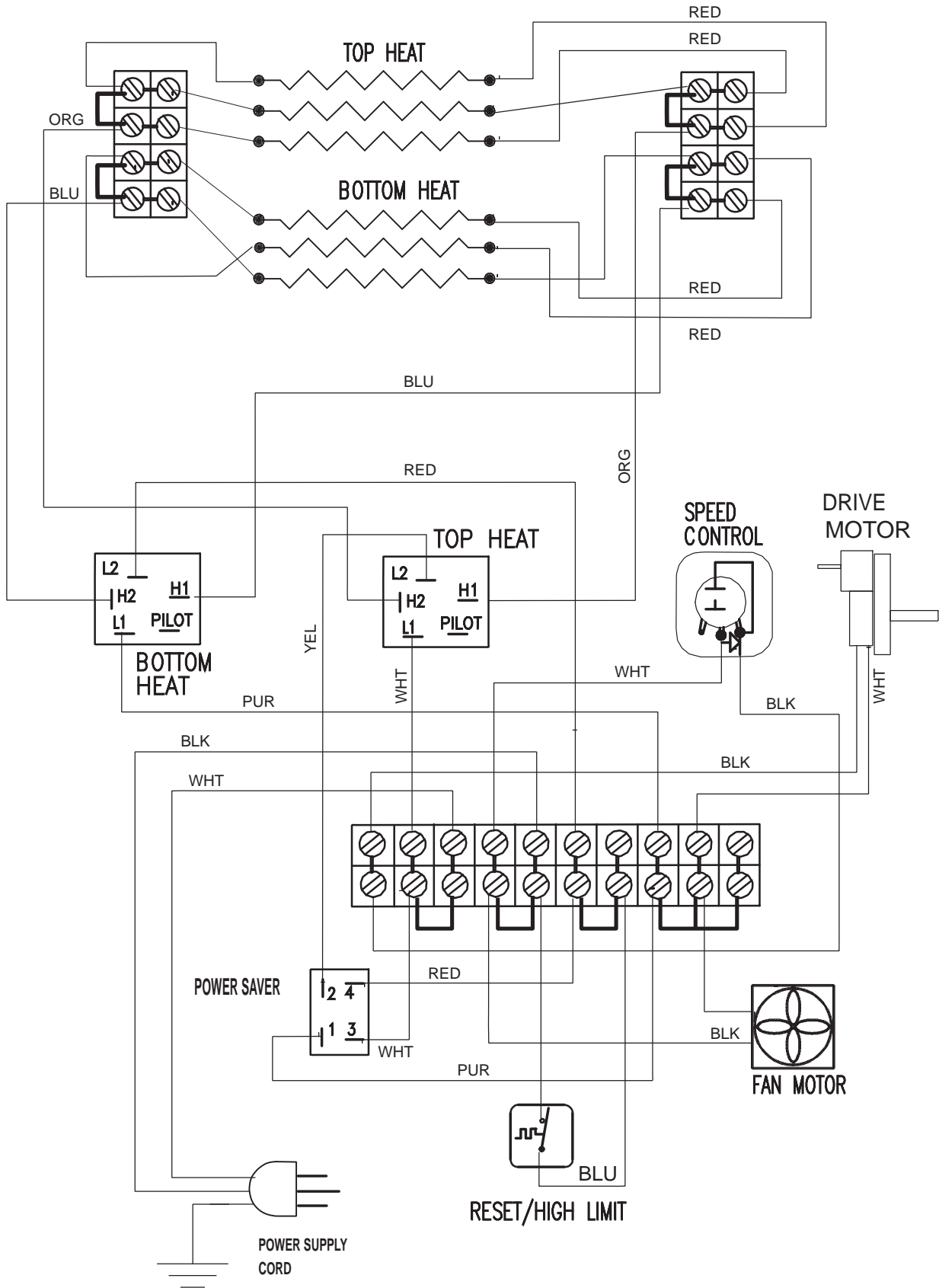

**MODEL: QCS-RCS 14", 120/208/240V - 6 Tube - Wired Parallel**

THIS DRAWING CONTAINS INFORMATION CONFIDENTIAL TO STAR MFG. INT'L. INC.  
 NO REPRODUCTION OR DISCLOSURE OF ITS CONTENTS IS PERMITTED.



**STAR MANUFACTURING INTERNATIONAL INC.**

065606

Rev B

12/11/2003

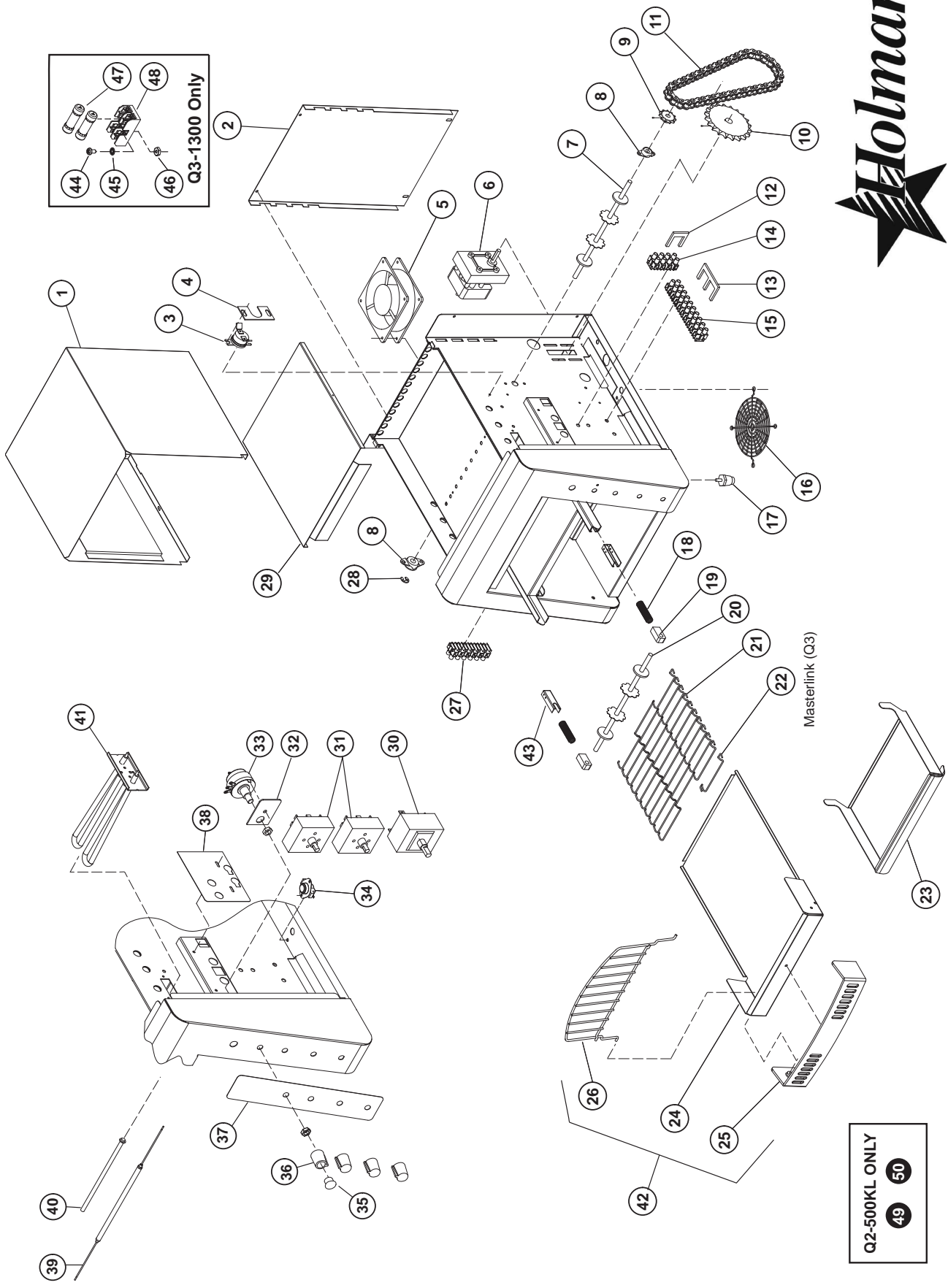

44 45 46 47 48  
**Q3-1300 Only**

**Q2-500KL ONLY**  
 49 50

Masterlink (Q3)

**MODEL: QCS/RCS CONVEYOR TOASTER**

THIS DRAWING CONTAINS INFORMATION CONFIDENTIAL TO STAR MFG. INT'L. INC.  
 NO REPRODUCTION OR DISCLOSURE OF ITS CONTENTS IS PERMITTED.



# PARTS LIST

February 6, 2012, Rev. J

## QCS-2-300H, QCS-2-500, RCS-2-500 Conveyor Toasters

Key Number	Part Number	Number Per Unit	Description & Model
1	HC-101370	1	ENCLOSURE, QCS2/RCS
2	HF-402449	1	PANEL, BACK, QCS2/RCS
5	2U-200559	1	MOTOR, FAN
6	2U-Z13803	1	MOTOR, DRIVE, FAN BLADE INCLUDED
	2R-Z8879	1	FAN BLADE, MOTOR
7	2A-202900	1	SHAFT, DRIVE
8	HA-112261	2	BUSHING, REAR
9	2P-Z8779	1	SPROCKET, DRIVEN (25B11 X 5/16")
10	2P-200645	1	SPROCKET, DRIVE (25B17 X 5/16")
11	2P-150013	1	CHAIN, DRIVE (19")
12	2P-115501	7	JUMPER, TWO POSITION, SMALL
13	2P-115502	1	JUMPER, THREE POSITION, SMALL
14	HC-115381	1	BLOCK, TERMINAL, SMALL, 4 POS.
15	H9-Z10282	1	BLOCK, TERMINAL, SMALL, 10 POS.
16	2R-200562	1	GUARD, FAN
17	2R-200709	4	LEG, 1" CHROME PLASTIC
18	2P-200736	2	SPRING, BUSHING, FRONT
19	2P-200700	2	BUSHING, FRONT
20	2A-202904	1	SHAFT, IDLER
21	SP-160027	1	CONVEYOR BELT (10" X 35 - 1/2")
	2B-200601	AR	INDIVIDUAL BELT LINK
23	HA-100560	1	TRAY, PULL-OUT
24	HC-402457	1	TRAY, CRUMB
25	2R-200787	1	GUARD, CRUMB TRAY
26	2B-200763	1	WIRE RACK, LOAD-UP
27	HQ-135553	1	WIRING HARNESS, BF700 RCS
28	2A-200284	1	E-CLIP
29	HC-100570	1	BAFFLE, AIR FLOW HI QCS-2-300
	HD-100571	1	BAFFLE, AIR FLOW LOW QCS/RCS-2-500
30	2E-200551	1	SWITCH, ROTARY POWER SAVER
31	2J-200539	2	SWITCH, INFINITE
32	2P-402728	1	ANTI-SPIN PLATE
33	SP-118002	1	SWITCH, SPEED CONTROL (250W)
34	2E-200566	1	SWITCH, HIGH LIMIT RESET
35	2R-200708	4	CAP, KNOB
36	2R-200768	3	KNOB, SPEED CONTROL & INFINITE SWITCH
	2R-200768	1	KNOB, POWER SAVER (manufactured before 11/2001)
	2R-200769	1	KNOB, POWER SAVER (manufactured after 11/2001)
37	2M-200864	1	LABEL, CONTROL PANEL QCS
	2M-200899	1	LABEL, CONTROL PANEL RCS
38	HC-402499	1	RETAINER, ELEMENT
	HE-402544	1	RETAINER, ELEMENT RCS
39	HD-198042	6	HEATER TUBE, QUARTS 120V (49.33 $\Omega$ , 275W, 2.26A) (UNIT = 14.3 A)
40	SEE TABLE		ELEMENT, METAL RCS
41	SEE TABLE		ELEMENT, SERPENTINE RCS
42	HF-101115	1	TRAY, CRUMB ASSEMBLY, QCS/RCS - 2
43	2A-Z9394	2	SPRING BEARING HOUSING
49	HB-Z11456	1	SECURITY LOCKING COVER Q2-500KL-120
50	2R-200752	1	KEYLOCK SPEC KEYED ALIKE Q2-500KL-120
NI	2B-200600	1	LINK, CONVEYOR BELT
NI	HA-140026	1	CORD, POWER, NEMA 5-15 (-V01)
NI	HO-140046	1	CORD, POWER, NEMA 5-20 (-V61) (CANADA)
NI	2E-200387	1	CORD, FAN MOTOR
NI	2R-200721	1	BLADE, FAN 2-5/16" (drive motor)
NI	2K-200465	1	CORD BUSHING
NI	1L-Z12397	AR	EXTREME PRESSURE MULTIPURPOSE SYNTHETIC GREASE (80°F TO 400°F) , TUBE 1 oz.

**IMPORTANT: WHEN ORDERING, SPECIFY VOLTAGE OR TYPE GAS DESIRED  
INCLUDE MODEL AND SERIAL NUMBER**

PAGE 1  
OF 1

Some items are included for illustrative purposes only and in certain instances may not be available.



# PARTS LIST

February 6, 2012, Rev. J

## QCS-2-600H, QCS-2-800, RCS-2-600 Conveyor Toasters

Key Number	Part Number	Number Per Unit	Description
1	HC-101370	1	ENCLOSURE, QCS/RCS-2
2	HF-402449	1	PANEL, BACK, QCS/RCS-2
5	2U-200560	1	MOTOR, FAN
6	2U-200509	1	MOTOR, DRIVE, FAN BLADE NOT INCLUDED
	2U-200590	1	MOTOR,DRIVE,3286 BB,LOW, FAN BLADE NOT INCLUDED 50Hz CE
	2R-Z8879	1	FAN BLADE, MOTOR
7	2A-202900	1	SHAFT, DRIVE
8	HA-112261	2	BUSHING, REAR
9	2P-Z8779	1	SPROCKET, DRIVEN (25B11 X 5/16")
10	2P-200645	1	SPROCKET, DRIVE (25B17 X 5/16")
11	2P-150013	1	CHAIN, DRIVE (19")
12	2P-115501	3	JUMPER, TERMINAL BLOCK, SMALL, 2 POS.
13	2P-115502	1	JUMPER, TERMINAL BLOCK, SMALL, 3 POS.
14	HC-115381	2	BLOCK, TERMINAL, SMALL, 4 POS.
15	H9-Z10282	1	BLOCK, TERMINAL, SMALL, 10 POS.
16	2R-200562	1	GUARD, FAN MOTOR
17	2R-200709	4	LEG, 1" CHROME PLASTIC
18	2P-200736	2	SPRING, BUSHING, FRONT
19	2P-200700	2	BUSHING, FRONT
20	2A-202904	1	SHAFT, IDLER
21	SP-160027	1	BELT, CONVEYOR (10" X 35 - 1/2")
	2B-200601	AR	INDIVIDUAL BELT LINK
23	HA-100560	1	TRAY, PULL-OUT
24	HC-402457	1	CRUMB TRAY
25	2R-200787	1	CRUMB TRAY GUARD
26	2B-200763	1	LOAD-UP WIRE RACK
28	2A-200284	1	E-CLIP
29	HC-100570	1	BAFFLE, AIR FLOW HI QCS/RCS-600
	HD-100571	1	BAFFLE, AIR FLOW LOW QCS/RCS-800
30	2E-200551	1	SWITCH, ROTARY POWER SAVER
31	2J-200538	2	SWITCH, INFINITE
32	2P-402728	1	ANTI-SPIN PLATE
33	SP-118042	1	SWITCH, SPEED CONTROL, 500 OHM
34	2E-200566	1	SWITCH, HIGH LIMIT RESET
35	2R-200708	4	CAP, KNOB
36	2R-200768	3	KNOB, SPEED CONTROL, INFINITE SWITCH
	2R-200768	1	KNOB, POWER SAVER (manufactured before 11/2001)
	2R-200769	1	KNOB, POWER SAVER (manufactured after 11/2001)
37	2M-200864	1	LABEL, CONTROL PANEL QCS
	2M-200899	1	LABEL, CONTROL PANEL RCS
38	HC-402706	1	RETAINER, ELEMENT, 4 TUBE
	HC-402499	1	RETAINER, ELEMENT, 6 TUBE
	HG-402784	1	RETAINER, ELEMENT RCS
39	HE-197829	6	HEATER TUBE, QUARTS 208V (9.7 Ω, 466W, 6.74A) (UNIT = 14 A)
	HE-198050	6	HEATER TUBE, QUARTS 220V (11.2 Ω, 450W, 6.18A) (UNIT = 13.2 A)
	HF-198051	6	HEATER TUBE, QUARTS 240V (12.6 Ω, 480W, 5.99A) (UNIT = 12.2 A)
	HO-197841	4	HEATER TUBE, QUARTS 208V (15.5 Ω, 703W) (UNIT = 13.52 A)
	HO-197844	4	HEATER TUBE, QUARTS 220V (15.84 Ω, 720W) (UNIT = 13.9A)
	HO-197842	4	HEATER TUBE, QUARTS 240V (19.2 Ω, 707W) (UNIT = 11.78 A)
40	SEE TABLE		ELEMENT, METAL RCS
41	SEE TABLE		ELEMENT, SERPENTINE RCS
42	HF-101115	1	CRUMB TRAY ASSEMBLY, QCS/RCS - 2
43	2A-Z9394	2	SPRING BEARING HOUSING
NI	2B-200600	1	LINK, CONVEYOR BELT
NI	HE-140025	1	CORD, POWER (NEMA 6-20)
NI	2E-Z7242	1	POWER CORD - UK 240V, 50Hz CE
NI	2E-200387	1	CORD, FAN MOTOR
NI	2R-200721	1	BLADE, FAN 2-5/16" (drive motor)
NI	2K-200465	1	BUSHING, CORD HEYCO
NI	2K-200463	1	BUSHING CORD HEYCO 1247
NI	2K-Y2967	1	BUSHING HEYCO 1240 BLK 240V 50Hz CE
NI	1L-Z12397	1	EXTREME PRESSURE MULTIPURPOSE SYNTHETIC GREASE (80°F TO 400°F) 1 oz. TUBE

**IMPORTANT: WHEN ORDERING, SPECIFY VOLTAGE OR TYPE GAS DESIRED  
INCLUDE MODEL AND SERIAL NUMBER**

PAGE 1  
OF 1

**Some items are included for illustrative purposes only and in certain instances may not be available.**



## QCS-3-950H, QCS-3-1000, RCS-3-950, RCS-3-1000 Conveyor Toasters

Key Number	Part Number	Number Per Unit	Description
1	HH-101371	1	ENCLOSURE, QCS3
2	HH-402470	1	PANEL, BACK, QCS3
3	2E-200574	1	SWITCH, FAN CERAMIC
4	HG-402144	1	BRACKET, FAN SWITCH
5	2U-200561	1	MOTOR, FAN
6	2U-200509	1	MOTOR, DRIVE, FAN BLADE NOT INCLUDED
	2U-200590	1	MOTOR, DRIVE, 3286 BB LOW, FAN BLADE NOT INCLUDED 240V CE
	2R-Z8879	1	FAN BLADE, MOTOR
7	2A-202902	1	SHAFT, DRIVE
8	HA-112261	2	BUSHING, REAR
9	2P-Z8779	1	SPROCKET, DRIVEN (25B11 X 5/16")
10	2P-200645	1	SPROCKET, DRIVE (25B17 X 5/16")
11	2P-150013	1	CHAIN, DRIVE (19")
12	2P-115501	3	JUMPER, TERMINAL BLOCK, SMALL, 2 POS.
13	2P-115502	1	JUMPER, TERMINAL BLOCK, SMALL, 3 POS.
14	HC-115381	2	BLOCK, TERMINAL. SMALL, 4 POS.
15	H9-Z10282	1	BLOCK, TERMINAL, SMALL, 10 POS.
16	2R-200562	1	GUARD, FAN MOTOR
17	2R-200709	4	LEG, 1" CHROME PLASTIC
18	2P-200736	2	SPRING, BUSHING, FRONT
19	2P-200700	2	BUSHING, FRONT
20	2A-202905	1	SHAFT, IDLER
21	SP-160028	1	CONVEYOR, BELT (14" X 35")
22	2B-200603	3	LINK, MASTER, CONVEYOR BELT
23	HH-100561	1	TRAY, PULL-OUT
24	HH-402465	1	TRAY, CRUMB
25	2R-200788	1	GUARD, CRUMB TRAY
26	2B-200764	1	WIRE RACK, LOAD-UP
28	2A-200284	1	E-CLIP
29	HH-100572	1	BAFFLE, AIR FLOW HI QCS/RCS-3-950
	HI-100573	1	BAFFLE, AIR FLOW LOW QCS/RCS-3-1000
30	2E-200551	1	SWITCH, ROTARY POWER SAVER
31	2J-200538	2	SWITCH, INFINITE
32	2P-402728	1	ANTI-SPIN PLATE
33	SP-118042	1	SWITCH, SPEED CONTROL, (500W)
34	2E-200566	1	SWITCH, HIGH LIMIT RESET
35	2R-200708	4	CAP, KNOB
36	2R-200768	3	KNOB, SPEED CONTROL, INFINITE SWITCH
	2R-200768	1	KNOB, POWER SAVER (before 1101)
	2R-200769	1	KNOB, POWER SAVER (after 1101)
37	2M-200864	1	LABEL, CONTROL PANEL QCS
	2M-200899	1	LABEL, CONTROL PANEL RCS
38	HC-402499	1	RETAINER, ELEMENT, 6 TUBE
	HC-402706	1	RETAINER, ELEMENT, 4 TUBE
39	HH-198053	6	HEATER TUBE QUARTS, 208V (8.4 Ω, 540W, 7.79A) (UNIT = 15.4 A)
	HI-198056	6	HEATER TUBE QUARTS, 220V (9.7 Ω, 525W, 7.13A) (UNIT = 14.9 A)
	HI-198057	6	HEATER TUBE QUARTS, 240V (11.24 Ω, 535W, 6.71A) (UNIT = 13.3 A)
	HT-197845	4	HEATER TUBE QUARTS, 208V (12.64 Ω, 807W, 7.75A) (UNIT = 15.4 A)
	HT-197846	4	HEATER TUBE QUARTS, 208V Series (905W)
	GB-197847	4	HEATER TUBE QUARTS, 240V (16.85 Ω, 806W, 6.7A) (UNIT = 13.3 A)
	GB-198111	4	HEATER TUBE QUARTS, 240V CE Q3-10A-V68
40	SEE TABLE		ELEMENT, METAL RCS
41	SEE TABLE		ELEMENT, SERPENTINE RCS
42	HI-101116	1	TRAY, CRUMB ASSEMBLY, QCS/RCS - 3
43	2A-Z9394	2	SPRING BEARING HOUSING
NI	2B-200602	1	LINK, CONVEYOR BELT
NI	2E-200372	1	CORD SET, 12/3 CORD, 6-20
NI	2E-200387	1	CORD, FAN MOTOR
NI	2R-200721	1	BLADE, FAN 2-5/16"
NI	2K-200465	1	BUSHING, CORD HEYCO
NI	2K-200463	1	BUSHING, CORD HEYCO 1247 240VCE

**IMPORTANT: WHEN ORDERING, SPECIFY VOLTAGE OR TYPE GAS DESIRED  
INCLUDE MODEL AND SERIAL NUMBER**

PAGE 1  
OF 1

Some items are included for illustrative purposes only and in certain instances may not be available.



# PARTS LIST

November 23, 2010, Rev. J

## QCS-3-1300, RCS-3-1300 Conveyor Toasters

Key Number	Part Number	Number Per Unit	Description
1	HH-101371	1	ENCLOSURE QCS/RCS-3
2	HH-402470	1	PANEL, BACK QCS/RCS-3
3	2E-200574	1	SWITCH, FAN CERAMIC
4	HG-402144	1	BRACKET, FAN SWITCH
5	2U-200561	1	MOTOR, FAN
6	2U-200509	1	MOTOR, DRIVE, FAN BLADE NOT INCLUDED
	2R-Z8879	1	FAN BLADE, MOTOR
7	2A-202902	1	SHAFT, DRIVE
8	HA-112261	2	BUSHING, REAR
9	2P-Z8779	1	SPROCKET, DRIVEN (25B11 X 5/16")
10	2P-200645	1	SPROCKET, DRIVE (25B17 X 5/16")
11	2P-150013	1	CHAIN, DRIVE (19")
12	2P-115501	3	JUMPER, TERMINAL BLOCK, SMALL, 2 POS.
13	2P-115502	1	JUMPER, TERMINAL BLOCK, SMALL, 3 POS.
14	HC-115381	2	BLOCK, TERMINAL, SMALL, 4 POS.
15	H9-Z10282	1	BLOCK, TERMINAL, SMALL, 10 POS.
16	2R-200562	1	GUARD, FAN MOTOR
17	2R-200709	4	LEG, 1" CHROME PLASTIC
18	2P-200736	2	SPRING, BUSHING, FRONT
19	2P-200700	2	BUSHING, FRONT
20	2A-202905	1	SHAFT, IDLER
21	SP-160028	1	CONVEYOR, BELT (14" X 35")
22	2B-200603	3	LINK, MASTER, CONVEYOR BELT
23	HH-100561	1	TRAY, PULL-OUT
24	HH-402465	1	TRAY, CRUMB
25	2R-200788	1	GUARD, CRUMB TRAY
26	2B-200764	1	WIRE RACK, LOAD-UP
28	2A-200284	1	E-CIIP
29	HI-100573	1	BAFFLE, AIR FLOW LOW
30	2E-200551	1	SWITCH, ROTARY POWER SAVER
31	2J-200538	2	SWITCH, INFINITE
32	2P-402728	1	ANTI-SPIN PLATE
33	SP-118042	1	SWITCH, SPEED CONTROL, (500W)
34	2E-200566	1	SWITCH, HIGH LIMIT RESET
35	2R-200708	4	CAP, KNOB
36	2R-200768	3	KNOB, SPEED CONTROL, INFINITE SWITCH
	2R-200768	1	KNOB, POWER SAVER (manufactured before 11/2001)
	2R-200769	1	KNOB, POWER SAVER (manufactured after 11/2001)
37	2M-200864	1	LABEL, CONTROL PANEL QCS
	2M-200899	1	LABEL, CONTROL PANEL, RCS
38	HC-402499	1	RETAINER, ELEMENT, 6 TUBE
	HE-402544	1	RETAINER, ELEMENT RCS
39	HJ-198060	6	HEATER TUBE QUARTS, 208V (8.4 $\Omega$ , 540W, 7.79A) (UNIT = 15.4 A)
	HH-198053	6	HEATER TUBE QUARTS, 220V (9.7 $\Omega$ , 525W, 7.13A) (UNIT = 14.9 A)
	HJ-198054	6	HEATER TUBE QUARTS, 240V (11.24 $\Omega$ , 535W, 6.71A) (UNIT = 13.3 A)
40	SEE TABLE		ELEMENT, METAL RCS
41	SEE TABLE		ELEMENT, SERPENTINE RCS
42	HI-101116	1	TRAY, CRUMB ASSEMBLY, QCS/RCS - 3
43	2A-Z9394	2	SPRING BEARING HOUSING
44	2C-1487	2	SCREW 6-32X1/4 RHP ST, FUSEHOLDER
45	2C-H8669	2	WASHER #6 INT STL NP
46	2C-2553	2	NUT 6-32 HEX STL NP
47	2E-Z5681	1	FUSEHOLDER, CLASS G
48	2E-Z5680	2	FUSE, 5A - CLASS G
NI	2B-200610	1	LINK, CONVEYOR BELT
NI	HJ-140027	1	CORD, POWER (NEMA 6-30)
NI	2E-200387	1	CORD, FAN MOTOR
NI	2R-200721	1	BLADE, FAN 2-5/16"
NI	2K-200465	1	BUSHING, CORD HEYCO
NI	1L-Z12397	1	EXTREME PRESSURE MULTIPURPOSE SYNTHETIC GREASE (80°F TO 400°F) 1 oz. TUBE



# PARTS LIST

## RCS Conveyor Toasters HEATER TUBES

Key Number	Description	Part Number	Number Per Unit
40	R2-50, 120V	2N-209100	4
	RCS-2-600H, 240V	2N-209106	4
	RCS-2-600H, 208V	2N-209197	4
	RCS-2-600HJ, 208V	2N-209199	4
	RCS-2-600HJ, 240V	2N-209216	4
	RCS-2-800, 240V	2N-209106	4
	RCS-2-800, 208V	2N-209197	4
	RCS-2-1200B, 208V	2N-209198	2
	RCS-3-950H, 208V	2N-209130	4
	RCS-3-950H, 240V	2N-209160	4
	RCS-3-1000, 208V	2N-209130	4
	RCS-3-1000, 240V	N/A	N/A
	RCS-3-1300, 208V	2N-209150	4
	RCS-3-1300, 208V	2N-209131	6
	RCS-3-1300, 240V	2N-209180	4
	RCS-3-1300, 240V	N/A	N/A
	41	9H-R2-12BSH-V02	2N-209108
9H-R2-12BA-V04		2N-209112	2
9H-R2-12BASH-V04		2N-209112	2
9H-R2-12BA-V02		2N-209114	2
9H-R2-12BASH-V02		2N-209114	2

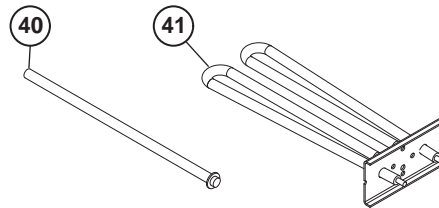

RCS HEATER TUBES