



Holman[®]

CONVEYOR TOASTER

MODEL
QCSe-2, QCSe-3 SERIES

Installation and Operation Instructions

2M-HG0653 Rev.E 4/19/2011

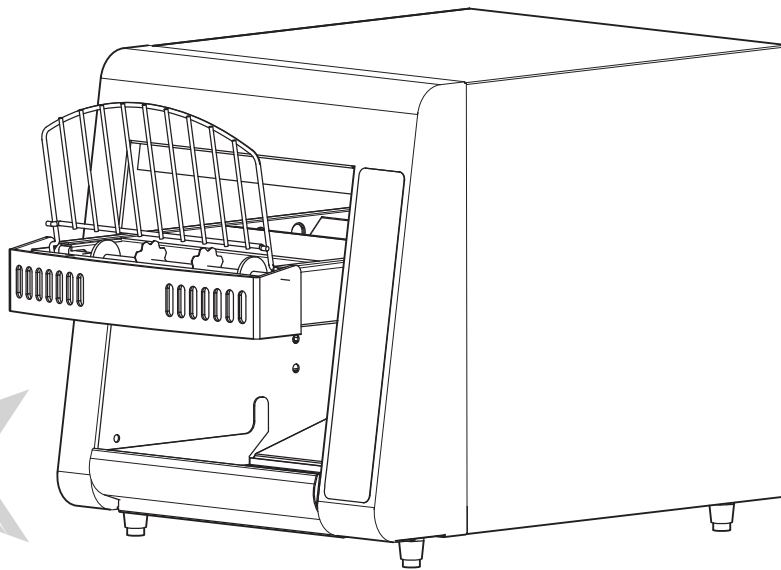

QCSe-2



SAFETY SYMBOL



These symbols are intended to alert the user to the presence of important operating and maintenance instructions in the manual accompanying the appliance.

RETAIN THIS MANUAL FOR FUTURE REFERENCE NOTICE

Using any part other than genuine Star factory supplied parts relieves the manufacturer of all liability.

Star reserves the right to change specifications and product design without notice. Such revisions do not entitle the buyer to corresponding changes, improvements, additions or replacements for previously purchased equipment.

Due to periodic changes in designs, methods, procedures, policies and regulations, the specifications contained in this sheet are subject to change without notice. While Star International Holdings Inc., Company exercises good faith efforts to provide information that is accurate, we are not responsible for errors or omissions in information provided or conclusions reached as a result of using the specifications. By using the information provided, the user assumes all risks in connection with such use.

MAINTENANCE AND REPAIRS

Contact your local authorized service agent for service or required maintenance.

Please record the model number, serial number, voltage and purchase date in the area below and have it ready when you call to ensure a faster service.

Model No. _____
Serial No. _____
Voltage _____
Purchase Date _____

Authorized Service Agent Listing

Reference the listing provided with the unit

or

for an updated listing go to:

Website: www.star-mfg.com
E-mail Service@star-mfg.com
Telephone: (800) 807-9054 Local (314) 781-2777

Service Help Desk

Business Hours: 8:00 am to 4:30 p.m. Central Standard Time

Telephone: (800) 264-7827 Local (314) 781-2777

Fax: (800) 396-2677 Local (314) 781-2714

E-mail Parts@star-mfg.com
Service@star-mfg.com
Warranty@star-mfg.com

Website: www.star-mfg.com

Mailing Address: Star International Holdings Inc., Company
10 Sunnen Drive
St. Louis, MO 63143
U.S.A

SPECIFICATIONS:

QCSe2-300H

Type: Conveyor Toaster w/ Electronic Controls

120V, 1,700 watts, 14.1 amp, 60 hz, NEMA 5-15P Product Opening: 3" inches

Approximate shipping weight - 64 lbs (140.8 kg)

Dimensions: 14 5/8" - Width, 22 3/8" - Depth, 15 5/8" - Height / (37.1 cm - Width, 56.8 cm - Depth, 39.7 cm - Height)

QCSe2-500

Type: Conveyor Toaster w/ Electronic Controls

120V, 1,700 watts, 14.1 amp, 60 hz, NEMA 5-15P Product Opening: 1 1/2" inches

Approximate shipping weight - 64 lbs (140.8 kg)

Dimensions: 14 5/8" - Width, 22 3/8" - Depth, 15 5/8" - Height / (37.1 cm - Width, 56.8 cm - Depth, 39.7 cm - Height)

QCSe2-600H

Type: Conveyor Toaster w/ Electronic Controls

208V, 2,800 watts, 13.4 amp, 60 hz, NEMA 6-20P Product Opening: 3" inches

240V, 2,800 watts, 11.6 amp, 60 hz, NEMA 6-20P

Approximate shipping weight - 64 lbs (140.8 kg)

Dimensions: 14 5/8" - Width, 22 3/8" - Depth, 15 5/8" - Height / (37.1 cm - Width, 56.8 cm - Depth, 39.7 cm - Height)

QCSe2-800

Type: Conveyor Toaster w/ Electronic Controls

208V, 2,800 watts, 13.4 amp, 60 hz, NEMA 6-20P Product Opening: 1 1/2" inches

240V, 2,800 watts, 11.6 amp, 60 hz, NEMA 6-20P

Approximate shipping weight - 64 lbs (140.8 kg)

Dimensions: 14 5/8" - Width, 22 3/8" - Depth, 15 5/8" - Height / (37.1 cm - Width, 56.8 cm - Depth, 39.7 cm - Height)

QCSe3-950H

Type: Conveyor Toaster w/ Electronic Controls

208V, 3,200 watts, 15.3 amp, 60 hz, NEMA 6-20P Product Opening: 3" inches

240V, 3,200 watts, 13.3 amp, 60 hz, NEMA 6-20P

Approximate shipping weight - 68 lbs (149.6 kg)

Dimensions: 18 5/8" - Width, 22 3/8" - Depth, 15 5/8" - Height / (47.3 cm - Width, 56.8 cm - Depth, 39.7 cm - Height)

QCSe3-1000

Type: Conveyor Toaster w/ Electronic Controls

208V, 3,200 watts, 15.3 amp, 60 hz, NEMA 6-20P Product Opening: 1 1/2" inches

240V, 3,200 watts, 13.3 amp, 60 hz, NEMA 6-20P

Approximate shipping weight - 68 lbs (149.6 kg)

Dimensions: 18 5/8" - Width, 22 3/8" - Depth, 15 5/8" - Height / (47.3 cm - Width, 56.8 cm - Depth, 39.7 cm - Height)

QCSe3-1300

Type: Conveyor Toaster w/ Electronic Controls

208V, 3,600 watts, 17.3 amp, 60 hz, NEMA 6-30P Product Opening: 1 1/2" inches

240V, 3,600 watts, 15.0 amp, 60 hz, NEMA 6-30P

Approximate shipping weight - 68 lbs (149.6 kg)

Dimensions: 18 5/8" - Width, 22 3/8" - Depth, 15 5/8" - Height / (47.3 cm - Width, 56.8 cm - Depth, 39.7 cm - Height)

GENERAL INSTALLATION DATA



CAUTION

This equipment is designed and sold for commercial use only by personnel trained and experienced in its operation and is not sold for consumer use in and around the home nor for use directly by the general public in food service locations.

Before using your new equipment, read and understand all the instructions & labels associated with the unit prior to putting it into operation. Make sure all people associated with its use understand the units operation & safety before they use the unit.

All shipping containers should be checked for freight damage both visible and concealed. This unit has been tested and carefully packaged to insure delivery of your unit in perfect condition. If equipment is received in damaged condition, either apparent or concealed, a claim must be made with the delivering carrier.

Concealed damage or loss - if damage or loss is not apparent until after equipment is unpacked, a request for inspection of concealed damage must be made with carrier within 15 days. Be certain to retain all contents plus external and internal packaging materials for inspection. The carrier will make an inspection and will supply necessary claim forms.

INSPECTION & ASSEMBLY

UNCRATING AND INSPECTING

Unpack the unit and components from the shipping container. Remove all visible packing material and those from inside the cooking chamber. If damage is discovered, file a claim immediately with the carrier that handled the shipment. Do not operate the unit if it was damaged during shipping.

ASSEMBLY AND INSTALLATION

The unit was shipped fully assembled and ready to plug into a standard outlet specified for its voltage and amp draw. If improper electrical supply is determined, contact a qualified electrician prior to using the unit. Removal and replacement of the power cord and plug will void the warranty. For assistance, contact your local authorized service agent for service or required maintenance.

Level unit using the adjustable feet under the unit (approximately 1/2" adjustment).

Before using the unit for the first time, wipe down the exterior with a damp cloth.



CAUTION

Allow enough space around the toaster for adequate ventilation. Do not operate the unit without the crumb tray properly positioned. Overheating and poor toasting may occur. Read all labels on the unit and follow their instructions.

ELECTRICAL CONNECTION



WARNING

Before making any electrical connection to this unit, check that the power supply is adequate for the voltage, amperage and requirements stated on the rating plate.

A wiring diagram is included herewith.

Never plug a 208V unit into 240V or 240V unit into a 208V.

Disconnect the unit from the power source before installing or removing any parts.

Be absolutely sure that the ground connection for the receptacle is properly wired. Do not connect equipment to power without proper ground connections. Improper grounding may result in personal injury or fatality.



WARNING

DO NOT CUT OR REMOVE THIS PLUG OR GROUNDING PRONG FROM THE PLUG.



WARNING

CONNECT/PLUG UNIT INTO DEDICATED A.C. LINE ONLY SPECIFIED ON THE DATA PLATE OF THE UNIT.



DAILY OPERATION

The Holman QCSe conveyor toaster comes with pre-programmed factory default settings for TOAST, MUFFINS, and BAGELS. The operator may change these setting at any time. A button labeled OTHER is provided to allow the operator to program settings for additional product(s).

Press TOAST and TST will appear in the display.

Press MUFFIN and MUF will appear in the display.

Press BAGEL and BGL will appear in the display.

Press OTHER and OTH will appear in the display.

LIGHT and **DARK** buttons are used to change the conveyor speeds when in toast, muffin, or bagel modes.

Pressing the (**LIGHT**) button once will increase the conveyor speed by 15%. Pressing twice (**XLIGHT**) will increase the conveyor speed by 30%.

Pressing the (**DARK**) button once will decrease the conveyor speed by 10%. Pressing twice (**XDARK**) will decrease the conveyor speed by 20%.

Note: After 60 seconds the conveyor speed will return to the pre-programmed setting.

The factory default settings are as follow:

TOAST AND OTHER

TOP HEAT	9
BOTTOM HEAT	9
CONVEYOR	59

BAGEL:

TOP HEAT	9
BOTTOM HEAT	9
CONVEYOR	24

OTHER:

TOP HEAT	9
BOTTOM HEAT	9
CONVEYOR	59

POWER SAVER:

TIME (minutes)	60
HEAT	5

The QCSe toaster is equipped with a Power Saver Switch (SAVER) that reduces the power used by the toaster after a pre-programmed period of time. This Power Saver Switch has three modes:

ON: Unit is in pre-programmed power saving setting.

OFF: Power Saver mode is turned off.

AUTO ON: Power Saver turns on when there has been no activity for a programmed length of time.

The operator may adjust the level of power reduction for the saver mode. (Note: conveyor may move slowly when in saver mode.)

Two buttons (+) and (-) are used when increasing or decreasing the value of each programmable setting.

A red LED light located at the lower portion of the control panel label will indicate if the value for top heat, bottom heat or conveyor speed is being adjusted.



CAUTION

CERTAIN SURFACES ARE EXTREMELY HOT DURING OPERATION AND CARE SHOULD BE TAKEN WHILE USING THIS UNIT.

START UP

When the toaster has been plugged into a suitable outlet and power supply, the word **OFF** will be displayed on the L.E.D. read out.

- A.** Press the *ON/OFF* button once to turn on the toaster. The toaster will now enter into pre-heat and **PREHT** will be displayed (the elements will begin to glow but the conveyor and fan motor will not turn on).
- B.** **After one minute**, the fan motor will turn on and the conveyor will begin turning at the previously saved setting (for initial start up, the drive motor will operate at the factory default setting).
- C.** **After four minutes**, the display will show the last used program selection i.e. **TOAST, BAGEL, MUFFIN** or **OTHER** (for initial startup, **TOAST** will be the last program selected).

DAILY OPERATION

Check the power cord to insure that it is plugged into a proper outlet.

Press the *ON/OFF* button once to turn the toaster on.

Press the button a second time to turn the toaster off.

NOTE: When the toaster is turned off, the fan and conveyor motors will continue to run for five minutes. The words **COOL** and **DOWN** will be alternately displayed during that time. After five minutes, the word **OFF** will be displayed until the *ON/OFF* button is pressed again.

For units equipped with a **POWER SAVER** feature, the three operating modes are:

ON Unit has entered the pre-programmed level of power savings.

OFF Power Saver feature is turned off.

AUTO If the toaster has been idle for a pre-set period of time, the unit enters Power Saver mode until one of the menu buttons has been pressed.

Once the toaster has been pre-heated, the menu buttons can be pressed to change to **TOAST, BAGEL, MUFFIN, or OTHER.**



OPERATING HINTS AND SAFETY

Disconnect power to the unit with the **ON/OFF** button at the end of each day of operation.

Do not leave the unit in operation without an attendant.

Turn the **POWER SAVER** Switch to Standby during idle periods. It will take only a few minutes to regain operating temperature.

Do not leave the unit at high temperature when not in use or during idle periods. This will cause food particles and grease film to carbonize.

TOASTER COMPONENTS

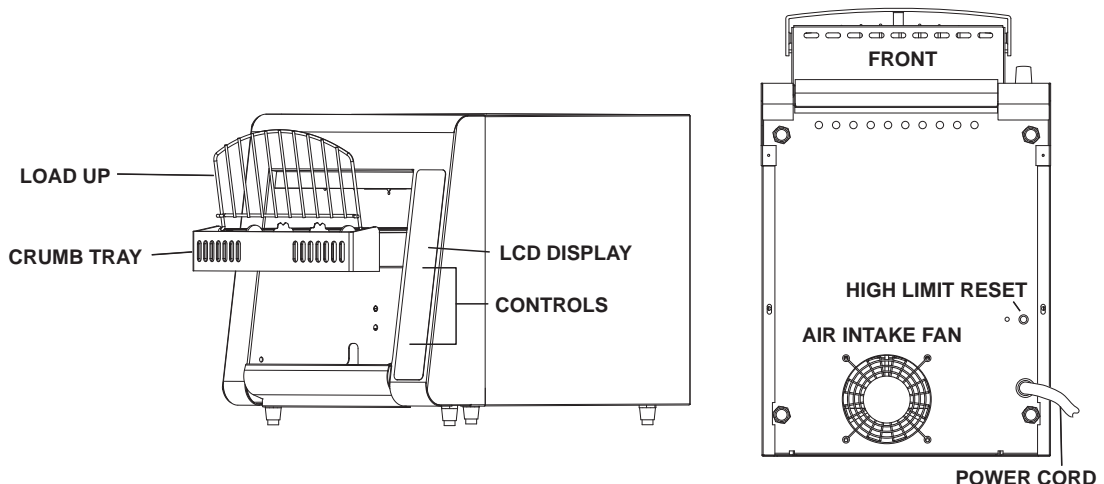

PROGRAMING

A. CONVEYOR SPEED (temporary setting)

The conveyor speed is programmable with a range from 0 to 99 with 0 being the slowest and 99 being the fastest. Each menu item can have independent conveyor speed settings.

The *LIGHT* and *DARK* buttons can be used to temporarily change the conveyor speed. Pressing the *LIGHT* button once will increase the conveyor speed by 15%. The word **LIGHT** will be displayed. Pressing twice will increase the conveyor speed by 30% and **XLIGHT** will now be displayed.

Pressing the *DARK* button once will decrease the conveyor speed by 15%. The word **DARK** will be displayed. Pressing twice will decrease the conveyor speed by 30% and **XDARK** will now be displayed.

NOTE: After 60 seconds, the conveyor speed will return to the pre-programmed setting.

WHEN USING THE LIGHT AND DARK BUTTONS TO ADJUST THE CONVEYOR SPEED FOR A SINGLE ORDER OF PRODUCT, IT IS IMPORTANT TO REMEMBER TO ALLOW THE PRODUCT ALREADY IN THE TOASTER TO EXIT BEFORE CHANGING THE SPEED SETTING.

B. PROGRAMING VALUES FOR MENU ITEMS

To make a program change to the top heat, bottom heat, or conveyor speed, you must first be in the menu item you want changed. Example: to change the programmed conveyor speed for bagels, the display must read **BAGEL**. To change the programmed conveyor speed for TOAST, the display must read **TOAST** and so on for each menu item.

- 1) Select the menu item you want to change i.e. **TOAST, MUFFIN, BAGEL** or **OTHER**.
- 2) Press and hold both (+) AND (-) buttons for 3 seconds until the display goes blank, release the buttons and the display will show three characters for the menu item elected and the last two characters for the current value setting, i.e. **TST, MUF, BGL** and **OTH**. The red L.E.D. light for top heat at the bottom of the label will flash.
- 3) Press the (+) or (-) buttons to increase or decrease the setting for the top heat.
- 4) Press the button for the menu button again and the red L.E.D. for the bottom heat will flash.
- 5) Press the (+) or (-) buttons to increase or decrease the setting for the bottom heat.
- 6) Press the button for the menu button again and the red L.E.D. for the conveyor speed will flash.
- 7) Press the (+) or (-) buttons to increase or decrease the setting for the conveyor speed.
- 8) To skip one feature setting with out making any changes, press the menu item button one time and the red L.E.D. light for the next item will now flash.
- 9) To change the POWER SAVER values press the SAVER button or to save your new setting(s), and exit the program mode press the menu button.
- 10) The last two characters in the display will show **MN** for minutes.
- 11) The first three characters will be numerical to represent the time setting.
- 12) Press the (+) or (-) buttons to increase or decrease the setting for the savor mode time. The minimum value is **15** minutes to maximum value of **480** minutes.
- 13) Press the SAVER button to change the power reduction using the (+) or (-) buttons to increase or decrease the setting.
- 14) Press the POWER SAVER button to save changes and to exit.

CLEANING

Preventive maintenance for your Holman toaster consists of the following recommended cleaning procedures. To keep your toaster in its top operating condition, these steps should be performed on a daily or weekly as indicated.

- A. Clean air intake on bottom of unit, and making sure it is free from any obstruction.
- B. For lightly soiled conveyor belts, turn conveyor speed control to fastest setting (100) and wipe with a damp cloth (daily) For heavily soiled conveyors, turn conveyor speed control to fastest setting and wipe with a light abrasive pad (as needed). Wipe conveyor with damp cloth.
- C. Turn main power saver switch to the OFF position. Disconnect unit from power source.
- D. After the unit cools, remove interior crumb tray (as shown below) and clean. Slide crumb tray back into position.
- E. Wipe exterior surface of unit.

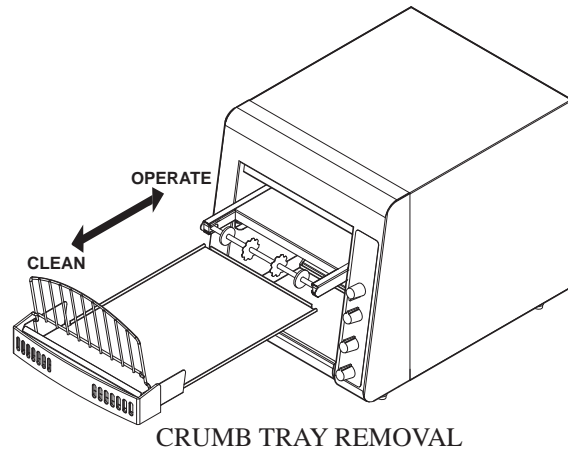

WARNING

DO NOT IMMERSE OR LET THE UNIT STAND IN WATER.

DO NOT HOSE DOWN THE UNIT OR THE TABLE/COUNTER IF THE UNIT IS ON THE TABLE/COUNTER.

KEEP AWAY FROM RUNNING WATER.

MAINTENANCE PROCEDURES

A. REPLACING HEATER TUBES

- 1) **DISCONNECT UNIT FROM POWER SOURCE.**
- 2) Remove the enclosure.
- 3) Remove heater tube wire from terminal block connection, keeping top and bottom wires separate.
- 4) Lift heater tube retainers by loosening retaining screws and sliding the retainer plate up. Hand tighten the plate to hold it up so the heater tubes will slide out freely.
- 5) Gently, pull defective heater tube out of unit.
- 6) Gently, put new heater tube into unit.
- 7) Loosen retainer screws and slide the retainer back into place. Tighten the screw to secure the retainer in place over the ends of the heater tubes.

B. REPLACING FAN MOTOR

- 1) **DISCONNECT UNIT FROM POWER SOURCE.**
- 2) Remove screws from the enclosure and the back panel at rear of unit.
- 3) Remove the enclosure and the back panel.
- 4) Unplug power supply cord from fan motor.
- 5) Remove (4) screws, which hold fan motor and grill to bottom of unit and remove fan.
- 6) Put replacement motor and grill in place and secure to the bottom of unit with screws.
- 7) Reconnect power supply cord to fan motor.
- 8) Replace back panel and enclosure. Fasten with screws removed in step 2.

C. REPLACING BELT DRIVE MOTOR

- 1) **DISCONNECT UNIT FROM POWER SOURCE.**
- 2) Remove enclosure and back panel.
- 3) Remove sprocket from motor shaft, using an Allen wrench and loosening the set-screw.
- 4) Remove the wire from terminal block connecting the drive motor to internal wiring.
On units rated 208 or 240 volts, note which color leads are being used for these connections and which lead is capped with white tape. The new motor should use the same arrangement.
- 5) Remove screws holding motor in place and remove motor from unit.
- 6) Put new motor in place and attach loosely with mounting screws.
- 7) Replace sprocket on motor shaft & ensure it is flush with the driven sprocket.

NOTE: The two sprockets should line up parallel with each other, so the chain does not twist any during operation. Also the hub gets installed closets to the motor.

- 8) Slide motor until the drive chain has about 1/4" slack when lightly pushed at the center of its top open run. *See chain tensioning illustration.*
- 9) Tighten screws to secure motor.
- 10) Rewire leads same as removed in step 4.
- 11) Replace side panel and control box cover.

D. CLEANING AIR INTAKE ONCE A WEEK

- 1) **DISCONNECT UNIT FROM POWER SOURCE.**
- 2) Place unit on its backside.
- 3) Use a vacuum cleaner and or a damp cloth to clean the air intake. This procedure should be done at least

E. LUBRICATE THE CHAIN & SPROCKETS EVERY 6 MONTHS

- 1) **DISCONNECT UNIT FROM POWER SOURCE.**
- 2) Remove enclosure exposing chain drive.
- 3) Using an extreme pressure, synthetic chain lubricant with a temperature range up to 400°F. Apply liberally onto chain and sprockets. This grease is available as part no. 1P-Z8914.
- 4) Replace enclosure, Reconnect power source and test unit.

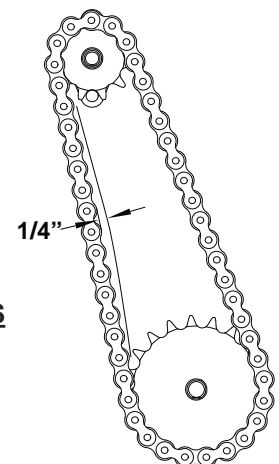

QCS/RCS Chain Tension

TROUBLESHOOTING GUIDE

A. UNIT WILL NOT HEAT, CONVEYOR BELT WILL NOT MOVE.

- 1) Be sure the main circuit breaker is switched to the ON position.
- 2) Check to see if the toaster is plugged in and all controls are turned to the ON position.

B. UNIT HAS HEAT ONLY ON ONE SIDE, CONVEYOR BELT TURNS FREELY.

- 1) Call the Star Service Help Desk at 1-800-807-9054, as heating element may need replacing.

C. CONVEYOR WILL NOT TURN, UNIT HEATS PROPERLY.

To check for mechanical binding:

- 1) **DISCONNECT UNIT FROM POWER SOURCE.**
- 2) Remove 2 screws holding enclosure to the bottom of the unit.
- 3) Set unit on the legs and remove 4 screws on the back of the toaster.
- 4) Slide the enclosure off the unit and remove the back panel.
- 5) Loosen the four screws that hold the drive motor in place.
- 6) Slide the motor up allowing the drive chain to be removed from the sprockets.
- 7) Move the conveyor belt by hand to check for mechanical binding. If conveyor moves freely, call the Star Service Help Desk at 1-800-807-9054, as the drive motor and/or speed control may need replacing.
- 8) Replace the enclosure by sliding it forward towards the front of the unit.

The front edge of the enclosure will slide beneath the toaster front.

D. HEAT LIMIT SWITCH (RESET)

Your Holman conveyor toaster is equipped with an automatically activated heat limit switch that interrupts the heater tube connections if the ambient temperature in the control box exceeds 190°F (88C). This switch can be reset manually by pushing the red button under the toaster as shown in the Toaster Components Illustration on Page 5.

- 1) **DISCONNECT UNIT FROM POWER SOURCE.**
- 2) Check to see if air intake area in the bottom center of the control box cover is free of dust, grease or other obstructions.
- 3) Check if crumb tray is in place. **NEVER OPERATE UNIT WITHOUT CRUMB TRAY IN PLACE AS THIS CAUSES OVERHEATING IN THE CONTROL BOX.**
- 4) If no obstructions to the airflow can be found and if the crumb tray is in place, call the Star Service Help Desk at 1-800-807-9054 for assistance.

E. CONVEYOR TURNS AT ONE SPEED REGARDLESS OF SPEED CONTROL SETTING.

- 1) Call the Star Service Help Desk at 1-800-807-9054, as the control board may need to be replaced.

Visit our Website at: www.star-mfg.com

Email: service@star-mfg.com

THOROUGHLY INSPECT YOUR UNIT ON ARRIVAL

This unit has been tested for proper operation before leaving our plant to insure delivery of your unit in perfect condition. However, there are instances in which the unit may be damaged in transit. In the event you discover any type of damage to your product upon receipt, you must immediately contact the transportation company who delivered the item to you and initiate your claim with same. If this procedure is not followed, it may affect the warranty status of the unit.

LIMITED EQUIPMENT WARRANTY

All workmanship and material in Star products have a one (1) year limited warranty on parts & labor in the United States and Canada. Such warranty is limited to the original purchaser only and shall be effective from the date the equipment is placed in service. Star's obligation under this warranty is limited to the repair of defects without charge, by the factory authorized service agency or one of its sub-agencies. Models that are considered portable (*see below*) should be taken to the closest Star service agency, transportation prepaid.

- > Star will not assume any responsibility for loss of revenue.
- > On all shipments outside the United States and Canada, see International Warranty.
- * The warranty period for the JetStar six (6) ounce & Super JetStar eight (8) ounce series popcorn machines is two (2) years.
- * The warranty period for the Chrome-Max Griddles is five (5) years on the griddle surface. See detailed warranty provided with unit.
- * The warranty period for Teflon/Dura-Tec coatings is one year under normal use and reasonable care. This warranty does not apply if damage occurs to Teflon/Dura-Tec coatings from improper cleaning, maintenance, use of metallic utensils, or abrasive cleaners, abrasive pads, product identifiers and point-of-sale attachments, or any other non-food object that comes in continuous contact with the roller coating. This warranty does not apply to the "non-stick" properties of such materials.
- > This warranty does not apply to "Special Products" but to regular catalog items only. Star's warranty on "Special Products" is six (6) months on parts and ninety (90) days on labor.
- > This warranty does not apply to any item that is disassembled or tampered with for any purpose other than repair by a Star Authorized Service Center or the Service Center's sub-agency.
- > This warranty does not apply if damage occurs from improper installation, misuse, wrong voltage, wrong gas or operated contrary to the Installation and Operating instructions.
- > This warranty is not valid on Conveyor Ovens *unless* a "start-up/check-out" has been performed by a Factory Authorized Technician.

PARTS WARRANTY

Parts that are sold to repair out of warranty equipment are warranted for ninety (90) days. The part only is warranted. Labor to replace the part is chargeable to the customer.

SERVICES NOT COVERED BY WARRANTY

1. Travel time and mileage rendered beyond the 50 mile radius limit
2. Mileage and travel time on portable equipment (*see below*)
3. Labor to replace such items that can be replaced easily during a daily cleaning routine, ie; removable kettles on fryers, knobs, grease drawers on griddles, etc.
4. Installation of equipment
5. Damages due to improper installation
6. Damages from abuse or misuse
7. Operated contrary to the Operating and Installation Instructions
8. Cleaning of equipment
9. Seasoning of griddle plates
10. Voltage conversions
11. Gas conversions
12. Pilot light adjustment
13. Miscellaneous adjustments
14. Thermostat calibration and by-pass adjustment
15. Resetting of circuit breakers or safety controls or reset buttons
16. Replacement of bulbs
17. Replacement of fuses
18. Repair of damage created during transit, delivery, & installation OR created by acts of God

PORTABLE EQUIPMENT

Star will not honor service bills that include travel time and mileage charges for servicing any products considered "Portable" including items listed below. These products should be taken to the Service Agency for repair:

- * The Model 510FD Fryer.
- * The Model 526TOA Toaster Oven.
- * The Model J4R, 4 oz. Popcorn Machine.
- * The Model 518CMA & 526CMA Cheese Melter.
- * The Model 12MC & 15MC & 18MCP Hot Food Merchandisers.
- * The Model 12NCPW & 15NCPW Nacho Chip/Popcorn Warmer.
- * All Hot Dog Equipment **except Roller Grills & Drawer Bun Warmers.**
- * All Nacho Cheese Warmers **except Model 11WLA Series Nacho Cheese Warmer.**
- * All Condiment Dispensers **except the Model HPD & SPD Series Dispenser.**
- * All Specialty Food Warmers **except Model 130R, 11RW Series, and 11WSA Series.**
- * All QCS/RCS Series Toasters **except Model QCS3 & RCS3 Series.**
- * All Fast Steamer Models **except Direct Connect Series.**

ALL:

- * Pop-Up Toasters
- * Butter Dispensers
- * Pretzel Merchandisers
(Model 16PD-A Only)
- * Pastry Display Cabinets
- * Nacho Chip Merchandisers
- * Accessories of any kind
- * Sneeze Guards
- * Pizza Ovens
(Model PO12 Only)
- * Heat Lamps
- * Pumps-Manual

The foregoing warranty is in lieu of any and all other warranties expressed or implied and constitutes the entire warranty.

FOR ASSISTANCE

Should you need any assistance regarding the Operation or Maintenance of any Star equipment; write, phone, fax or email our Service Department. In all correspondence mention the Model number and the Serial number of your unit, and the voltage or type of gas you are using.

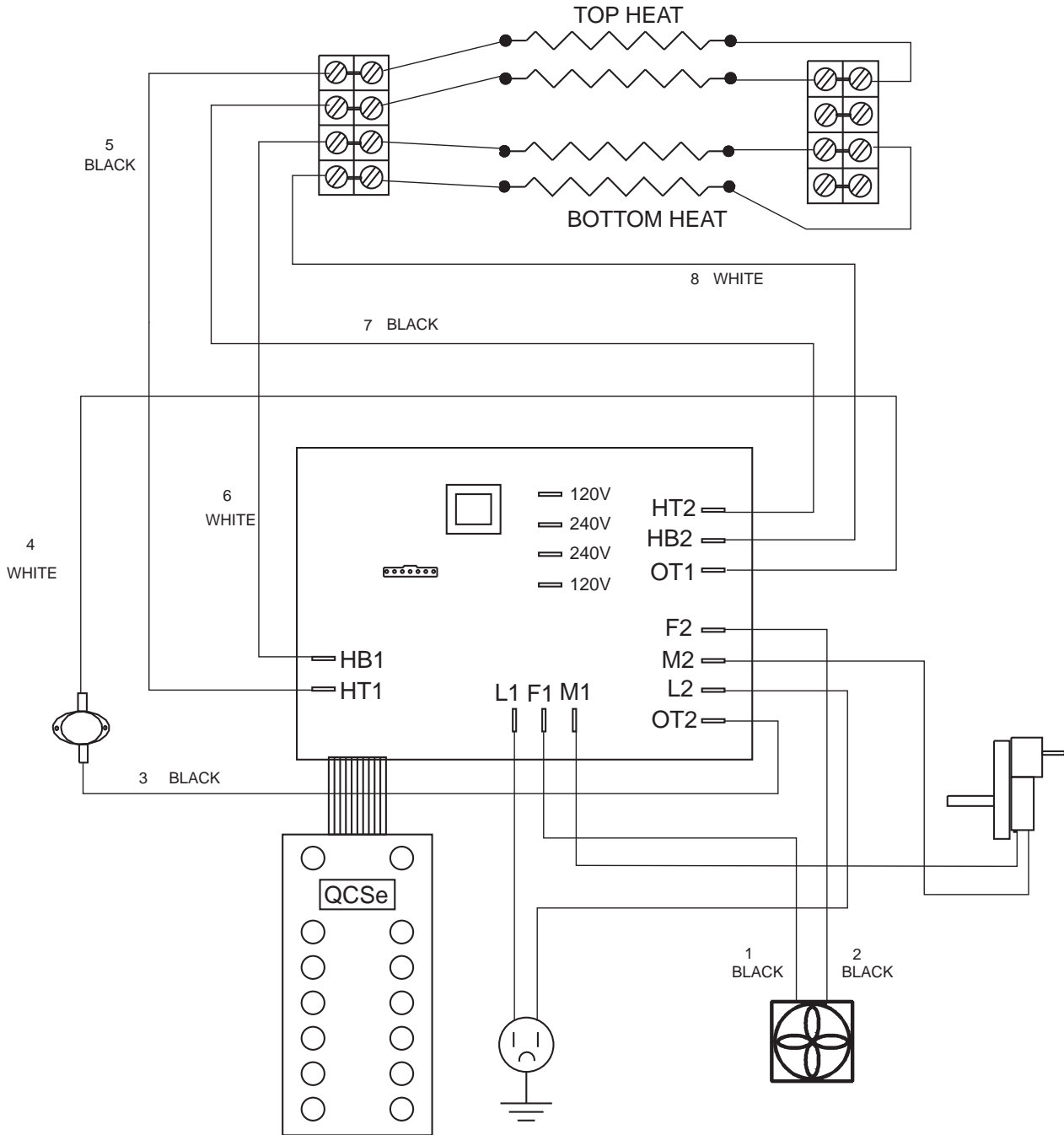

WD# 2M-Z10874
 DATE CODE - 0708 REV-0

HOLMAN
WIRING DIAGRAM - QCSe - 4 Tube Series

THIS DRAWING CONTAINS INFORMATION CONFIDENTIAL TO STAR MFG. INT'L. INC.
 NO REPRODUCTION OR DISCLOSURE OF ITS CONTENTS IS PERMITTED.



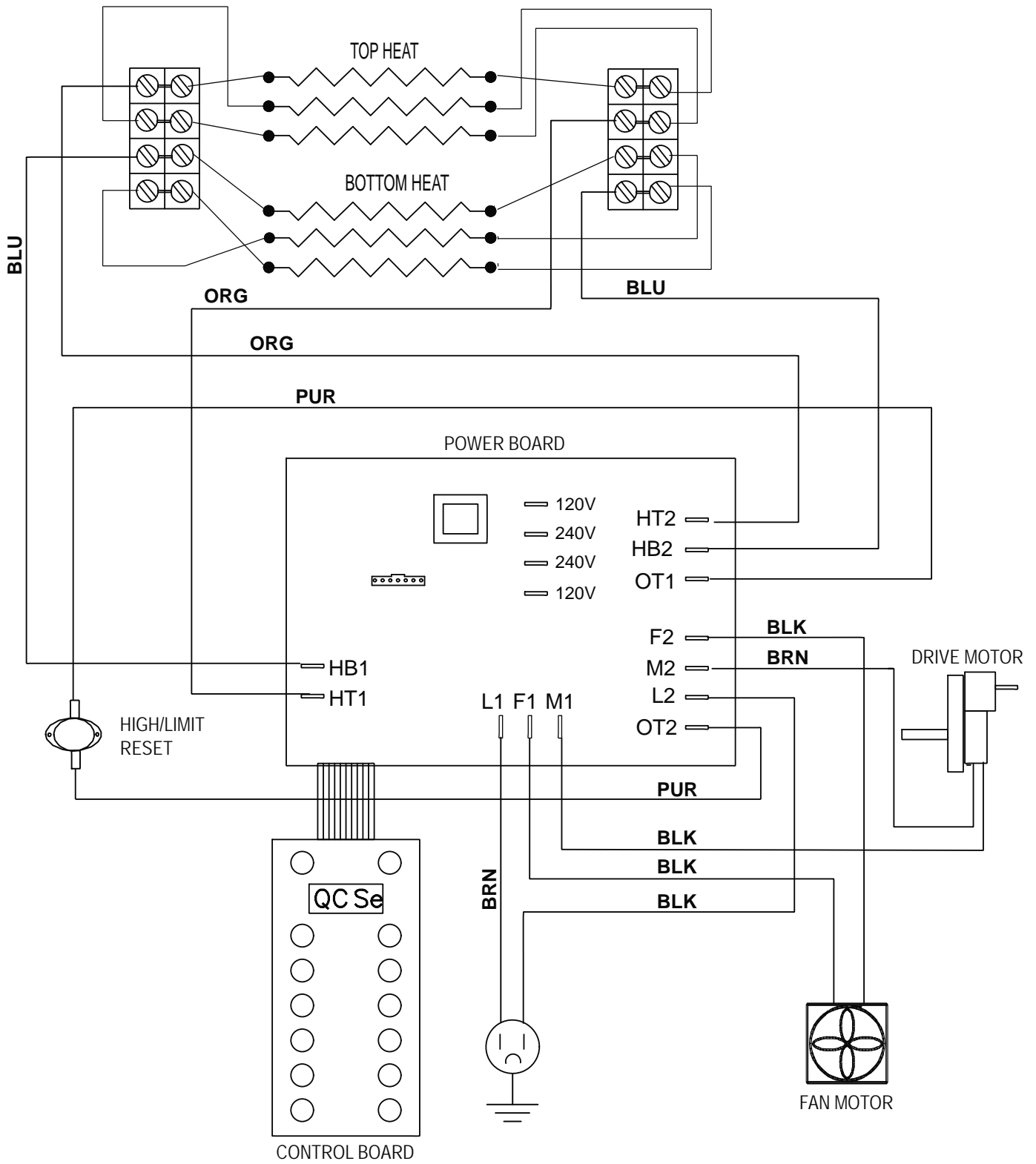

**HOLMAN
WIRING DIAGRAM - QCSe - 6 Tube Series**

THIS DRAWING CONTAINS INFORMATION CONFIDENTIAL TO STAR MFG. INT'L. INC.
NO REPRODUCTION OR DISCLOSURE OF ITS CONTENTS IS PERMITTED.



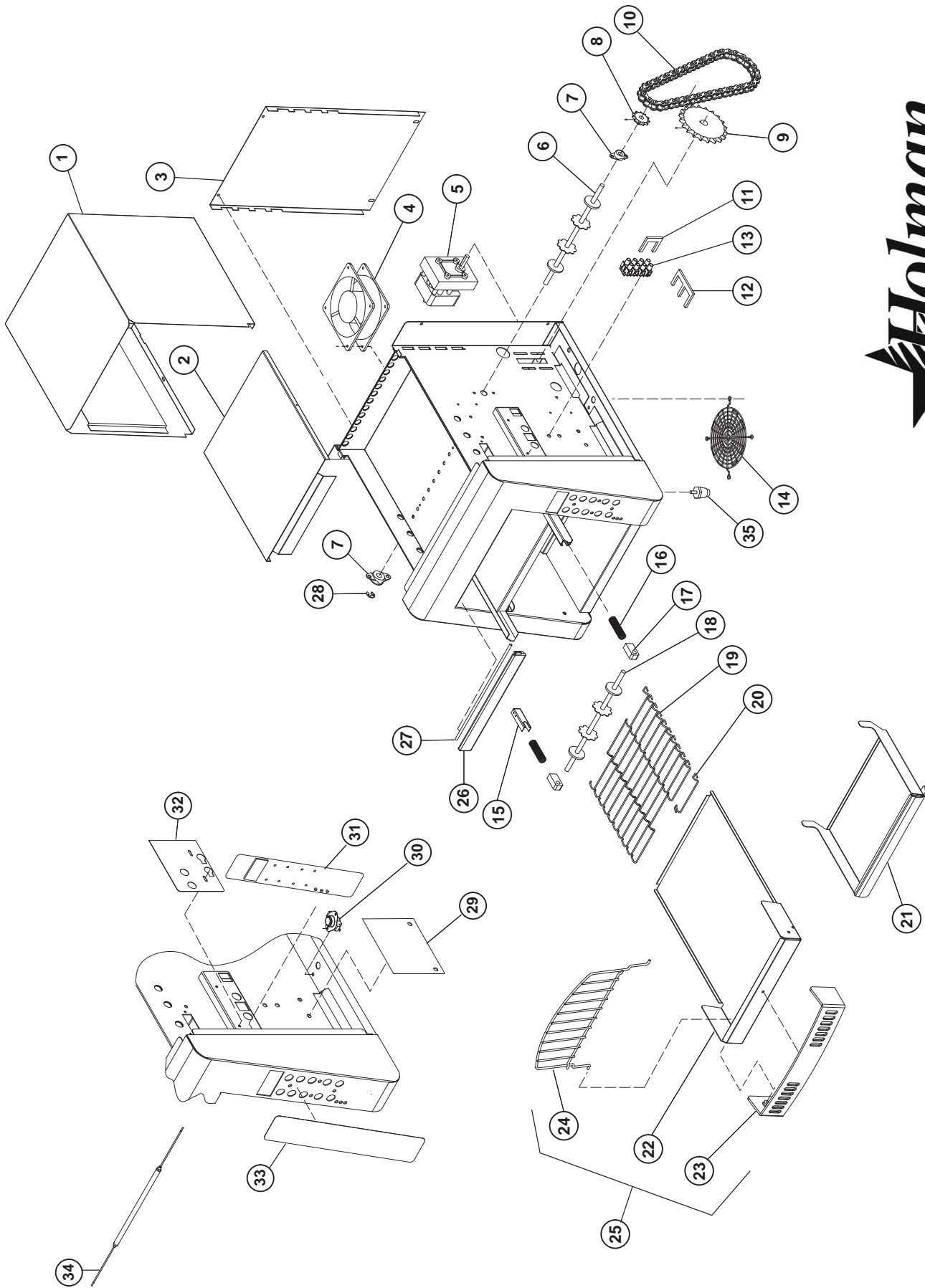

SK2134 Rev A 1/26/2006

MODEL: QCSe CONVEYOR TOASTER

THIS DRAWING CONTAINS INFORMATION CONFIDENTIAL TO STAR MFG. INT'L. INC.
NO REPRODUCTION OR DISCLOSURE OF ITS CONTENTS IS PERMITTED.

**QCSe-2-300H, QCSe-2-500
Conveyor Toasters**

Key Number	Part Number	Number Per Unit	Description & Model
1	HC-101370	1	ENCLOSURE, QCS2
2	HC-100570	1	BAFFLE, AIR FLOW HIGH QCSe-300
2	HD-100571	1	BAFFLE, AIR FLOW LOW QCSe-500
3	HF-402449	1	PANEL, BACK, QCS2
4	2U-200559	1	MOTOR, FAN
5	HD-115070	1	MOTOR, DRIVE RMS2020, FAN, W/TERMINALS
	2R-Z8879	1	FAN BLADE, DRIVE MOTOR
6	2A-202904	1	SHAFT, IDLER
7	HA-112261	2	BUSHING, REAR
8	2P-Z8779	1	SPROCKET, DRIVEN (25B11 X 5/16")
9	2P-200645	1	SPROCKET, DRIVE (25B17 X 5/16")
10	2P-150013	1	CHAIN, DRIVE (19")
11	2P-115501	4	JUMPER, TWO POSITION, SMALL
12	2P-115502	1	JUMPER, THREE POSITION, SMALL
13	HC-115381	1	BLOCK, TERMINAL, SMALL, 4 POS.
14	2R-200562	1	GUARD, FAN
15	2A-9394	2	SPRING BRACKET
16	2P-200736	2	2" BEARING SPRING
17	2P-200700	2	BUSHING, FRONT
18	2A-202900	1	SHAFT, DRIVE
19	SP-160027	1	CONVEYOR BELT (10" X 35 - 1/2")
20	--	--	N/A
21	HA-100560	1	TRAY, PULL-OUT
22	HC-402457	1	TRAY, CRUMB
23	2R-200787	1	GUARD, CRUMB TRAY
24	2B-200763	1	WIRE RACK, LOAD-UP
25	HF-101115	1	TRAY, CRUMB ASSEMBLY, QCS - 2 TOASTER
28	2A-200284	1	E-CLIP
29	2U-200592	1	QCSe POWER BOARD
30	2E-200566	1	SWITCH, HIGH LIMIT RESET
31	2U-200591	1	QCSe CONTROL BOARD
32	HC-402499	1	RETAINER, ELEMENT
33	2M-201813	1	LABEL, CONTROL PANEL QCSe
34	HD-198042	6	HEATER TUBE, QUARTS 120V (49.33 Ω, 275W, 2.26A) (UNIT = 14.3 A)
35	2R-200709	4	LEG, 1" CHROME PLASTIC
	NOT ILLUSTRATED		
	2B-200601	1	LINK, CONVEYOR BELT
	2K-200463	1	BUSHING, CORD HEYCO
	2R-Z8879	1	FAN BLADE, DRIVE MOTOR
	HD-140072	1	CORD, POWER, NEMA 5-15 QCSe
	HD-140075	1	CORD & PLUG, FAN MOTOR QCSe
	HO-140078	1	CORD, POWER, (-V61) (CANADA)
	1P-Z12397	1 oz.	CHAIN LUBE 1oz. - TRIBOLUBE

**IMPORTANT: WHEN ORDERING, SPECIFY VOLTAGE OR TYPE GAS DESIRED
INCLUDE MODEL AND SERIAL NUMBER**

Some items are included for illustrative purposes only and in certain instances may not be available.



**QCSe-2-600H, QCSe-2-800
Conveyor Toasters**

Key Number	Part Number	Number Per Unit	Description
1	HC-101370	1	ENCLOSURE, QCS2
2	HC-100570	1	BAFFLE, AIR FLOW HI QCSe-2-600
2	HD-100571	1	BAFFLE, AIR FLOW LOW QCSe-2-800
3	HF-402449	1	PANEL, BACK, QCS2
4	2U-200560	1	MOTOR, FAN
5	HI-115071	1	MOTOR, DRIVE, FAN, W TERMINALS
	2R-Z8879	1	FAN BLADE, DRIVE MOTOR
6	2A-202900	1	SHAFT, DRIVE
7	HA-112261	2	BUSHING, REAR
8	2P-Z8779	1	SPROCKET, DRIVEN (25B11 X 5/16")
9	2P-200645	1	SPROCKET, DRIVE (25B17 X 5/16")
10	2P-150013	1	CHAIN, DRIVE (19")
11	2P-115501	3	JUMPER, TERMINAL BLOCK, SMALL, 2 POS.
12	2P-115502	1	JUMPER, TERMINAL BLOCK, SMALL, 3 POS.
13	HC-115381	2	BLOCK, TERMINAL, SMALL, 4 POS.
14	2R-200562	1	GUARD, FAN MOTOR
15	2A-z9394	2	SRING BRACKET
16	2P-200736	2	2" BEARING SPRING
17	2P-200700	2	BUSHING, FRONT
18	2A-202904	1	SHAFT, IDLER
19	SP-160027	1	BELT, CONVEYOR (10" X 35 - 1/2")
20	--	--	N/A
21	HA-100560	1	TRAY, PULL-OUT
22	HC-402457	1	CRUMB TRAY
23	2R-200787	1	CRUMB TRAY GUARD
24	2B-200763	1	LOAD-UP WIRE RACK Certain Models
25	HF-101115	1	CRUMB TRAY ASSEMBLY, QCS - 2 TOASTER
26	HC-402206	1	HEAT SHUTTER, SWINGING
27	HC-402134	1	ROD, SHUTTER
28	2A-200284	1	E-CLIP
29	2U-200592	1	POWER BOARD
30	2E-200566	1	SWITCH, HIGH LIMIT RESET
31	2U-200591	1	QCSe CONTROL BOARD
32	HC-402706	1	RETAINER, ELEMENT, 4 TUBE
33	2M-201813	1	LABEL, CONTROL PANEL
34	HO-197841	4	HEATER TUBE, QUARTS 208V (15.5 Ω, 703W) (UNIT = 13.52 A)
34	HO-197842	4	HEATER TUBE, QUARTS 240V (19.2 Ω, 707W) (UNIT = 11.78 A)
35	2R-200709	4	LEG, 1" CHROME PLASTIC
	NOT ILLUSTRATED		
	2B-200601	1	LINK, CONVEYOR BELT 10"
	2K-200463	1	BUSHING, CORD HEYCO
	2R-Z8879	1	FAN BLADE, DRIVE MOTOR
	HD-140075	1	CORD, FAN MOTOR
	HI-140076	1	CORD, POWER (NEMA 6-20P)
	2E-Z13364	1	CORD SET 14GA 6-20P 80" Wendy's Q2E-600HW208/240
	1P-Z12397	1 oz.	CHAIN LUBE 1oz. - TRIBOLUBE

**IMPORTANT: WHEN ORDERING, SPECIFY VOLTAGE OR TYPE GAS DESIRED
INCLUDE MODEL AND SERIAL NUMBER**

PAGE 1
OF 1

Some items are included for illustrative purposes only and in certain instances may not be available.



**QCSe-3-950H, QCSe-3-1000
Conveyor Toasters**

Key Number	Part Number	Number Per Unit	Description
1	HH-101371	1	ENCLOSURE, QCS3
2	HH-100572	1	BAFFLE, AIR FLOW, HI QCSe-3-950H
2	HI-100573	1	BAFFLE, AIR FLOW, LOW QCSe-3-1000H
3	HH-402470	1	PANEL, BACK, QCS3
4	2U-200561	1	MOTOR, FAN
5	HI-115071	1	MOTOR, DRIVE, RMS72 W/TERMINALS
	2R-Z8879	1	FAN BLADE, DRIVE MOTOR
6	2A-202902	1	SHAFT, DRIVE
7	HA-112261	2	BUSHING, REAR
8	2P-Z8779	1	SPROCKET, DRIVEN (25B11 X 5/16")
9	2P-200645	1	SPROCKET, DRIVE (25B17 X 5/16")
10	2P-150013	1	CHAIN, DRIVE (19")
11	2P-115501	3	JUMPER, TERMINAL BLOCK, SMALL, 2 POS.
12	2P-115502	1	JUMPER, TERMINAL BLOCK, SMALL, 3 POS.
13	HC-115381	2	BLOCK, TERMINAL. SMALL, 4 POS.
14	2R-200562	1	GUARD, FAN MOTOR
15	2A-Z9394	2	SPRING BRACKET
16	2P-200736	2	2" BEARING SPRING
17	2P-200700	2	BUSHING, FRONT
18	2A-202905	1	SHAFT, IDLER
19	SP-160028	1	CONVEYOR, BELT (14" X 35")
20	2B-200603	3	LINK, MASTER, CONVEYOR BELT
21	HH-100561	1	TRAY, PULL-OUT
22	HH-402465	1	TRAY, CRUMB
23	2R-200788	1	GUARD, CRUMB TRAY
24	2B-200764	1	WIRE RACK, LOAD-UP
25	HI-101116	1	TRAY, CRUMB ASSEMBLY, QCS - 3 TOASTER
26	HH-401695	1	HEAT SHUTTER, SWINGING QCSe-3-950H
27	HH-402135	1	ROD, HEAT SHUTTER QCSe-3-950H
28	2A-200284	1	E-CLIP
29	2U-200592	1	POWER BOARD
30	2E-200566	1	SWITCH, HIGH LIMIT RESET
31	2U-200591	1	QCSe CONTROL BOARD
32	HC-402706	1	RETAINER, ELEMENT, 4 TUBE
33	2M-201813	1	LABEL, CONTROL PANEL
34	GB-197847	4	HEATER TUBE QUARTS, 240V (16.85 Ω, 806W, 6.7A) (UNIT = 13.3 A)
34	HT-197845	4	HEATER TUBE QUARTS, 208V (12.64 Ω, 807W, 7.75A) (UNIT = 15.4 A)
35	2R-200709	4	LEG, 1" CHROME PLASTIC
	NOT ILLUSTRATED		
	2B-200602	1	LINK, CONVEYOR BELT
	2K-200465	1	BUSHING, CORD HEYCO
	2R-Z8879	1	FAN BLADE, DRIVE MOTOR
	HD-140075	1	QCSe MOLED FAN PLUG
	HF-140073	1	CORD POWER, NEMA 6-20P
	1P-Z12397	1 oz.	CHAIN LUBE 1oz. - TRIBOLUBE

**IMPORTANT: WHEN ORDERING, SPECIFY VOLTAGE OR TYPE GAS DESIRED
INCLUDE MODEL AND SERIAL NUMBER**

PAGE 1
OF 1

Some items are included for illustrative purposes only and in certain instances may not be available.



QCSe-3-1300 Conveyor Toasters

Key Number	Part Number	Number Per Unit	Description
1	HH-101371	1	ENCLOSURE, QCS3
2	HD-100573	1	BAFFLE, AIR FLOW, LOW
3	HH-402470	1	PANEL, BACK, QCS3
4	2U-200561	1	MOTOR, FAN
5	HI-115071	1	MOTOR, DRIVE RMS72 W/TERMINALS+E26
	2R-Z8879	1	FAN BLADE, DRIVE MOTOR
6	2A-202902	1	SHAFT, DRIVE
7	HA-112261	2	BUSHING, REAR
8	2P-Z8779	1	SPROCKET, DRIVEN (25B11 X 5/16")
9	2P-200645	1	SPROCKET, DRIVE (25B17 X 5/16")
10	2P-150013	1	CHAIN, DRIVE (19")
11	2P-115501	3	JUMPER, TERMINAL BLOCK, SMALL, 2 POS.
12	2P-115502	1	JUMPER, TERMINAL BLOCK, SMALL, 3 POS.
13	HC-115381	2	BLOCK, TERMINAL. SMALL, 4 POS.
14	2R-200562	1	GUARD, FAN MOTOR
15	2A-9394	2	SPRING BRACKET
16	2P-200736	2	2" BEARING SPRING
17	2P-200700	2	BUSHING, FRONT
18	2A-202905	1	SHAFT, IDLER
19	SP-160028	1	CONVEYOR, BELT (14" X 35")
20	2B-200603	3	LINK, MASTER, CONVEYOR BELT
21	HH-100561	1	TRAY, PULL-OUT
22	HH-402465	1	TRAY, CRUMB
23	2R-200788	1	GUARD, CRUMB TRAY
24	2B-200764	1	WIRE RACK, LOAD-UP
25	HI-101116	1	TRAY, CRUMB ASSEMBLY, QCS - 3 TOASTER
28	2A-200284	1	E-CIIP
29	2U-200592	1	POWER BOARD
30	2E-200566	1	SWITCH, HIGH LIMIT RESET
31	2U-200591	1	QCSe CONTROL BOARD
32	HC-402499	1	RETAINER, ELEMENT, 6 TUBE
33	2M-201813	1	LABEL, CONTROL PANEL
34	HJ-198054	6	HEATER TUBE QUARTS, 240V (11.24 Ω, 535W, 6.71A) (UNIT = 13.3 A)
34	HJ-198060	6	HEATER TUBE QUARTS, 208V (8.4 Ω, 540W, 7.79A) (UNIT = 15.4 A)
35	2R-200709	4	LEG, 1" CHROME PLASTIC
	NOT ILLUSTRATED		
	2B-200610	1	LINK, CONVEYOR BELT
	2K-200465	1	BUSHING, CORD HEYCO
	2R-Z8879	1	FAN BLADE, DRIVE MOTOR
	HD-140075	1	CORD, FAN MOTOR, W/E21TERMINALS
	HI-140074	1	CORD, POWER (NEMA 6-30P)
	1P-Z12397	1 oz.	CHAIN LUBE 1oz. - TRIBOLUBE

**IMPORTANT: WHEN ORDERING, SPECIFY VOLTAGE OR TYPE GAS DESIRED
INCLUDE MODEL AND SERIAL NUMBER**

PAGE 1
OF 1

Some items are included for illustrative purposes only and in certain instances may not be available.



STAR INTERNATIONAL HOLDINGS INC. COMPANY
Star - Holman - Lang - Wells - Bloomfield - Toastmaster
10 Sunnen Drive, St. Louis, MO 63143 U.S.A.
(314) 781-2777
www.star-mfg.com