

MODEL:
QT14B

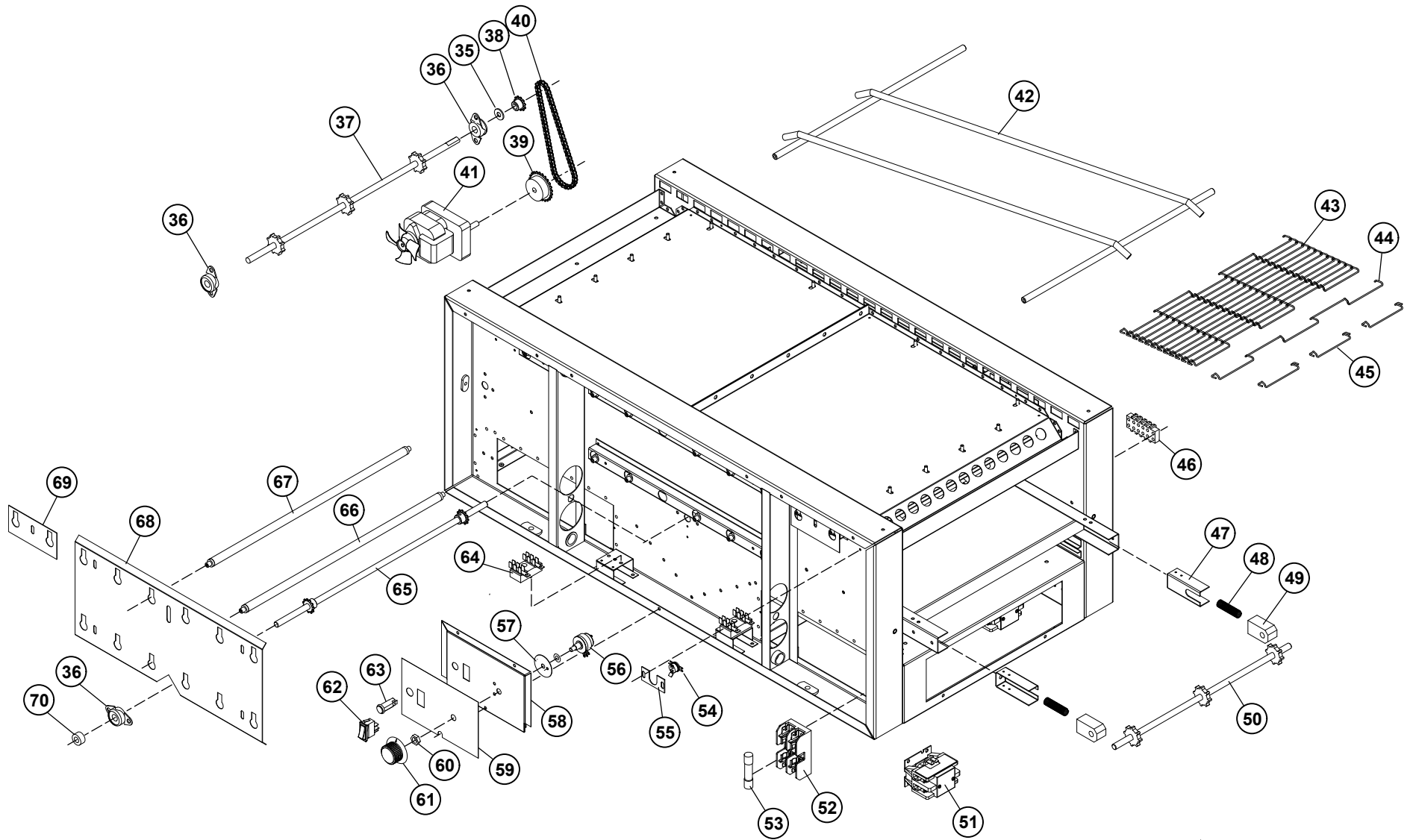

QT14B Holman Conveyor Toaster

Fig No.	Part Number	Quantity Per	Description	Fig No.	Part Number	Quantity Per	Description	
1	GE-100991	1	TOP COVER	19	GE-Z9636	1	PANEL - POWER INPUT	
2	GE-402610	1	CONVEYOR END GUARD	20	GE-402709	1	ELECTRICAL BOX (POWER INPUT)	
3	GE120303	2	CRUMB TRAY	21	2K-200464	5	BUSHING, WIRE RING 7/8"	
4	GE-Z9594	1	PANEL, CONTACTOR SIDE w/RESET	22	SP-115402	1	TERMINAL BLOCK - MAIN POWER	
5	2E-200566	1	SWITCH, OVERTEMP (RESET)	23	GE-402710	1	ELECTRICAL BOX COVER	
6	2U-200577	2	COOLING FAN - 240V HIGH OUTPUT	24	GE-101390	1	WINDOW SPACER	
7	GE-Z9598	1	PANEL - FAN OFFSET RIGHT	25	2Q-200588	1	WINDOW - NEO SARAMA	
8	2R-Z16753	1	FAN GUARD - COOLING FAN	26	GE-101028	1	PANEL - LOWER BACK	
9	2C-Z5883	8	SCREW, 10-24 X 1/2" FZA SELF DRILLING	27	GE-402689	1	PANEL - UPPER BACK	
10	GE-402654	1	CRUMB TRAY - LOWER	28	GE-402631	1	WINDOW RETAINER - OUTSIDE	
11	2M-Z9631	1	LABEL, QUIZNOS	29	GE-Z10172	1	WINDOW BLANKOFF SIDE PANEL	
12	GE-Z9596	1	PANEL - CONTROL SIDE		GE-Z9911	1	SIDE PANEL, CENTER PLAIN	
13	GE-Z9597	1	PANEL - FAN OFFSET LEFT				<i>Serial No. COQT0507B0001-20, 31-40 and above</i>	
14	2A-Z0314	4	LEG - 4"	30	GE-Z10173	1	WINDOW BLANKOFF BOX	
15	GE-Z9633	2	CONTROL BOX COVER		GE-Z9902	1	ACCESS COVER PLATE	
16	GE-Z9593	1	PANEL, MOTOR SIDE				<i>Serial No. COQT0507B0001-20, 31-40 and above</i>	
17	GE-100944	1	UNLOAD TRAY	31	2M-200816	1	BAKE AID MAGNET	
18	GE-Z9635	1	PANEL - PLAIN SIDE	32	GE-402729	1	BAKE AID BRACKET	
				71	2C-Z10075	2	SCREWM 1/4-20 X 3/8 (holds Exit Tray) use 2C-Z10076 Steel Spacer also	
				ACCESSORIES				
				33	QTEXT14	-	EXIT SHELF FOR QT14 QUIZNO'S - 14 X 28	
				34	QTEXTRY7	-	ENTRY SHELF FOR QT14 QUIZNO'S	
				NI	2E-Z9567	2	FAN CORD	
				NI	2E-200573	1	CONTRACTOR/RELAY - 3 PHASE OVENS	
				NI	2E-Z9782	2	TERMINAL BLOCK - ESE2	3 PHASE



MODEL:
QT14B



QT14B Holman Conveyor Toaster

Fig No.	Part Number	Quantity Per	Description	Fig No.	Part Number	Quantity Per	Description
35	2C-200150	1	WASHER, 3/8"	51	2E-Z8966	2	CONTACTOR/RELAY - 1 PHASE
36	GB-112262	4	BEARING ASSY. 3/8" FLANGED		PS-Z14660	1	CONTACTOR 50A 3 PHASE
37	GE-101254	1	DRIVE SHAFT ASSY (W/SPROCKETS)	52	2E-200597	1	FUSEHOLDER - 2 POSITION, TYPE G
38	2P-200652	1	SPROCKET DRIVEN -17 tooth 3/8 after COQT0307B0001	53	2E-Z8405	2	FUSE - 15A TYPE G
	2P-115362	1	SPROCKET DRIVEN -11 tooth 3/8 before COQT0301B001	54	2E-200574	1	SWITCH, FAN (COOLDOWN)
39	2P-200646	1	SPROCKET DRIVE - 20 tooth 5/16 after COQT0301B0001	55	HG-402144	1	BRACKET, FAN SWITCH
	2P-200650	1	SPROCKET DRIVE -24 tooth 5/16 before COQT0301B001	56	GE-Z9359	1	SPEED CONTROL POTENETIOMETER (500 OHM)
40	2P-150000	1	QT14 DRIVE CHAIN #25	57	2E-200180	1	INSULATION, SWITCH, POTENEIOMETER
41	PS-Z10285	1	CONVEYOR MOTOR LEFT TO RIGHT 50/60Hz	59	GE-Z9595	1	PANEL, FRONT CONTROL w/SWITCHES
	PS-Z10286	1	CONVEYOR MOTOR RIGHT TO LEFT 50/60Hz	59	2M-Z9630	1	LABEL, MAIN CONTROL
PS-Z10285 INCLUDES:			<i>s/n COQT0307B0001 or after order parts separately</i>	60		1	NUT, 3/8"-32 NEF, COMES WITH FIG. NO 52
	2U-Z9658	1	MOTOR AC 11 RPM CCW, L - R	61	2R-200761	1	KNOB, SPEED CONTROL
	2P-200652	1	SPROCKET DRIVEN -17 tooth 3/8"	62	2E-Z9592	1	SWITCH, MAIN ON/OFF
	2P-200646	1	SPROCKET DRIVE - 20 tooth 5/16"	63	2J-Z2329	1	PILOT LIGHT - RED
	2C-Z10075	1	SCREW - 1/4-20X3/8	64	2E-Z9571	2	TERMINAL BLOCK - 12 POSITION
	2A-Z10161	1	SPACER-STEEL	65	2A-101257	1	RETURN SHAFT ASSY (W/SPROCKETS)
	2M-Z10161	1	INSTRUCTIONS - QT14 DRIVE MOTOR REPLAC.	66	GE-198102	6	HEATER TUBE, 675W 208V BOTTOM, 1PH & 3PH
PS-Z10286 INCLUDES:			<i>s/n COQT0307B0001 or after order parts separately</i>		GE-198104	6	HEATER TUBE, 675W 240V BOTTOM, 1PH
	2U-Z9657	1	MOTOR AC 11 RPM CW, R - L		GE-198106	6	HEATER TUBE, 700W 220V BOTTOM, 1PH & 3PH
	2P-200652	1	SPROCKET DRIVEN -17 tooth 3/8"	67	GE-198103	10	HEATER TUBE, 375W 208V TOP, 1PH
	2P-200646	1	SPROCKET DRIVE - 20 tooth 5/16"		GE-198105	10	HEATER TUBE, 375W 240V TOP, 1PH
	2C-Z10075	1	SCREW - 1/4-20X3/8		GE-198107	10	HEATER TUBE, 375W 220V TOP, 1PH
	2A-Z10161	1	SPACER-STEEL		GE-198108	9	HEATER TUBE, 417W 380V TOP, 3PH
	2M-Z10161	1	INSTRUCTIONS - QT14 DRIVE MOTOR REPLAC.		GE-198109	9	HEATER TUBE, 417W 208V TOP, 3PH
NI	2R-200721	1	FAN BLADE - CONVEYOR MOTOR L-R		GE-198113	9	HEATER TUBE, 400W 80V 415V, TOP 3-Y PHASE
NI	2R-Z8879	1	FAN BLADE - CONVEYOR MOTOR R-L	68	GE-402359	1	HEATER TUBE RETAINER - LARGE
42	GE-100715	1	BELT SUPPORT	69	GE-402651	2	HEATER TUBE RETAINER - SMALL
43	GE-160031	1	CONVEYOR BELT W/ 3 LINKS - 82.5" LONG	70	2A-200672	3	SHAFT COLLAR - 3/8"
44	2B-200618	1	CONVEYOR BELT LINK, 14"	NI	PS-101595	1	HEATER TUBE KIT (ALL 16) 208V
45	2B-200620	3	CONVEYOR BELT SINGLE SPACE CLIP	NI	PS-101596	1	HEATER TUBE KIT (ALL 16) 240V
46	2E-Z9570	2	TERMINAL BLOCK - 4 POS.	NI	PS-Z8977	1	STACKING KIT
	2E-Z9781	2	TERMINAL BLOCK - 5 POS.	NI	2E-Z9567	2	FAN CORD
47	GE-402574	2	BEARING HOLDER	NI	2E-200573	1	CONTRACTOR/RELAY - 3 PHASE OVENS
48	2P-200766	2	SPRING, BEARING	NI	2E-Z9782	2	TERMINAL BLOCK - ESE2 3 PH
49	2P-200785	2	BEARING, SPRING LOADED	NI	1P-Z8914	1	EXTREME PRESSURE MULTIPURPOSE SYNTHETIC GREASE (80°F TO 400°F) , TUBE 8 oz.
50	GE-101255	1	IDLER SHAFT ASSY (W/SPROCKETS)				