

Holman[®] **CONVEYOR SANDWICH TOASTER**

MODEL
QT14B, QT14BR,
QT14BW, QT14BWR

Installation and Operation Instructions

2M-Z9702 Rev. I 8/19/11

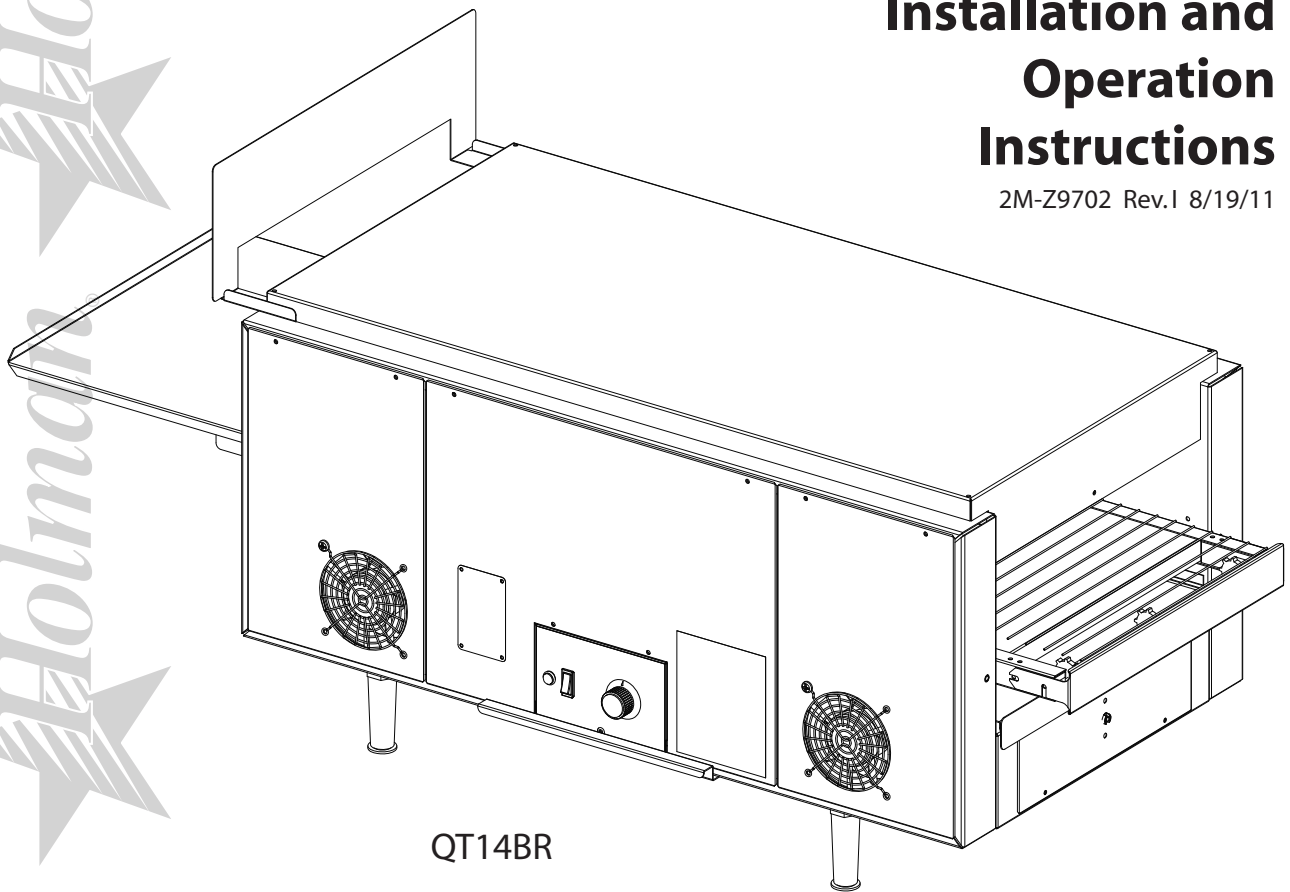

QT14BR



SAFETY SYMBOL



These symbols are intended to alert the user to the presence of important operating and maintenance instructions in the manual accompanying the appliance.

RETAIN THIS MANUAL FOR FUTURE REFERENCE NOTICE

Using any part other than genuine Star factory supplied parts relieves the manufacturer of all liability.

Star reserves the right to change specifications and product design without notice. Such revisions do not entitle the buyer to corresponding changes, improvements, additions or replacements for previously purchased equipment.

Due to periodic changes in designs, methods, procedures, policies and regulations, the specifications contained in this sheet are subject to change without notice. While Star International Holdings Inc., Company exercises good faith efforts to provide information that is accurate, we are not responsible for errors or omissions in information provided or conclusions reached as a result of using the specifications. By using the information provided, the user assumes all risks in connection with such use.

MAINTENANCE AND REPAIRS

Contact your local authorized service agent for service or required maintenance.

Please record the model number, serial number, voltage and purchase date in the area below and have it ready when you call to ensure a faster service.

Model No. _____
Serial No. _____
Voltage _____
Purchase Date _____

Authorized Service Agent Listing

Reference the listing provided with the unit

OR

for an updated listing go to:

Website: www.star-mfg.com
E-mail Service@star-mfg.com

Service Help Desk

Business Hours: 8:00 am to 4:30 p.m. Central Standard Time

Telephone: (800) 264-7827 Local (314) 684-6303

Fax: (800) 396-2677 Local (314) 781-2714

E-mail Parts@star-mfg.com
Service@star-mfg.com
Warranty@star-mfg.com

Website: www.star-mfg.com

Mailing Address: Star International Holdings Inc., Company
10 Sunnen Drive
St. Louis, MO 63143
U.S.A



TABLE OF CONTENTS

PAGE	
	Star Contact Information 2
	Specifications 3
	General Information Data 4
	Inspection & Assembly 4
	Assembly and Installation 4-5
	Electrical Connection 5
	Oven Components 5
	Stacking Ovens 6
	Daily Operation 6
	Cleaning
	Daily 7
	Weekly 8
	Monthly 9
	Maintenance and Repairs 10-11
	Troubleshooting Guide 12
	Limited Equipment Warranty 13
	Wiring Diagrams 14-16
	Exploded View Illustration & Parts List 18-21

SPECIFICATIONS

QT14B, QT14BR, QT14BW, QT14BWR

Rating/Connection: 7,800 Watts
NEMA Plug: N/A
Electrical Supply: Separate service per toaster - 37.5 Amp, 208 VAC, 1 phase, 60 Hz
Separate service per toaster - 32.5 Amp, 240 VAC, 1 phase, 60/50 Hz
Separate service per toaster - 21.7 Amp, 208 VAC, 3 phase, 60 Hz
Approximate Weight (QT14B Oven with Legs): Installed - 170 Lbs (77.1 kg)
Dimensions: Width: 55" (139.7 cm) - Oven with Trays
Depth: 24" (60.9 cm)
Height: 20" (50.8 cm) - Single Oven with Legs

QT14B, QT14BR, QT14BW, QT14BWR

Rating/Connection: 7,950 Watts
NEMA Plug: N/A 3 Phase: N/A
Electrical Supply: Separate service per toaster - 36.1 Amp, 220 VAC, 1 phase, 60 Hz
Separate service per toaster - 20.9 Amp, 220 VAC, 3 phase, 50 Hz
Separate service per toaster - 12.1 Amp, 380 VAC, 3 phase, 50 Hz
Approximate Weight (QT14B Oven with Legs): Installed - 170 Lbs (77.1 kg)
Dimensions: Width: 55" (139.7 cm) - Oven with Trays
Depth: 24" (60.9 cm)
Height: 20" (50.8 cm) - Single Oven with Legs

GENERAL INSTALLATION DATA

This equipment is designed and sold for commercial use only by personnel trained and experienced in its operation and is not sold for consumer use in and around the home nor for use directly by the general public in food service locations.



CAUTION Before using your new equipment, read and understand all the instructions & labels associated with the unit prior to putting it into operation. Make sure all people associated with its use understand the units operation & safety before they use the unit.

INSPECTION & ASSEMBLY

All shipping containers should be checked for freight damage both visible and concealed. This unit has been tested and carefully packaged to insure delivery of your unit in perfect condition. If equipment is received in damaged condition, either apparent or concealed, a claim must be made with the delivering carrier.

Concealed damage or loss - if damage or loss is not apparent until after equipment is unpacked, a request for inspection of concealed damage must be made with carrier within 15 days. Be certain to retain all contents plus external and internal packaging materials for inspection. The carrier will make an inspection and will supply necessary claim forms.

UN CRATING AND INSPECTING

Unpack the unit and components from the shipping container. Remove all visible packing material. If damage is discovered, file a claim immediately with the carrier that handled the shipment. **DO NOT** operate the unit if it was damaged during shipping.

The following should be included: Holman Conveyor Sandwich Toaster, Stainless Steel Unload Tray, (four) 4 Stainless Steel Legs, extra Motor, and Magnetic Bake Aid w/Bracket.

ASSEMBLY AND INSTALLATION

The unit was shipped with certain assembly required.



DO NOT PLACE THE UNIT ON ITS SIDE. FAILURE TO COMPLY MAY RESULT IN DAMAGE TO EQUIPMENT.

To attach the four 4 legs, with assistance place the unit on its end as shown (damage to the elements can occur when the unit is placed on its side) insert the legs by screwing them into the weld nuts located on the bottom of the unit. When completed and with help, carefully turn the unit upright.



NEVER OPERATE UNIT WITHOUT PROPER LEGS IN PLACE.

Install unit in its operating position. Level unit by adjusting the feet. Both ends must be at least 6" from any vertical combustible surface. Allow sufficient space for operating personnel.

The Unload Tray has a keyhole slot on the tray that will slide over the two screw heads on the end of the toaster as shown in the Toaster Components Illustration.

The crumb tray slides into each end of the toaster under the conveyor. The slot is formed by two pieces of metal on each side, under the toaster. They keep the interior of the machine clean and reflect heat away from the controls and back up to the sandwiches.

A layer of aluminum foil on the tray (check that it does not interfere with the conveyor) will make the tray more reflective and make cleanup easier.

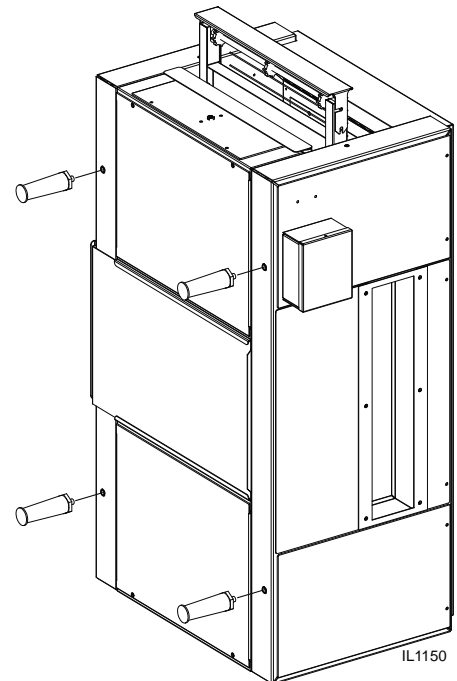

LEG INSTALLATION

ASSEMBLY AND INSTALLATION continued

ELECTRICAL CONNECTION

Have an electrician connect input power to the unit(s) in accordance with local electrical codes. A connection terminal block is located inside an electrical box on the control side of the unit. **CORD & PLUG IS NOT PROVIDED.**



VERIFY THE GROUND (EARTH) CONNECTION IS PROPERLY WIRED. NEVER CONNECT UNIT TO POWER WITHOUT PROPER GROUND CONNECTIONS. IMPROPER GROUND MAY RESULT IN SEVERE INJURY OR FATALITY.

MAKE SURE ALL INPUT POWER IS OFF BEFORE INSTALLING/REMOVING ANY PARTS.

BEFORE INSTALLING UNIT, HAVE YOUR ELECTRICIAN CHECK WITH LOCAL POWER COMPANY TO DETERMINE ACTUAL VOLTAGE AT THE STORE.

Before applying input power to the unit, check elements for breakage. **DO NOT** apply power to the unit if any elements are broken. If no broken elements are found, apply input power by switching the ON/OFF toggle to the ON position. Turn conveyor belt speed control to the maximum setting and check all elements and conveyor for proper operation.

Allow approximately 5 to 10 minutes for the twin-fan cooling system to come on. Check the air intake fan area shown below, making sure there is a sufficient flow of air into the unit. Restricting the airflow will cause the unit to run hotter than designed causing damage to the unit.

If all heater and conveyor systems are operating properly, turn the master ON/OFF switch to the OFF position and allow unit to cool. The fans will continue to circulate cool air throughout the unit until the internal temperatures have been decreased.

If a problem is discovered during start up procedures, immediately turn the Master ON/OFF switch to the OFF position and call the Star Service Help Desk at 1-800-807-9054.

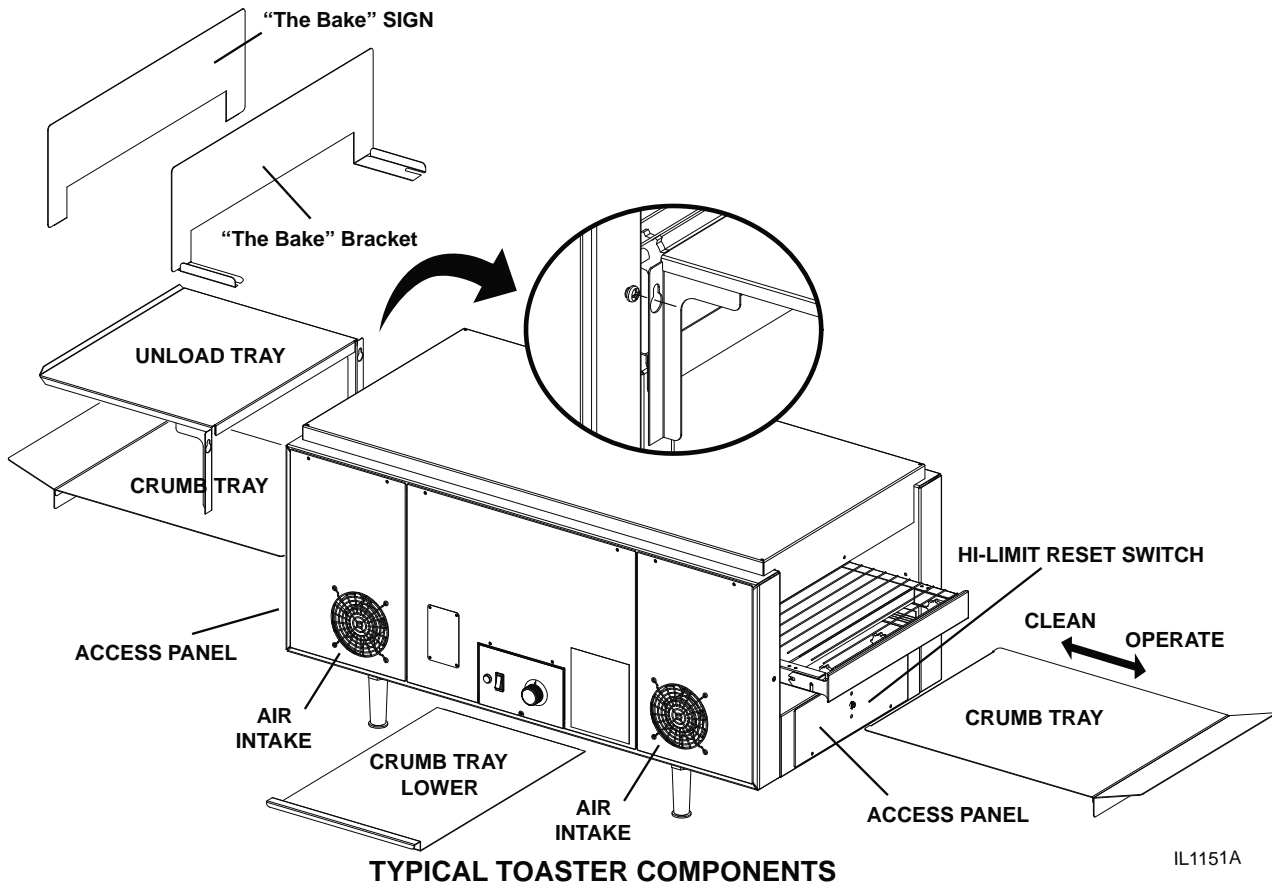

IL1151A

STACKING TOASTERS

When stacking two Holman QT14/ QT14B Conveyor Sandwich Toasters a QT14 Stacking Legs Kit (part no. PS-Z8977) **MUST** be used to prevent overheating of the control box of the top toaster.

1. Unplug **BOTH UNIT** power cords from the wall receptacle, and allow to cool.
2. Once cooled, stand the top unit on end and remove all 4 feet. *Save them for possible future use.*
3. Take one of the four (4) stacking legs and bolt it in place of previously removed leg. Tighten using wrench. Install the remaining three.
4. Stand unit in its usable position and verify the legs are stable.
5. Place the upper unit on top of the other toaster, with the controls facing the same direction and lined up together.
6. Once in place, using a #29-drill bit (.136"), drill holes into the lower toaster by going through the drill holes in the stacking leg as shown. Do this in all four (4) places.
7. Insert screws (provided) into the mounting holes securing the two units together. Continue until all four (4) are complete.
8. Plug in units and test for proper operation.

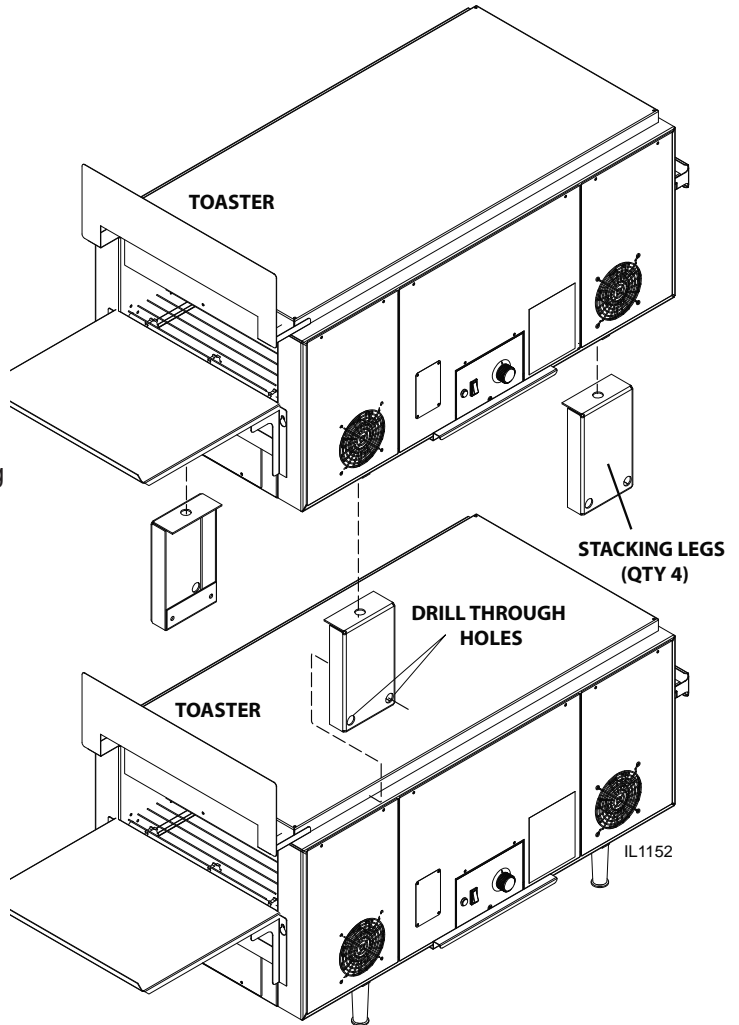

DAILY OPERATION

1. Turn On/Off switches to the ON position and variable speed control to the desired setting. Allow 30-40 minutes for complete machine warm up.
2. Adjust speed as required during operation to achieve a good bake.
3. When done for the day, turn the On/Off switch to the OFF position. The conveyor will stop and the elements will go off. The two fans will continue to run to cool the machine. The fans are controlled by a thermostat and will stop when the elements are cooled.

DO NOT begin to service or clean the machine until the fans have stopped.

CAUTION: Some parts of the machine will still be warm.

Refer to the Troubleshooting section if the machine is not performing as expected.



CERTAIN SURFACES ARE EXTREMELY HOT DURING OPERATION AND CARE SHOULD BE TAKEN WHILE USING THIS UNIT.



CLEANING

Preventive maintenance for your toaster consists of the following recommended cleaning procedures. To keep your unit in its top operating condition, these steps should be performed on a daily, weekly or as indicated.

Turn power off and allow cooling fans to run until the control box is cooled off. A thermostat in the control box controls the fans.



DISCONNECT UNIT FROM POWER SUPPLY OR TURN POWER OFF AT WALL BREAKER.

DAILY

1. Turn main power switch to the OFF position. Disconnect unit from power source and allow to cool.
2. Using a mild detergent, wipe exterior surfaces, clean with a damp cloth.
 - a. For lightly soiled build-up, clean with a damp cloth.
 - b. For heavily soiled build-up, use a soft damp cloth and mild detergent.
DO NOT use caustic cleaners.
3. Remove the unload tray by lifting it out of position. Clean using mild detergent and warm water.
4. Remove all three (3) crumb trays.
Clean crumb trays by wiping with a damp cloth and mild detergent.
DO NOT use caustic cleaners.
Place trays back in place prior to putting unit back into operation.
5. Check air intake area for dust and grease. To clean, vacuum and wipe with a dry cloth. (daily)
DO NOT spray cleaning fluids into the air intake or cooking chamber.
This may result in component failure.
6. If your unit has the glass window, carefully remove and clean the window. Remove the thumbscrews securing the window assembly. Remove the window retainer, spacer, and the piece of glass.
Wash with hot, soapy water. Reassemble.
7. Reconnect power.

THE GLASS THAT IS SUPPLIED WITH SOME OVENS IS SPECIFICALLY DESIGNED FOR IT. DO NOT SUBSTITUTE ANY OTHER GLASS PRODUCTS IN ITS PLACE.

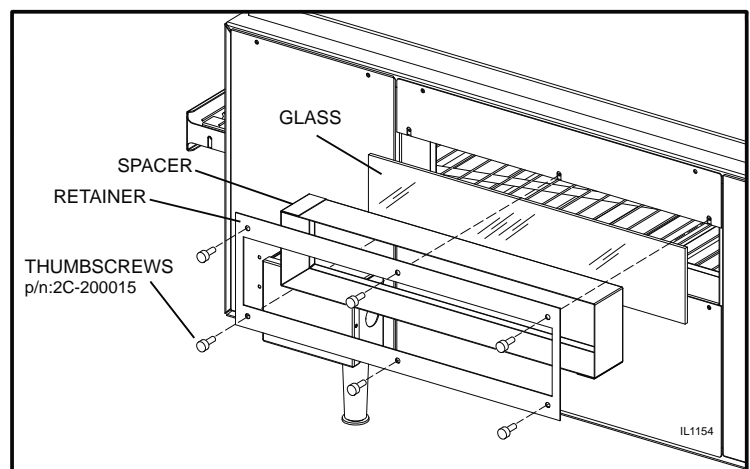

Toaster Window Access (certain units)



NEVER OPERATE THE OVEN WITHOUT THE GLASS. NEVER ATTEMPT TO TOUCH OR REMOVE THE GLASS WHILE THE OVEN IS HOT. ALLOW THE OVEN TO COOL FOR SEVERAL HOURS BEFORE STARTING THE CLEANING PROCEDURE.

CLEANING continued

WEEKLY

1. Turn main Power switch to the **OFF** position. Disconnect unit from power source and allow to cool.
2. Perform daily cleaning procedures.
3. Using a damp cloth, wipe clean the fan guard located on the control box cover under the unit.

CONVEYOR BELT CLEANING PROCEDURES

4. Reconnect power or turn power back on.
5. Switch the ON/OFF switch to the ON position, and turn conveyor to its fastest setting.
6. With the conveyor turned on and the crumb trays in place, take a wire grill brush or dry abrasive pad, clean the exposed surface of conveyor belt by passing the brush or pad, back and forth across the surface of the conveyor belt as the belt moves past. continue until the entire belt is clean. Make sure the crumb tray is installed; this will minimize the amount of particles that fall into the toaster.
7. When the Conveyor Belt is clean, take a damp cloth and wipe the conveyor, removing any loose particles on the belt surface. Turn Conveyor OFF.
8. Remove the Crumb Trays by sliding out from beneath the conveyor belt and discard soiled aluminum foil. If cleaning is necessary, use a damp cloth and mild detergent.
DO NOT use caustic cleaners.
DO NOT RUN CONVEYOR OVEN WITHOUT CRUMB TRAYS INSTALLED.
9. Cover crumb trays with clean aluminum foil and put back to its correct position.

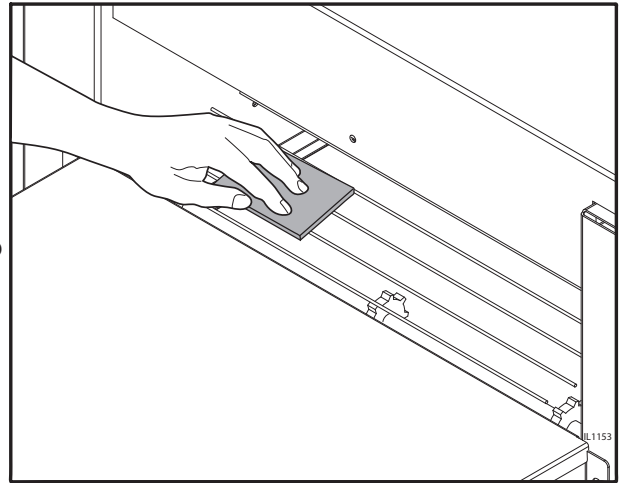

DO NOT IMMERSE OR LET THE UNIT STAND IN WATER.

DO NOT HOSE DOWN THE UNIT OR THE TABLE/COUNTER IF THE UNIT IS ON THE TABLE/COUNTER.



WARNING KEEP AWAY FROM RUNNING WATER.

CLEANING continued

MONTHLY

1. Turn power switch to the OFF position. Disconnect unit from power source and allow to cool.
2. Perform daily & weekly cleaning procedures.
3. Working from the power supply side of the oven, locate the side panel, remove two screws holding panel in place and remove panel. Drive chain is now exposed.
4. Check drive chain tension.
 - a. When properly adjusted, chain will have about 1/8" play but will not sag.
See Chain Tension Illustration on page 12.
 - b. To adjust drive chain tension, locate the drive motor mounting screws (see illustration). Loosen screws holding drive motor in place and slide drive motor forward or backward to adjust chain tension. With proper chain tension, retighten motor screws.
 - c. Following the procedures on page 12, Lubricate drive chain and sprocket teeth with a high temp lubricant part no. **1P-Z8914**.

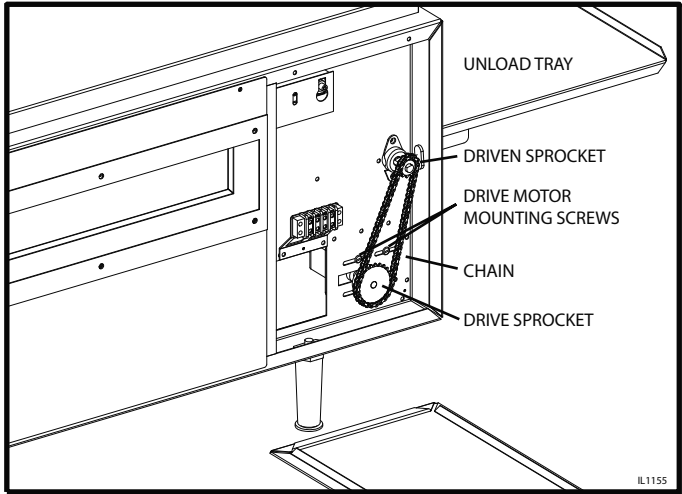

5. Clean air intake on the side of the unit by vacuuming any dust and debris built up on the fan grill.
6. Remove screws holding the control side panels in place (as shown below). Carefully lift panel up and out. Vacuum any dust and debris from inside the unit, being sure to clean the fan blades and inside of unit, repeat opposite side.
7. Replace all panels when completed. **CHECK NO WIRES GET PINCHED AS THE PANELS ARE REPLACED. ALSO, CHECK ANY WIRES AROUND THE MOTOR TO MAKE SURE THEY DO NOT INTERFERE WITH THE SPROCKETS.**
8. For exterior portions of unit that are heavily soiled, an abrasive pad may be used for cleaning. Be sure to pass the pad in the direction of the grain in the metal to maintain the surface's finish. Lightly soiled surfaces may be cleaned with a damp cloth and mild cleaner.

9. Reconnect unit to power supply and test for proper operation.

IF ASSISTANCE IS REQUIRED, CALL THE STAR SERVICE HELP DESK AT 1-800-807-9054.

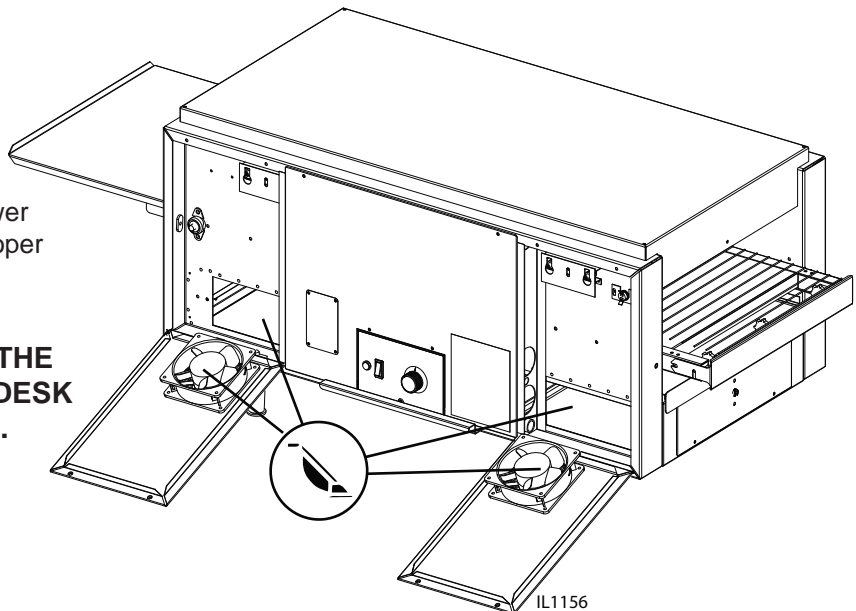

MAINTENANCE & REPAIRS

A. REPLACING ELEMENT

NOTE: Replace one element at a time.

- 1) **DISCONNECT POWER SOURCE.**
- 2) Remove both the left and right side panels, by removing the truss head screws. Pull the top of each panel out slightly and lift up.
- 3) Remove element wires which are requiring replacement from its terminal block connection.
- 4) Loosen the Element Retainer and move it upward and tighten.
- 5) Gently, pull defective element out of unit.
- 6) Slide slipping straws on the element wires for an easier installation. Guiding the wire & element into position
- 7) Connect wires to the terminal blocks and tug lightly on the wire to ensure good connection.
- 8) Loosen screw(s) holding the retainer secure and slide it back into position, to secure element in place.
- 9) Install each side panel
- 10) Connect unit to power source and test unit for proper operation.

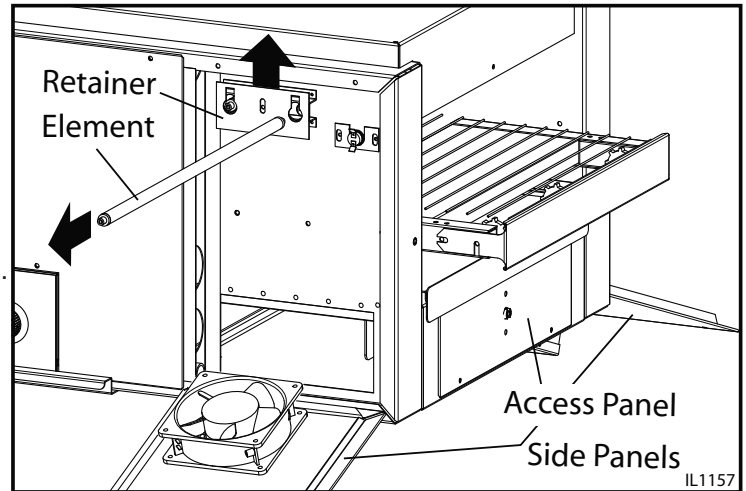

B. REPLACING FAN MOTOR

- 1) **DISCONNECT POWER SOURCE.**
- 2) Remove the side panel with the fan that needs replaced.
- 3) Unplug power supply cord from fan motor.
- 4) Remove (4) screws, which hold fan motor and grill to the side panel and remove fan.
- 5) Put replacement motor and grill in place and secure to the side panel with screws previously removed.
- 6) Reconnect power supply cord to fan motor.
- 7) Replace back panel and enclosure. Fasten with screws removed in step 2, being sure to keep wires away from the fan motor.
- 8) Connect unit to power source and test unit for proper operation.

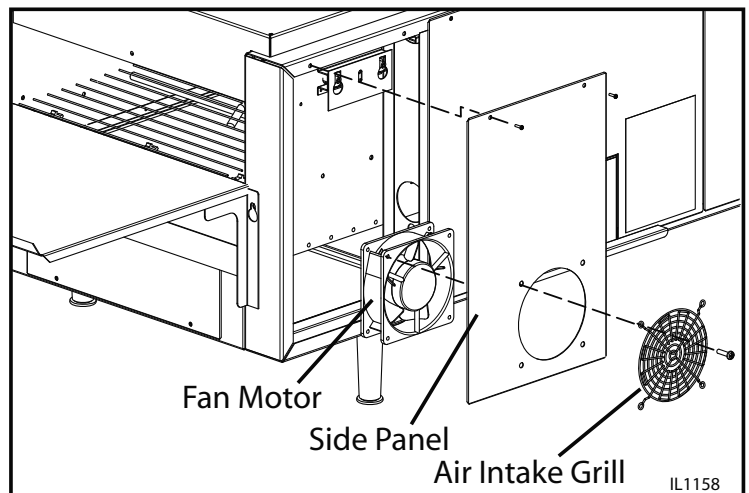

C. REPLACING BELT DRIVE MOTOR

- 1) **DISCONNECT POWER SOURCE.**
- 2) Remove the side panel & access panel exposing the drive chain, sprockets & drive motor
- 3) Remove sprocket from motor shaft, using an Allen wrench and loosening the set-screw.
- 4) Remove the wires from terminal block connecting the drive motor.

Note how the old motor is wired for replacement. For reference, use the black and white wires for 208V units and the black and blue wires for 240V units. The unused wire should be taped on the end and bundled with the existing wires so it will not get tangled in any moving parts.

- 5) Remove screws holding motor in place and remove motor from unit.
- 6) Install the new motor in place and attach loosely with mounting screws.

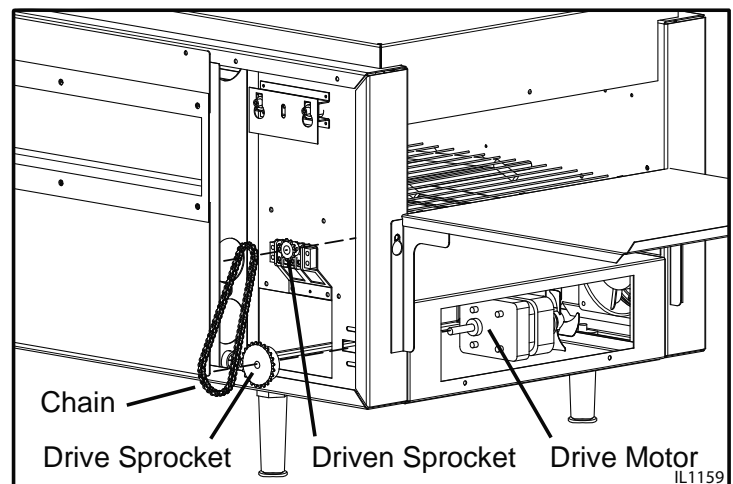

MAINTENANCE PROCEDURES continued

- 7) Install sprocket on motor shaft & chain after aligning them.
See *Sprocket Alignment Illustration*.

NOTE: The two sprockets must line up FLUSH with each other, so the chain does not twist during operation. Also the hub is installed closest to the motor.

- 8) Slide motor until the drive chain has about 1/4" slack when lightly pushed at the center of its top open run.
See *Chain Tension Illustration*.
- 9) Tighten screws to secure motor.
- 10) Rewire leads same as removed in step 4.
- 11) At this time you may plug unit in and test for proper operation prior to reinstalling previously removed panels.
- 12) If unit is working correctly, turn unit off and unplug until completed
- 13) Reinstall side & access panels.
Reinstall the crumb trays.
- 14) Connect unit to power source and test again for proper operation.

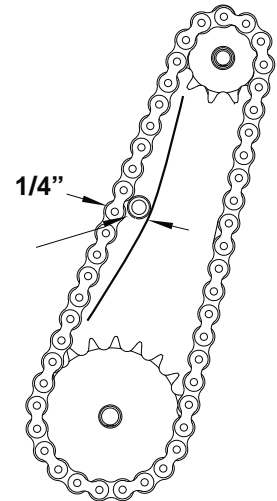

CHAIN TENSION

D. LUBRICATE THE CHAIN & SPROCKETS EVERY 6 MONTHS

- 1) **DISCONNECT UNIT FROM POWER SOURCE.**
- 2) Remove the side panels which exposes chain drive.
- 3) Check for proper Chain Tension, See *Chain Tension Illustration*.
- 4) Using an extreme pressure, synthetic chain lubricant with a temperature range up to 400°F.
Apply liberally onto chain and sprockets.
This grease is available separately as part no. **1P-Z8914**.

Call 1-(800) 807-9054 to order.

- 5) Replace side panels, Reconnect power source and test unit.

E. REPLACING SPEED CONTROL

- 1) **DISCONNECT POWER SOURCE.**
- 2) Remove the speed control knob and the locking nut holding the speed control in place.
- 3) Remove side panel, by removing the truss head screws. Pull the top of the panel out slightly and lift up.
- 4) Remove the wires from the control and insert wires for the new speed control into the same positions as shown on the wiring diagram.
- 5) Install the washer onto the shaft of the new speed control, followed by the installation.
- 6) When mounting the speed control in the side panel be sure to position the anti-rotation pin in the slot as shown.
- 7) Tighten the speed control assembly by using the locking nut, followed by the control knob.
- 8) Reinstall the side panel and tighten with the screws previously removed.
- 9) Connect unit to power source and test unit for proper operation.

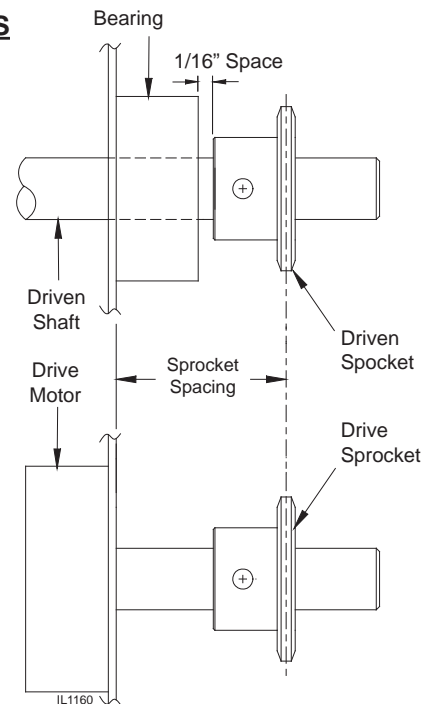

SPROCKET ALIGNMENT

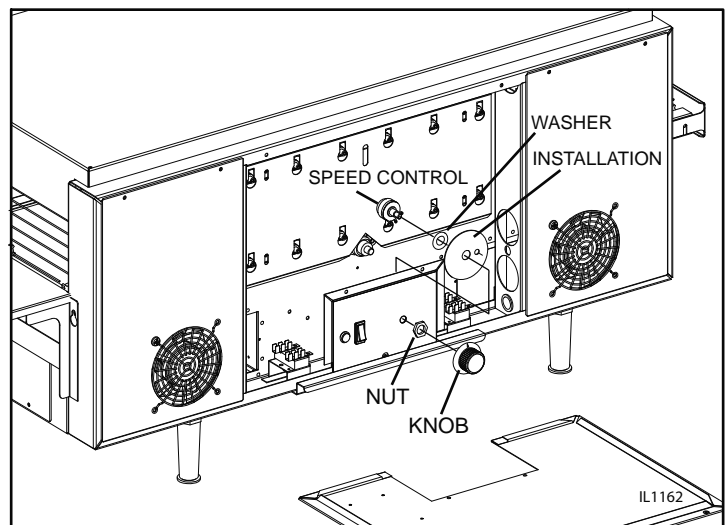

REPLACING SPEED CONTROL

TROUBLESHOOTING GUIDE

A. UNIT WILL NOT HEAT, CONVEYOR BELT WILL NOT MOVE.

- 1) Be sure the main circuit breaker is switched to the ON position and there is power to the outlet.
- 2) Check to see if the toaster is plugged in and all controls are turned to the ON position.
- 3) Be sure the Hi-Limit Reset Button is pushed in.
- 4) Call the Star Service Help Desk at 1-800-807-9054.

B. UNIT WILL NOT HEAT, CONVEYOR TURNS PROPERLY.

- 1) Check to see if the heat controls have been turned to the maximum setting.
- 2) Press the Hi-Limit Reset Button located on the end under the conveyor belt.
If this reactivates the heater tubes, see Hi-Limit Reset Section below.
- 3) Call the Star Service Help Desk at 1-800-807-9054.

C. HI-LIMIT (HEAT) RESET.

Your Holman conveyor toaster is equipped with an automatic activated temperature limit switch which interrupts the heater tube connections if the air temperature in the control box exceeds 190°F (88°C). This limit switch can be reset manually by pushing the button in the center of the switch which is located on the right side under the conveyor belt. See Oven Components on Page 7 for location. Unit will not reset until internal temperature has fallen below 190°F (88°C).

NOTE: THE HI-LIMIT SWITCH CAN BE ACTIVATED IF THERE IS NOT A PROPER AMOUNT OF AIR FLOW BEING GENERATED BY THE COOLING FAN. IF THIS OCCURS:

- 1) **DISCONNECT UNIT FROM POWER SOURCE.**
- 2) Check to see if the air intake area is free of dust, grease or other obstructions.
- 3) Check to see if crumb trays (heat reflectors) are in place.
If the Hi-Limit Switch can not be reset, call the Star Service Help Desk at 1-800-807-9054.



NEVER OPERATE UNIT WITHOUT CRUMB TRAYS IN POSITION AS THIS CAUSES OVERHEATING IN THE CONTROL BOX.

D. CONVEYOR WILL NOT TURN, UNIT HEATS PROPERLY.

To check for mechanical binding:

- 1) **DISCONNECT UNIT FROM POWER SOURCE.**
- 2) Check to see if there are obstructions in the conveyor system that may cause a jam. If so, remove obstruction.
- 3) Check power supply & terminal blocks for loose or disconnected wires.
- 4) Check to see if the two sprockets are properly aligned. Refer to **SPROCKET ALIGNMENT** previous section.
- 5) Remove side panel exposing the drive motor sprockets, see illustration. Manually move conveyor belt to check for mechanical binding. If conveyor belt moves freely, call the Star Service Help Desk at 1-800-807-9054. The drive motor or speed control may have to be replaced.

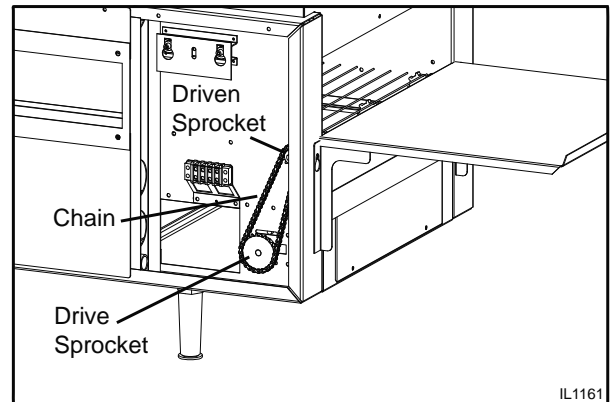

E. COOLING FAN DOES NOT START

- 1) Check fan blade for obstruction, or broken blades.
- 2) Check electrical connections are secure and complete & the Hi-Limit Switch is working properly.
- 3) If only one of the two fans are working, and all connections are good, replace the fan.
Refer to **REPLACING FAN MOTOR** in the previous section.
- 4) If both fans are not working, chances are the fan switch needs replacing.
- 3) Call the Star Service Help Desk at 1-800-807-9054, as the fan switch and or fan motor **MAY** need replacing.

THOROUGHLY INSPECT YOUR UNIT ON ARRIVAL

This unit has been tested for proper operation before leaving our plant to insure delivery of your unit in perfect condition. However, there are instances in which the unit may be damaged in transit. In the event you discover any type of damage to your product upon receipt, you must immediately contact the transportation company who delivered the item to you and initiate your claim with same. If this procedure is not followed, it may affect the warranty status of the unit.

LIMITED EQUIPMENT WARRANTY

All workmanship and material in Star products have a one (1) year limited warranty on parts & labor in the United States and Canada. Such warranty is limited to the original purchaser only and shall be effective from the date the equipment is placed in service. Star's obligation under this warranty is limited to the repair of defects without charge, by the factory authorized service agency or one of its sub-agencies. Models that are considered portable (*see below*) should be taken to the closest Star service agency, transportation prepaid.

- > Star will not assume any responsibility for loss of revenue.
- > On all shipments outside the United States and Canada, see International Warranty.
- * The warranty period for the JetStar six (6) ounce & Super JetStar eight (8) ounce series popcorn machines is two (2) years.
- * The warranty period for the Chrome-Max Griddles is five (5) years on the griddle surface. See detailed warranty provided with unit.
- * The warranty period for Teflon/Dura-Tec coatings is one year under normal use and reasonable care. This warranty does not apply if damage occurs to Teflon/Dura-Tec coatings from improper cleaning, maintenance, use of metallic utensils, or abrasive cleaners, abrasive pads, product identifiers and point-of-sale attachments, or any other non-food object that comes in continuous contact with the roller coating. This warranty does not apply to the "non-stick" properties of such materials.
- > This warranty does not apply to "Special Products" but to regular catalog items only. Star's warranty on "Special Products" is six (6) months on parts and ninety (90) days on labor.
- > This warranty does not apply to any item that is disassembled or tampered with for any purpose other than repair by a Star Authorized Service Center or the Service Center's sub-agency.
- > This warranty does not apply if damage occurs from improper installation, misuse, wrong voltage, wrong gas or operated contrary to the Installation and Operating instructions.
- > This warranty is not valid on Conveyor Ovens *unless* a "start-up/check-out" has been performed by a Factory Authorized Technician.

PARTS WARRANTY

Parts that are sold to repair out of warranty equipment are warranted for ninety (90) days. The part only is warranted. Labor to replace the part is chargeable to the customer.

SERVICES NOT COVERED BY WARRANTY

1. Travel time and mileage rendered beyond the 50 mile radius limit
2. Mileage and travel time on portable equipment (*see below*)
3. Labor to replace such items that can be replaced easily during a daily cleaning routine, ie; removable kettles on fryers, knobs, grease drawers on griddles, etc.
4. Installation of equipment
5. Damages due to improper installation
6. Damages from abuse or misuse
7. Operated contrary to the Operating and Installation Instructions
8. Cleaning of equipment
9. Seasoning of griddle plates
10. Voltage conversions
11. Gas conversions
12. Pilot light adjustment
13. Miscellaneous adjustments
14. Thermostat calibration and by-pass adjustment
15. Resetting of circuit breakers or safety controls or reset buttons
16. Replacement of bulbs
17. Replacement of fuses
18. Repair of damage created during transit, delivery, & installation OR created by acts of God

PORTABLE EQUIPMENT

Star will not honor service bills that include travel time and mileage charges for servicing any products considered "Portable" including items listed below. These products should be taken to the Service Agency for repair:

- * The Model 510FD Fryer.
- * The Model 526TOA Toaster Oven.
- * The Model J4R, 4 oz. Popcorn Machine.
- * The Model 518CMA & 526CMA Cheese Melter.
- * The Model 12MC & 15MC & 18MCP Hot Food Merchandisers.
- * The Model 12NCPW & 15NCPW Nacho Chip/Popcorn Warmer.
- * All Hot Dog Equipment **except Roller Grills & Drawer Bun Warmers.**
- * All Nacho Cheese Warmers **except Model 11WLA Series Nacho Cheese Warmer.**
- * All Condiment Dispensers **except the Model HPD & SPD Series Dispenser.**
- * All Specialty Food Warmers **except Model 130R, 11RW Series, and 11WSA Series.**
- * All QCS/RCS Series Toasters **except Model QCS3 & RCS3 Series.**
- * All Fast Steamer Models **except Direct Connect Series.**

ALL:

- * Pop-Up Toasters
- * Butter Dispensers
- * Pretzel Merchandisers
(Model 16PD-A Only)
- * Pastry Display Cabinets
- * Nacho Chip Merchandisers
- * Accessories of any kind
- * Sneeze Guards
- * Pizza Ovens
(Model PO12 Only)
- * Heat Lamps
- * Pumps-Manual

The foregoing warranty is in lieu of any and all other warranties expressed or implied and constitutes the entire warranty.

FOR ASSISTANCE

Should you need any assistance regarding the Operation or Maintenance of any Star equipment; write, phone, fax or email our Service Department. In all correspondence mention the Model number and the Serial number of your unit, and the voltage or type of gas you are using.

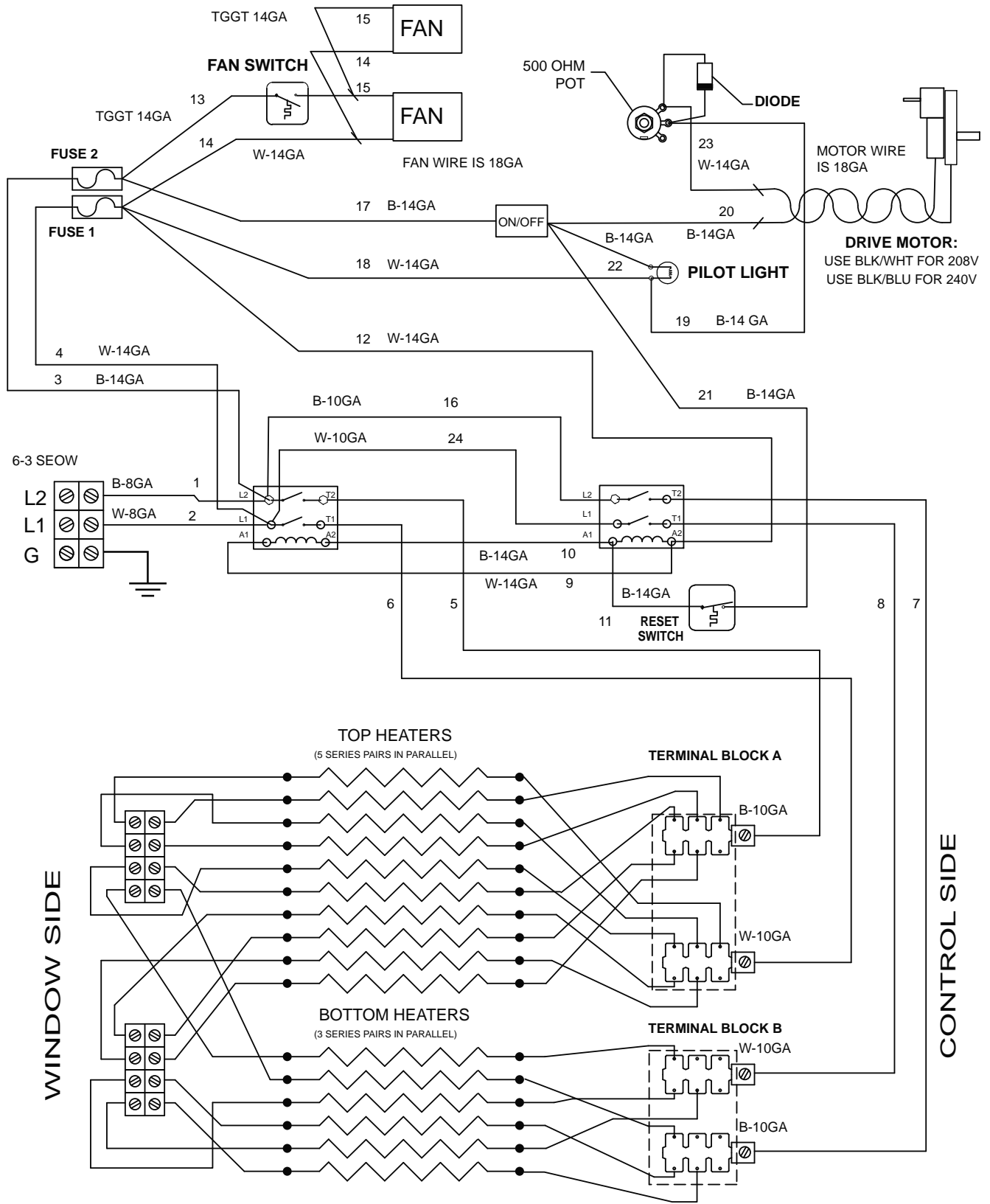

THIS DRAWING CONTAINS INFORMATION CONFIDENTIAL TO STAR MFG. INT'L. INC.
NO REPRODUCTION OR DISCLOSURE OF ITS CONTENTS IS PERMITTED.



MODEL: QT14B-Window, 208/220/240V, 1Phase
w/Potentiometer Speed Control

STAR MANUFACTURING INTERNATIONAL INC.

SK2185

Rev -

6/05/2006

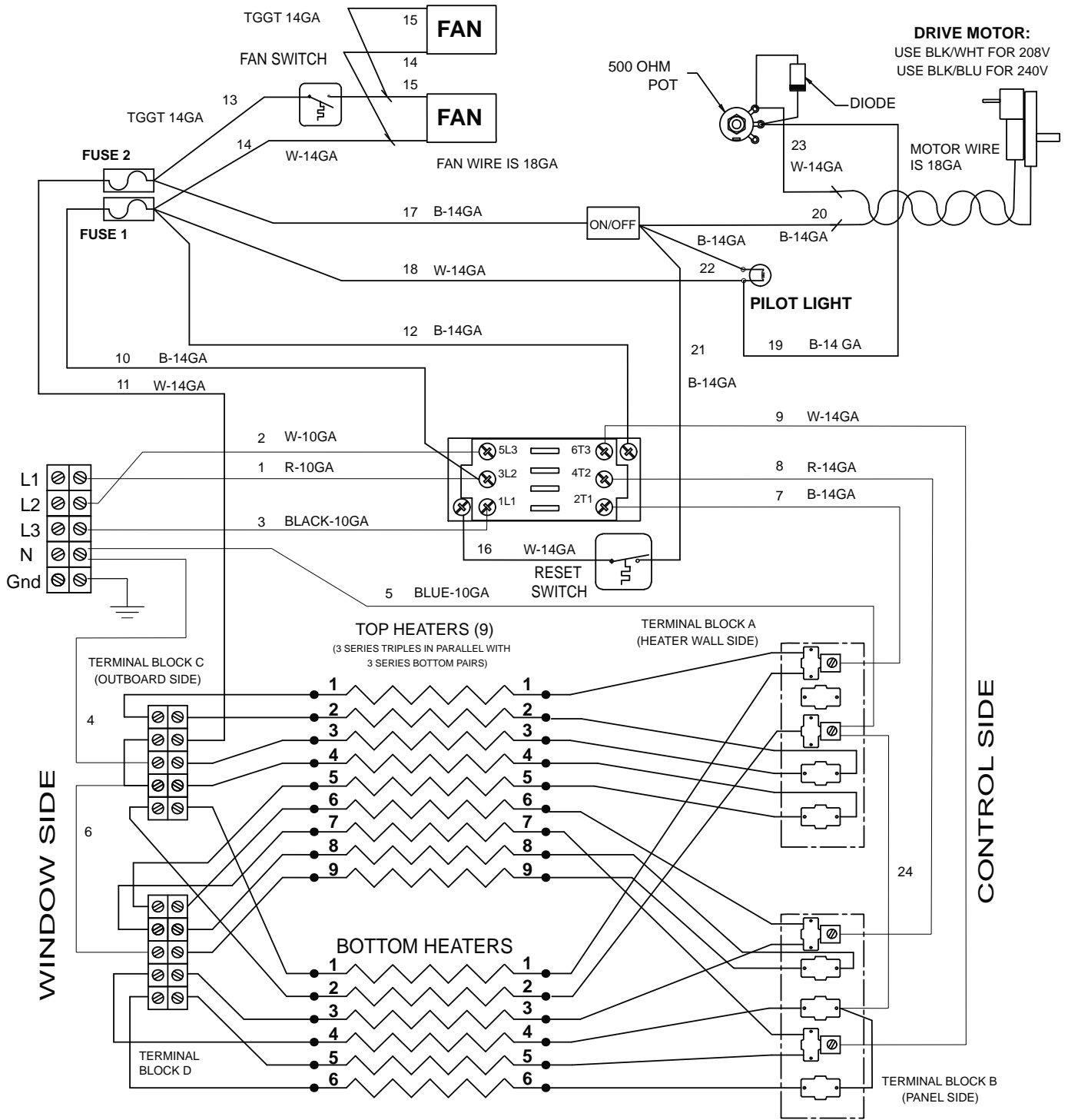

THIS DRAWING CONTAINS INFORMATION CONFIDENTIAL TO STAR MFG. INT'L. INC.
NO REPRODUCTION OR DISCLOSURE OF ITS CONTENTS IS PERMITTED.

MODEL: QT14, 3 Phase Y



SK2193 Rev - 2/06/2006

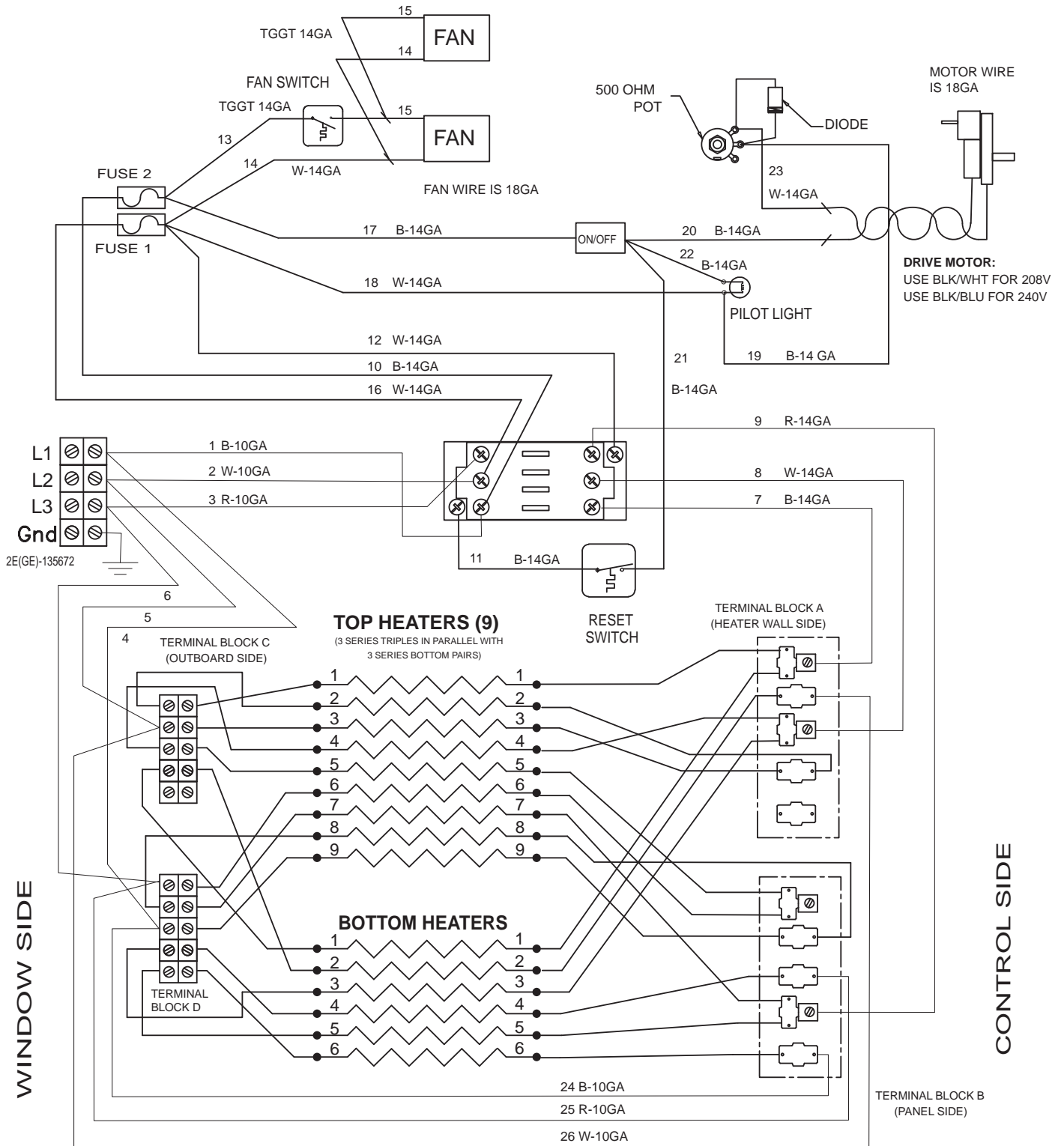

THIS DRAWING CONTAINS INFORMATION CONFIDENTIAL TO STAR MFG. INT'L. INC.
 NO REPRODUCTION OR DISCLOSURE OF ITS CONTENTS IS PERMITTED.



MODEL: QT14, 3 Phase Delta - POT Control

SK2194 Rev A 8/07/2006

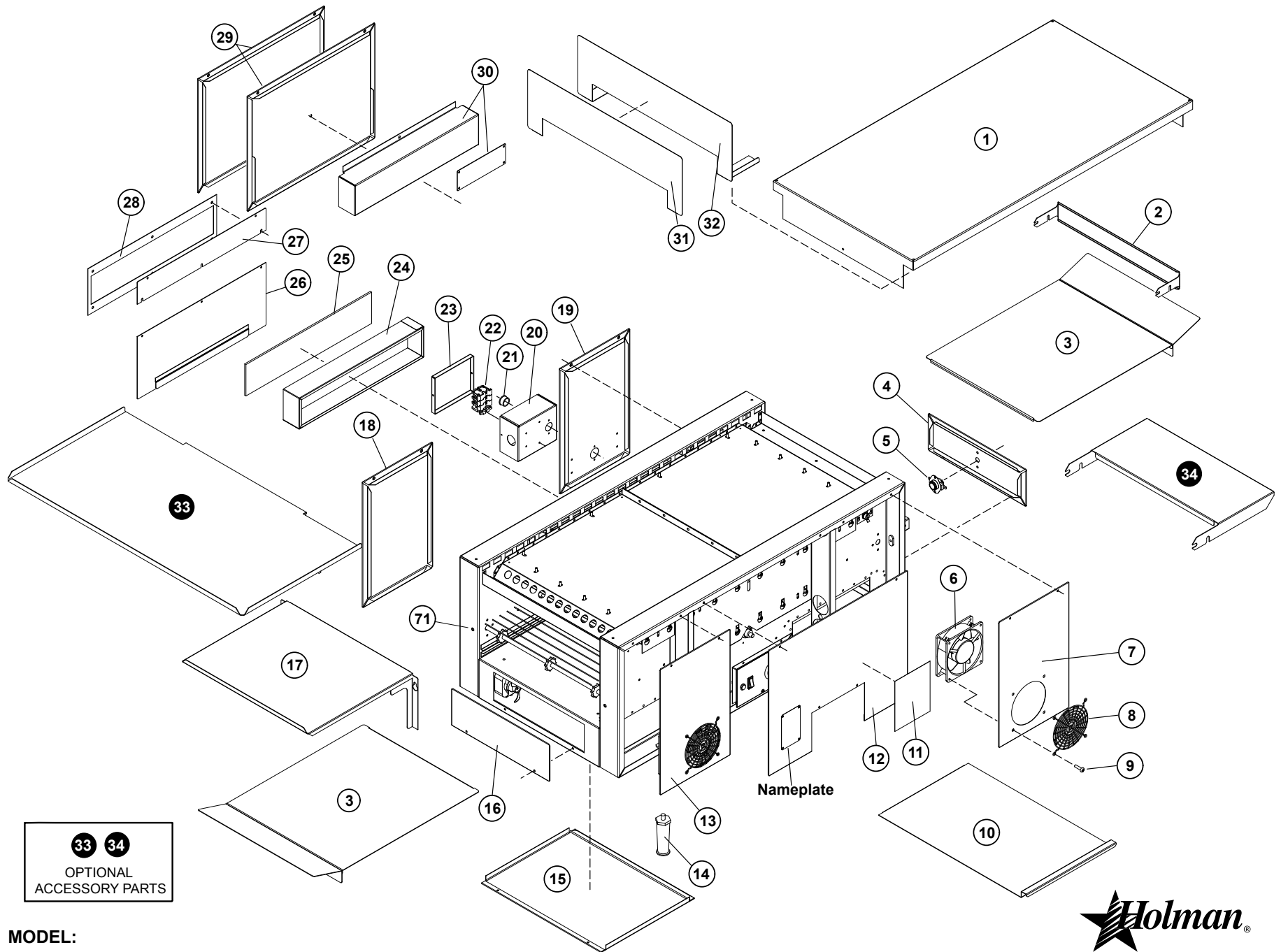

MODEL:
QT14B



SK2186 Rev. E 3/25/13



QT14B Holman Conveyor Toaster

Fig No.	Part Number	Quantity Per	Description	Fig No.	Part Number	Quantity Per	Description	
1	GE-100991	1	TOP COVER	19	GE-Z9636	1	PANEL - POWER INPUT	
2	GE-402610	1	CONVEYOR END GUARD	20	GE-402709	1	ELECTRICAL BOX (POWER INPUT)	
3	GE120303	2	CRUMB TRAY	21	2K-200464	5	BUSHING, WIRE RING 7/8"	
4	GE-Z9594	1	PANEL, CONTACTOR SIDE w/RESET	22	SP-115402	1	TERMINAL BLOCK - MAIN POWER	
5	2E-200566	1	SWITCH, OVERTEMP (RESET)	23	GE-402710	1	ELECTRICAL BOX COVER	
6	2U-200577	2	COOLING FAN - 240V HIGH OUTPUT	24	GE-101390	1	WINDOW SPACER	
7	GE-Z9598	1	PANEL - FAN OFFSET RIGHT	25	2Q-200588	1	WINDOW - NEO SARAMA	
8	2R-Z16753	1	FAN GUARD - COOLING FAN	26	GE-101028	1	PANEL - LOWER BACK	
9	2C-Z5883	8	SCREW, 10-24 X 1/2" FZA SELF DRILLING	27	GE-402689	1	PANEL - UPPER BACK	
10	GE-402654	1	CRUMB TRAY - LOWER	28	GE-402631	1	WINDOW RETAINER - OUTSIDE	
11	2M-Z9631	1	LABEL, QUIZNOS	29	GE-Z10172	1	WINDOW BLANKOFF SIDE PANEL	
12	GE-Z9596	1	PANEL - CONTROL SIDE		GE-Z9911	1	SIDE PANEL, CENTER PLAIN	
13	GE-Z9597	1	PANEL - FAN OFFSET LEFT				<i>Serial No. COQT0507B0001-20, 31-40 and above</i>	
14	2A-Z0314	4	LEG - 4"	30	GE-Z10173	1	WINDOW BLANKOFF BOX	
15	GE-Z9633	2	CONTROL BOX COVER		GE-Z9902	1	ACCESS COVER PLATE	
16	GE-Z9593	1	PANEL, MOTOR SIDE				<i>Serial No. COQT0507B0001-20, 31-40 and above</i>	
17	GE-100944	1	UNLOAD TRAY	31	2M-200816	1	BAKE AID MAGNET	
18	GE-Z9635	1	PANEL - PLAIN SIDE	32	GE-402729	1	BAKE AID BRACKET	
				71	2C-Z10075	2	SCREWM 1/4-20 X 3/8 (holds Exit Tray) use 2C-Z10076 Steel Spacer also	
				ACCESSORIES				
				33	QTEXT14	-	EXIT SHELF FOR QT14 QUIZNO'S - 14 X 28	
				34	QTEXTY7	-	ENTRY SHELF FOR QT14 QUIZNO'S	
				NI	2E-Z9567	2	FAN CORD	
				NI	2E-200573	1	CONTRACTOR/RELAY - 3 PHASE OVENS	
				NI	2E-Z9782	2	TERMINAL BLOCK - ESE2	3 PHASE

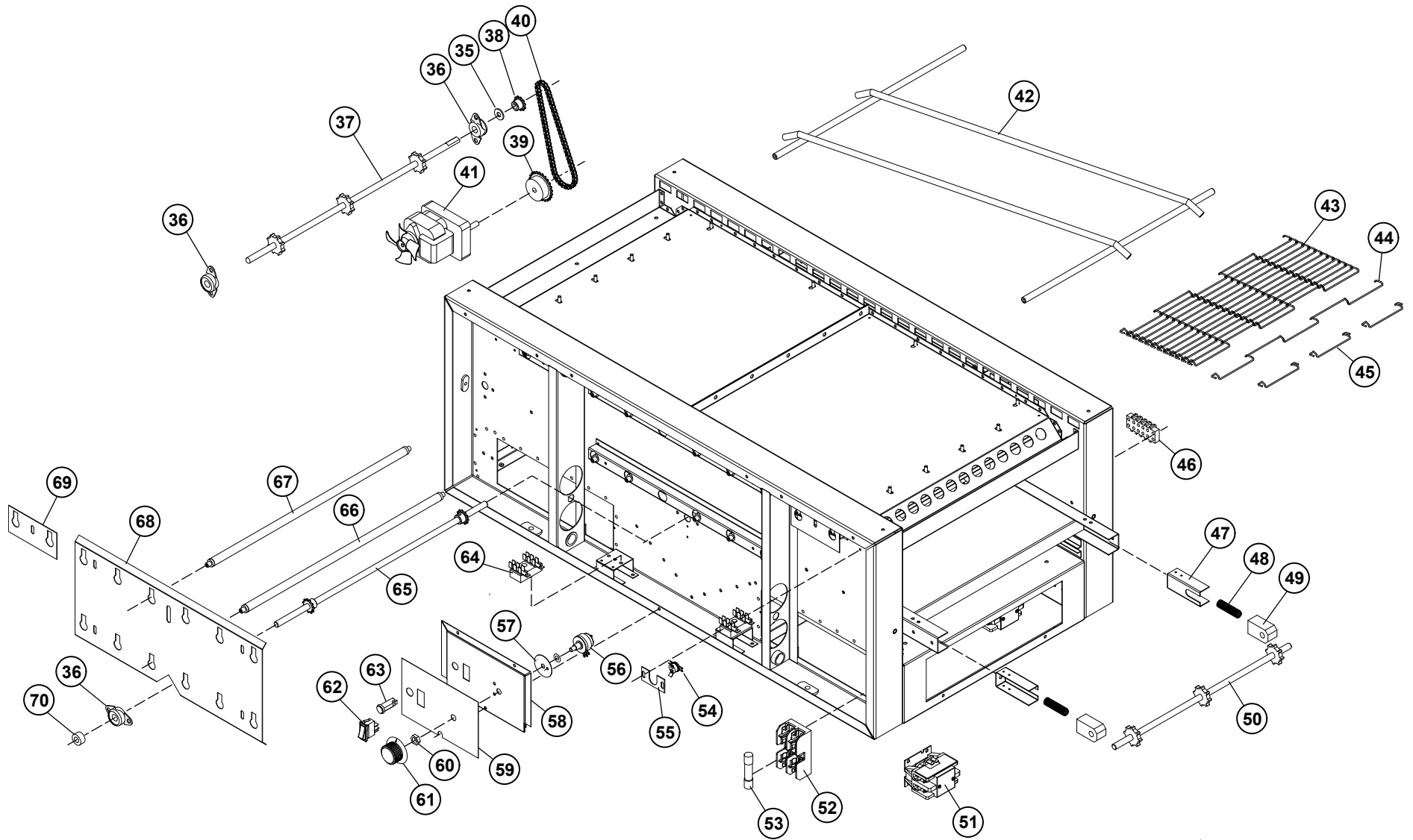

MODEL:
QT14B



QT14B Holman Conveyor Toaster

Fig No.	Part Number	Quantity Per	Description	Fig No.	Part Number	Quantity Per	Description
35	2C-200150	1	WASHER, 3/8"	51	2E-Z8966	2	CONTACTOR/RELAY - 1 PHASE
36	GB-112262	4	BEARING ASSY. 3/8" FLANGED		PS-Z14660	1	CONTACTOR 50A 3 PHASE
37	GE-101254	1	DRIVE SHAFT ASSY (W/SPROCKETS)	52	2E-200597	1	FUSEHOLDER - 2 POSITION, TYPE G
38	2P-200652	1	SPROCKET DRIVEN -17 tooth 3/8 after COQT0307B0001	53	2E-Z8405	2	FUSE - 15A TYPE G
	2P-115362	1	SPROCKET DRIVEN -11 tooth 3/8 before COQT0301B001	54	2E-200574	1	SWITCH, FAN (COOLDOWN)
39	2P-200646	1	SPROCKET DRIVE - 20 tooth 5/16 after COQT0301B0001	55	HG-402144	1	BRACKET, FAN SWITCH
	2P-200650	1	SPROCKET DRIVE -24 tooth 5/16 before COQT0301B001	56	GE-Z9359	1	SPEED CONTROL POTENETIOMETER (500 OHM)
40	2P-150000	1	QT14 DRIVE CHAIN #25	57	2E-200180	1	INSULATION, SWITCH, POTENEIOMETER
41	PS-Z10285	1	CONVEYOR MOTOR LEFT TO RIGHT 50/60Hz	59	GE-Z9595	1	PANEL, FRONT CONTROL w/SWITCHES
	PS-Z10286	1	CONVEYOR MOTOR RIGHT TO LEFT 50/60Hz	59	2M-Z9630	1	LABEL, MAIN CONTROL
PS-Z10285 INCLUDES:			<i>s/n COQT0307B0001 or after order parts separately</i>	60		1	NUT, 3/8"-32 NEF, COMES WITH FIG. NO 52
	2U-Z9658	1	MOTOR AC 11 RPM CCW, L - R	61	2R-200761	1	KNOB, SPEED CONTROL
	2P-200652	1	SPROCKET DRIVEN -17 tooth 3/8"	62	2E-Z9592	1	SWITCH, MAIN ON/OFF
	2P-200646	1	SPROCKET DRIVE - 20 tooth 5/16"	63	2J-Z2329	1	PILOT LIGHT - RED
	2C-Z10075	1	SCREW - 1/4-20X3/8	64	2E-Z9571	2	TERMINAL BLOCK - 12 POSITION
	2A-Z10161	1	SPACER-STEEL	65	2A-101257	1	RETURN SHAFT ASSY (W/SPROCKETS)
	2M-Z10161	1	INSTRUCTIONS - QT14 DRIVE MOTOR REPLAC.	66	GE-198102	6	HEATER TUBE, 675W 208V BOTTOM, 1PH & 3PH
PS-Z10286 INCLUDES:			<i>s/n COQT0307B0001 or after order parts separately</i>		GE-198104	6	HEATER TUBE, 675W 240V BOTTOM, 1PH
	2U-Z9657	1	MOTOR AC 11 RPM CW, R - L		GE-198106	6	HEATER TUBE, 700W 220V BOTTOM, 1PH & 3PH
	2P-200652	1	SPROCKET DRIVEN -17 tooth 3/8"	67	GE-198103	10	HEATER TUBE, 375W 208V TOP, 1PH
	2P-200646	1	SPROCKET DRIVE - 20 tooth 5/16"		GE-198105	10	HEATER TUBE, 375W 240V TOP, 1PH
	2C-Z10075	1	SCREW - 1/4-20X3/8		GE-198107	10	HEATER TUBE, 375W 220V TOP, 1PH
	2A-Z10161	1	SPACER-STEEL		GE-198108	9	HEATER TUBE, 417W 380V TOP, 3PH
	2M-Z10161	1	INSTRUCTIONS - QT14 DRIVE MOTOR REPLAC.		GE-198109	9	HEATER TUBE, 417W 208V TOP, 3PH
NI	2R-200721	1	FAN BLADE - CONVEYOR MOTOR L-R		GE-198113	9	HEATER TUBE, 400W 80V 415V, TOP 3-Y PHASE
NI	2R-Z8879	1	FAN BLADE - CONVEYOR MOTOR R-L	68	GE-402359	1	HEATER TUBE RETAINER - LARGE
42	GE-100715	1	BELT SUPPORT	69	GE-402651	2	HEATER TUBE RETAINER - SMALL
43	GE-160031	1	CONVEYOR BELT W/ 3 LINKS - 82.5" LONG	70	2A-200672	3	SHAFT COLLAR - 3/8"
44	2B-200618	1	CONVEYOR BELT LINK, 14"	NI	PS-101595	1	HEATER TUBE KIT (ALL 16) 208V
45	2B-200620	3	CONVEYOR BELT SINGLE SPACE CLIP	NI	PS-101596	1	HEATER TUBE KIT (ALL 16) 240V
46	2E-Z9570	2	TERMINAL BLOCK - 4 POS.	NI	PS-Z8977	1	STACKING KIT
	2E-Z9781	2	TERMINAL BLOCK - 5 POS.	NI	2E-Z9567	2	FAN CORD
47	GE-402574	2	BEARING HOLDER	NI	2E-200573	1	CONTRACTOR/RELAY - 3 PHASE OVENS
48	2P-200766	2	SPRING, BEARING	NI	2E-Z9782	2	TERMINAL BLOCK - ESE2 3 PH
49	2P-200785	2	BEARING, SPRING LOADED	NI	1P-Z8914	1	EXTREME PRESSURE MULTIPURPOSE SYNTHETIC GREASE (80°F TO 400°F) , TUBE 8 oz.
50	GE-101255	1	IDLER SHAFT ASSY (W/SPROCKETS)				