

22 23
 OPTIONAL
 ACCESSORY PARTS

MODEL:
 QT14C



SK2248 Rev. - 6/1/07



QT14C Holman Conveyor Toaster

Fig No.	Part Number	Quantity Per	Description	Fig No.	Part Number	Quantity Per	Description
1	GE-100991	1	TOP COVER	15	GE-Z10091	1	PANEL, MOTOR SIDE
2	GE-402610	1	CONVEYOR END GUARD	16	GE-101593	1	UNLOAD TRAY
3	GE-Z9903	2	CRUMB TRAY	17	GE-Z9635	2	PANEL - PLAIN SIDE
4	GE-Z10092	1	PANEL, CONTACTOR SIDE w/RESET	18	GE-Z10172	1	SIDE PANEL
5	2E-200566	1	SWITCH, OVERTEMP (RESET)	19	2K-Z10097	1	90° CORD CONNECTOR
6	2U-200577	2	COOLING FAN - 240V HIGH OUTPUT	NI	2E-Z10057	1	POWER CORD
7	GE-Z9598	1	PANEL - FAN OFFSET RIGHT	20	2M-200816	1	BAKE AID MAGNET
8	2R-200562	1	FAN GUARD - COOLING FAN	21	GE-402729	1	BAKE AID BRACKET
9	2C-200048	8	SCREW, 10-24 X 1/2" SLOT HEX	ACCESSORIES			
10	2M-Z10423	1	LABEL, QUIZNOS	22	QTEXT14	-	EXIT SHELF FOR QT14 QUIZNO'S - 14 X 28
11	GE-Z9596	1	PANEL - CONTROL SIDE	23	QTEXT7	-	ENTRY SHELF FOR QT14 QUIZNO'S
12	GE-Z9597	1	PANEL - FAN OFFSET LEFT				
13	2A-Z0314	4	LEG - 4"				
14	GE-Z9900	1	BOTTOM COVER, QT14C				

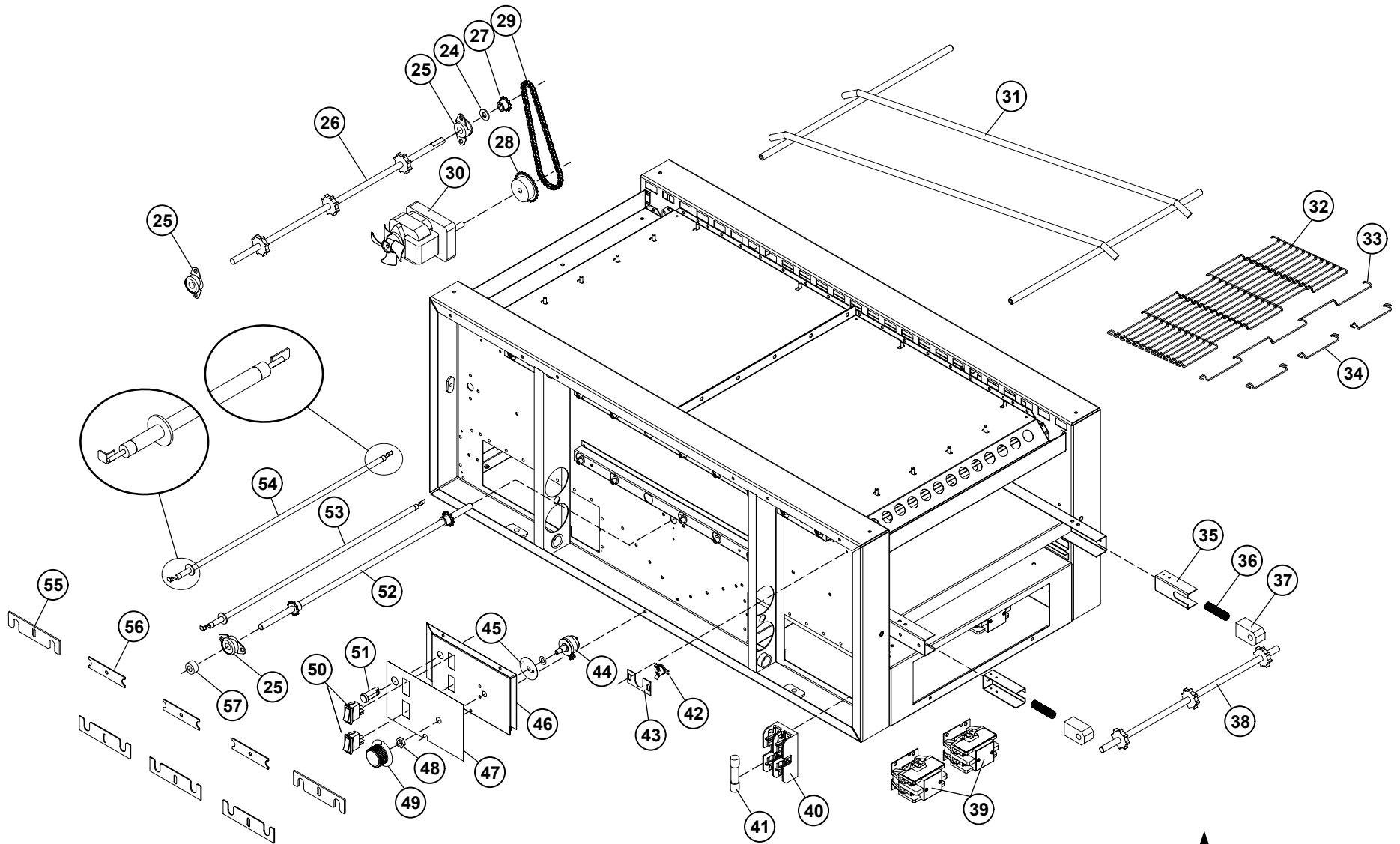

MODEL:
QT14C



SK2249 Rev. - 6/1/07



QT14C Holman Conveyor Toaster

Fig No.	Part Number	Quantity Per	Description	Fig No.	Part Number	Quantity Per	Description
24	2C-200150	1	WASHER, 3/8"	53	2N-Z9913	10	HTR ELEMENT, 425W, 104V, TOP, METAL 208V
25	GB-112262	4	BEARING ASSY. 3/8" FLANGED		2N-Z9915	10	HTR ELEMENT, 425W, 120V, BOT, METAL 240V
26	GE-101254	1	DRIVE SHAFT ASSY (W/SPROCKETS)		2N-Z9917	10	HTR ELEMENT, 425W, 110V, TOP, METAL 220V
27	2P-200652	1	SPROCKET DRIVEN -17 tooth 3/8		2N-Z9918	10	HTR ELEMENT, 425W, 73V, 3PH Y, TOP, METAL
28	2P-200646	1	SPROCKET DRIVE - 20 tooth 5/16	54	2N-Z9912	6	HTR ELEMENT, 675W, 104V, BOT, METAL 208V
29	GB-Z10078	1	CHAIN, DRIVE - #25x16.25"		2N-Z9914	6	HTR ELEMENT, 675W, 120V, BOT, METAL 240V
30	2U-Z9657	1	CONVEYOR MOTOR RIGHT TO LEFT 50/60Hz		2N-Z9916	6	HTR ELEMENT, 700W, 110V, BOT, METAL 220V
	2U-Z9658	1	CONVEYOR MOTOR LEFT TO RIGHT 50/60Hz	55	GE-Z10074	5	RETAINER - 2 ELEMENTS
31	GE-100715	1	BELT SUPPORT	56	GE-Z9901	3	RETAINER - 2 ELEMENTS
32	GE-160031	1	CONVEYOR BELT W/ 3 LINKS - 82.5" LONG	57	2A-200672	3	SHAFT COLLAR - 3/8"
33	2B-200618	1	CONVEYOR BELT LINK, 14"				
34	2B-200620	3	CONVEYOR BELT SINGLE SPACE CLIP	NI	1P-Z8914	1	EXTREME PRESSURE MULTIPURPOSE SYNTHETIC GREASE (80°F TO 400°F) , TUBE 8 oz.
35	GE-402574	2	BEARING HOLDER				
36	2P-200766	2	SPRING, BEARING	NI	2E-200573	1	CONTRACTOR/RELAY - 3 PHASE OVENS
37	2P-200785	2	BEARING, SPRING LOADED	NI	2E-Z9782	2	TERMINAL BLOCK - ESE2 3 PH
38	GE-101255	1	IDLER SHAFT ASSY (W/SPROCKETS)	NI	PS-Z8977	1	STACKING KIT
39	2E-Z8966	2	CONTRACTOR/RELAY - 1 PHASE OVENS	NI	2E-Z10057	1	CORD SET, 50A, 2 POLE, 250V (Hubbell) CS8265C or equivalent
40	2E-200597	1	FUSEHOLDER - 2 POSITION, TYPE G				
41	2E-Z8405	2	FUSE - 15A TYPE G				
42	2E-200574	1	SWITCH, FAN (COOLDOWN)				
43	HG-402144	1	BRACKET, FAN SWITCH				
44	GE-Z9359	1	SPEED CONTROL POTENTIOMETER (500 OHM)				
45	2E-200180	1	INSULATION, SWITCH, POTENTIOMETER				
46	GE-Z10384	1	PANEL, FRONT CONTROL w/SWITCHES				
47	2M-Z10424	1	LABEL, DIAL w/POWER SAVER				
48		1	NUT, 3/8"-32 NEF, COMES WITH FIG. NO 52				
49	2R-200761	1	KNOB, SPEED CONTROL				
50	2E-Z9592	2	SWITCH, MAIN ON/OFF				
51	2J-Z10351	1	PILOT LIGHT - RED				
52	2A-101257	1	RETURN SHAFT ASSY (W/SPROCKETS)				