

2M-Z16577, Holman Conveyor Sandwich Conveyor QT14D

**Model:** QT14D Conveyor Toaster Cabinet Components



SK2629

Rev. -

11/21/2012

# PARTS LIST

October 13, 2014, Rev. D

QT14D Cabinet Components				
Fig No.	Part Number	Qty	Description	Application
1	2C-200007	4	SCREW 6-32X1 1/2 PHP SS	
2	GE-100991	1	TOP COVER, QT14	
3	GE-101593	1	UNLOAD TRAY ASSEMBLY	
4	2E-Z10526	1	SWITCH - SPDT	
5	2M-Z11571	1	LABEL, BELT DIRECTION	
6	GE-Z16506	1	PANEL PLATE, w/ROCKER SW	
7	GE-Z9903	2	CRUMB TRAY, ONE PIECE	
8	GE-Z16911	1	PANEL, CONTROL SIDE	
9	2M-Z10423	1	LABEL, QUIZNOS W/POWER SV	
10	2U-200577	2	MOTOR, FAN 240V, HI-OUTPU	
11	GE-Z16910	1	PANEL, FAN OFFSET LEFT	
12	2R-Z16753	2	FAN GUARD - MODIFIED	
13	2C-Z5883	8	10-24 X 1/2 FZA SCREW	
14	GE-Z16909	1	PANEL, FAN OFFSET RIGHT	
15	GE-Z9900	1	PANEL, BOTTOM COVER	
16	2A-Z0314	4	FOOT, 4" DIE CAST	
17	GE-Z16574	1	BRACKET, UNLOAD TRAY SHRT	
18	GE-Z10092	1	PANEL PLATE, W/RESET SW	
19	2E-200566	1	SWITCH, RESET, 0796	
20	GE-Z16809	1	PANEL, POWER INPUT	
21	GE-Z16806	1	ELECTRICAL BOX QT14	1 PHASE
	GE-Z16922			380/220V 3PH
22	2K-200464	1	BUSHING, WIRE RING 7/8"	
23	2E-Z9561	1	WIRE HARNESS, QT14 POWER	
24	GE-Z16811	1	ELECTRICAL BOX COVER	
25	GE-Z9911	1	PANEL, PLAIN CENTER	
26	GE-Z16810	1	PANEL, PLAIN SIDE	

2M-Z16577, Holman Conveyor Sandwich Conveyor QT14D



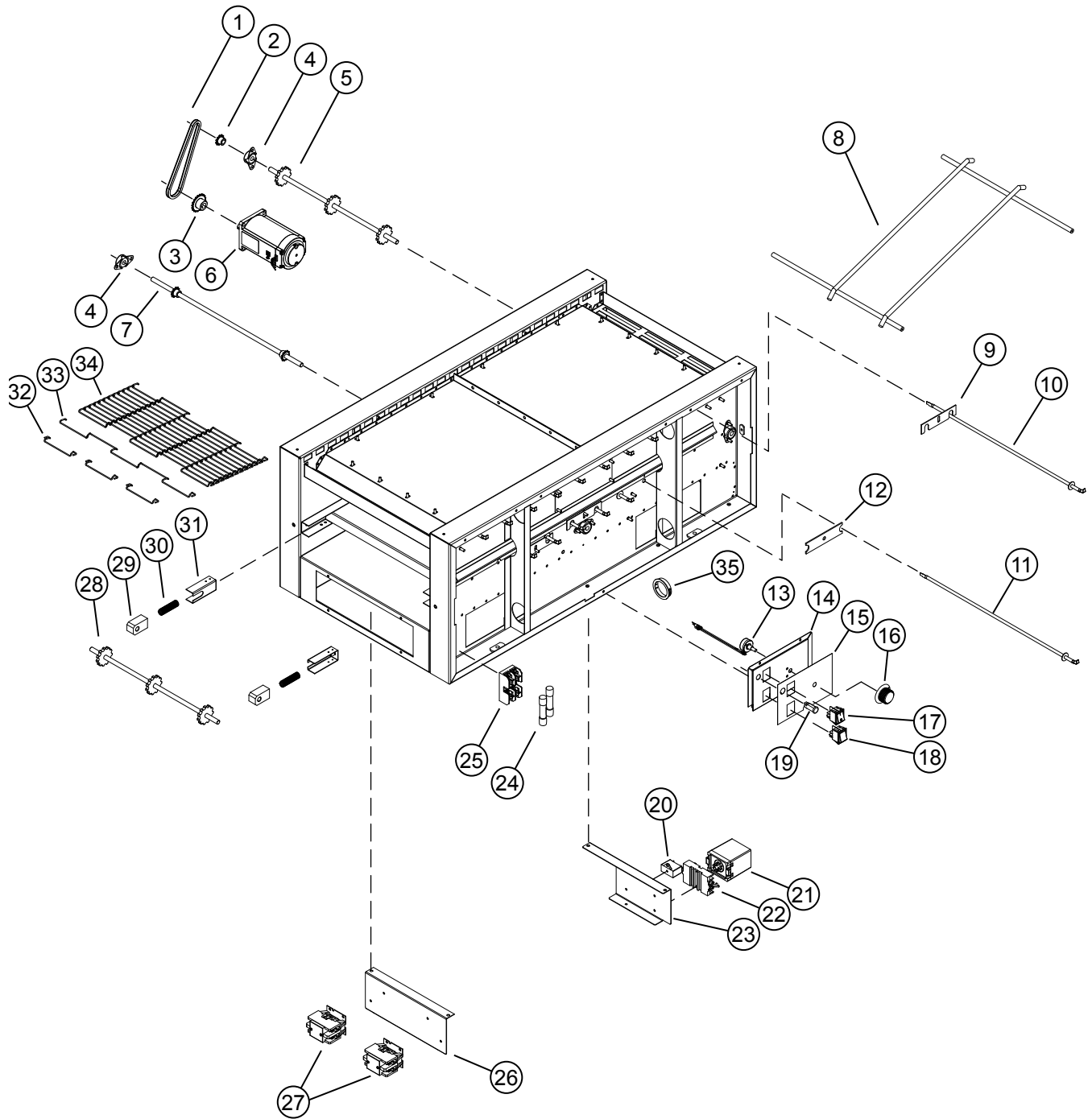

2M-Z16577, Holman Conveyor Sandwich Conveyor QT14D

**Model:** QT14D Conveyor Toaster  
Interior Components



SK2630

Rev. A

3/07/2013

# PARTS LIST

October 13, 2014, Rev. D

QT14D Interior Components				
Fig No.	Part Number	Qty	Description	Application
1	2P-150000	1	QT14 DRIVE CHAIN #25	
2	2P-115362	1	SPROCKET, 25B11 X 3/8	
3	2P-115366	1	SPROCKET 25B20 X 1/2	
4	GB-112262	4	BEARING ASSY, 3/8 PTFE	
5	GE-101254	1	QT14 DRIVE SHAFT ASSEMBLY	
6	2U-Z8629	1	GEAR MOTOR W/CAPACITOR	
7	2A-101257	1	RETURN SHAFT ASSY	
8	GE-100715	1	BELT SUPPORT RACK/QT14	
9	GE-Z10074	5	RETAINER, 2 ELEMENT	
10	2N-Z16525	10	HTR ELEMENT 425W 104V LIN	208V
	2N-Z16598		HTR ELEMENT 425W 120V LIN	240V/240CE
	2N-Z16600		HTR ELEMENT - 425W@110V	220CE
	2N-Z16601	9	HTR ELEMENT - 470W@73V	380V
	2N-Z16685		HTR ELEMENT - 470W@80V	415V
11	2N-Z16524	6	HTR ELEMENT 675W 104V LIN	208V
	2N-Z16597		HTR ELEMENT 675W 120V LIN	240V/240CE/415V
	2N-Z16599		HTR ELEMENT 675W@110V	220CE/380V
12	GE-Z10074	8	RETAINER, SMALL 2 ELEMENT	
13	2E-Z16575	1	POT ASSY, 20K HIGH-PASS	
14	GE-Z16582	1	PANEL, FRONT CONTROL W/SW	
15	2M-Z16581	1	LABEL, DIAL W/POWER SAVER	
16	2R-200761	1	KNOB,MM14-3, CONTROLLER S	
17	2E-72936	1	SWITCH ROCKER ON-OFF (Main Power)	
18	2E-Z16715	1	SWITCH, (Power Saver)	
19	2J-Z10351	1	PILOT LIGHT, HIGH TEMP	
20	2E-Z8629-1	1	RUN CAPACITOR	
21	2E-Z8628	1	SPEED CONTROL-GEAR MOTOR	
22	2E-Z8627	1	OCTAL SOCKET BASE	
23	GE-Z16399	1	BRACKET - SPEED CONTROL	
24	2E-Z8405	2	FUSE, 15A CLASS G	
25	2E-Z5681	1	FUSEHOLDER, CLASS G	
26	GE-Z9898	1	BRACKET, SINGLE CONTACTOR	
27	2E-Z8966	2	CONTACTOR 50 AMP 208/240V	
28	GE-101255	1	QT14 IDLER SHAFT ASSEMBLY	
29	2P-200785	2	PTFE BEARING	
30	2P-200766	2	1.750 x .625 SPRING	
31	GE-402574	2	BEARING HOLDER	
32	2B-200620	3	CONVEYOR BELT SINGLE SPACE CLIP	
33	2B-200618	1	CONVEYOR BELT LINK, 14"	
34	GE-160031	1	BELT, CNVY, 14X82.5", w/CLIP	
35	2K-Y8571	4	BUSHING, SNAP 2 1/8	1 PHASE
		6		3 PHASE

2M-Z16577, Holman Conveyor Sandwich Conveyor QT14D

