



**OPERATOR'S MANUAL
HOLMAN CONVEYOR TOASTERS
MODELS T710(H, TW, TX) T714(H, TW, TX) S710(H) S714(H) B710H
FOR SERVICE INFORMATION
U.S. AND CANADA CALL: 1-800-807-9054
24 HOURS/DAY 7 DAYS/WEEK**

TABLE OF CONTENTS

UNCRATING AND INSPECTION	PAGE 1
ASSEMBLY AND INSTALLATION	PAGE 1
POWER SAVER SWITCH	PAGE 2
SECURITY FEATURES	PAGE 2A
COOKING PROCEDURES	PAGE 3, 4
CLEANING PROCEDURES	PAGE 4
TROUBLESHOOTING GUIDE	PAGE 5, 6
MAINTENANCE PROCEDURES	PAGE 7, 8, 9
PARTS LIST/EXPLODED VIEW	PAGE 10, 11, 12, 13

DRAWINGS

CRUMB TRAY	PAGE 1
LOAD AND UNLOAD TRAYS	PAGE 1
ADJ. HEAT SHIELD, FRONT VIEW	PAGE 3
COMPONENT ARRANGEMENT	PAGE 6
HEATER TUBE INSTALLATION	PAGE 7
DRIVE SYSTEM	PAGE 9
WIRING DIAGRAMS [T710(H,TW)]	PAGE 15, 16
WIRING DIAGRAMS [T714(H,TW)]	PAGE 16, 17
WIRING DIAGRAMS [B710(H)]	PAGE 18
WIRING DIAGRAMS [S710(H), Jamba Juice]	PAGE 19
WIRING DIAGRAMS [S714(H)]	PAGE 20

REV. 9/10/2008

OPERATOR'S MANUAL
HOLMAN CONVEYOR TOASTERS
MODELS T710(H, TW, TX) T714(H, TW, TX) S710(H) S714(H) B710H

UNCRATING AND INSPECTION

Unpack unit and components from container. Remove all visible packing material, inspect unit for damage. If damage is discovered, file a claim immediately with the carrier that handled the shipment.

ASSEMBLY AND INSTALLATION

- A. Attach legs by screwing into weld nuts, as shown below.

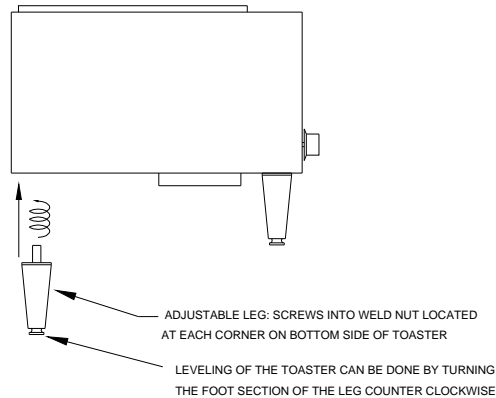

- B. Anti Skid pads are available at no charge and may be adhered to the foot section of each leg to prevent sliding. Call 1-800-225-3958 for details.

WARNING: the National Sanitation Foundation does not approve Use of these pads.

- C. Place load and unload trays as shown below.

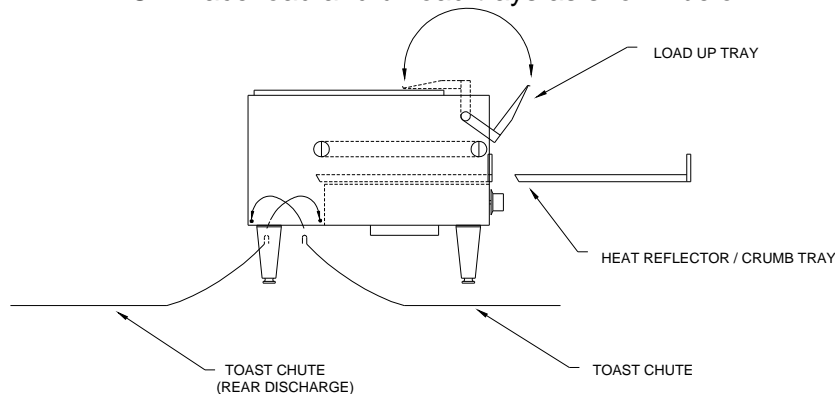

CAUTION: DO NOT OPERATE UNIT WITHOUT CRUMB TRAY PROPERLY POSITIONED AS THIS WILL CAUSE OVERHEATING IN THE CONTROL BOX.

WARNING: MAKE SURE ALL INPUT POWER IS **OFF** BEFORE INSTALLING/REMOVING ANY PARTS.

WARNING: BEFORE INSTALLING UNIT(S), CHECK WITH LOCAL POWER COMPANY TO DETERMINE ACTUAL VOLTAGE AT JOB SITE. NEVER PLUG A 208-VOLT UNIT INTO 240 VOLTS OR A 240 VOLT UNIT INTO 208 VOLTS.

WARNING: BE ABSOLUTELY SURE THE GROUND CONNECTION FOR THE RECEPTACLE IS PROPERLY WIRED. NEVER CONNECT UNIT TO POWER WITHOUT PROPER GROUND CONNECTIONS. IMPROPER GROUND MAY RESULT IN SEVERE INJURY OR FATALITY.

OPERATOR'S MANUAL
HOLMAN CONVEYOR TOASTERS
MODELS T710(H, TW, TX) T714(H, TW, TX) S710(H) S714(H) B710H

OPERATION

Your Holman toaster may be equipped with a Power Saver Switch, details are as follow;

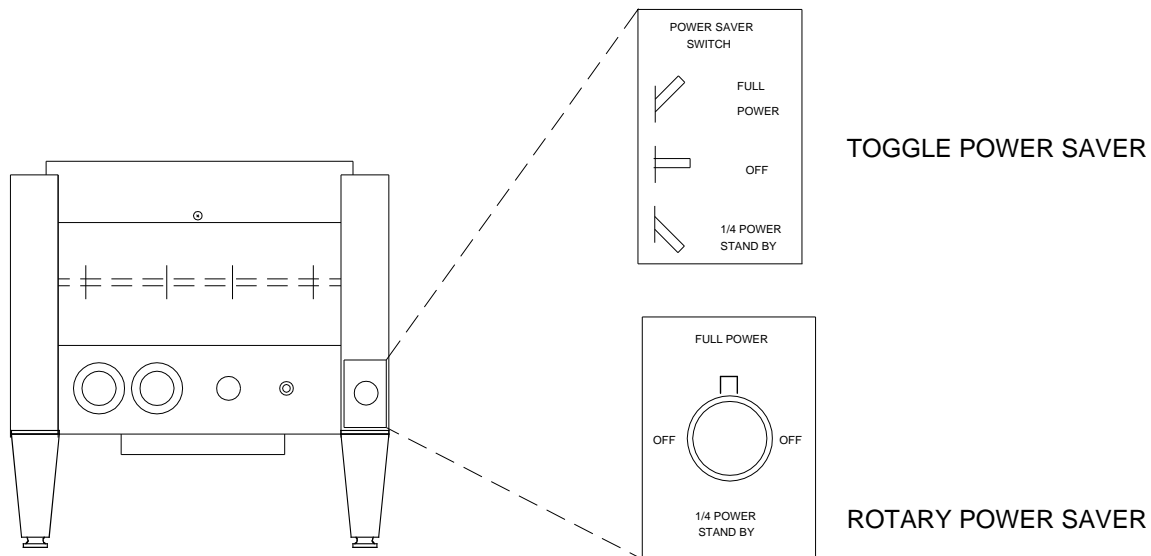

USING YOUR POWER SAVER SWITCH

**Power Saver
Switch Positions**

- FULL POWER-** When in this position your unit is at Full Power and ready to use. Adjust the Top and Bottom Variable Heat Controls and Conveyor Belt Speed Control to your desired settings.
- OFF-ROTARY:** Two off positions are provided so that a single rotation to either direction will result in the unit being turned OFF.
- OFF-TOGGLE:** The center position of the toggle switch turns the unit completely OFF regardless of heat and speed control settings.
- STANDBY-** The standby position reduces the power to the unit to 1/4, and therefore saves 75% of the energy consumption. In this position your unit will stay warm and reduce the reheat time when switched to Full Power to 20 to 30 seconds.

**OPERATOR'S MANUAL
HOLMAN CONVEYOR TOASTERS
MODELS S710(H), S714(H)**

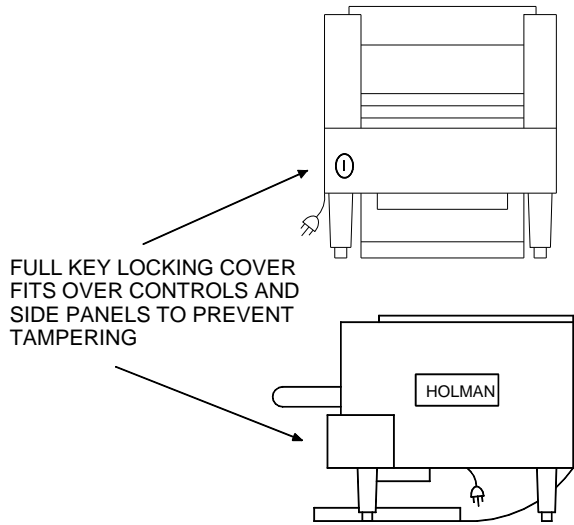

FULL KEY LOCKING COVER FITS OVER CONTROLS AND SIDE PANELS TO PREVENT TAMPERING

S710LOK.WMK

Fig. 1

SECURITY COVER :

Your Holman models S710 and S714 are quipped with a full front key locking cover (fig.1). This over fits over the front and sides of the unit. The security cover must be removed with a key in order to gain access to the controls, side panels, legs and toast chute to be removed.

To remove, unlock the cover using the key. Pull locked side of cover out and away from the unit. The right side will release at the same time.

To replace the cover, Hook the right side of the cover over the latch on right front of the unit while sliding the left side of the cover over the lock. Secure cover using key.

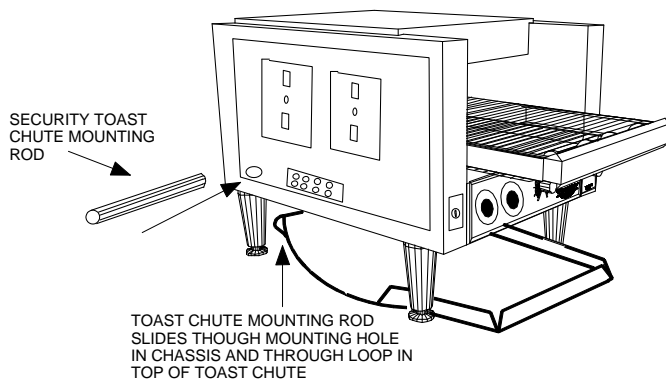

SECURITY TOAST CHUTE MOUNTING ROD

TOAST CHUTE MOUNTING ROD SLIDES THROUGH MOUNTING HOLE IN CHASSIS AND THROUGH LOOP IN TOP OF TOAST CHUTE

S710CHUT.WMF

Fig. 2

TOAST CHUTE ;

To install the toast chute (fig. 2), Remove the left side panel by removing two screws and pulling the top part of the panel out while lifting up. Remove the mounting rod by sliding it through chassis.

Next, place the toast chute beneath toaster as shown. Line up the looped end of toast chute with holes in the rear of toaster as shown. Insert mounting rod through the holes in chassis and the toast chute (If legs have not been installed, do so now).

Reinstall side panel and secure with screws. Toast chute is now ready for use.

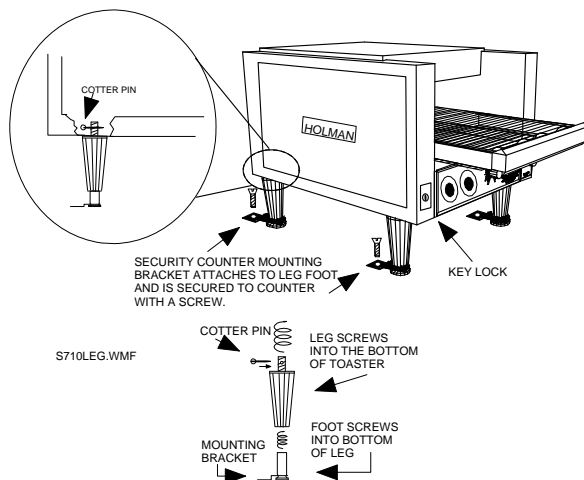

SECURITY COUNTER MOUNTING BRACKET ATTACHES TO LEG FOOT AND IS SECURED TO COUNTER WITH A SCREW.

KEY LOCK

S710LEG.WMF

CROTTER PIN
LEG SCREWS INTO THE BOTTOM OF TOASTER

FOOT SCREWS INTO BOTTOM OF LEG
MOUNTING BRACKET

Fig. 3

LEGS :

To secure the toaster to the counter (fig.3), Remove both side panels by removing two screws and pulling the top of the panel out while lifting up. Unscrew the foot of each leg and slide counter-mounting brackets onto the legs. Screw the foot back onto each leg and install legs onto the toaster. Place the small crotter pin through the holes in threaded portion of each leg.

Secure the mounting brackets to the counter with a screw or bolt. Reinstall both side panels and secure with screws.

NOTE: Security models are not supplied with a power saver switch.

HOLMAN CONVEYOR TOASTERS
MODELS T710(H, TW, TX) T714(H, TW, TX) S710(H) S714(H) B710H

COOKING PROCEDURES

A. BREAD TOASTING

NOTE: Models TX710(H) and TX714(H) have an extended conveyor belt in lieu of a load up tray. Place (do not press) the product on the extended conveyor belt for toasting or heating. Follow the instructions listed below for cooking and operation procedures.

1. On models T710H, TX710(H), T714H, TX714(H) and B710H, S710(H), S714(H) lower the front heat shield all the way down, leave just enough clearance for bread slices to pass under the shield into the cooking cavity (See illustration below).

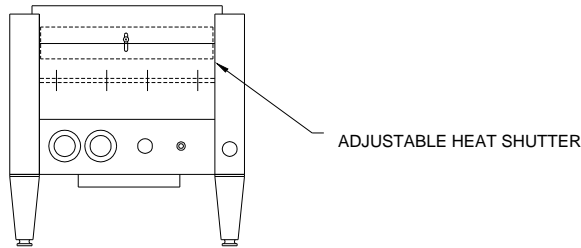

2. Turn top and bottom heat controls to HI; turn conveyor speed control to 50.
3. Allow warm up time of 5 to 10 minutes.
4. Test with a slice of bread.
 - a. If toast is too light, turn conveyor speed control counterclockwise to a slower speed.
 - b. If toast is too dark, turn conveyor speed control clockwise to a faster speed.

B. MODELS T710(H), TX710H, T714(H), TX714H, S710(H), S714(H)-BUN TOASTING

1. Buns may be top or bottom toasted. Turn appropriate heat control to HI, set conveyor speed control to 50.
2. On models with high (3") clearance (T710H, TX710H, T714H, TX714H, S710H, S714H), lower the front heat shield as far as possible, leave just enough clearance for the bun half to pass under and into the cooking cavity.
3. Test with a half of a bun.
 - a. If bun half is too light, turn conveyor speed control counterclockwise to a slower speed.
 - b. If bun half is too dark, turn conveyor speed control clockwise to a faster speed.

Cooking procedures continued on page 4

REVISED 9/10/2008

HOLMAN CONVEYOR TOASTERS
MODELS T710(H, TW, TX) T714(H, TW, TX) S710(H) S714(H) B710H

COOKING PROCEDURES CONT.

C. MODEL B710(H)

The model B710(H) has higher wattage tubes on the top than on the bottom, therefore when placing the bun halves on the conveyor you should place them cut side up.

D. DEEP TOASTING OR BAKING (Units with Variable Heat Controls).

Food products that require deep heating without exterior toasting may be heated by reducing the oven temperature (lowering the top and/or bottom heat controls) and cooking at slower speeds. Some foods may require more top heat than bottom heat or vice versa. Every product will require some experimentation to arrive at the correct balance of heat control and conveyor speed settings. Each time a setting is changed allow about 5 minutes for the unit to stabilize.

CLEANING PROCEDURES

1. Turn top and bottom heat controls to the OFF position.
2. For lightly soiled conveyor belts, turn conveyor speed control to fastest setting (100) and wipe with a damp cloth.
3. For heavily soiled conveyors, turn conveyor speed control to fastest setting (100) and wipe with a light abrasive pad.
4. Turn conveyor speed control off.
5. After the unit cools, remove interior crumb tray (as shown below) and clean. Slide crumb tray back into position. **DO NOT OPERATE UNIT WITHOUT CRUMB TRAY IN PLACE AS THIS CAUSES OVERHEATING IN THE CONTROL BOX AND MAY ACTIVATE THE HEAT LIMIT SWITCH.**
6. Wipe exterior surface of unit.

LUBRICATION OF DRIVE CHAIN WITH A GRAPHITE BASED LUBRICANT IS REQUIRED AS PERIODIC MAINTENANCE. CALL HOLMAN FACTORY SERVICE DEPARTMENT FOR DETAILS.

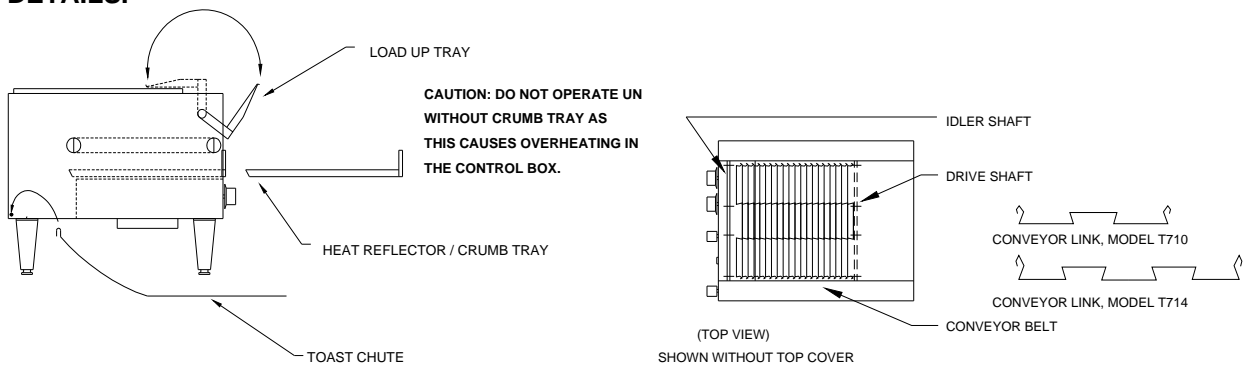

REVISED 9/10/2008

HOLMAN CONVEYOR TOASTERS
MODELS T710(H, TW, TX) T714(H, TW, TX) S710(H) S714(H) B710H

TROUBLESHOOTING GUIDE

A. UNIT WILL NOT HEAT, CONVEYOR WILL NOT TURN.

1. Be sure the main circuit breaker is switched to the ON position.
2. Check to see if the toaster is plugged in and all controls are turned to the ON position.

B. UNIT WILL NOT HEAT, CONVEYOR TURNS PROPERLY.

1. Check to see if both top and bottom heat controls have been turned to HI.
2. Push heat limit switch on front of control box as shown below.
If this reactivates the heater tubes, see HEAT LIMIT SWITCH in section C.

C. HEAT LIMIT SWITCH

Your Holman conveyor toaster is equipped with an automatically activated Heat Limit Switch that interrupts the heater tube connections if the ambient temperature in the control box exceeds 190F (88C). This heat limit switch can be reset manually by pushing the red button on the front of the control box.

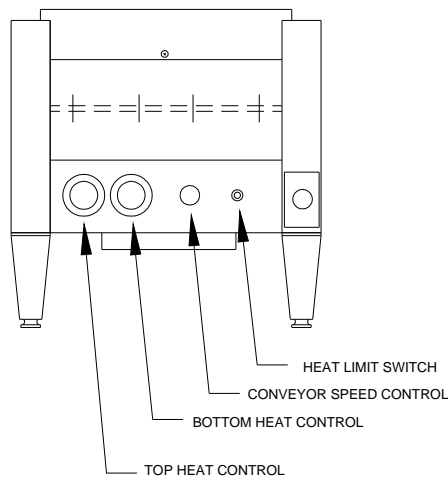

THE HEAT LIMIT SWITCH IS ACTIVATED WHEN THERE IS NOT SUFFICIENT AIR FLOW GENERATED BY THE COOLING FAN. WHEN HEAT LIMIT SWITCH HAS BEEN ACTIVATED:

1. DISCONNECT UNIT FROM POWER SOURCE.
2. Check to see if air intake area in the bottom center of the control box cover is free of dust, grease or other obstructions.

Troubleshooting guide continued on page 6

REVISED 9/10/2008

HOLMAN CONVEYOR TOASTERS
MODELS T710(H, TW, TX) T714(H, TW, TX) S710(H) S714(H) B710H

TROUBLESHOOTING GUIDE CONT.

3. Check if crumb tray is in place. NEVER OPERATE UNIT WITHOUT CRUMB TRAY IN PLACE AS THIS CAUSES OVERHEATING IN THE CONTROL BOX.
4. If no obstructions to the airflow can be found and if the crumb tray is in place, call Holman Factory Service Department at **1-800-225-3958** for assistance.

D. CONVEYOR WILL NOT TURN, UNIT HEATS PROPERLY.

1. DISCONNECT UNIT FROM POWER SOURCE.
2. Remove right hand side panel (from operator's position). Loosen screws holding drive motor in place and slide motor toward the rear of unit. Remove drive chain and manually move conveyor belt to check for mechanical binding. If conveyor moves freely, call Holman Factory Service Department at **1-800-225-3958** as drive motor and/or speed control may need replacement.

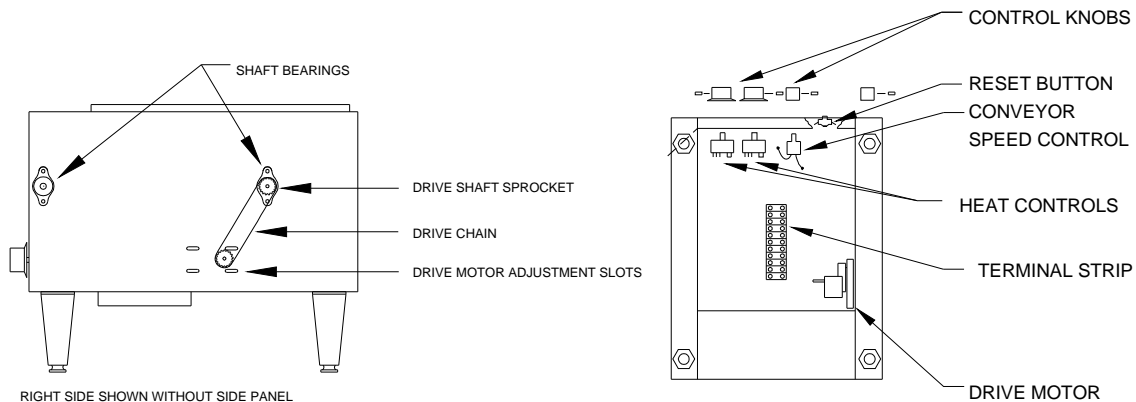

E. CONVEYOR TURNS AT ONE SPEED REGARDLESS OF SPEED CONTROL SETTING.

1. Call Holman Factory Service Department at **1-800-225-3958** as speed control should be replaced.

REVISED 9/10/2008

HOLMAN CONVEYOR TOASTERS
MODELS T710(H, TW, TX) T714(H, TW, TX) S710(H) S714(H) B710H

MAINTENANCE PROCEDURES

- A. REPLACING HEATER TUBES (as below)
1. DISCONNECT UNIT FROM POWER SOURCE.
 2. Remove right and left side panels.
 3. Remove heater tube wire from terminal block connection, keeping top and bottom wires separate.
 4. Remove heater tube retainers by removing retaining screws with washer.
 5. Gently, pull defective heater tube out of unit.
 6. Gently, put new heater tube into unit.
 7. Replace heater tube retainers, reconnect heater tube wires to terminal block and install side panels.

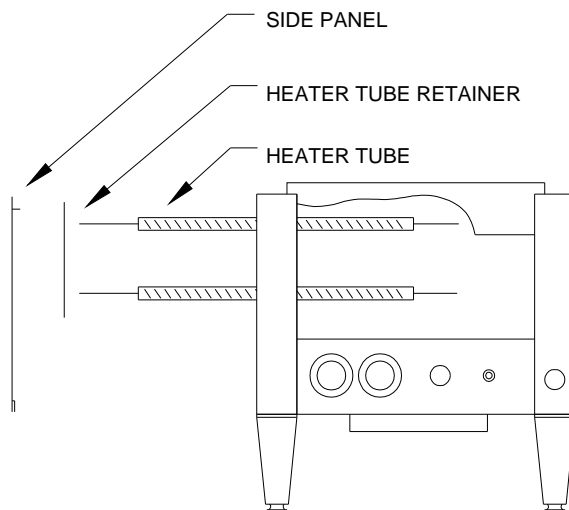
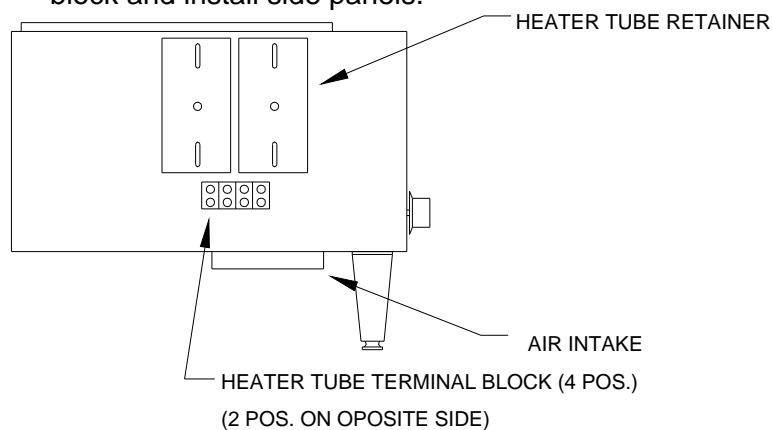

Maintenance procedures continued on page 8

REVISED 9/10/2008

HOLMAN CONVEYOR TOASTERS
MODELS T710(H, TW, TX) T714(H, TW, TX) S710(H) S714(H) B710H

MAINTENANCE PROCEDURES (CONT.)

B. REPLACING FAN MOTOR

1. DISCONNECT UNIT FROM POWER SOURCE.
2. Remove control box cover with fan motor.
3. Unplug power supply cord from fan motor.
4. Remove(4)screws that hold fan motor and grill to cover.
5. Put replacement motor and grill in place and secure to the control box cover with screws.
6. Reconnect power supply cord to fan motor.
7. Replace control box cover.

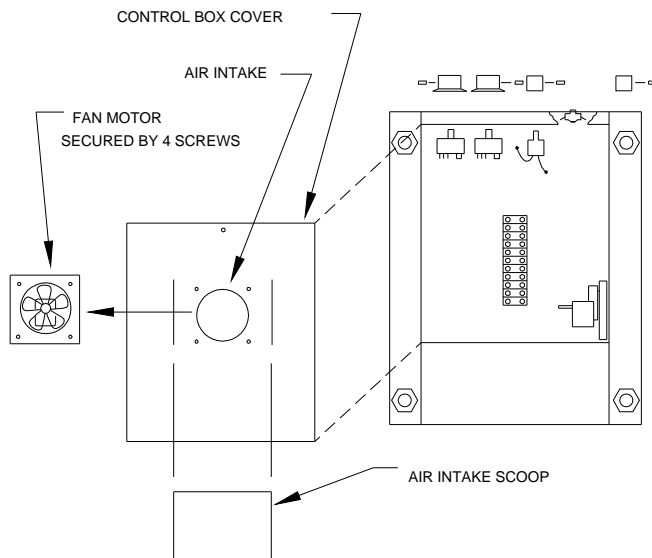

Maintenance procedures continued on page 9

REVISED 9/10/2008

**OPERATOR'S MANUAL
HOLMAN CONVEYOR TOASTERS
MODELS T710(H, TW, TX) T714(H, TW, TX) S710(H) S714(H) B710H**

MAINTENANCE PROCEDURES (CONT.)

C. REPLACING BELT DRIVE MOTOR

1. DISCONNECT UNIT FROM POWER SOURCE.
2. Remove right side panel and control box covers.
3. Remove sprocket from motor shaft.
4. Remove the wire from terminal block connecting the drive motor to internal wiring. On units rated 208 or 240 volts, note which color leads are being used for these connections and which lead is capped with white tape. The new motor should use the same arrangement.
5. Remove screws holding motor in place.
6. Put new motor in place and attach loosely with mounting screws.
7. Replace sprocket on motor shaft.
8. Slide motor until the drive chain has about 1/8" slack when lightly pushed at the center of its top open run.
9. Tighten screws to secure motor.
10. Rewire leads same as removed in step 4.
11. Replace side panel and control box cover.

IF ASSISTANCE IS REQUIRED FOR THIS OR ANY OTHER PROCEDURE IN THIS MANUAL CALL HOLMAN FACTORY SERVICE DEPARTMENT AT 1-800-807-9054, 24 HOURS/DAY 7 DAYS/WEEK.

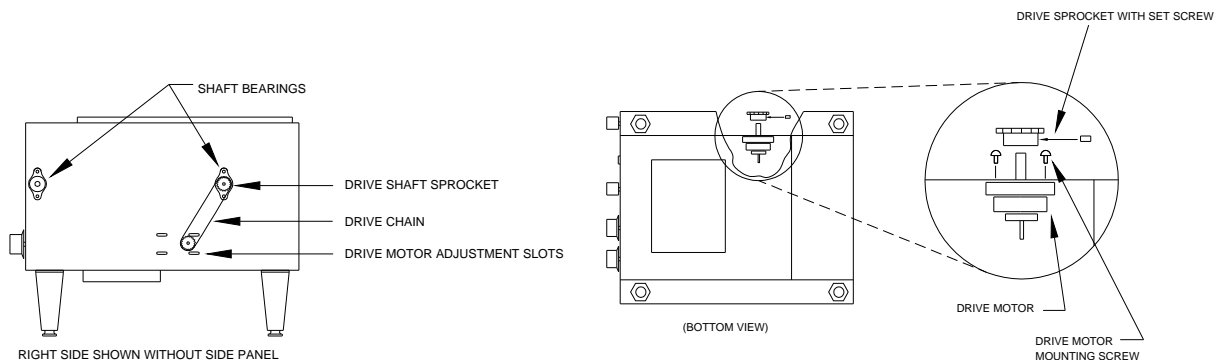

REVISED 9/10/2008