

2M-Z19588; Toastmaster Conveyor Toaster, TCT1, TCT2, TCT3

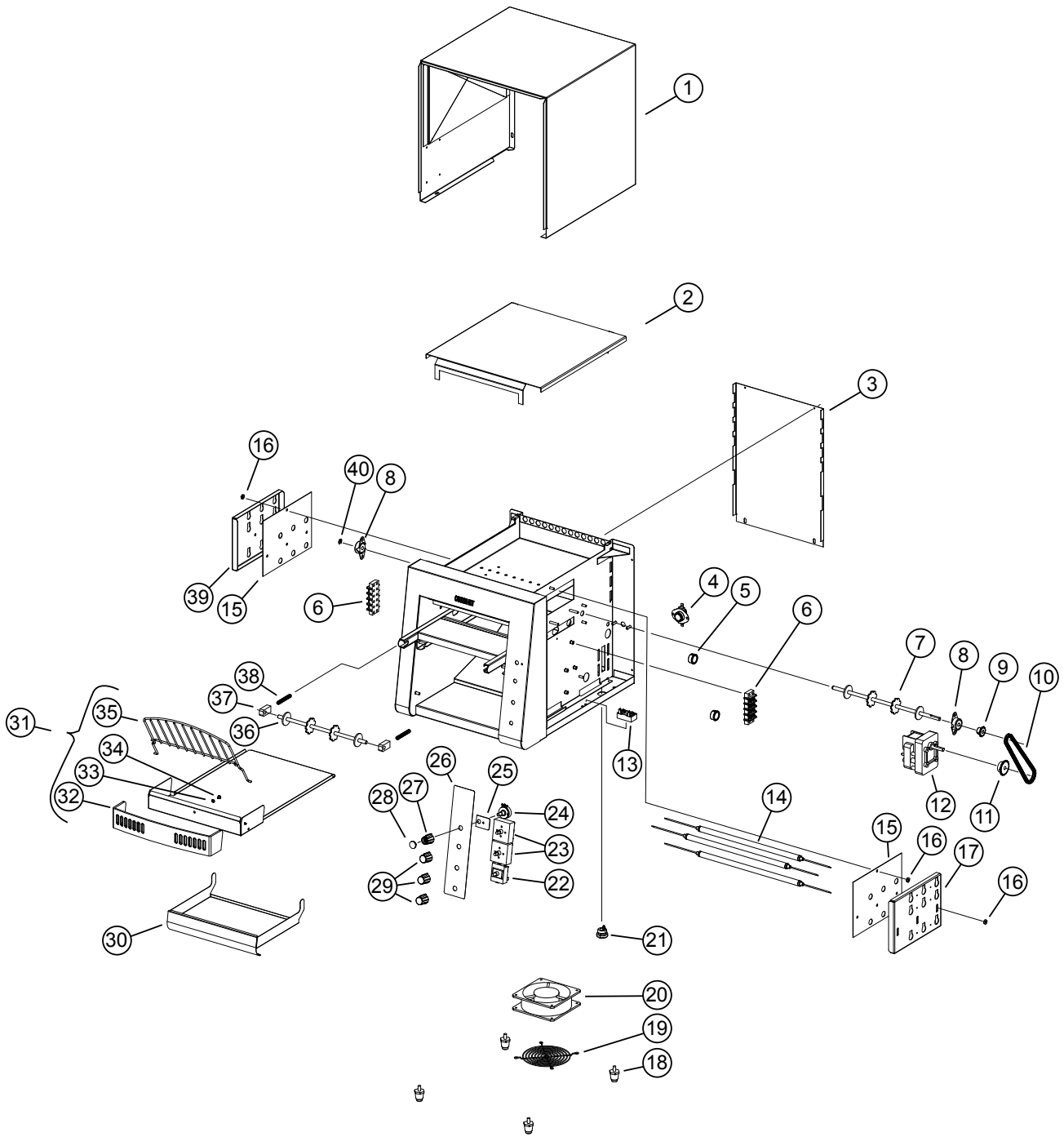

Model: TCT2, TCT3 Conveyor Toaster

SK2836 Rev. - 12/16/2014

PARTS LIST

December 16, 2014, Rev. -

MODEL: TCT2 & TCT3 Conveyor Toaster				
Fig. No	Part Number	Qty	Description	Application
1	HB-120364	1	ENCLOSURE ASSY TCT2,3	
2	HB-120270	1	TOP BAFFLE ASSY QCS-2 LO	
3	HC-Z10412	1	BACK PANEL QCS-2	
4	2E-200566	1	SWTCH,RSET,0796-190F TRPS	
5	2K-200464	2	BUSHING, WIRE RING 7/8"	
6	2E-Z10406	2	TERMINAL BLOCK 4 POS	
7	2A-202900	1	SHAFT, T710 DRIVE	
8	HA-112261	2	BEARING ASSY, 5/16 PTFE	
9	2P-Z8779	1	SPROCKET 25P-11T .313 ID	
10	2P-150013	1	DRIVE CHAIN #25 ROLLER	
11	2P-200645	1	SPROCKET, 25B17 X 5/16	
12	2U-Z13803	1	MOTOR, DRIVE 120V CW	TCT2-120V, 120C
	HB-120262		MOTOR ASSY 208-240V	TCT3-208V, 240v
13	2E-Z9736	1	TERMINAL BLOCK - POWER	
14	HD-198042	6	HEATERTUBE, QCS-2-500, 12	TCT2-120V, 120C
	HO-197841	4	HTRTBE,QTZ-208V,703W@104V	TCT3-208V
	HO-197842		HTRTBE,QTZ,707W@120V,210H	TCT3-240V
15	HB-Z10857	2	ELEMENT GUIDE PLATE	TCT2
	HB-Z10858			TCT3
16	2C-200230	9	NUT 10-24 HEX SS	
17	HC-Z10390	1	ELEMENT RETAINER,RHT,QCS-	
18	2R-200709	4	LEG,1" CHRМ PLSTC,1/4-20	
19	2R-200562	1	FAN GUARD FOR MUFFIN FAN	
20	2U-200559	1	MOTOR, FAN 120V 12A12-BTM	TCT2-120V, 120C
	2U-200560		MOTOR, FAN, 240V 23BTL	TCT3-208V, 240V
21	2K-Y2968	1	BUSHING - HEYCO 7W-2	
22	2E-200551	1	SWITCH ROTARY	
23	2J-200538	2	SWITCH, EGO 240V INFINITE	TCT3-208V,240V
	2J-200539		SWITCH, EGO INFINITE, 120	TCT2-120V, 120C
24	HA-120239	1	SPEED CONTROL ASSEMBLY	TCT2-120V, 120C
	HB-120261		SPD CNTL ASSY, 500 OHM POT	TCT3-208V
25	2P-402728	1	POT, ANTI SPIN PLATE	
26	2M-Z19205	1	LABEL CONTROL PNL TCT2&3	
27	2R-200768	1	KNOB, CONTROL/SPEED	
28	2R-200708	4	KNOB, CONTROL CAP	
29	2R-200769	3	KNOB, POWERSVR-INF.CTRL	
30	HA-100560	1	TRAY, PULL OUT, QCS, 10	
31	PS-120367	1	CRUMB TRAY ASSY	TCT2, TCT3
32	2R-Z19200	1	BURN GUARD - TOASTMASTER	
33	2C-200101	1	WASHER #6 SPLIT SS	
34	2C-Z9875	7	SCREW, 6-32 X 5/8 PH,TH,	
35	2B-200763	1	LOADUP, 10 EURO,WIRE	
36	2A-202904	1	SHAFT, 210HX IDLER	
37	2P-200700	2	BRG SPRING LOADED	
38	2P-200736	2	2 INCH BEARING SPRING	
39	HC-Z10389	1	ELEMENT RETAINER,LFT,QCS-	
40	2A-200284	1	E-CLIP 5/16"	
NI	2B-200601	1	BELT,CONVEYOR-10"WIDE	

2M-Z19588; Toastmaster Conveyor Toaster, TCT1, TCT2, TCT3

PARTS LIST

December 16, 2014, Rev. -

MODEL: TCT2 & TCT3 Conveyor Toaster				
Fig. No	Part Number	Qty	Description	Application
NI	2M-Z10833	1	LABEL,-W.D.SERIES	TCT3-208V, 240V
NI	2M-Z10834	1	LABEL,W.D.,PARALLEL	TCT2-120V, 120C
NI	HA-120241	1	CORD SET ASSEMBLY QCS-1	TCT2-120V
NI	HA-120242	1	CORDSET ASSY CUL20	TCT2-120C
NI	HA-120245	1	CORDSET ASSY NEMA 6-20P	TCT3-208V
NI	HC-402134	1	NC10H SHUTTER ROD	TCT3
NI	HC-402206	1	HEAT SHUTTER, SWINGING	TCT3
NI	SP-160027	1	BELT-CONVEYOR, 10X35-1/2	TCT2

2M-Z19588; Toastmaster Conveyor Toaster, TCT1, TCT2, TCT3