

This drawing contains information confidential to Star Manufacturing International, Inc.
 No reproduction or disclosure of its contents is permitted.
 SOME ITEMS ARE INCLUDED FOR ILLUSTRATIVE PURPOSES ONLY AND IN
 CERTAIN INSTANCES MAY NOT BE AVAILABLE

MODEL: UM3255 - Front Panel Assy

STAR MANUFACTURING INTERNATIONAL, INC.
 SK2198 Rev. B 12/5/06





UM3240, UM3255 Front Panel Assy

Fig No.	Part Number	Quantity Per	Description	Fig No.	Part Number	Quantity Per	Description		
1	2C-Z6925	16	SCREW #8 X 1/2 HEX SS SDR	30	2C-Z2206	32	BOLT 3/8-16X1 1/4 HEX STL, CASTER LOW PROFILE BASE		
2	B5-Z8647	1	TOP REAR PANEL	UM3240	2C-Z2206	48	BOLT 3/8-16X1 1/4 HEX STL, CASTER		
2	B5-Z9059	1	TOP REAR PANEL	UM3255	31	2A-Z9083	4	PLATE, TRIPLE STACK LEG LOW PROFILE BASE	
3	B5-Z8648	1	TOP FRONT PANEL	UM3240	32	B5-Z9084	4	FOOT PLATE TRIM LOW PROFILE BASE	
	B5-Z9060	1	TOP FRONT PANEL	UM3255	33	2C-Y9767	32	WASHER .390x.718x.048 LOW PROFILE BASE	
4	B5-Z8650	4	STACKING CORNERS		2C-Y9767	48	WASHER .390x.718x.048		
5	B5-Z9039-7	2	INSULATION-TOP LINER	UM3240	34	2C-Y9771	16	NUT, HEX 3/8-16 LOW PROFILE BASE	
	B5-Z9071-2	2	INSULATION-TOP LINER	UM3255	2C-Y9771	32	NUT, HEX 3/8-16		
6	B5-Z9037	2	RESTRICTOR PLATE		35	B5-LC0010	2	TOP RETURN BAFFLE ASSY	UM3240
7	2C-Z5182	4	THUMB SCREW 1/4-20x1/2		B5-LC0010	3	TOP RETURN BAFFLE ASSY	UM3255	
8	B5-Z9029	2	CRUMB TRAY		36	B5-Z9020	2	LOWER RETURN DUCT	UM3240
9	B5-Z8603	2	CONVEYOR GUIDE 40	UM3240	B5-Z9020	3	LOWER RETURN DUCT	UM3255	
	B5-Z9057	2	CONVEYOR GUIDE 55	UM3255	37	B5-LC0003		FINGER BODY ASSY SEE CHART	
10	2I-Z8656	2	DOOR HINGE UM3240		38	VARIES		COULUMNATING PLATE SEE CHART	
	2I-Z8656	4	DOOR HINGE UM3255		39	VARIES		NOZZLE PLATE SEE CHART	
11	B5-Z9459	4	HINGE SPACER PLATE	UM3240					
	B5-Z9459	8	HINGE SPACER PLATE	UM3255					
12	B5-LC0028	1	SMALL DOOR ASSY	UM3255					
13	2C-1513	3	SCREW 10-24X1/2 RHP STL NP, DOOR LATCH						
14	2C-6260	3	WASHER #10 INT STL NP, DOOR LATCH						
15	2C-Z3780	3	RETAINER, DOOR LATCH						
16	B5-Z9043-4	1	DOOR LATCH						
17	B5-LC0019	1	DOOR ASSY COMPLETE	UM3240					
	B5-LC0030	1	DOOR ASSY COMPLETE	UM3255					
18	B5-Z8677	1	ACCESS DOOR						
19	2Q-Z8678	1	GLASS, ACCESS DOOR						
20	B5-Z8681	1	GLASS RETAINER						
21	2C-Y1221	2	BOLT 1/4-20X1/2 HEX STL, DOOR HANDEL						
22	2R-Z8679	1	ACCESS DOOR HANDLE						
23	2C-Z5026	4	SCREW 8-32X1/2 SS SHCS						
24	B5-LC0031	1	BASE FRAME	UM3240					
	B5-LC0032	1	BASE FRAME	UM3255					
25	B5-Z9039-6	2	INSULATION-BASE TRAY	UM3240					
	B5-Z9071-3	2	INSULATION-BASE TRAY	UM3255					
26	B5-Z8602	4	BASE LEG BODY						
27	2A-Z8600	4	BOTTOM LEG PLATE						
28	2P-Z8617	4	CASTER, 5"H 2"W						
29	2A-Z8618	4	6" EQUIPMENT LEG						

	#37	#38	#39
UMNA-0	B5-LC0003	B5-Z10047	B5-Z9465
UMNA-1	B5-LC0003	B5-Z8614	B5-Z8613
UMNA-2	B5-LC0003	B5-Z8614	B5-Z9466
UMNA-3	B5-LC0003	B5-Z8614	B5-Z9467
UMNA-4	B5-LC0003	B5-Z8614	B5-Z9468

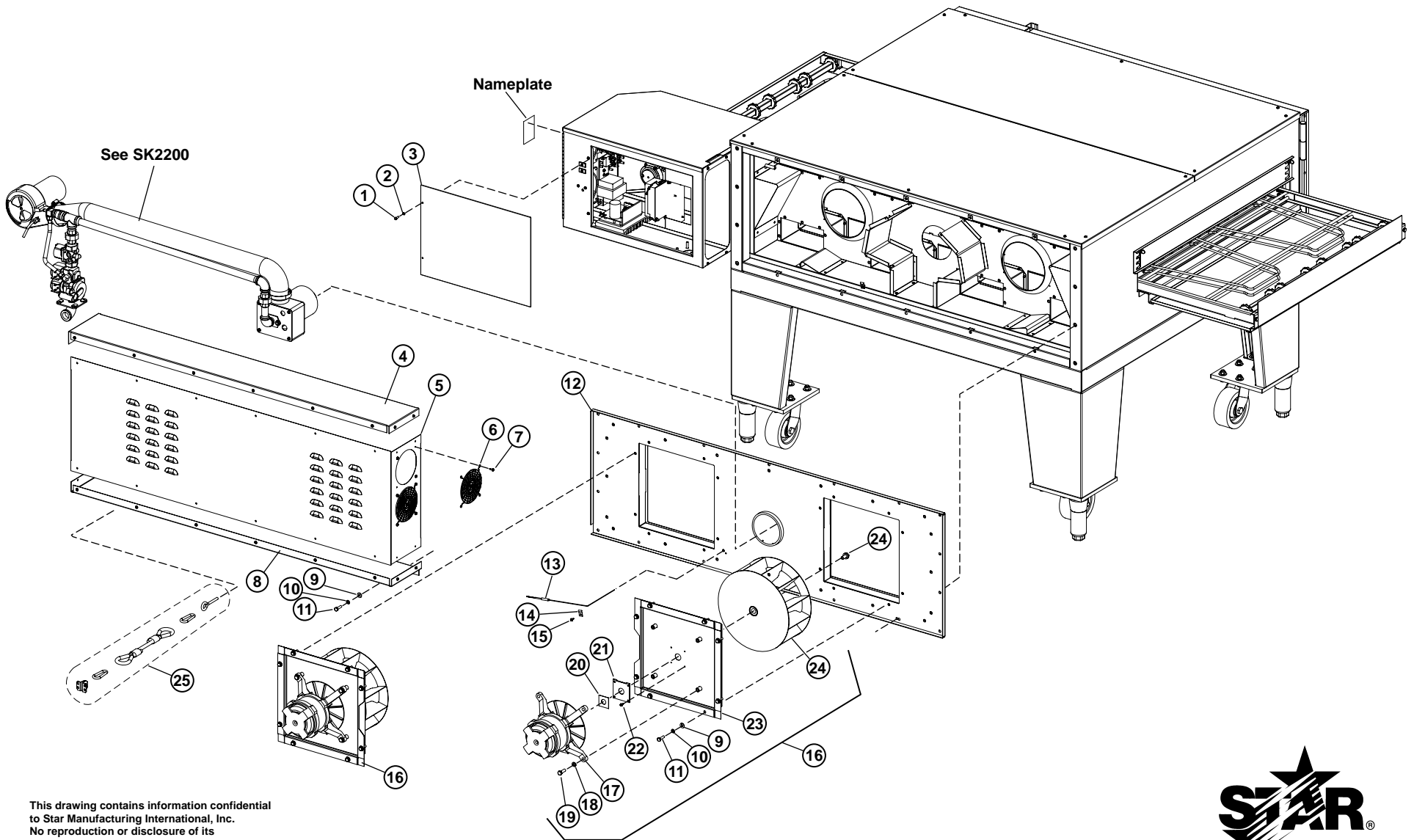

This drawing contains information confidential to Star Manufacturing International, Inc. No reproduction or disclosure of its contents is permitted.

SOME ITEMS ARE INCLUDED FOR ILLUSTRATIVE PURPOSES ONLY AND IN CERTAIN INSTANCES MAY NOT BE AVAILABLE

MODEL: UM3255 - Rear Panel Assy



STAR MANUFACTURING INTERNATIONAL, INC.

SK2199

REV. B

5/06/08



UM3240, UM3255 Rear Panel Assy

Fig No.	Part Number	Quantity Per	Description	Fig No.	Part Number	Quantity Per	Description
1	2C-1494	2	SCREW 8-32X1/2 RHP STL NP, REAR CONTROL PANEL	16	B5-LC0045	1	BLOWER ASSY COMPLETE, LEFT VIEWED FROM FRONT
2	2C-H8670	2	WASHER #8 INT STL NP, REAR PANEL		B5-LC0044	1	BLOWER ASSY COMPLETE, RIGHT VIEWED FROM FRONT
3	B5-Z9008	1	CONTROL BOX REAR COVER	17	2U-Z8670-1	2	BLOWER
4	B5-Z6891	1	REAR HOUSING TOP UM3240	18	2C-1824	9	WASHER-LOCK 5/16 SPLIT
	B5-Z9069	1	REAR HOUSING TOP UM3255	19	2C-Z8651	9	BOLT-HEX 5/16-18X1 SS
5	B5-Z8694	1	REAR HOUSING UM3240	20	2I-Z9032	2	AIR SEAL, BLOWER MOTOR
	B5-Z9065	1	REAR HOUSING UM3255	21	B5-Z9094	2	SHAFT SEAL RETAINER, BLOWER MOTOR
6	2R-200562	2	FAN GUARD	22	2C-Z6925	8	SCREW,#8 X.5 TEK HW SS, SHAFT SEAL
7	2C-Z6925	28	SCREW,#8 X.5 TEK HW SS, REAR PANEL	23	B5-LC0015	2	FAN PANEL ASSY
8	B5-Z8693	1	REAR HOUSING BOTTOM UM3240	24	2U-Z8670-2	2	BLOWER WHEEL & BOLT
	B5-Z9064	1	REAR HOUSING BOTTOM UM3255	25		1	RESTRAINING KIT
9	2C-Z5556	34	WASHER, FLAT 1/4 SS	NI	2E-Z9041	1	WIRING HARNESS, FREQUENCY INVERTER TO BLOWERS
10	2C-Z5557	34	WASHER, LOCK 1/4 SPLIT SS				
11	2C-Z5555	34	SCREW,1/4-20 X 3/4 HEX SS				
12	B5-LC0006	1	BLOWER FAN WALL ASSY UM3240				
	B5-LC0023	1	BLOWER FAN WALL ASSY UM3255				
13	2J-Z5189	1	THERMOCOUPLE ASSY				
14	2C-Z3350	1	HALF CLAMP - .188 DIA.				
15		1					

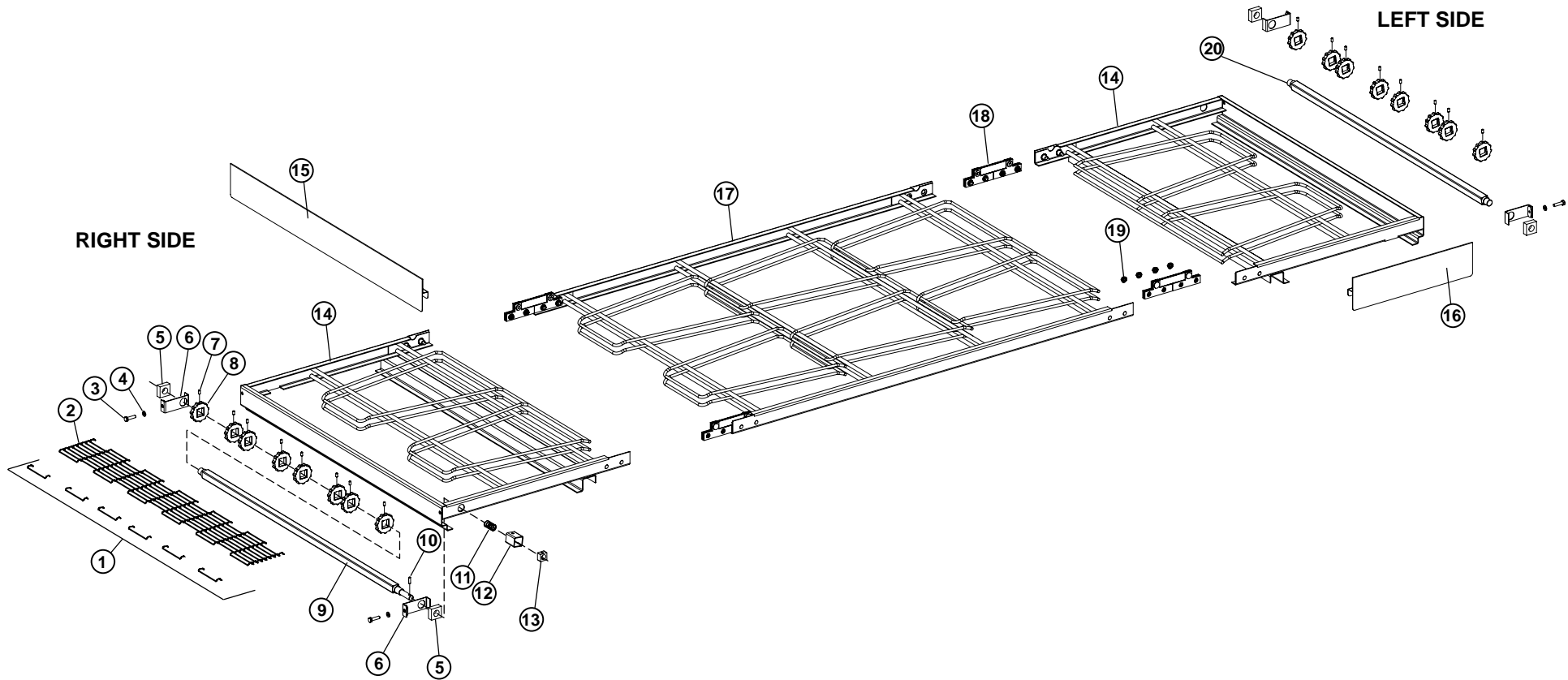

This drawing contains information confidential to Star Manufacturing International, Inc. No reproduction or disclosure of its contents is permitted.

SOME ITEMS ARE INCLUDED FOR ILLUSTRATIVE PURPOSES ONLY AND IN CERTAIN INSTANCES MAY NOT BE AVAILABLE

MODEL: Conveyor Assembly



STAR MANUFACTURING INTERNATIONAL, INC.

SK2201

REV. -

6/14/06



UM3240, UM3255 Conveyor Assembly

Fig No.	Part Number	Quantity Per	Description		Fig No.	Part Number	Quantity Per	Description	
1	PS-	1 KIT	BELT MASTER LINKS		11	2P-Z9051	1	SPRING-COUPLING	
2	B5-LC0042	1	CONVEYOR BELT	UM3240	12	B5-LC0013	1	COUPLING ASSY	
	B5-LC0043	1	CONVEYOR BELT	UM3255	13	2A-Z8601	1	AXLE COG	
2.1	2B-Z9046	1 FOOT	CONVEYOR BELT 32"W X 12"L		14	B5-LC0011	2	END CONVEYOR ASSY	
3	2C-Z5555	4	HEX BOLT 1/4"-20X.75 SS		15	B5-Z9086	1	END STOP	
4	2C-Z5557	4	LOCK WASHER 1/4 SPLIT SS		16	B5-Z9454	1	SIDE STOP	
5	2A-Z8665	4	BEARING BLOCK		17	B5-LC0012	1	CENTER CONVEYOR ASSY	UM3240
6	B5-Z8666	4	BEARING RETAINER			B5-LC0029	1	CENTER CONVEYOR ASSY	UM3255
7	2C-Z8663	16	SET SCREW 8-32X3/8 SS		18	B5-LC0017	4	HINGE ASSY	
8	2A-Z8621	16	SPROCKET-WIRE BELT		19	2C-Z9958	16	NUT 1/4-20 HEX SERRATED	
9	2V-LC0014	1	DRIVE SHAFT ASSY		20	2V-LC0004	1	IDLER SHAFT ASSY	
10	2A-Z9052	1	ROLL PIN						

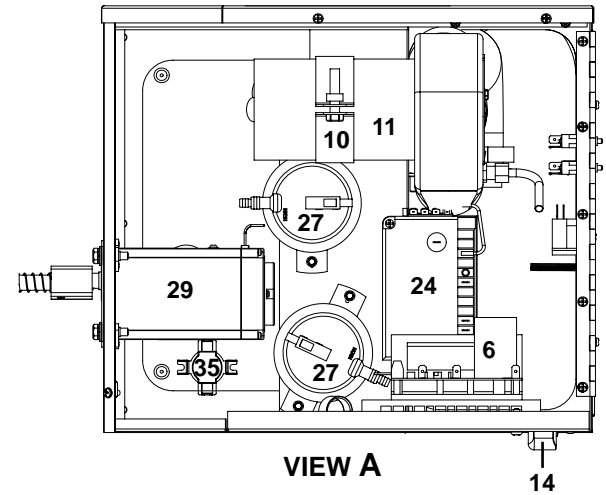
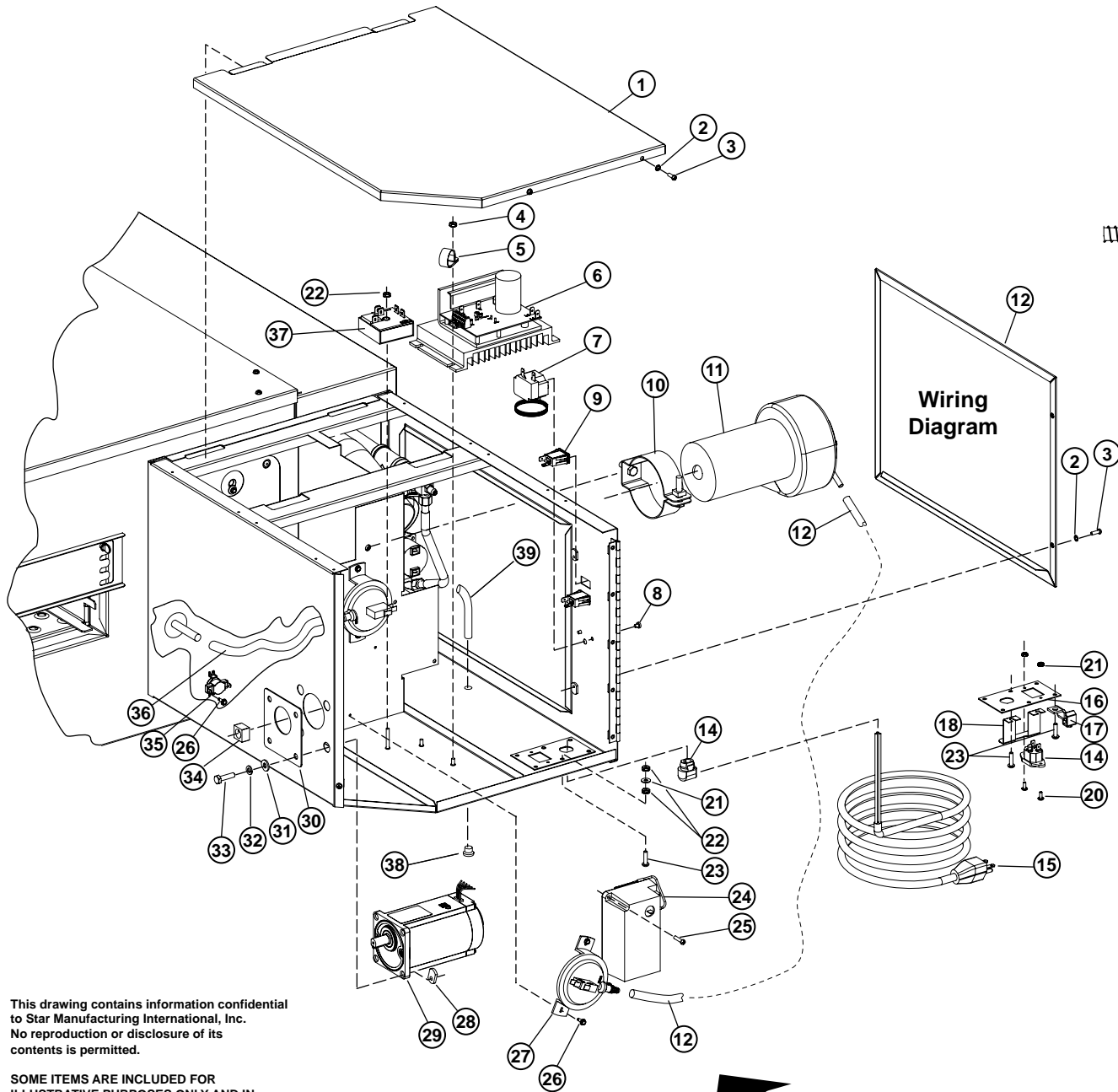

VIEW A
See SK2002

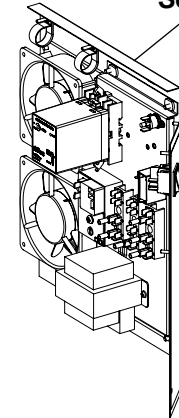

See SK2199:
FOR BLOWER MOTOR W/WIRING HARNESS

This drawing contains information confidential to Star Manufacturing International, Inc. No reproduction or disclosure of its contents is permitted.

SOME ITEMS ARE INCLUDED FOR ILLUSTRATIVE PURPOSES ONLY AND IN CERTAIN INSTANCES MAY NOT BE AVAILABLE

MODEL: UM3200 Series Control Box Assembly



SEE VIEW A



STAR MANUFACTURING INTERNATIONAL, INC.

SK2203

REV. C

6/25/07



UM3240, UM3255 Series Control Box Assembly

Fig No.	Part Number	Quantity Per	Description	Fig No.	Part Number	Quantity Per	Description
1	B5-Z9016	1	CONTROL BOX TOP LID	18	B5-Z10050	1	CORD HOLDER - IEC INLET
2	2C-H8670	4	WASHER #8 INT STL NP	19	2C-200201	2	6-32 HEX NUT,W/STAR WASHER
3	2C-1494	4	SCREW 8-32X1/2 RHP STL NP	20	2C-200004	2	SCREW, 6-32X38PHITRU SS410N
4	2C-Z3447	2	HEX NUT W/WASHER 8-32, FREQ. INVERTER	21	2C-1810	1	WASHER 3/16 BURR STL NP
5	2E-200468	3	CLAMP, NYLON WIRE 7/8	22	2C-08-07-0207	2	NUT 10-24 HEX STL NP W/LOCKWASH
6	2E-Z9007	1	FREQUENCY INVERTER	23	2C-1515	4	SCREW 10-24X.75 ST RH NP
7	2T-Z5177	1	THERMOSTAT HIGH LIMIT	24	2E-Z5163	1	IGNITION CONTROL, 24VAC
8	2C-Z0215	2	SCREW M4X5 ST NP PAN PH	25	2C-1496	2	SCREW 8-32 X 3/4 ST RH NP
9	2E-Z5206	2	BREAKER, CIRCUIT-10A	26	2C-Z6925	6	SCREW #8 X .5 TEK HW SS
10	2C-Z8652	1	CLAMP, BLOWER 3"	27	2E-Z5683	2	SWITCH-DIFFERENTIAL PRESSURE
11	2F-Z8616-1	1	COMBUSTION BLOWER	28	2C-H1027	4	NUT WELD 1/4-20, ANTI ROTATION, MOTOR
12	B5-Z9028-1	1	PRESSURE HOSE, SWITCH TO BLOWER	29	2U-Z8629	1	GEAR MOTOR W/CAPACITOR
13	B5-Z9008	1	CONTROL BOX REAR COVER	30	B5-Z8661	1	GEAR MOTOR COVER PLATE
14	2K-Y3240	1	BUSHING HEYCO SR 17-2	31	2C-Z5556	4	WASHER, FLAT 1/4 SS
	2E-Z3034	1	IEC CORD INLET HOT 10 AMP 230 VOLT	32	2C-Z5557	4	WASHER, LOCK 1/4 SPLIT SS
15	2E-Z9858	1	CORD SET, 14/3 6-15P 10'	33	2C-Z5555	4	SCREW,1/4-20 X 3/4 HEX SS
	2E-Z7278	1	CORDSET, UK 10A 90° BOTH ENDS 2.5METERS	34	2A-Z8633	1	DRIVE COG
	2E-Z0512	1	CORD SET, CONT. EUR 10A	35	2T-Z5175	1	THERMOSTAT, COOLDOWN TIMER
16	B5-Z8668	1	POWER INLET PLATE	36	B5-Z9028-2	1	SUCTION HOSE, SWITCH TO COOKING CHAMBER
17	2C-Y2344	1	TERMINAL GROUND	37	2E-Z7476	1	RELAY, TIME DELAY
				38	2K-Z2895	1	BUSHING
				39	1L-14-07-0100	1FT	TUBING-SILICONE 1/4 OD 1/16 WAL

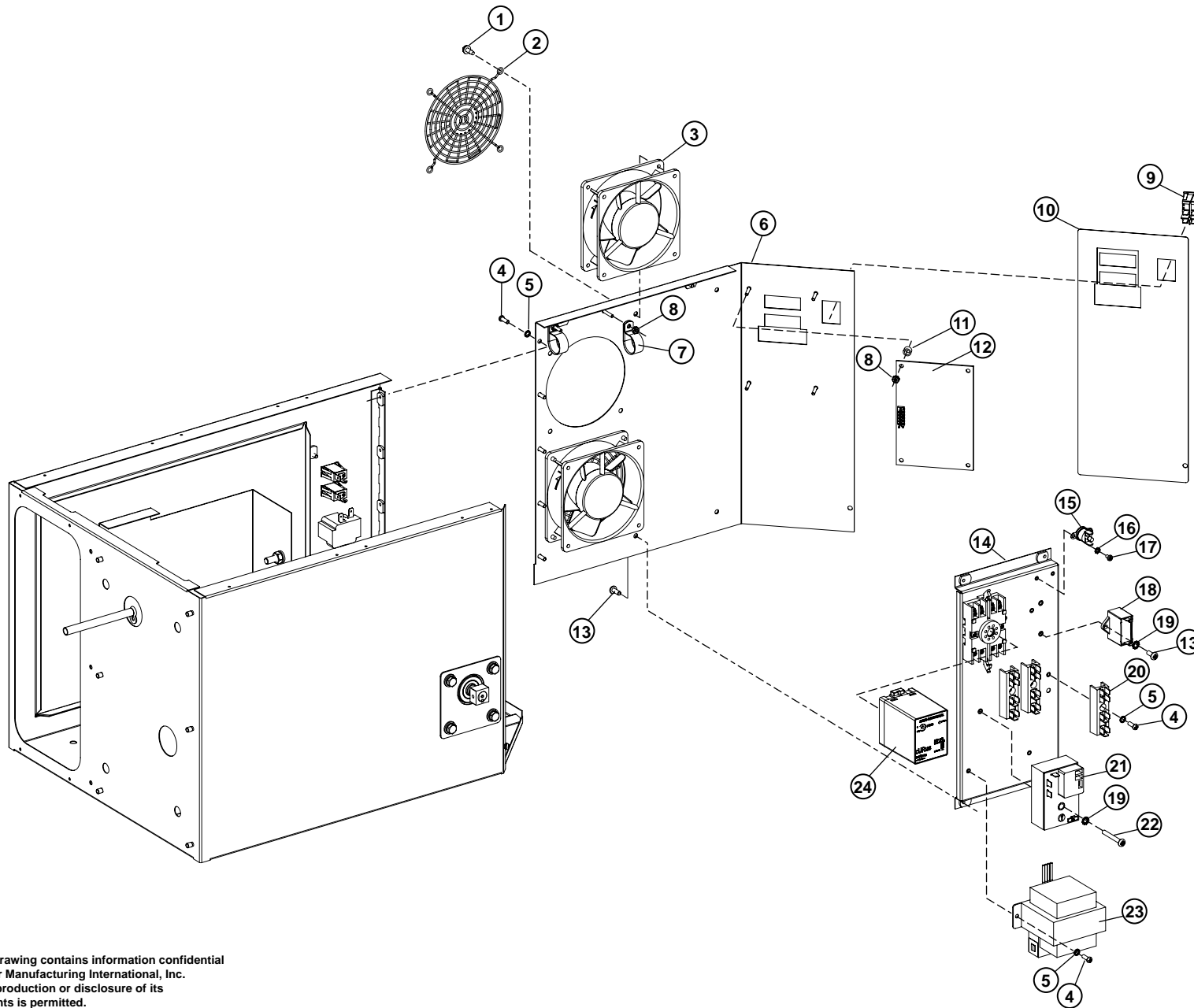

This drawing contains information confidential to Star Manufacturing International, Inc. No reproduction or disclosure of its contents is permitted.

SOME ITEMS ARE INCLUDED FOR ILLUSTRATIVE PURPOSES ONLY AND IN CERTAIN INSTANCES MAY NOT BE AVAILABLE

MODEL: UM3200 Series Control Box Door Assembly



STAR MANUFACTURING INTERNATIONAL, INC.

SK2202

REV. -

6/1/06



UM3240, UM3255 Series Control Box Door Assembly

Fig No.	Part Number	Quantity Per	Description	Fig No.	Part Number	Quantity Per	Description
1	2C-200048	8	SCREW, 10-24X1/2 HEX, SELF THREADING	15	2T-Z5176	1	THERMOSTAT, 140V
2	2R-200562	4	FAN GUARD FOR MUFFIN FAN	16	2C-4538	2	WASHER LOCK EXT 6 STL NP
3	2U-200577	2	MOTOR, FAN 240V, HI-OUTPUT, 23BTH	17	2C-1487	2	SCREW 6-32X1/4 RHP STL NP
4	2C-1494	16	SCREW 8-32X1/2 RHP STL NP	18	2E-Z8629	1	GEARMOTOR, BROTHER
5	2C-H8670	16	WASHER #8 INT STL NP	19	2C-1827	2	WASHER #10 EXT STL NP
6	B5-Z8662	1	CONTROL BOX DOOR	20	2E-Z4597	3	TERMINAL BLOCK 1/4 P.O.
7	2E-200468	3	CLAMP, NYLON WIRE 7/8	21	2E-Z9054	1	TIMER DELAY
8	2C-200201	6	HEX-NUT, W/STAR WASHER 6-32	22	2C-1557	1	SCREW 10-24X1 1/2 RHP STL NP
9	2E-Z1858	1	SWITCH-LIGHTED	23	2E-Z9090	1	TRANSFORMER, 120/208/240V/ CE
10	2M-Z9000	1	LABEL, CONTROL PANEL	24	2E-Z8628	1	SPEED CONTROL
11	2K-Z1971	4	SPACERS				
12	2J-Z7279	1	CONTROLLER, TIME/TEMP				
13	2C-1513	7	SCREW 10-24X1/2 RHP STL NP				
14	B5-Z8626	1	CONTROL MOUTN PANEL				

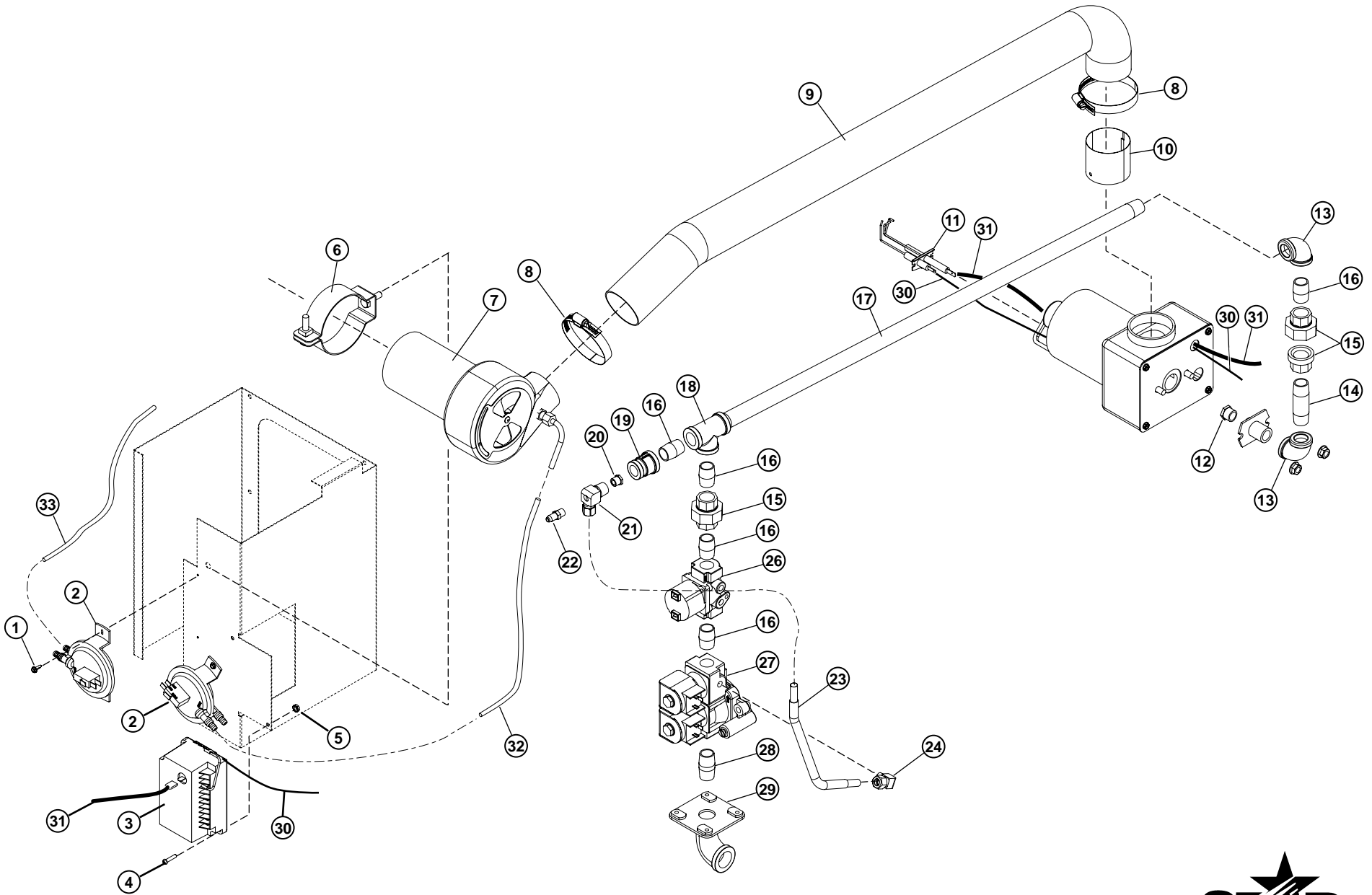

This drawing contains information confidential to Star Manufacturing International, Inc. No reproduction or disclosure of its contents is permitted.

SOME ITEMS ARE INCLUDED FOR ILLUSTRATIVE PURPOSES ONLY AND IN CERTAIN INSTANCES MAY NOT BE AVAILABLE

MODEL: UM3200 Manifold & Blower/Burner Assembly



STAR MANUFACTURING INTERNATIONAL, INC.

SK2200

REV. A

9/29/06



UM3240, UM3255 Manifold & Blower/Burner Assy

Fig No.	Part Number	Quantity Per	Description	Fig No.	Part Number	Quantity Per	Description
1	2C-Z6925	4	SCREW #8 X .5 TEK HW SS	18	2K-Z9004	1	TEE-1/2" NPT
2	2E-Z6583	2	SWITCH-DIFFERENTIAL PRESSURE	19	2K-3671	1	REDUCER 1/2"NPT TO 3/8"NPT
3	2E-Z5163	1	IGNITION CONTROL, 24VAC	20	2K-Z9025-1	1	ORIFICE LOW FIRE NAT #43
4	2C-1496	2	SCREW 8-32 X 3/4 ST RH NP	20	2K-Z9025-2	1	ORIFICE LOW FIRE LP #48
5	2C-Z3447	2	HEX-NUT W/WASHER 8-32	21	2K-Z9025	1	PILOT ELBOW
6	2C-Z8652	1	CLAMP, BLOWER 3"	22	2K-Z7221	1	NIPPLE, GAS TEST PRESSURE
7	2F-Z8616-1	1	BLOWER BURNER	23	2V-Z5194	1	TUBE, SS FLEX - 3/8X12
8	2C-Z9027	2	HOSE CLAMP	24	2A-Z5106	1	ELBOW, 1/8P-3/8T - BRASS
9	B5-Z9026-1	1	AIR HOSE	26	2V-Z5104	1	VALVE, SOLENOID 1/2 24V
	B5-Z9026-2	1	AIR HOSE	27	2V-Z6825	1	VALVE, GAS COMBI 1/2 24V
			UM3240	28	2K-Z3381	1	NIPPLE 1/2 NPT X 1&1/2
10	B5-Z9055	1	BURNER COUPLING	29	B5-LC0027	1	GAS INLET ASSY 3/4 NPT
11	B5-Z10005	1	IGNITOR/SENSOR, UM3200	30	2F-Z8616-3	1	WIRE IGNITION, BURNER TO IGNITION CONTROL
12	2F-Z8616-7	1	ORIFICE 40 LP .147D	31	2F-Z8616-4	1	WIRE SENSOR, BURNER TO IGNITION CONTROL
	2F-Z8616-5	1	ORIFICE 40 NAT .203D	32	B5-Z9028-1	1	PRESSURE HOSE, SWITCH TO BLOWER
	2F-Z8616-8	1	ORIFICE 55 LP .173D	33	B5-Z9028-2	1	SUCTION HOSE, SWITCH TO COOKING CHAMBER
	2F-Z8616-6	1	ORIFICE 55 NAT .234D				
13	2K-2667	2	ELBOW 90° 1/2 FPT IRON				
14	2K-9138	1	NIPPLE 1/2NPT X 2.5" STL				
15	2K-5877	2	UNION 1/2" NPT				
16	2K-1388	5	NIPPLE 1/2 NPT CLOSE STL				
17	2K-Z9001	1	NIPPLE 1/2 NPT X 22.437				
	2K-Z9056	1	NIPPLE 1/2 NPT X 29.938				
			UM3240				
			UM3255				