

# **STAR<sup>®</sup>** **LIGHTED** **WARMERS**

MODEL  
11 QUART

## **Installation and Operation Instructions**

2M-Y5817 Rev.I 12/14/10



11WLA



## SAFETY SYMBOL



These symbols are intended to alert the user to the presence of important operating and maintenance instructions in the manual accompanying the appliance.

---

## RETAIN THIS MANUAL FOR FUTURE REFERENCE NOTICE

Using any part other than genuine Star factory supplied parts relieves the manufacturer of all liability.

Star reserves the right to change specifications and product design without notice. Such revisions do not entitle the buyer to corresponding changes, improvements, additions or replacements for previously purchased equipment.

Due to periodic changes in designs, methods, procedures, policies and regulations, the specifications contained in this sheet are subject to change without notice. While Star International Holdings Inc., Company exercises good faith efforts to provide information that is accurate, we are not responsible for errors or omissions in information provided or conclusions reached as a result of using the specifications. By using the information provided, the user assumes all risks in connection with such use.

## MAINTENANCE AND REPAIRS

Contact your local authorized service agent for service or required maintenance.

Please record the model number, serial number, voltage and purchase date in the area below and have it ready when you call to ensure a faster service.

Model No. \_\_\_\_\_

Serial No. \_\_\_\_\_

Voltage \_\_\_\_\_

Purchase Date \_\_\_\_\_

### Authorized Service Agent Listing

Reference the listing provided with the unit

OR

for an updated listing go to:

**Website:** [www.star-mfg.com](http://www.star-mfg.com)  
**E-mail** [Service@star-mfg.com](mailto:Service@star-mfg.com)

### Service Help Desk

**Business Hours:** 8:00 am to 4:30 p.m. Central Standard Time

**Telephone:** (800) 264-7827 Local (314) 684-6303

**Fax:** (800) 396-2677 Local (314) 781-2714

**E-mail** [Parts@star-mfg.com](mailto:Parts@star-mfg.com)  
[Service@star-mfg.com](mailto:Service@star-mfg.com)  
[Warranty@star-mfg.com](mailto:Warranty@star-mfg.com)

**Website:** [www.star-mfg.com](http://www.star-mfg.com)

**Mailing Address:** Star International Holdings Inc., Company  
10 Sunnen Drive  
St. Louis, MO 63143  
U.S.A

LIGHTED WARMER SPECIFICATIONS									
Model	Capacity	Electrical			Dimensions			Weight	Approval Agency
		Volts	Hz	Amps	Depth	Width	Height		
11WLA	11 qt	120V	60	13.58	15.125"	13.25"	11.5"	17lbs	UL / CUL
		240V		6.8					
11WLA-C/UL		120V		13.6					
11WLA-HS		120V		13.79			18.75"	23lbs +	
		240V		6.9					
11WLA-HSC/UL		120V		13.6					
11WLA-P		120V		13.58			22lbs		
		240V		6.8					
11WLA-P-C/UL		120V		13.6					

**FOOD WARMERS WITH HEATED SPOUTS ARE ACCEPTABLE FOR POTENTIALLY HAZARDOUS FOODS.**

\* N - Nacho Sign, F - Fudge Sign, CD - Chili Dog Sign, BQ - BBQ Sign, C - Chili Sign, S - Soup Sign

**FOOD WARMERS WITHOUT HEATED SPOUTS ARE NOT ACCEPTABLE FOR POTENTIALLY HAZARDOUS FOODS.**

## GENERAL INFORMATION

This equipment is designed and sold for commercial use only by personnel trained and experienced in its operation and is not sold for consumer use in and around the home nor for use directly by the general public in food service locations.



## GENERAL INSTALLATION INSTRUCTIONS

These food warmers are equipped for the voltage and wattage indicated on the nameplate mounted to the bottom panel and are designed for use on alternating current (AC) only.



## DO NOT CONNECT TO DIRECT CURRENT (DC).

### PUMP INSTALLATION

Follow these simple instructions to install the pump into the heated spout casting.

1. Remove pump from warmer.
2. Swing retainer fastened to the pump heater casting down.
3. Press down on pump plate and turn pump counterclockwise until notches line up with bumps on black bowl.
4. Lift pump from bowl.
5. Open tin and remove paper label.
6. Place bowl lifter spring in black water bowl with one quart of hot water.
7. Turn on warmer switch "on".
8. Pre-Heat cheese before inserting pump. Pump will not function if cheese is too thick.
9. Be sure bowl lifter spring is placed inside water bowl before inserting container.
10. Place tin or bowl into unit. Bowl lifter spring should be centered under container.
11. Place pump in tin or bowl and line up notches in pump plate with bumps on black bowl.
12. Press down on pump plate until notches are below bumps on black bowl. Turn pump clockwise until pump spout engages groove in spout casting.
13. Swing lever up to prevent pump spout from disengaging.

## **GENERAL OPERATING INSTRUCTIONS**

### **11W MODELS**

These warmers are designed to use stainless steel serving bowls purchased as an option. Follow these simple steps for setting up the warmer:

1. Before using warmer clean the water food bowl and any accessories furnished with warmer.
2. Fill the warmer bowl with 24 to 36 ounces of water. Add water as required to maintain water level.
3. Place precooked food into a standard 11quart inset and insert into water bowl.
4. Turn warmer on. The temperature control on these warmers is a combination ON/OFF switch and thermostatic heat control. The OFF position will turn off the electric current to the heating element.
5. If preheating is desired set the control to the "HI" position for approximately 10 minutes. Prolonged "HI" setting may result in overcooking or scorching of certain foods.
6. On pump models with a heated spout, pre-heat fudge or cheese before inserting pump. Pump will not function if fudge or cheese is too thick.
7. Set the dial setting to the number required to maintain the desired temperature.
8. Because the consistency of different foods varies, and because liquids and solids absorb heat at different rates, it is impractical to specify an exact dial setting. However, at the point between figures "3" and "4" the temperature is approximately 145° F, the proper holding temperature for fudge. When the dial is set at the figure "5" the temperature is approximately 170° F, a good holding temperature for cheese sauce. After pre-heating, set the thermostat to the desired temperature.
9. Turn the control knob to the "OFF" position when the unit is not in use.
10. Do not keep unit on high heat for more than 45 minutes, as the food product may become overheated.



**DO NOT OPERATE THE UNIT ON HIGH HEAT FOR MORE THAN 45 MINUTES. FOODS MAY BECOME OVERHEATED.**

**DO NOT TOUCH THE HEATED SPOUT WITHOUT HEAT INSULATING MITTENS OR OTHER MEANS OF BURN PREVENTION.**

**DO NOT OPERATE UNIT WITHOUT WATER. CHECK WATER LEVEL FREQUENTLY.**

#### **PUMP SPOUT HEATER**

The pump spout heater casting keeps cheese left in the pump spout at or above 140°F when warmer is allowed to heat for 40 minutes prior to vending through pump. This prevents dispensing cold, dried cheese.

#### **HELPFUL HINTS FOR BETTER SERVICE**

The food product you serve in this warmer, as packed by the manufacturer, represents a high standard of quality and this quality should be protected by following the recommendations of the packer in serving of the product.

## CLEANING INSTRUCTIONS

### **IMPORTANT: Stainless steel may corrode if not cleaned properly.**

Clean and dry the heated bowl inside the warmer every night. Use a soft cloth and mild soap to keep exterior surfaces bright and shining. To keep the inside surface of the bowl clean, use S.O.S. or Brillo pads as often as necessary. Do not use detergents, strong abrasives or metal scouring pads on exterior surface of warmer.



**CAUTION**

### **DO NOT IMMERSE IN WATER AT ANY TIME.**

#### **PUMP CLEANING**

Before using and at least daily, disassemble the pump and wash all parts.

To disassemble pump:

1. Unscrew nut-cylinder. Pull pump-plunger from pump chamber.
2. Unscrew knob from plunger assembly and disassemble.
3. Unscrew cap-tube and nut-sleeve-tube from dispense tube. Remove cover from pump assembly.
4. Remove pin "U" from pump assembly and disengage dispense tube from pump chamber.
5. Remove balls from pump chamber.
6. Wash all parts thoroughly in hot soapy water and rinse thoroughly. Use 18" long brush to clean inside of dispensing tube. Reassemble pump. When reassembling pump, wet o-ring with edible vegetable oil, then reassemble. Make sure all parts are in their proper place.

#### **SANITIZING PUMP ASSEMBLIES**

It is recommended that the pump assembly be sanitized after routine disassembly and cleaning. Prepare a 200 ppm quaternary solution (similar to Pro-Quat 103). Immerse all pump parts in this solution for at least 60 seconds, remove and let air dry. Reassemble the pump.

#### **PRIMING PUMP**

Three (3) strokes of the pump plunger are necessary to initially prime and vend thick food products.



**CAUTION**

### **FAILURE TO DO THIS CAN CAUSE A BROKEN "O" RING TO BE PUMPED OUT WITH THE FOOD BEING VENDED.**

#### **SIGN REPLACEMENT 7WL AND 11WL MODELS**

1. Unplug cord from the receptacle.
2. Remove two screws in the sign retainer fastened to the bottom.
3. Pull forward on the bottom edge of the plastic panel and remove it.
4. Replace the sign.
5. Place the front plastic panel back into its original position.

#### **LIGHT BULB REPLACEMENT 11WLA MODELS**

1. Unplug cord from the receptacle.
2. Remove both front panels as stated above.
3. Replace bulbs with a 15 watt appliance type, medium base for 120V or a 10 watt medium base for 240V.

#### **MAINTENANCE AND REPAIRS**

Contact the factory, a service representative or a local service company for service or required maintenance.

### THOROUGHLY INSPECT YOUR UNIT ON ARRIVAL

This unit has been tested for proper operation before leaving our plant to insure delivery of your unit in perfect condition. However, there are instances in which the unit may be damaged in transit. In the event you discover any type of damage to your product upon receipt, you must immediately contact the transportation company who delivered the item to you and initiate your claim with same. If this procedure is not followed, it may affect the warranty status of the unit.

### LIMITED EQUIPMENT WARRANTY

All workmanship and material in Star products have a one (1) year limited warranty on parts & labor in the United States and Canada. Such warranty is limited to the original purchaser only and shall be effective from the date the equipment is placed in service. Star's obligation under this warranty is limited to the repair of defects without charge, by the factory authorized service agency or one of its sub-agencies. Models that are considered portable (*see below*) should be taken to the closest Star service agency, transportation prepaid.

- > Star will not assume any responsibility for loss of revenue.
- > On all shipments outside the United States and Canada, see International Warranty.
- \* The warranty period for the JetStar six (6) ounce & Super JetStar eight (8) ounce series popcorn machines is two (2) years.
- \* The warranty period for the Chrome-Max Griddles is five (5) years on the griddle surface. See detailed warranty provided with unit.
- \* The warranty period for Teflon/Dura-Tec coatings is one year under normal use and reasonable care. This warranty does not apply if damage occurs to Teflon/Dura-Tec coatings from improper cleaning, maintenance, use of metallic utensils, or abrasive cleaners, abrasive pads, product identifiers and point-of-sale attachments, or any other non-food object that comes in continuous contact with the roller coating. This warranty does not apply to the "non-stick" properties of such materials.
- > This warranty does not apply to "Special Products" but to regular catalog items only. Star's warranty on "Special Products" is six (6) months on parts and ninety (90) days on labor.
- > This warranty does not apply to any item that is disassembled or tampered with for any purpose other than repair by a Star Authorized Service Center or the Service Center's sub-agency.
- > This warranty does not apply if damage occurs from improper installation, misuse, wrong voltage, wrong gas or operated contrary to the Installation and Operating instructions.
- > This warranty is not valid on Conveyor Ovens *unless* a "start-up/check-out" has been performed by a Factory Authorized Technician.

### PARTS WARRANTY

Parts that are sold to repair out of warranty equipment are warranted for ninety (90) days. The part only is warranted. Labor to replace the part is chargeable to the customer.

### SERVICES NOT COVERED BY WARRANTY

1. Travel time and mileage rendered beyond the 50 mile radius limit
2. Mileage and travel time on portable equipment (*see below*)
3. Labor to replace such items that can be replaced easily during a daily cleaning routine, ie; removable kettles on fryers, knobs, grease drawers on griddles, etc.
4. Installation of equipment
5. Damages due to improper installation
6. Damages from abuse or misuse
7. Operated contrary to the Operating and Installation Instructions
8. Cleaning of equipment
9. Seasoning of griddle plates
10. Voltage conversions
11. Gas conversions
12. Pilot light adjustment
13. Miscellaneous adjustments
14. Thermostat calibration and by-pass adjustment
15. Resetting of circuit breakers or safety controls or reset buttons
16. Replacement of bulbs
17. Replacement of fuses
18. Repair of damage created during transit, delivery, & installation OR created by acts of God

### PORTABLE EQUIPMENT

Star will not honor service bills that include travel time and mileage charges for servicing any products considered "Portable" including items listed below. These products should be taken to the Service Agency for repair:

- \* The Model 510FD Fryer.
- \* The Model 526TOA Toaster Oven.
- \* The Model J4R, 4 oz. Popcorn Machine.
- \* The Model 518CMA & 526CMA Cheese Melter.
- \* The Model 12MC & 15MC & 18MCP Hot Food Merchandisers.
- \* The Model 12NCPW & 15NCPW Nacho Chip/Popcorn Warmer.
- \* All Hot Dog Equipment **except Roller Grills & Drawer Bun Warmers.**
- \* All Nacho Cheese Warmers **except Model 11WLA Series Nacho Cheese Warmer.**
- \* All Condiment Dispensers **except the Model HPD & SPD Series Dispenser.**
- \* All Specialty Food Warmers **except Model 130R, 11RW Series, and 11WSA Series.**
- \* All QCS/RCS Series Toasters **except Model QCS3 & RCS3 Series.**
- \* All Fast Steamer Models **except Direct Connect Series.**

#### ALL:

- \* Pop-Up Toasters
- \* Butter Dispensers
- \* Pretzel Merchandisers  
(Model 16PD-A Only)
- \* Pastry Display Cabinets
- \* Nacho Chip Merchandisers
- \* Accessories of any kind
- \* Sneeze Guards
- \* Pizza Ovens  
(Model PO12 Only)
- \* Heat Lamps
- \* Pumps-Manual

The foregoing warranty is in lieu of any and all other warranties expressed or implied and constitutes the entire warranty.

### FOR ASSISTANCE

Should you need any assistance regarding the Operation or Maintenance of any Star equipment; write, phone, fax or email our Service Department. In all correspondence mention the Model number and the Serial number of your unit, and the voltage or type of gas you are using.

MODEL NO. **11WLA/WSA** PART NO. **SK1439**

TITLE **WIRING DIAGRAM**

CHANGES	LTR	DATE	CHANGE	DR
A		01/19/00	REMOVED 'C' LEADS ATTACHED TO SOCKET DWD	
B		04-26-01	CHANGED POSITION OF HIGH LIMIT	MP

FINISH ~

STAR MFG. INTERNATIONAL, INC.  
10 SUNNEN DRIVE ST. LOUIS, MO 63143

DATE **7-18-96**  
LIMITS UNLESS OTHERWISE NOTED  
FRACTIONS ± 1/64 DECIMALS ± .005

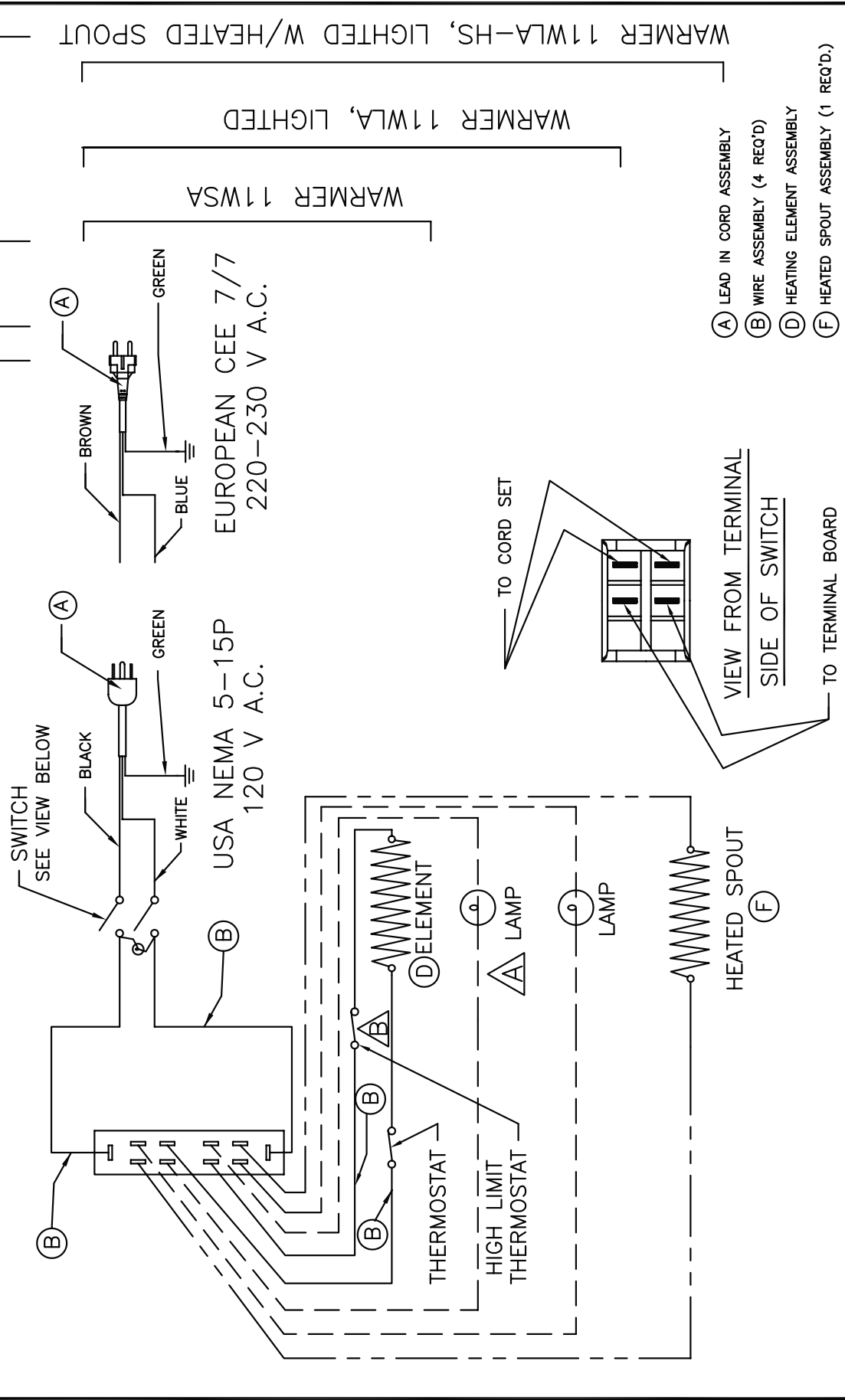

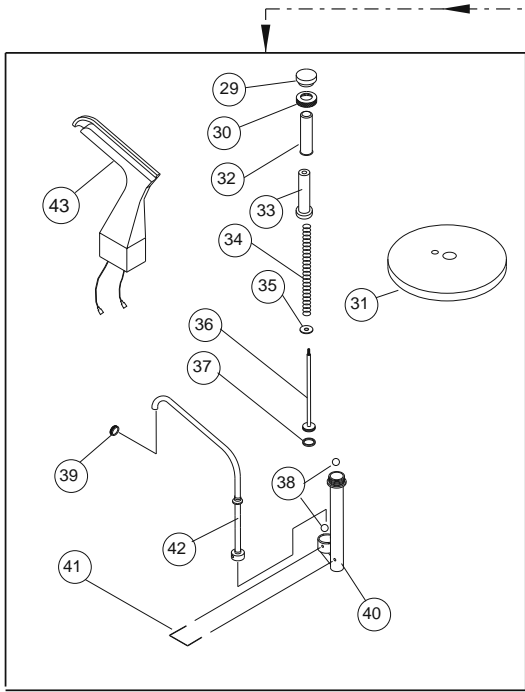

PUMP MODELS

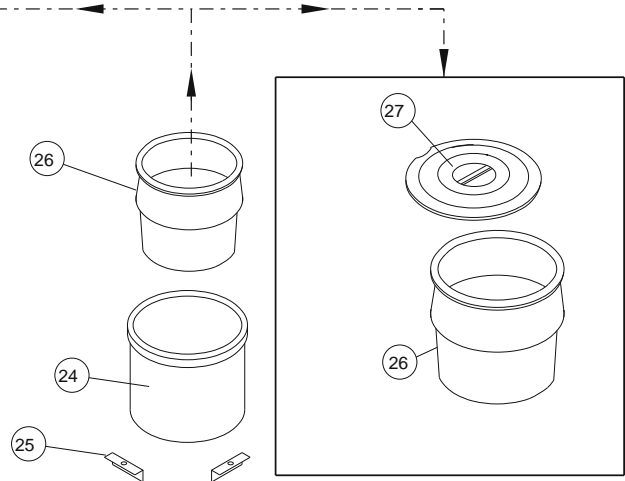

NON-PUMP MODELS

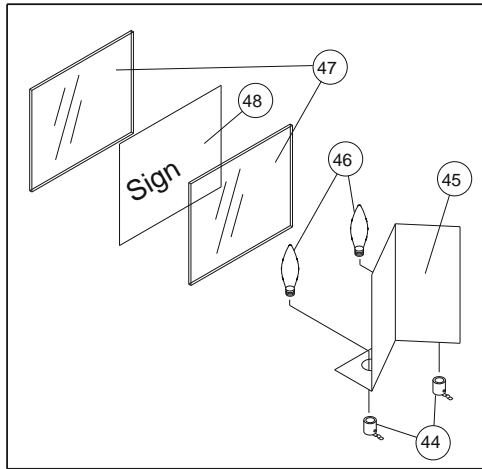

LIGHTED MODELS

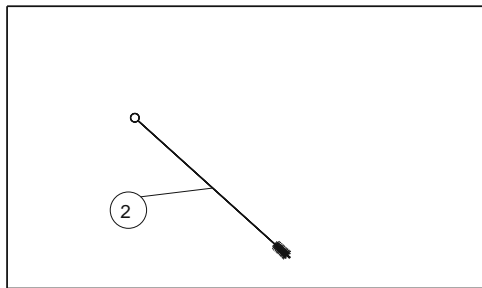

PUMP ACCESSORIES

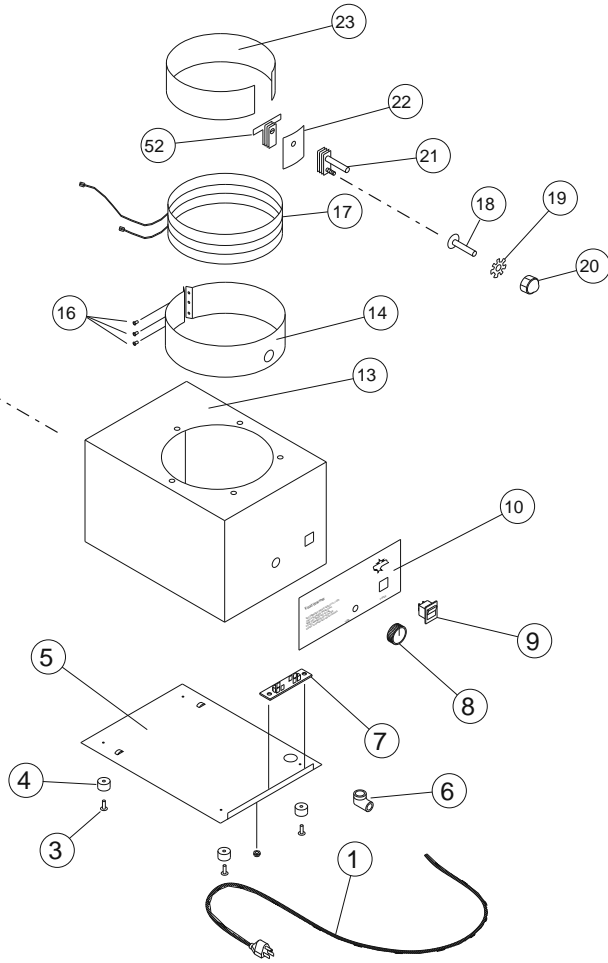

STAR MANUFACTURING INTERNATIONAL, INC.

MODEL: 11WLA- 120/240V

SK1442,

Rev. A

12-14-10



# PARTS LIST

December 13 2010, Rev. H

Model: 11WLA, 11WLA-HS, 11WLA-P				
Fig No.	Part No	Qty	Description	Application
1	N1-119030	1	CORD ASSY 120V	120V
1	N1-119033	1	CORD ASSY 120V(CSA)	C/UL
1	N1-119034	1	CORD ASSY. 240V	240V
2	2P-Y6211	1	BRUSH	11WLA-HS, 11WLA-P
3	2C-Y5059	4	POP RIVET	ALL
4	2I-Z0057	4	FOOT	ALL
5	N1-Z0697	1	BOTTOM	ALL
6	2K-Y2968	1	BUSHING STRAIN RELEIF	ALL
7	2E-Y8233	1	TERMIINAL BOARD	ALL
8	2R-Y8261	1	KNOB-THERMOSTAT	ALL
9	2E-Z5884	1	SWITCH	ALL
10	2M-Z0691	1	REAR PANEL (SIGN)	ALL
13	N1-119039	1	BODY ASSY. (WARMER)	11WLA, 11WLA-P
13	N1-119040	1	BODY ASSY. (HEATED SPOUT)	11WLA-HS
14	O1-Y9787	1	BAND-ELEMENT	ALL
16	2C-H5569	3	POP RIVET 1/8 x .6	ALL
17	2N-Z0205	1	ELEMENT 120V	120V, C/UL
17	2N-Z0665	1	ELEMENT 240V	240V
18	2C-1496	2	SCREW 8-32 x 3/4 STL. PH	ALL
19	2C-H8670	1	WASHER-LOCK #8	ALL
20	2C-2556	3	NUT #8-32	ALL
21	2T-Z0245	1	THERMOSTAT	ALL
22	N1-Z0700	1	BRACKET	ALL
23	O1-Y9786	1	BAND-HEATER	11WLA-120V
24	N1-119038	1	HEAT-WELL	11WLA-120V
25	N1-Y3654	5	ANGLE-STIFFENER	11WLA-120V
26	2D-Y3464		BOWL-INSET	ACCESSORY: SSB-11
27	2L-Y6596		COVER 11QT FORMED	ACCESSORY: SSB-11
29	2R-Y9854	1	KNOB-BLK.	11WLA-HS-120V
30	2A-Y9637	1	NUT CYLINDER SLEEVE	11WLA-HS, 11WLA-P
31	N2-Y9848	1	PLATE-PLASTIC PUMP	11WLA-HS, 11WLA-P
32	2V-Y7661	1	PLUNGER-SHIELD	11WLA-P-120V
33	2A-Z0718	1	GUIDE PLUNGER 3"	11WLA-HS, 11WLA-P
34	2P-Z0830	1	SPRING	11WLA-HS-120V
35	N2-Y4146	1	WASHER, SPRING COMPRESS TEFLN	11WLA-HS, 11WLA-P

**IMPORTANT: WHEN ORDERING, SPECIFY VOLTAGE OR TYPE GAS DESIRED  
INCLUDE MODEL AND SERIAL NUMBER**

PAGE 1  
OF 2

Some items are included for illustrative purposes only and in certain instances may not be available.



**Star Manufacturing International, Inc.**

# PARTS LIST

December 13 2010, Rev. H

Model: 11WLA, 11WLA-HS, 11WLA-P				
Fig No.	Part No	Qty	Description	Application
36	2I-Y9636	1	ROD/PLUNGER	11WLA-HS, 11WLA-P
37	2I-Y4143	1	O-RING, PISTON	11WLA-HS, 11WLA-P
38	2P-Y6196	2	BALL-VALVE	11WLA-HS, 11WLA-P
39	2A-Y7658	1	NUT-SLEEVE IN BG TUBE	11WLA-P-120V
40	2I-Z0730	1	PUMP CHAMBER	11WLA-HS-120V
41	2A-Y9685	1	PIN-"U"	11WLA-HS, 11WLA-P
42	2V-62006	1	DISPENSE TUBE ASSEMBLY STANDARD	11WLA-HS, 11WLA-P
43	N1-119041	1	SPOUT ASSY. 240V	11WLA-HS-240V
43	N1-119044	1	SPOUT ASSY. 120V, used w/2N-Y4440 SPOUT ELEM HEATER	11WLA-HS-120V, 11WLA-HSC/UL
44	N2-30457	2	SOCKET ASSY 2 PO 18" LEAD	ALL
45	N1-119029	1	LAMP SHIELD 120V/240V	11WLA-120V
46	2S-1279	2	LAMP 15W 120V	120V
46	2S-Y8321	2	LAMP 15W 220V	240V
47	2Q-Z0729	2	LEXAN PANEL	11WLA-120V
48	2M-Y9414	1	PACKET (5 SIGNS)	11WLA-120V
52	2T-Z0622	1	THERMOSTAT (HIGH LIMIT)	11WLA-120V
NI	N2-61007		PUMP ASSY COMPLETE	11WLA-HS, 11WLA-P

**IMPORTANT: WHEN ORDERING, SPECIFY VOLTAGE OR TYPE GAS DESIRED  
INCLUDE MODEL AND SERIAL NUMBER**

PAGE 2  
OF 2

Some items are included for illustrative purposes only and in certain instances may not be available.



**Star Manufacturing International, Inc.**

# CLEANING INSTRUCTIONS

BEFORE USING AND AT LEAST DAILY, DISASSEMBLE THE PUMP AND WASH ALL PARTS.

## TO DISASSEMBLE PUMP:

1. UNSCREW NUT-CYLINDER(2). PULL PUMP-PLUNGER(8) FROM PUMP CHAMBER (14).
2. UNSCREW KNOB(1) FROM PLUNGER ASSY. AND DISASSEMBLE.
3. UNSCREW CAP-TUBE(11) & NUT-SLEEVE-TUBE(10) FROM DISPENSE TUBE. REMOVE COVER(3) FROM PUMP ASSEMBLY.
4. REMOVE PIN "U"(15) FROM PUMP ASSY. AND DISENGAGE DISPENSE TUBE(18) FROM PUMP CHAMBER(14).
5. REMOVE BALLS(13) FROM PUMP CHAMBER(14).
6. WASH ALL PARTS THOROUGHLY IN HOT SOAPY WATER AND RINSE THOROUGHLY. USE 18" LONG BRUSH(17) TO CLEAN INSIDE OF DISPENSING TUBE(18). REASSEMBLE PUMP. WHEN REASSEMBLING PUMP, WET O-RING(9) WITH EDIBLE VEGETABLE OIL, THEN REASSEMBLE. MAKE SURE ALL PARTS ARE IN THEIR PROPER PLACE.

## PARTS LIST

ITEM	DESCRIPTION
1.	KNOB - RED, YELLOW OR BLACK*
2.	NUT-CYLINDER
3.	COVER - FLAT OR DOME SHAPED
4.	SHIELD-PLUNGER
5.	GUIDE-PLUNGER
6.	SPRING
7.	WASHER
8.	ROD/PLUNGER
9.	O-RING
10.	NUT-SLEEVE-TUBE
11.	CAP-TUBE*
12.	GASKET*
13.	BALL
14.	PUMP CHAMBER - 5", 8" OR 9"
15.	PIN "U"
16.	EXTENSION
17.	BRUSH
18.	DISPENSE TUBE ASSEMBLY

\* INDICATES PART NOT INCLUDED ON ALL MODELS

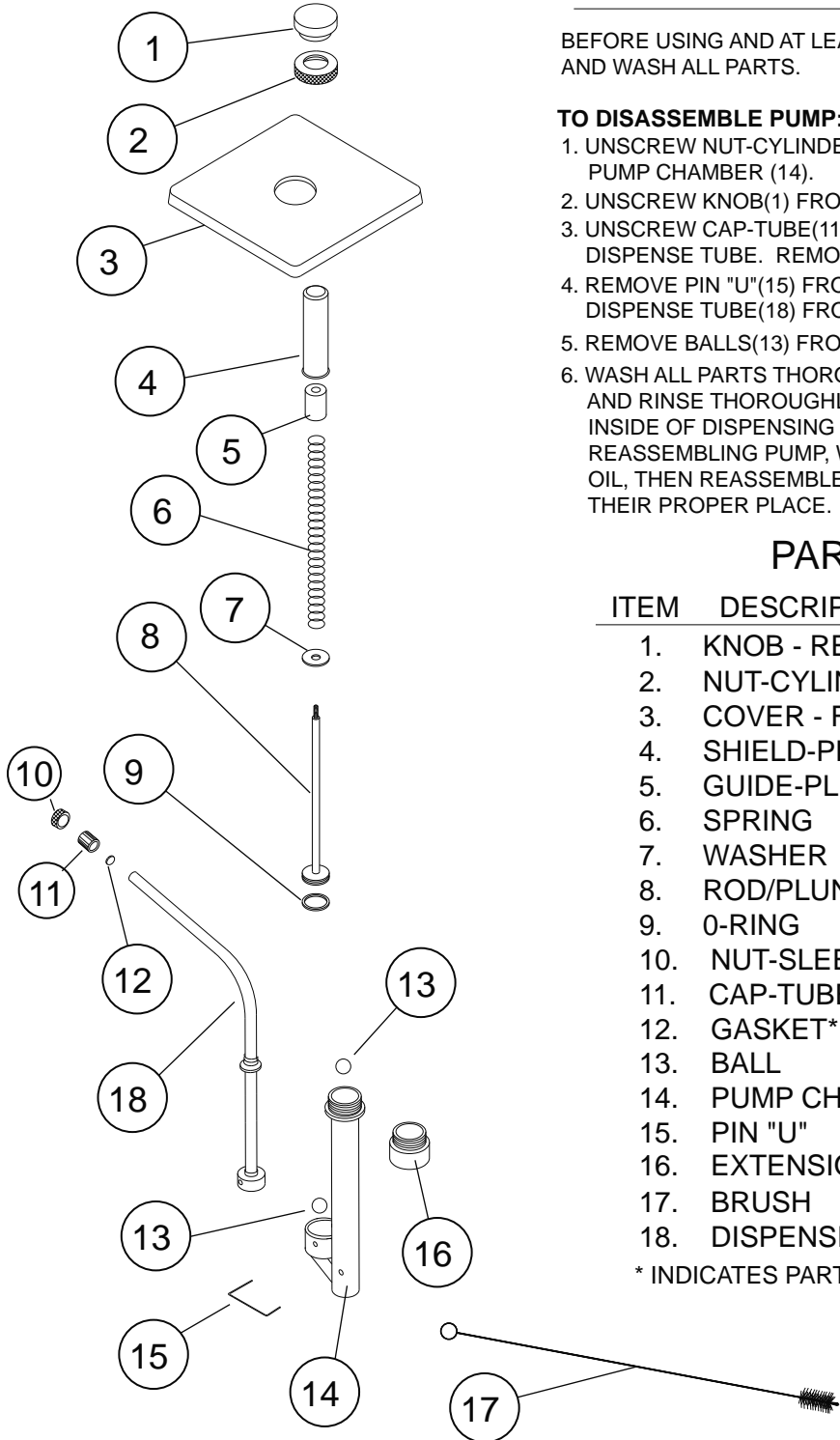

ALL MODELS  
PUMP

STAR MANUFACTURING INTERNATIONAL, INC.  
REV. C, 12/6/95

2M-Y8900

STAR INTERNATIONAL HOLDINGS INC. COMPANY  
Star - Holman - Lang - Wells - Bloomfield - Toastmaster  
10 Sunnen Drive, St. Louis, MO 63143 U.S.A.  
(314) 678-6314  
[www.star-mfg.com](http://www.star-mfg.com)