



Model 100C / 100F / 2217G
SERVICE MANUAL
Manual No. 513554

This manual provides basic information about the machine. Instructions and suggestions are given covering its operation and care.

The illustrations and specifications are not binding in detail. We reserve the right to make changes to the machine without notice, and without incurring any obligation to modify or provide new parts for machines built prior to date of change.

DO NOT ATTEMPT to operate the machine until instructions and safety precautions in this manual are read completely and are thoroughly understood. If problems develop or questions arise in connection with installation, operation, or servicing of the machine, contact Stoelting.



stoeltingfoodservice.com

Stoelting Foodservice Equipment
502 Highway 67
Kiel, WI 53042-1600
U.S.A.

Main Tel: 800.558.5807
Fax: 920.894.7029

Customer Service: 888.429.5920
Fax: 800.545.0662
Email: foodservice@stoelting.com

© 2014 PW Stoelting, LLC

A Few Words About Safety

Safety Information

Read and understand the entire manual before operating or maintaining Stoelting equipment.

This manual provides the operator with information for the safe operation and maintenance of Stoelting equipment. As with any machine, there are hazards associated with their operation. For this reason safety is emphasized throughout the manual. To highlight specific safety information, the following safety definitions are provided to assist the reader.

The purpose of safety symbols is to attract your attention to possible dangers. The safety symbols, and their explanations, deserve your careful attention and understanding. The safety warnings do not by themselves eliminate any danger. The instructions or warnings they give are not substitutes for proper accident prevention measures.

If you need to replace a part, use genuine Stoelting parts with the correct part number or an equivalent part. We strongly recommend that you do not use replacement parts of inferior quality.



Safety Alert Symbol:

This symbol Indicates danger, warning or caution. Attention is required in order to avoid serious personal injury. The message that follows the symbol contains important information about safety.

Signal Word:

Signal words are distinctive words used throughout this manual that alert the reader to the existence and relative degree of a hazard.



The signal word "WARNING" indicates a potentially hazardous situation, which, if not avoided, may result in death or serious injury and equipment/property damage.



The signal word "CAUTION" indicates a potentially hazardous situation, which, if not avoided, may result in minor or moderate injury and equipment/property damage.

CAUTION

The signal word "CAUTION" not preceded by the safety alert symbol indicates a potentially hazardous situation, which, if not avoided, may result in equipment/property damage.

NOTE (or NOTICE)

The signal word "NOTICE" indicates information or procedures that relate directly or indirectly to the safety of personnel or equipment/property.

TABLE OF CONTENTS

SECTION	DESCRIPTION	PAGE
SECTION 1	INTRODUCTION	1
1.1	Descriptions	1
1.2	Specifications	1
SECTION 2	INSTALLATION INSTRUCTIONS	3
2.1	Safety Precautions	3
2.2	Shipment and Transit	3
2.3	Freezer Installation	3
2.4	Adjusting Cup Dispensers	7
SECTION 3	INITIAL SET-UP AND OPERATION	9
3.1	Operator's Safety Precautions	9
3.2	Operating Controls and Indicators	9
3.3	Draining the Freezer For Disassembling and Cleaning	10
3.4	Disassembly and Cleaning of Freezer Parts	10
3.5	Sanitizing The Freezers and Freezer Parts	15
3.6	Assembly of Freezer	15
3.7	Mix Information	17
3.8	Freeze Down and Operation	17
3.9	Dispensing Product	17
3.10	Routine Cleaning	17
3.11	Preventative Maintenance	17
3.12	Extended Storage	18
SECTION 4	DECALS AND TAGS	21
4.1	How to Order Decals and Tags	21
SECTION 5	REFRIGERATION COMPONENTS AND ADJUSTMENTS	23
5.1	Refrigeration System	23
5.2	Compressor	23
5.3	Condenser	23
SECTION 6	ELECTRICAL SYSTEM OPERATION AND ADJUSTMENTS	27
6.1	24 Hour Timer	27
6.2	Electronic Torque Control	27
SECTION 7	MAJOR COMPONENT REMOVAL AND INSTALLATION	29
7.1	Introduction	29
7.2	Condenser Fan Removal	29
7.3	Drive Motor Removal	29
7.4	Compressor Removal	29
7.5	Compressor Installation	30
7.6	Drive Motor Installation	31
7.7	Condenser Fan Installation	31
SECTION 8	TROUBLESHOOTING	33
8.1	Compressor Run Capacitor Open, Shorted or Blown	34
8.2	Compressor Relay Defective or Burned Out	34
8.3	Compressor Starts and Runs, But Short Cycles On Overload Protector	34
8.4	Compressor Runs Continuously	34
8.5	Unit Noisy	34
8.6	Compressor Will Not Start	34
8.7	Compressor Will Not Start - Hums But Trips On Overload Protector	35
8.8	Compressor Starts, But Does Not Switch Off of Start Winding	35

TABLE OF CONTENTS

8.9	Compressor Start Capacitor Open, Shorted or Blown	35
8.10	Freezer Will Not Start	35
8.11	Drive Motor Overload Trips (Freezer Shuts Down When Running)	35
8.12	Compressor Will Not Run, But Drive Motor Runs	35
8.13	Product Dispenses Incorrectly	35
8.14	Product is Too Thin	36
8.15	Agitator Does Not Rotate	36
8.16	No Ice Crystals On Initial Freeze Down	36
8.17	Excessive Ice Crystals Above Divider Plate	36
8.18	Spigot Leaking or Stuck	36
SECTION 9	REPLACEMENT PARTS AND REFERENCE DRAWINGS	37
9.1	How to Order Parts	37
9.2	Spigot Assembly Parts	37
9.3	Model 100C Parts List	39
9.4	Model 100F Parts List	41
9.5	Model 2217G Parts List	43

LIST OF ILLUSTRATIONS

Figure	Title	Page
1	Model 100C - Front	2
2	Model 100C - Side	2
3	Model 100F/2217G - Front	2
4	Model 100F/2217G - Side	2
5	Adjustable Leg	3
6	Warning Label Locations - 100C	4
7	Warning Label Locations - 100F/2217G	5
8	Space & Ventilation Requirements	6
9	Electrical Plug	6
10	Installing Sani-tray and Cover	6
11	Adjusting Cup Dispensers	7
12	Operating Controls	9
13	Remove Sani-tray and Cover	11
14	Draining Product	11
15	Removing Spigot Assembly	12
16	Removing Spigot O-Ring from Spigot Body	12
17	Cut-away View of Spigot Assembly	12
18	Removing Drive Cap and O-Ring	13
19	Removing Sealer Ring	13
20	Removing Agitator Assembly and Lower Bushing	13
21	Removing Divider Plate from Agitator Fingers	14
22	Removing Drive Shaft	14
23	Exploded View of Divider plate and Agitator Assembly	14
24	Lubricating Drive Shaft	15
25	Installing Divider Plate and Agitator Assembly	16
26	Proper Installation of Sealer Ring	16
27	Correct and Incorrect Alignment of Vertical Center Post Guide Hole	16
28	External Parts To Be Cleaned	19

LIST OF ILLUSTRATIONS

30	Removing Compressor Terminal Cover	23
31	Check Winding	23
32	Check Winding To Ground	23
33	Check Condenser	24
34	Remove Cap	24
35	Install Gauge	25
36	Adjust A.X.V.	25
37	Filter Drier Replacement	26
38	Torque Control	27
39	Tension Spring	27
40	Removing Torque Control	28
41	Fan Removal	29
42	Disconnect Wire	29
43	Drive Motor Removal	29
44	Compressor Removal	30
45	Install Compressor	30
46	Remove Filter Drier	31
47	Tension Spring	31
48	Fan Installation	31
49	Exploded View of Spigot Assembly	37
50	Model 100C Exploded View	38
51	Model 100F Exploded View	40
52	Model 2217G Exploded View	42

SECTION 1 INTRODUCTION

1.1 DESCRIPTION

Models 100C, 100F, and 2217G freezers are gravity fed. The freezers are equipped with fully automatic controls to provide a uniform product. The freezers are designed to operate with most neutral bases and concentrated flavors.

This manual is designed to assist qualified service personnel and operators in the installation, operation and maintenance of the Models 100C, 100F, and 2217G freezers.

1.2 SPECIFICATIONS

	100C COUNTER MODEL FREEZER	100F FLOOR MODEL FREEZER	2217G FLOOR MODEL FREEZER
DIMENSIONS	width: 15" (38.1 cm) depth: 29.5" (74.8 cm) height: 34.75" (88.3 cm)	width: 15" (38.1 cm) depth: 19.25" (48.9 cm) height: 61.38" (156 cm)	width: 15" (38.1 cm) depth: 19.25" (48.9 cm) height: 61.38" (156 cm)
WEIGHT	130 lbs. (58.9 kg)	140 lbs. (63.5 kg)	140 lbs. (63.5 kg)
ELECTRICAL	1 Phase, 115 VAC* 1/12 HP Drive Motor	1 Phase, 115 VAC* 1/12 HP Drive Motor	1 Phase, 115 VAC* 1/12 HP Drive Motor
COMPRESSOR	2500 BTUH** (frozen product output) - Approx. 11 total running amps. Use 15 Amp circuit breaker	2500 BTUH** (frozen product output) - Approx. 11 total running amps. Use 15 Amp circuit breaker	5200 BTUH** (frozen product output) - Approx. 9 total running amps. Use 15 Amp circuit breaker
COOLING	Air cooled requires minimum 3" (7.6 cm) air clearance on sides and 1" (2.5 cm) at rear of unit.	Requires unobstructed front and 6" minimum (15.2 cm) clearance at back of unit. No clearance needed on side of unit.	Requires unobstructed front and 6" minimum (15.2 cm) clearance at back of unit. No clearance needed on side of unit.
HOPPER	10 gallons (37.9 liters)	10 gallons (37.9 liters)	10 gallons (37.9 liters)

* A transformer is required if voltage is over 126.5 volts or under 103 volts.

** Under normal operating conditions.

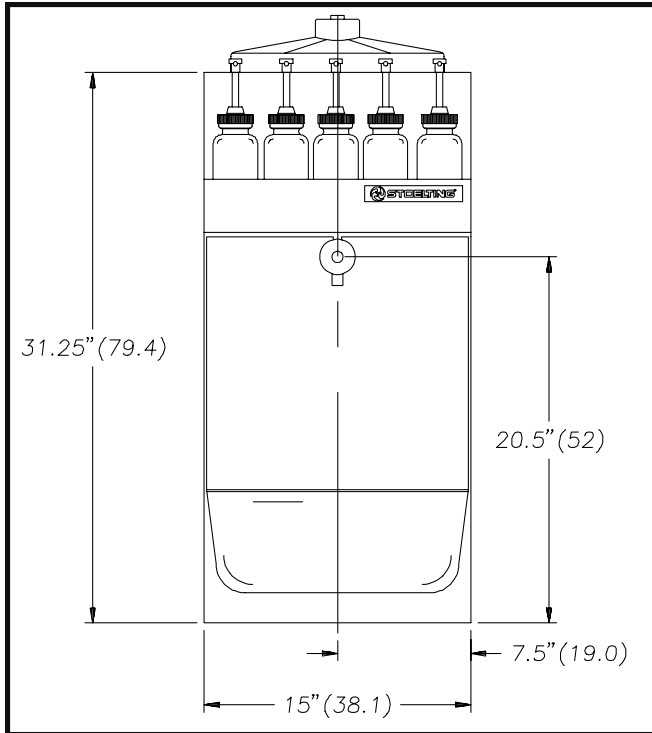

Figure 1
Model 100C - Front

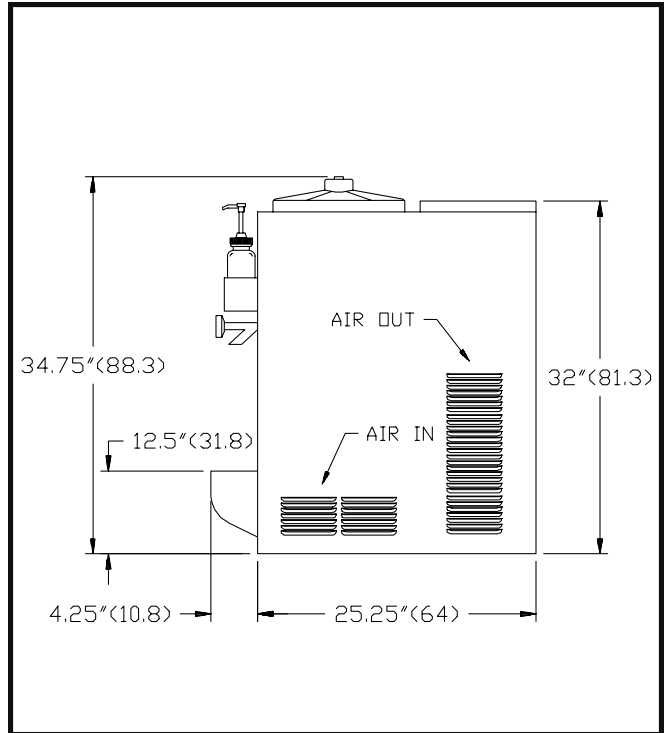

Figure 2
Model 100C - Side

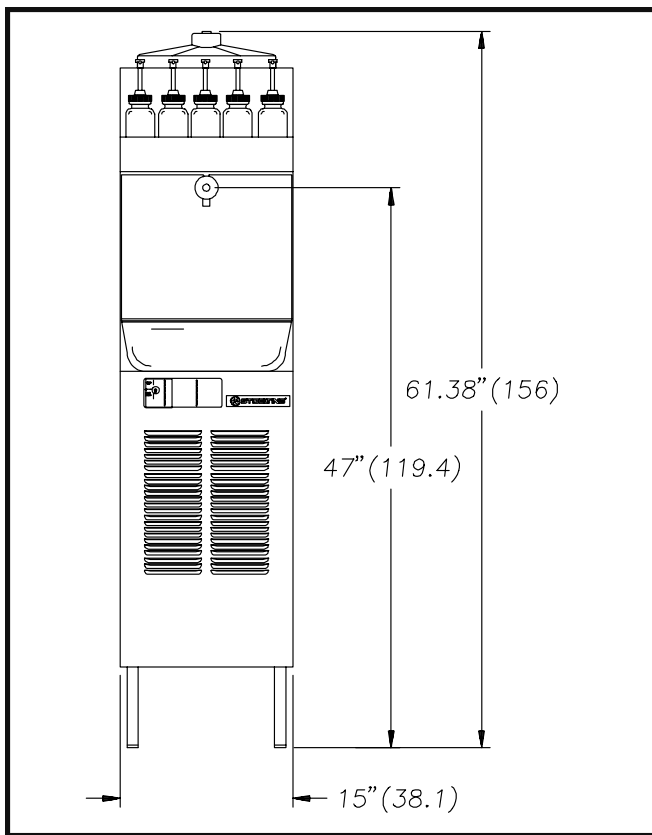

Figure 3
Model 100F/2217G - Front

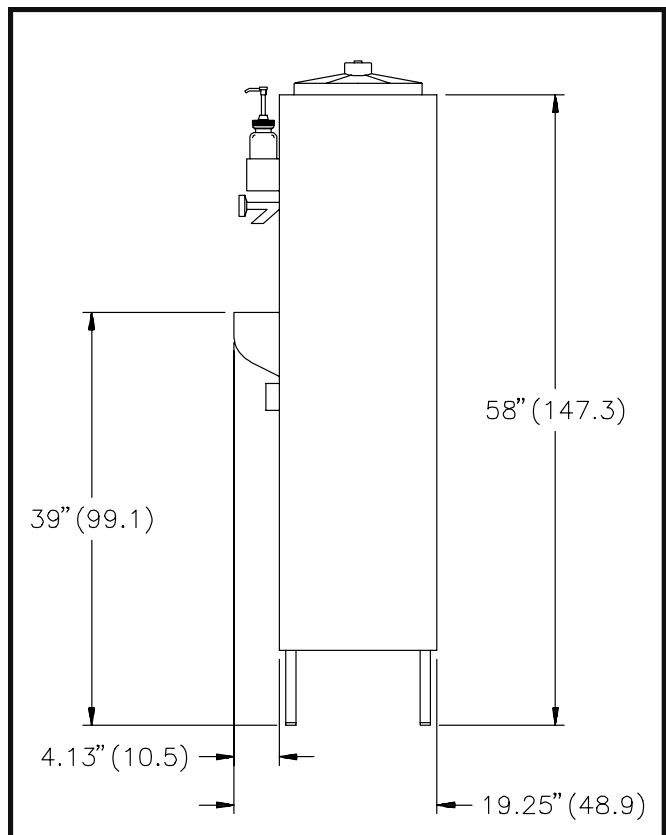

Figure 4
Model 100F/2217G - Side

NOTE: Figures in parenthesis are in centimeters.

SECTION 2 INSTALLATION INSTRUCTIONS

2.1 SAFETY PRECAUTIONS

Do not attempt to operate the freezer until the safety precautions and operating instructions in this manual are read and completely understood.

Take notice of all warning labels on the freezer (Figures 6 & 7). The labels have been put there to help maintain a safe working environment. The labels have been designed to withstand washing and cleaning. All labels must remain legible for the life of the freezer. Labels should be checked periodically to be sure they can be recognized as warning labels.

If danger, warning, or caution labels are needed, indicate the part number, type of label, location of label, and quantity required along with your address and advise your distributor.

2.2 SHIPMENT AND TRANSIT

The freezer has been assembled, operated and inspected at the factory. Upon arrival at the final destination, the complete freezer must be checked for any damage which may have occurred during transit.

With the method of packaging used, the freezer should arrive in excellent condition. **THE CARRIER IS RESPONSIBLE FOR ALL DAMAGE IN TRANSIT, WHETHER VISIBLE OR CONCEALED.**

Do not pay the freight bill until the freezer has been checked for damage. Have the carrier note any visible damage on the freight bill. If concealed damage and/or shortage is found later, advise the carrier within 10 days and request inspection. The customer must place claim for damages and/or shortages in shipment with the carrier.

2.3 FREEZER INSTALLATION

Installation of the freezer involves moving the freezer close to its permanent location, removing all crating, setting in place, assembling parts, and cleaning.

- A. Uncrate the freezer.
- B. The floor model freezers must be placed in a solid level position. To level the freezer, turn the bottom part of each leg in or out. Place a level on top of the hopper, with the cover removed, to check whether or not the freezer is level (Fig. 5).

NOTE

Accurate leveling is necessary for correct drainage of freezer barrel and to insure proper operation.

- C. The counter model freezer must be placed on a solid level surface. Place the rubber pad furnished under the freezer to create a seal to that surface. The counter model freezer is air-cooled and discharges at the top. **AL LOUVERED PANELS MUST** have 3" of clearance on sides of unit, 10" of clearance at the top, and 1" clearance at rear of unit for proper cooling.

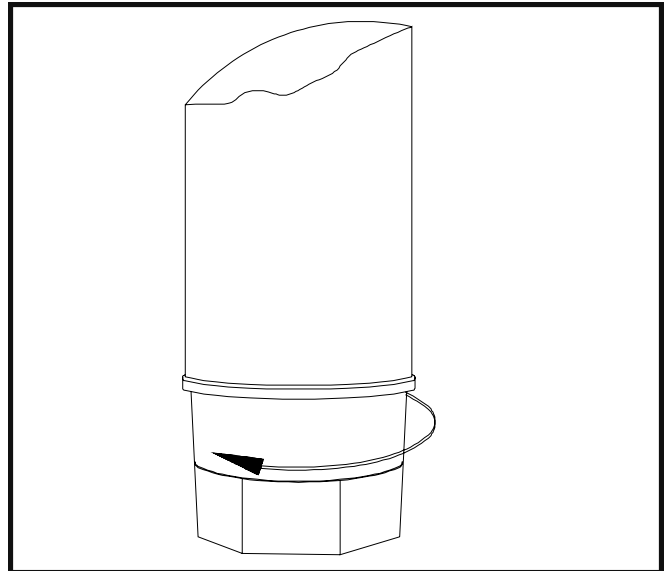

**Figure 5
Adjustable Leg**

IMPORTANT NOTICE TO OPERATOR

BEFORE INSTALLING EQUIPMENT, READ THE OWNER'S MANUAL CAREFULLY. TAKE NOTE OF ALL INSTRUCTIONS AND CAUTION DECALS ON THIS EQUIPMENT.

GO OVER THE MANUAL THOROUGHLY AND POINT OUT ALL DECALS TO YOUR EMPLOYEES, SO THEY UNDERSTAND HOW TO SAFELY OPERATE THIS EQUIPMENT.

DO NOT REMOVE, DEFACE, OR PAINT OVER ANY DECALS. THEY ARE THERE FOR YOUR SAFETY.

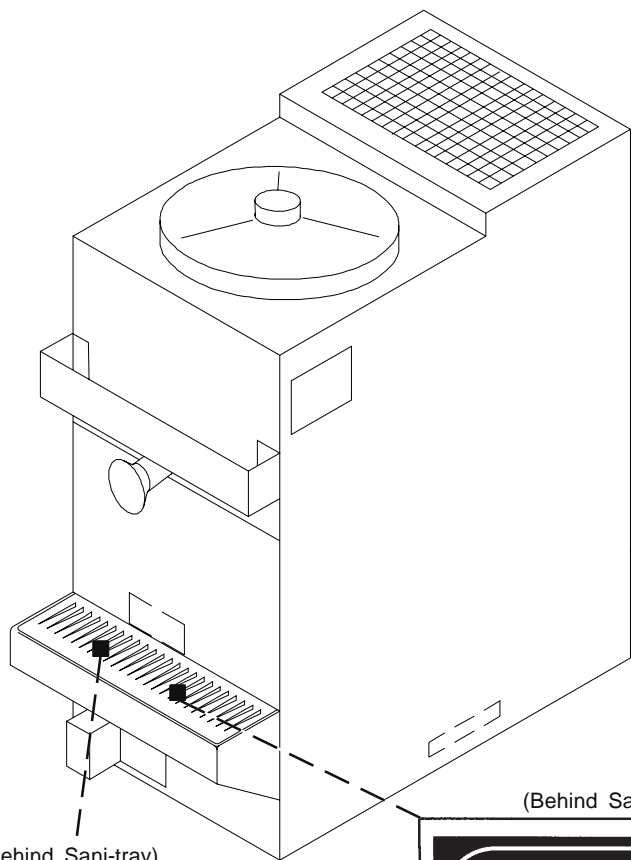

CAUTION
THIS DEVICE MUST BE PLUGGED INTO A GROUNDED RECEPTACLE TO PREVENT SHOCK HAZARD.
324113

(Behind Sani-tray)

CAUTION
HAZARDOUS MOVING PARTS
DO NOT OPERATE UNIT WITH OUTER COVERING REMOVED.
324107

(Behind Sani-tray)

DANGER
ELECTRIC SHOCK HAZARD
DISCONNECT FROM THE SOURCE OF ELECTRICAL SUPPLY IN BUILDING BEFORE SERVICING UNIT
324105

CAUTION
THIS DEVICE MUST BE PLUGGED INTO A PROPERLY GROUNDED RECEPTACLE TO PREVENT ELECTRICAL SHOCK HAZARD.

TAMPERING WITH THE PLUG OR USING VOLTAGES OTHER THAN THE SPECIFICATIONS ON I.D. PLATE WILL VOID YOUR WARRANTY.

REFER TO OWNER'S MANUAL FOR INSTALLATION INSTRUCTIONS.
723529

Figure 6
Warning Label Locations - 100C

IMPORTANT NOTICE TO OPERATOR

BEFORE INSTALLING EQUIPMENT, READ THE OWNER'S MANUAL CAREFULLY. TAKE NOTE OF ALL INSTRUCTIONS AND CAUTION DECALS ON THIS EQUIPMENT.

GO OVER THE MANUAL THOROUGHLY AND POINT OUT ALL DECALS TO YOUR EMPLOYEES, SO THEY UNDERSTAND HOW TO SAFELY OPERATE THIS EQUIPMENT.

DO NOT REMOVE, DEFACE, OR PAINT OVER ANY DECALS. THEY ARE THERE FOR YOUR SAFETY.

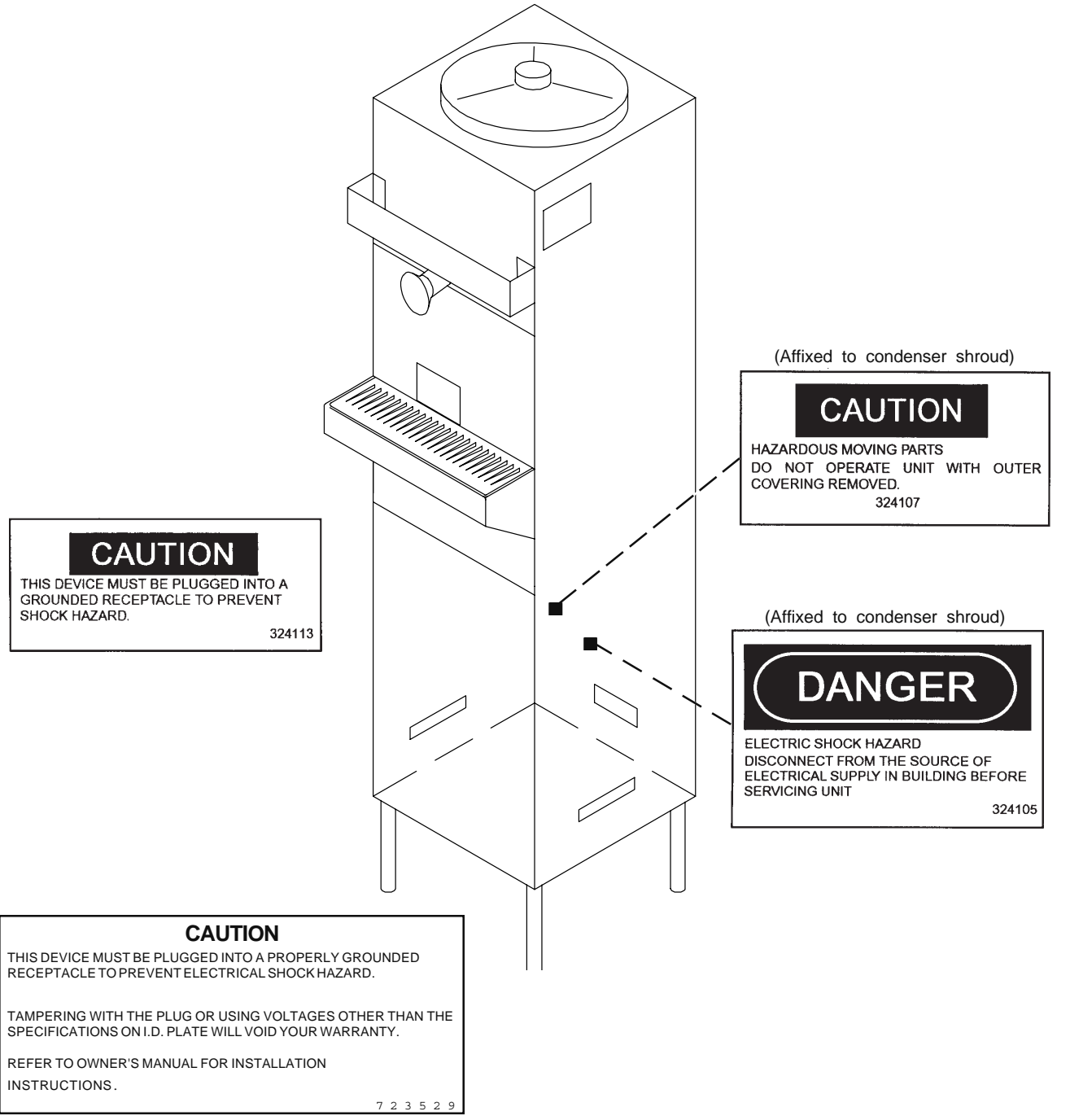

Figure 7
Warning Label Locations - 100F/2217G

D. The floor model freezers are equipped with air-cooled condensers and require correct ventilation. The front of the freezer is the air intake and must be unobstructed. Air discharges out of the rear of the unit. Do not obstruct the discharge. Allow a 6" (15.2 cm) clearance behind the unit (Fig. 8).

CAUTION
FAILURE TO PROVIDE ADEQUATE VENTILATION WILL VOID WARRANTY!

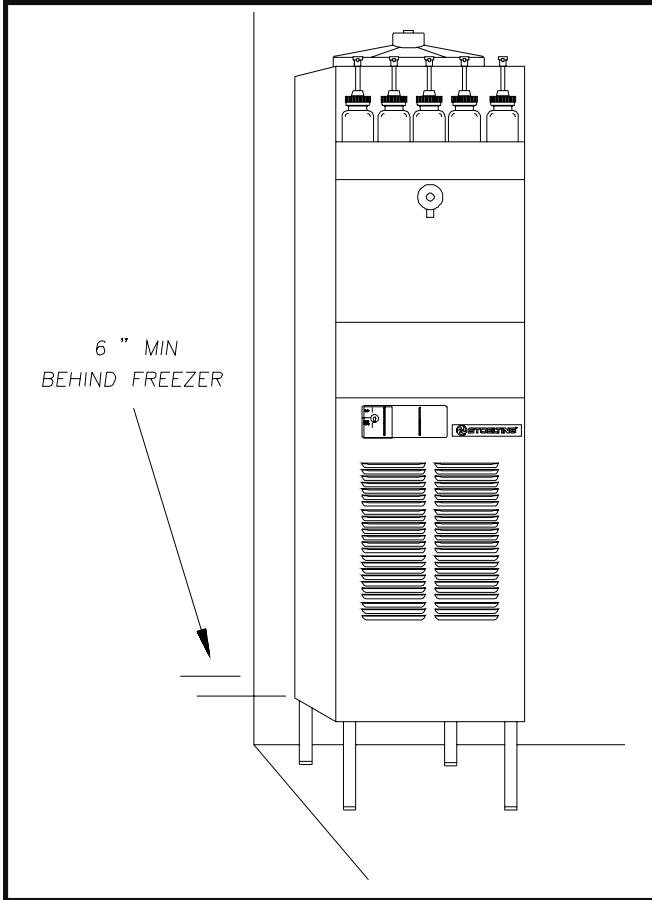

Figure 8
Space and Ventilation Requirements

E. Place the ON-OFF-STIR ONLY toggle switch in the OFF position. This switch is located on the lower left of the freezer, under the drip tray and cover.

F. Connect the power cord. The plug is designed for 115 volt/15 amp duty. The unit must be connected to a properly grounded receptacle. The electrical cord furnished as part of the freezer has a three prong grounding type plug (Fig.9). The use of an extension cord is not recommended. If one must be used, use one with a wire, size 12 gauge or heavier, with a ground. Do not use an adaptor to avoid grounding equipment.

CAUTION
DO NOT ALTER OR DEFORM PLUG IN ANY WAY!

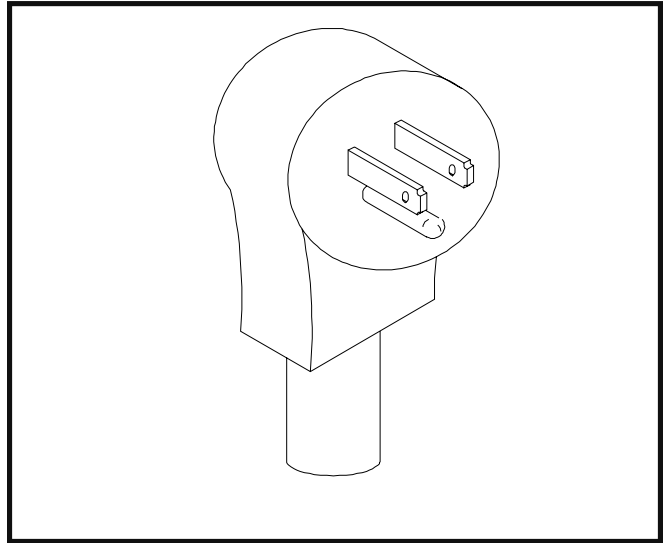

Figure 9
Electrical Plug

G. Install the sani-tray, cover and miscellaneous parts on the freezer (Fig. 10).

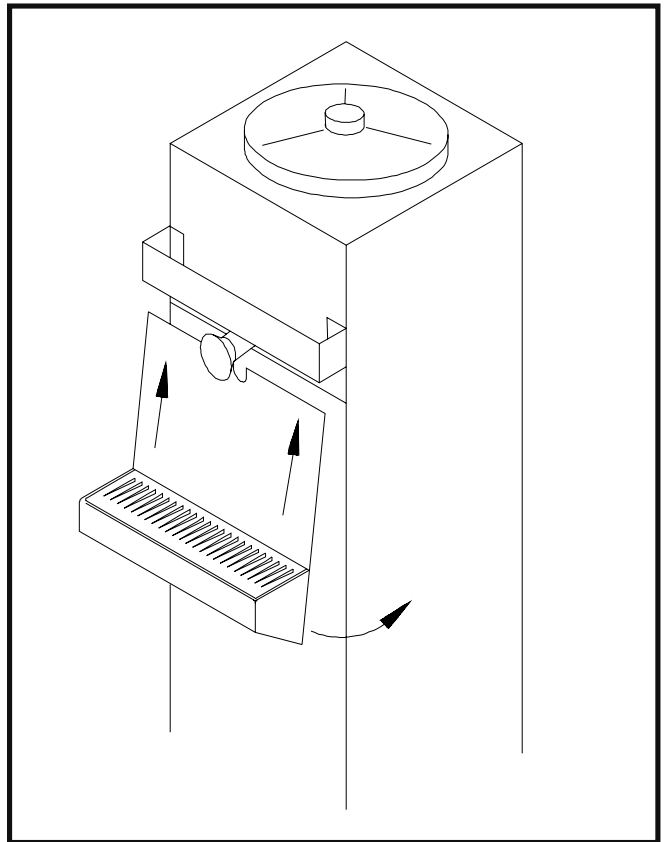

Figure 10
Installing Sani-tray and Cover

2.4 ADJUSTING CUP DISPENSERS

To adjust the cup dispensers, install the size cup desired into the dispenser and turn the wing nuts on the dispenser mounting bracket until enough tension is applied to the rim of the cup to keep it from dropping out (Fig. 11). Do not over-tighten the wing nuts.

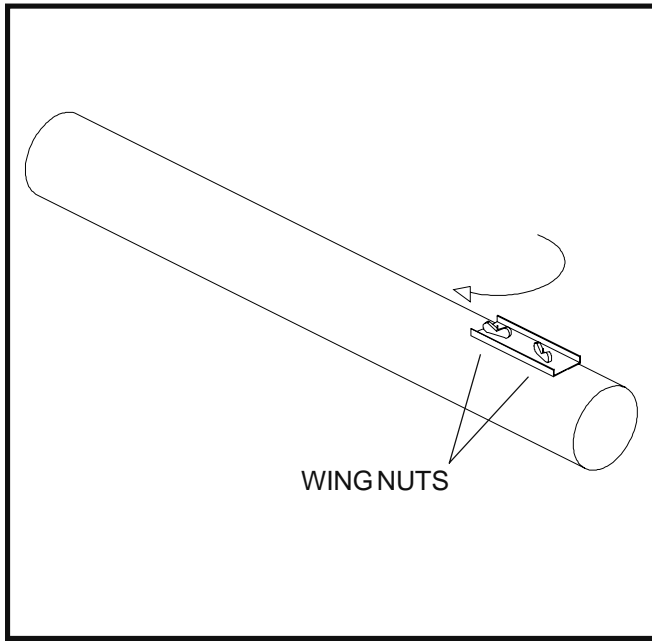

Figure 11
Adjusting Cup Dispensers

SECTION 3 INITIAL SET-UP AND OPERATION

3.1 OPERATOR'S SAFETY PRECAUTIONS

- A. Know the freezer. Read and understand the Operating Instructions.
- B. Notice all warning labels on the freezer.
- C. Wear proper clothing. Avoid loose fitting garments, and remove watches, rings or jewelry which could cause a serious accident.
- D. Maintain a clean work area. Avoid accidents by cleaning up the area and keeping it clean.
- E. Stay alert at all times. Know which switch, push-button or control you are about to use and what effect it is going to have.
- F. Disconnect electrical cord for maintenance. Never attempt to repair or perform maintenance on the freezer until the main electrical power has been disconnected.

- G. Do not operate under unsafe operating conditions. Never operate the freezer if unusual or excessive noise or vibration occurs.

3.2 OPERATING CONTROLS AND INDICATORS

Before operating the freezer, it is required that the operator know the function of each operating control and indicator. Refer to Figure 12 for the locations of the operating controls and indicators.

WARNING

THE STIRRING ONLY-OFF-STIRRING & FREEZING SWITCH MUST BE PLACED IN THE OFF POSITION WHEN DISASSEMBLING FOR CLEANING OR SERVICING. THE FREEZER MUST BE DISCONNECTED FROM ELECTRICAL SUPPLY BEFORE REMOVING ANY ACCESS PANELS. ONLY A QUALIFIED SERVICE TECHNICIAN MAY REMOVE ACCESS PANELS.

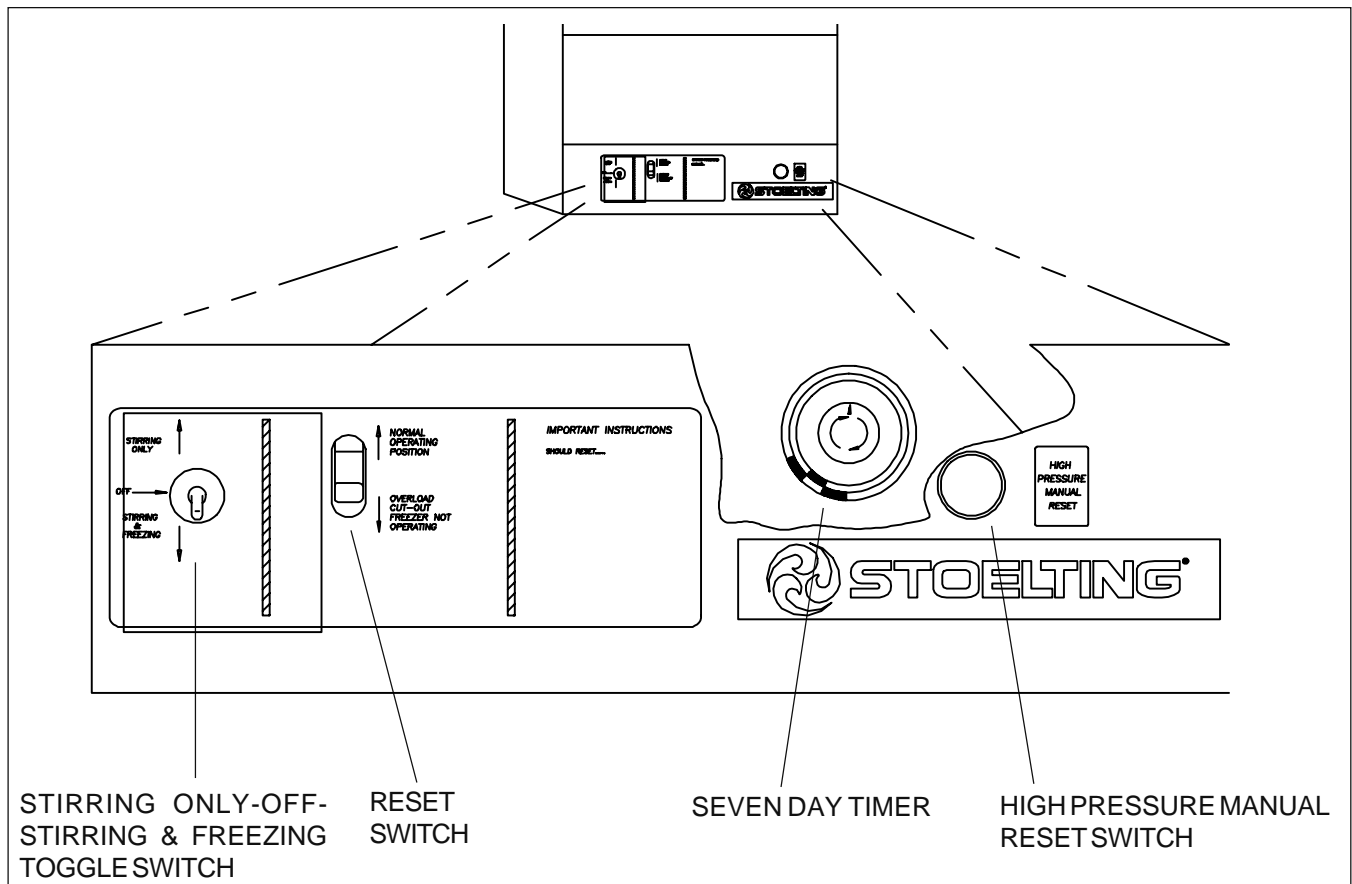

**Figure 12
Operating Controls**

A. STIRRING ONLY-OFF-STIRRING & FREEZING SWITCH

The STIRRING ONLY-OFF-STIRRING & FREEZING switch is a three-position toggle switch used to control the operation of the refrigeration system and agitator. When the switch is placed in the STIRRING ONLY position, the refrigeration system will be off and the agitator will rotate for cleaning, or if stirring is required when the store is closed. When the switch is placed in the OFF position, the refrigeration system and agitator will be off. The switch should be placed in the STIRRING & FREEZING position for normal operation.

B. RESET SWITCH

The reset switch is a two-position breaker switch. This switch is used to protect the freezer from mechanical damage. The switch must be in the NORMAL OPERATING POSITION (up) before the freezer will operate.

Any time a condition occurs which causes the agitator drive motor to draw excessive current, the reset switch will automatically switch to the OVERLOAD CUT-OUT FREEZER NOT OPERATING position. This will shut down the freezing and agitation action of the freezer to protect the agitator drive motor from burning out.

Should the reset switch ever trip out, move the STIRRING ONLY-OFF-STIRRING & FREEZING toggle switch to the STIRRING ONLY position. Then move the reset switch back to NORMAL OPERATING POSITION (up) and allow the freezer to stir, without refrigeration, for five minutes. After five minutes of stirring, return the STIRRING ONLY-OFF-STIRRING & FREEZING switch to the STIRRING & FREEZING position.

C. 24 HOUR TIMER

To program the timer, rotate program disc in the direction of the arrows to align the correct day/time with the time of day mark. Then pull out for Off time or push in for On time. Each actuator is equivalent to 15 minutes time. Check for AM/PM centered between 12 and 12 on rotating disc. At a 6:00 setting the indicator will point to AM or PM.

D. HIGH PRESSURE MANUAL RESET SWITCH

The HIGH PRESSURE MANUAL RESET SWITCH is a safety switch designed to protect the compressor from damage due to excessive head pressure. When tripped, the lever will be out; push to reset.

E. SPIGOT ASSEMBLY

Dispensing of frozen mix is done by the SPIGOT ASSEMBLY. By pulling the spigot plunger out, mix in the form of ice crystals is dispensed through the port on the bottom of the SPIGOT ASSEMBLY. To stop dispensing, push the spigot plunger in.

F. FLAVOR BOTTLES

The FLAVOR BOTTLES are operated by a spring loaded, push-button pump. By pushing down, 1/4 ounce (7.39 ml) of flavor is dispensed.

3.3 DRAINING THE FREEZER FOR DISASSEMBLING AND CLEANING

After installation and initial set-up, the freezer exterior must be cleaned and the freezer parts must be disassembled, cleaned and sanitized. Cleaning and sanitizing MUST be done before the initial freeze down and operation.

Subsequent cleaning and sanitizing, after the freezer has been operated and product has been dispensed, will require the freezer to be completely drained of all unused mix. Perform the following steps to drain the freezer of any unused mix:

- A. Set the STIRRING ONLY-OFF-STIRRING & FREEZING switch to the STIRRING ONLY position well in advance of cleaning and sanitizing to assure complete defrosting and draining of the product cylinder.
- B. While the freezer is in the STIRRING ONLY mode, remove the unused flavoring from the flavor bottles. All unused flavoring should be poured into the containers from which they came.
- C. Remove the Sani-tray and cover by gently pushing up to disengage from the support pins and pulling out and down (Fig. 13).
- D. With a bucket placed below the drain spigot, pull the spigot to dispense (Fig. 14).
- E. When liquid product is completely drained, empty the bucket into the sink. Any remaining ice can be removed by circulating warm water through barrel.

3.4 DISASSEMBLY AND CLEANING OF FREEZER PARTS

CAUTION

PLACE THE ON-OFF-STIR ONLY SWITCH IN THE OFF POSITION AND DISCONNECT THE FREEZER FROM ELECTRICAL SUPPLY SOURCE BEFORE SERVICING OR CLEANING.

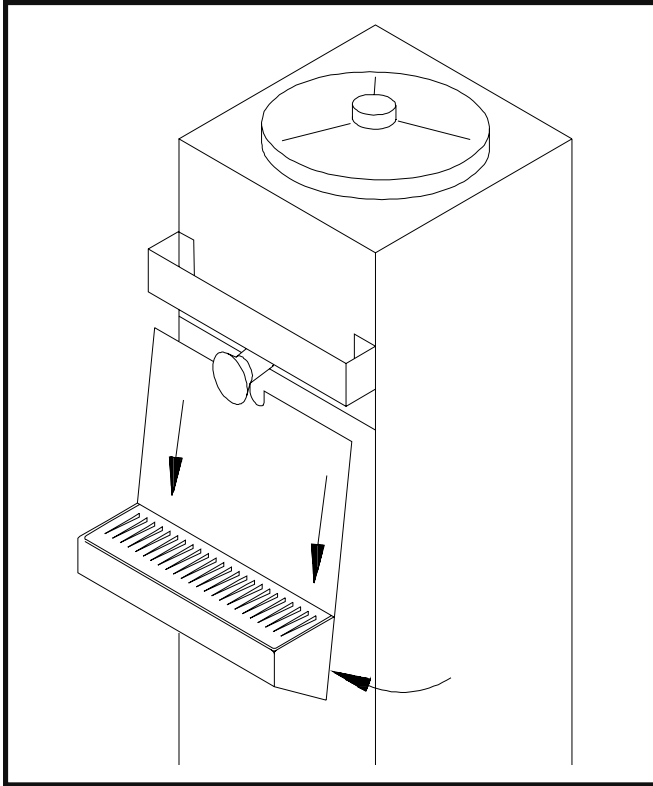

Figure 13
Removing Sani-tray and Cover

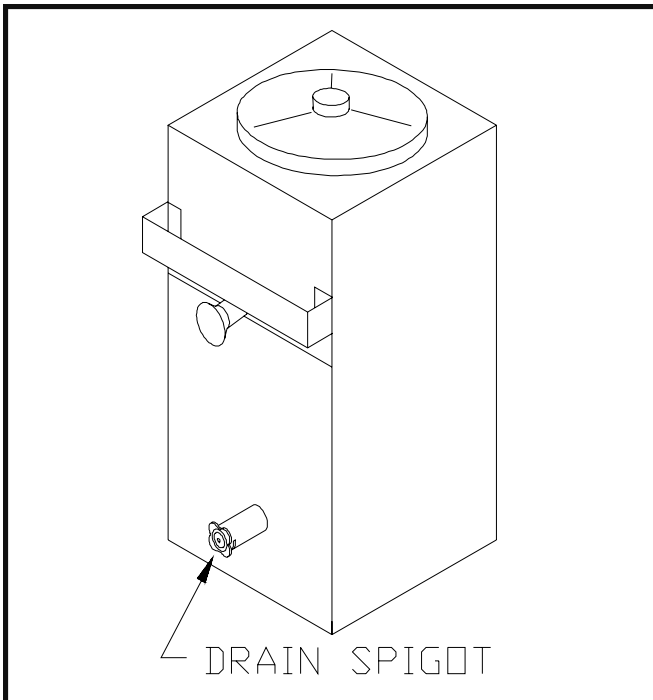

Figure 14
Draining Product

Inspection for worn or broken parts should be made during every disassembly of the freezer for cleaning or other purposes. All worn or broken parts should be replaced to ensure safety to both the operator and the customer, and to maintain good freezer performance as well as a quality product.

NOTE

Frequency of cleaning **MUST** comply with local health regulations.

The exterior of the freezer must be kept clean at all times to preserve the luster of the stainless steel. A mild alkaline cleanser is recommended. Use a soft cloth or sponge to apply the cleanser.

NOTE

Do not use acid cleaners, strong caustic compounds or abrasive materials to clean any plastic or stainless steel parts of the freezer exterior.

- A. Remove the dispensers from the side of the freezer by pulling straight up. Clean the cup dispensers and dispenser lids with a mild alkaline cleanser and soft cloth or sponge.
- B. Remove the sani-tray and insert by gently pushing up to disengage from the support pins and pulling out and down. Clean the sani-tray in the same manner as the cup dispensers.
- C. Remove the two-piece cover and mix level probe assembly and clean.
- D. Remove the flavor pumps from the bottles and pump warm soapy water through them. Then clean the bottles and pumps normally.
- E. To remove the upper and lower spigot assemblies, remove the retaining clip and pull the spigot assemblies straight out of the product outlet (Fig.15).

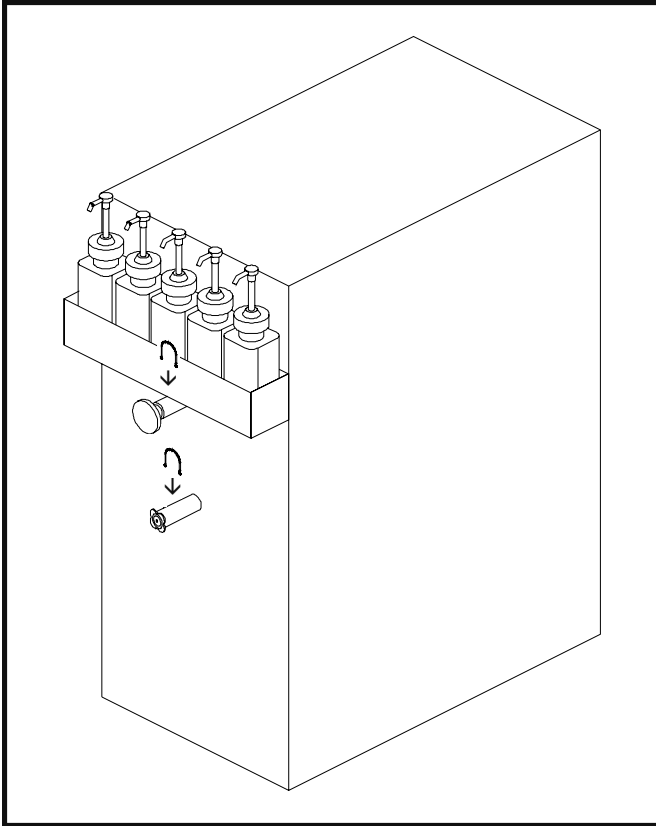

Figure 15
Removing Spigot Assembly

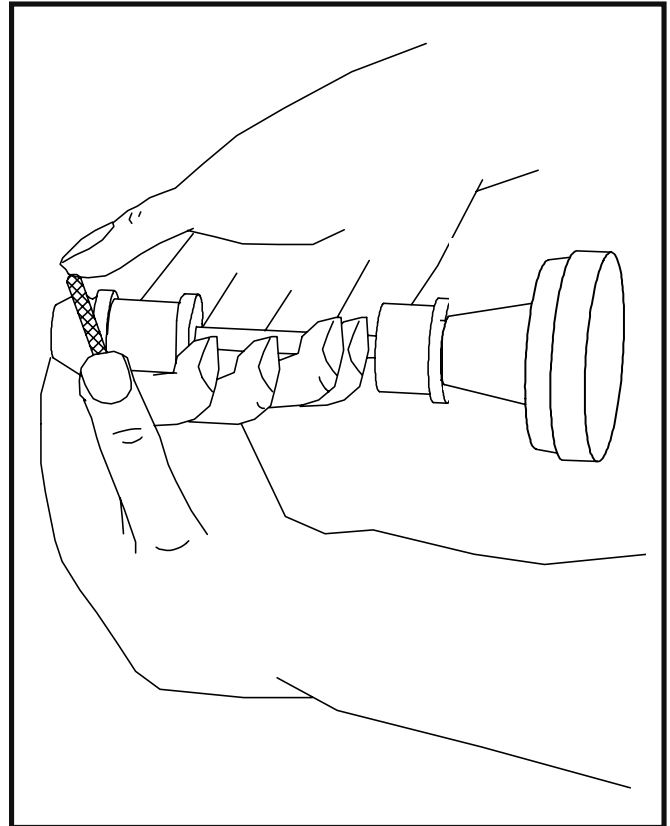

Figure 16
Removing Spigot O-Ring from Spigot body

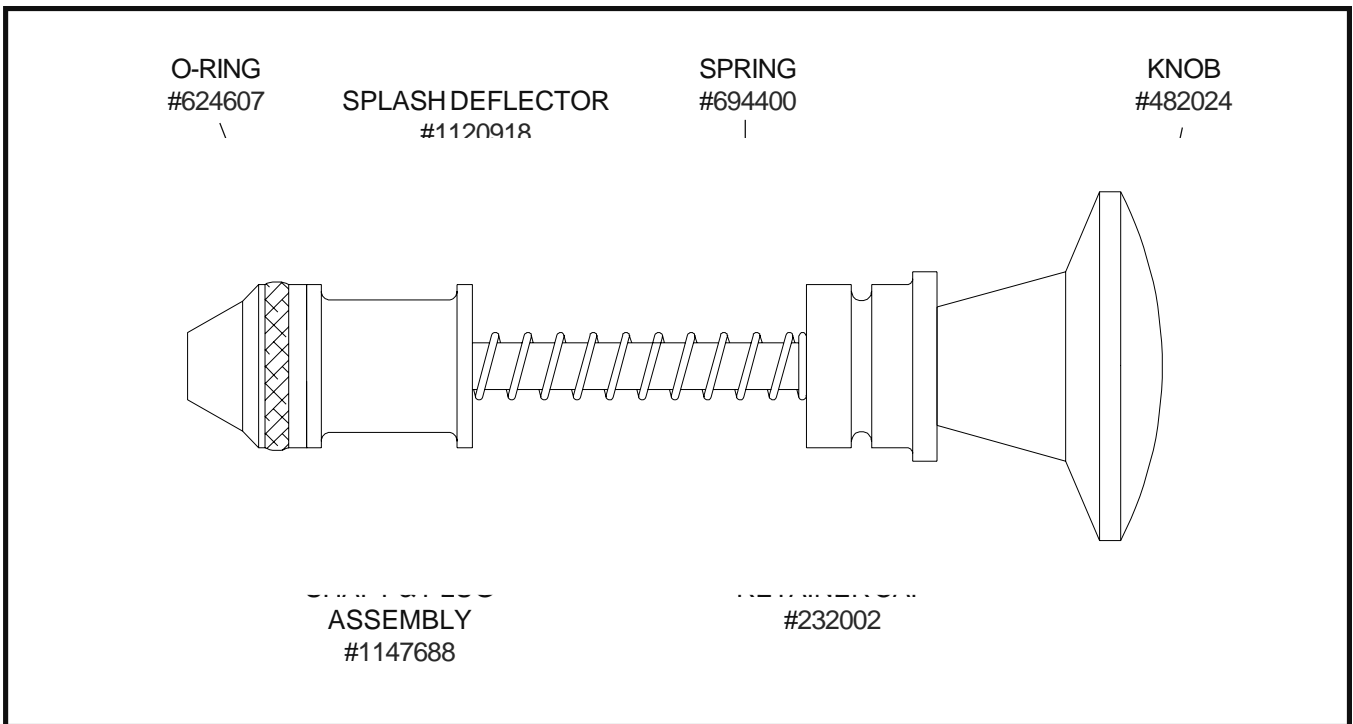

Figure 17
Cut-away View of Spigot Assembly

1. With a clean, dry towel, wipe excess lubricant from the spigot assembly and O-ring. Firmly grasp the spigot assembly with both hands and squeeze the O-ring upward (Fig 16). When a loop is formed, roll the O-ring out of the groove toward the end of the spigot assembly. (See Fig. 17 for a cutaway view of the spigot assembly.)

CAUTION

DO NOT USE ANY TYPE OF SHARP OBJECT TO REMOVE ANY O-RINGS.

2. Place all loose parts in a pan or container and take them to the wash sink, filled with warm, soapy water, for cleaning.
 3. Wash the product outlet with warm soapy water using the brush provided.
- G. For removal and disassembly of the divider plate and agitator assembly, refer to the following steps:

WARNING

PLACE THE ON-OFF-STIR ONLY SWITCH IN THE OFF POSITION AND DISCONNECT THE FREEZER FROM ELECTRICAL SUPPLY SOURCE.

1. Remove the drive cap and O-ring from the agitator tube (Fig.18).

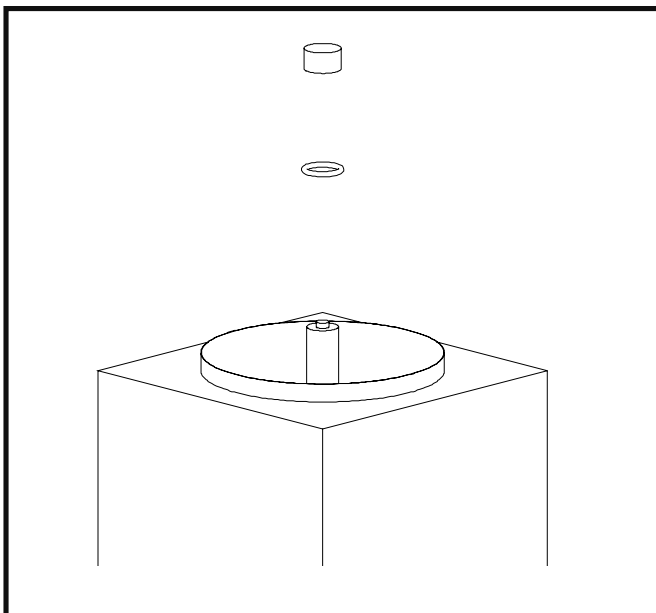

Figure 18
Removing Drive Cap and O-Ring

2. Remove the sealer ring by squeezing the looped section and lifting out of the product cylinder (Fig. 19).

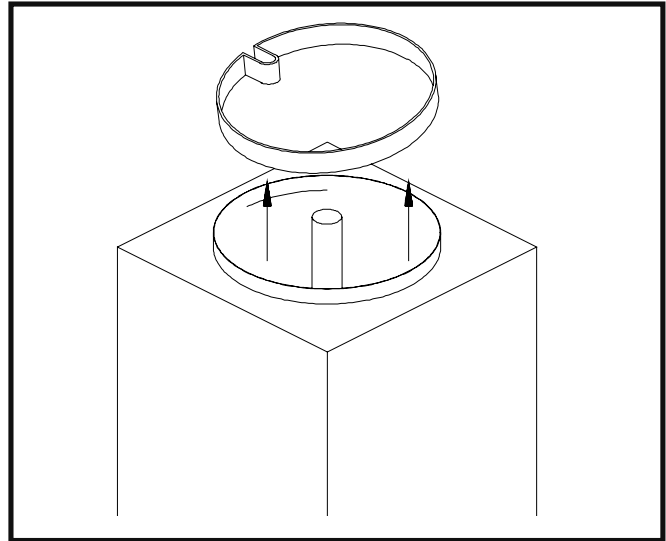

Figure 19
Removing Sealer Ring

3. To remove the divider plate and agitator assembly, the divider plate must be first rotated counterclockwise to unlock and lift out of the product cylinder.
4. Once the divider plate and agitator assembly are lifted off the vertical product cylinder center post and out of the product cylinder, remove the divider plate assembly and anti-lift disc. Remove the plastic agitator bushing from the bottom of the product cylinder center post by lifting up and out of the product cylinder (Fig. 20). - Refer to Figure 23 for an exploded view.

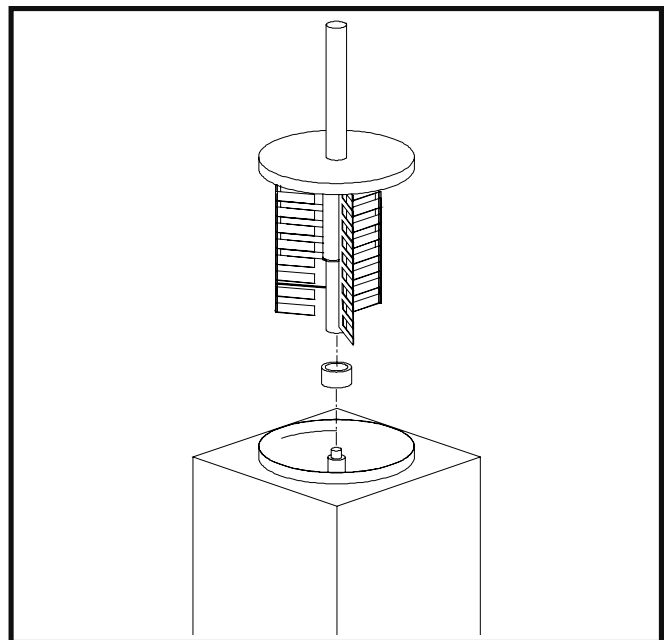

Figure 20
Removing Agitator Assembly and Lower Bushing

5. Unscrew the divider plate from the agitator fingers and remove (Fig.21).

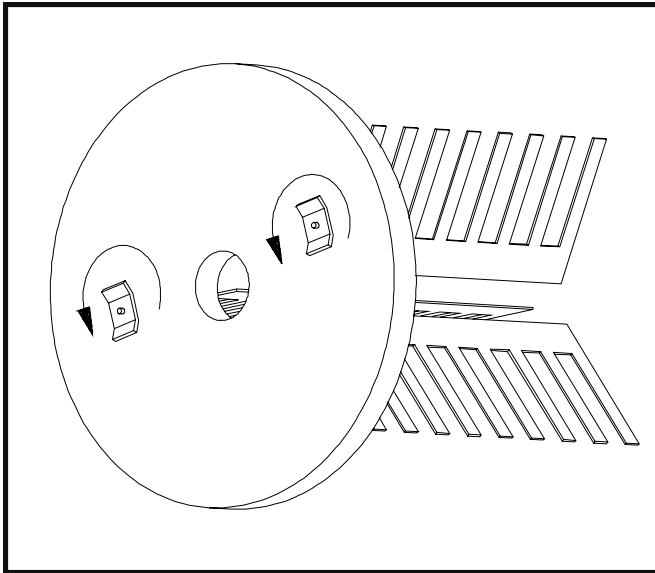

Figure 21
Removing Divider Plate from Agitator Fingers

6. Remove the drive shaft by pulling straight up and out of the vertical center post (Fig.22).

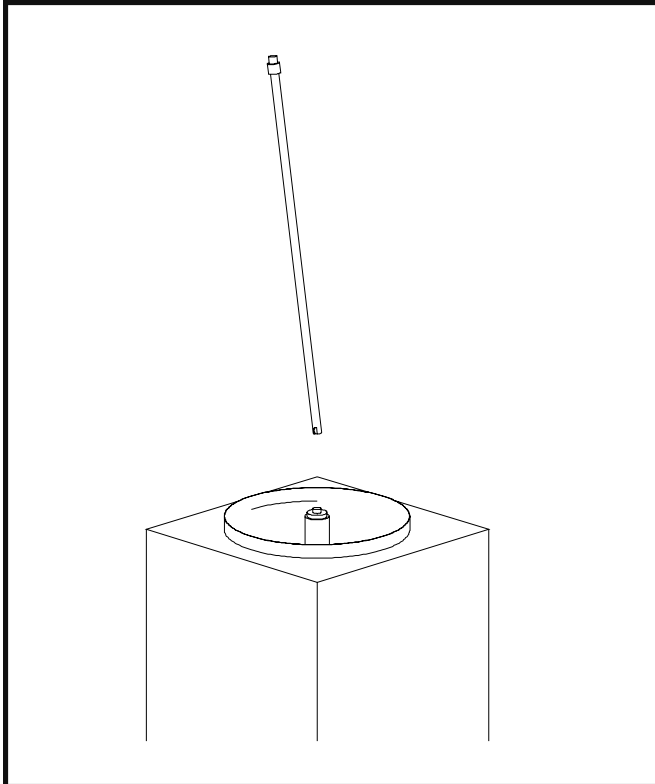

Figure 22
Removing Drive Shaft

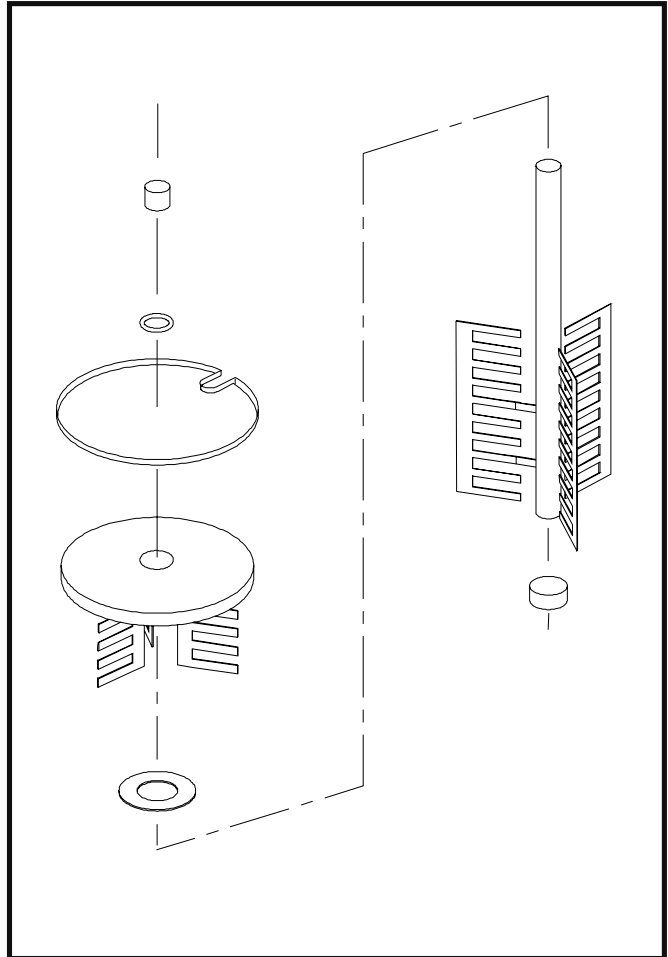

Figure 23
Exploded View of Divider Plate and Agitator Assembly

7. Place all loose parts in a pan or container and take them to the wash sink, filled with warm, soapy water, for cleaning.

CAUTION
DO NOT DAMAGE PARTS BY DROPPING OR ROUGH HANDLING.

NOTE
Do not attempt to wash the inside of the vertical product cylinder center post.

8. Wash the inside of the product cylinder with warm, soapy water, using the brush provided.

3.5 SANITIZING THE FREEZER AND FREEZER PARTS

After the freezer parts have been soaked and washed in warm, soapy water, they should be rinsed thoroughly in clean water.

All parts must be sanitized before assembling with a USDA certified food grade sanitizing solution (50 parts per million of free available chlorine or equivalent is acceptable).

- A. Mix a sanitizing solution of 50 parts per million to sanitize all loose parts before assembling.
- B. Place all loose parts in this solution, then remove and let air dry.
- C. Using this sanitizing solution and the brushes provided, sanitize the product cylinder and product outlet by dipping the brush in the sanitizing solution and scrubbing these areas.
- D. After assembling the freezer (Section 3.6), mix approximately 3 gallons (11.3 liters) of sanitizing solution and pour into the product cylinder. Brush the walls of the cylinder above the divider plate, with brushes provided to sanitize this reservoir area.
- E. Set the STIRRING ONLY-OFF-STIRRING & FREEZING switch in the STIRRING ONLY position and allow to stir for five minutes. Drain the solution in the same manner as draining the product.
- F. Pour approximately one pint (1/2 liter) of mixed neutral base into the product cylinder. Wait one minute, then drain the neutral base and remaining sanitizing solution through the drain spigot.

Sanitizing must be done after the freezer is clean and just before the product cylinder is filled with mixed neutral base. Sanitizing the night before is not effective. However, you should always clean the freezer and parts after use.

WARNING

THE UNITED STATES DEPARTMENT OF AGRICULTURE AND THE FOOD AND DRUG ADMINISTRATION REQUIRE THAT ALL CLEANING AND SANITIZING SOLUTIONS USED WITH FOOD PROCESSING EQUIPMENT BE CERTIFIED FOR THIS USE.

When sanitizing the freezer, refer to local sanitary regulations for applicable codes and recommended disinfecting products and procedures. The frequency of sanitizing must comply with local health regulations.

CAUTION

PROLONGED CONTACT OF SANITIZING SOLUTION WITH FREEZER MAY CAUSE CORROSION OF STAINLESS STEEL PARTS.

3.6 ASSEMBLY OF FREEZER

To assemble the freezer and freezer parts, refer to the following steps:

NOTE

Petro-Gel sanitary lubricant or equivalent must be used when lubrication of parts is specified.

The United States Department of Agriculture and the Food and Drug Administration require that lubricants used on food processing equipment be certified for this use. Use lubricants only in accordance with manufacturers instructions.

- A. Assemble the divider plate and agitator assembly as follows:
 - 1. Before installing the drive shaft, lubricate the bottom with Petro-Gel or any other type of sanitary lubricant. Enough lubricant must be applied to create approximately a 1/8 inch bulge at the bottom of the drive shaft (Fig.24).

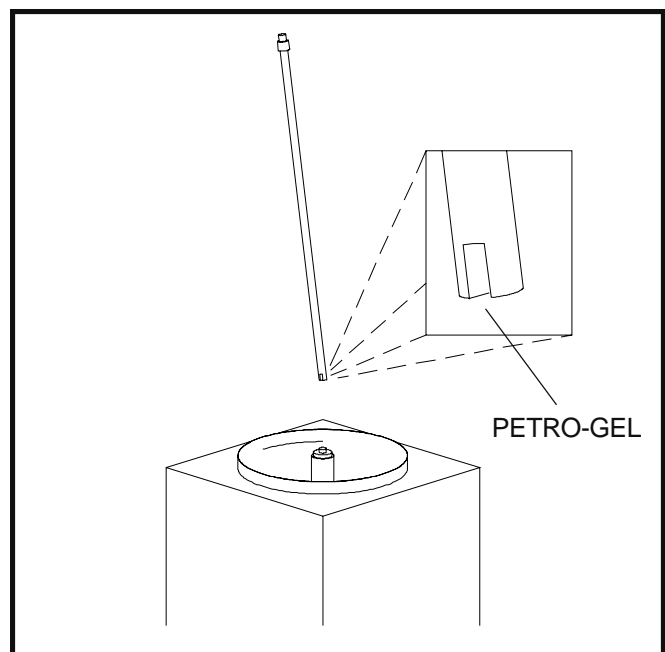

Figure 24. Lubricating Drive Shaft

2. Install the drive shaft into the center post by rotating and pressing down lightly on the shaft until the shaft drops down and engages with the gear box shaft.
3. Replace the plastic lower bushing to the bottom of the vertical center post.
4. Assemble the divider plate to the stationary fingers.
5. Assemble the anti-lift disc onto the agitator (See Fig.23).
6. Slide the divider plate down from the top of the agitator tube, until it is seated properly, allowing the agitator fingers clearance for rotation.
7. Assemble the divider plate and agitator assembly onto the vertical center post, making sure the indicator arrow on the divider plate is in position to line up with the upper spigot. Grasp the agitator tube and slide the assembly down the vertical center post and lock (Fig. 25).

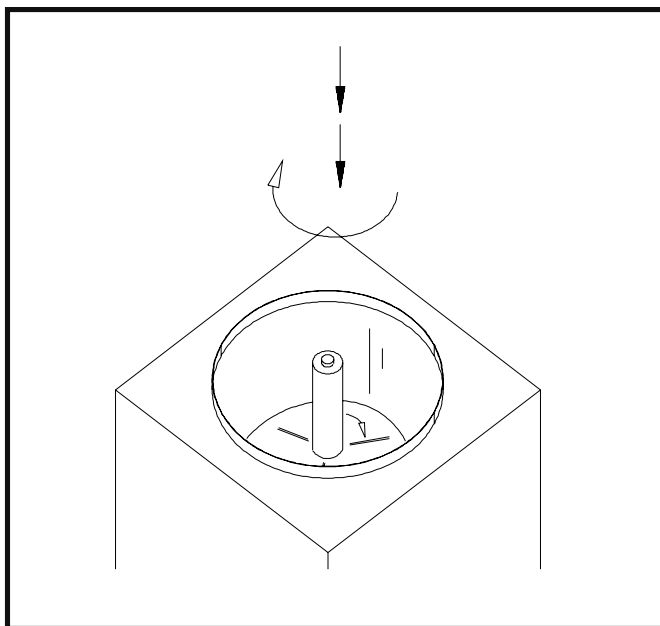

Figure 25
Installing Divider Plate and Agitator Assembly

8. Install the sealer ring by squeezing the looped section and sliding down into the product cylinder.

NOTE

For proper operation of the freezer, the looped section of the sealer ring MUST be positioned to the back of the product cylinder (Fig.26).

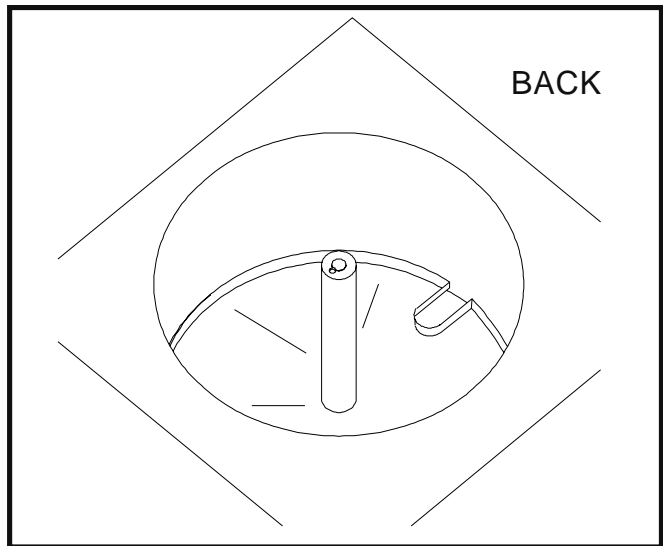

Figure 26
Proper Installation of Sealer Ring

9. Roll the agitator tube "O"-Ring completely down the agitator tube until it seals tightly to the divider plate.
10. Rotate the agitator tube clockwise until the guide hole at the top of the agitator tube forms a complete circle with the hole at the top of the vertical center post (Fig.27).

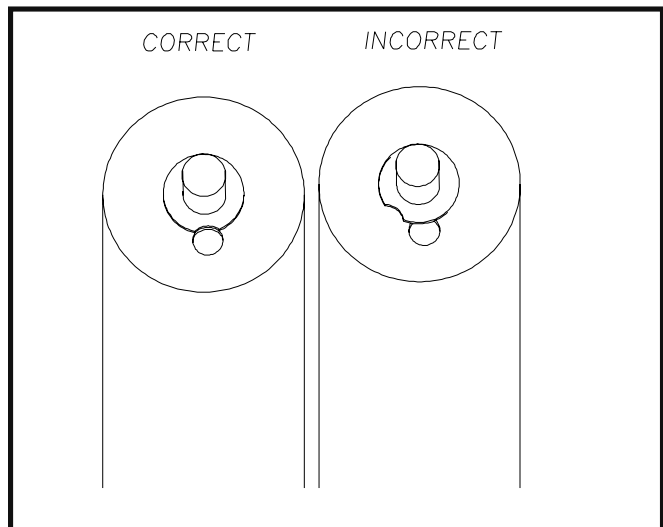

Figure 27
Correct and Incorrect Alignment of Vertical Center Post Guide Hole

11. Assemble the drive cap onto the agitator tube, aligning the guide pin in the drive cap with the guide hole in the vertical center post and pressing down.

B. Assemble O-rings onto the spigot plungers **without lubricant**. Then apply a thin film of sanitary lubricant to the exposed surfaces of the O-rings.

1. Insert the spigot assembly into the product outlet.
2. Slide the spigot retaining clip into position.

C. Assemble the flavor bottles as follows:

1. Replace the bottles in the flavor rack.

D. Install sani-tray and cover.

E. Replace the cup dispensers on the side of the freezer by positioning the bracket on the dispenser above the bracket on the side of the freezer and sliding down.

3.7 MIX INFORMATION

It is essential to follow the mixing instructions on the neutral base container carefully. The concentration of ingredients in the product, which determines the "Brix" (sugar level), is very important to the operation of the freezer and the quality of the drink. When the proper amount of neutral base is mixed with the proper amount of water, the mixture should have a "Brix" reading between 11 and 13.

CAUTION

DO NOT POUR THE INDIVIDUAL INGREDIENTS (WATER OR NEUTRAL BASE) DIRECTLY INTO THE FREEZER AND DEPEND ON THE AGITATOR TO DO THE MIXING. THIS DOES NOT PROVIDE FOR ADEQUATE MIXING AND MAY CAUSE DAMAGE TO THE FREEZER.

Refer to the following steps for filling the freezer:

- A. Follow instructions on the Slush Puppie neutral base containers to mix neutral base with water. Then pour into the freezer.
- B. The product cylinder has a 10 gallon capacity, when filled approximately 1" (2.54 cm) from the top of the cylinder. When filling the cylinder, it is necessary to remove all trapped air from below the divider plate.

Fill the product cylinder with mix to within 1" (2.54 cm) from the top. Place a sanitary container under the serving spigot and dispense small amounts of liquid by pulling out and pushing in the spigot in a series of short bursts. Each time the spigot is closed, bubbles will rise to the top of the liquid in the product cylinder. When no more bubbles rise to the top, the air trapped under the

divider plate has been removed. Pour the contents of the container back into the product cylinder.

3.8 FREEZE DOWN AND OPERATION

- A. With mixed Slush Puppie neutral base in the product cylinder, start the freezing process by setting the STIRRING ONLY-OFF-STIRRING & FREEZING switch in the STIRRING & FREEZING position.
- B. Although servable product can be obtained after the freezer has been run for 1 hour, the best quality ice crystals will develop after the freezer has been running for several more hours.

3.9 DISPENSING PRODUCT

To dispense product correctly, refer to the following steps:

- A. Select the desired cup size.
- B. Dispense flavor concentrate into the cup first, by pushing the flavor pump down. Use one squirt of flavor for small cups, two squirts for medium cups and three squirts for large cups.
- C. Place cup under and against the spigot.
- D. Pull the spigot out.
- E. Fill the cup. The gravity flow from the spigot will automatically mix the flavor concentrate with the neutral base mixture as it is dispensed.
- F. When the cup is full, push the spigot in.

3.10 ROUTINE CLEANING

To remove spilled or dried mix from the freezer exterior, simply wash in the direction of the finish with warm soapy water or a mild alkaline cleanser and a soft cloth or sponge. Do not use abrasive materials as they will mar the finish of the freezer.

Refer to Figure 28 for all external parts of the freezer to be cleaned.

3.11 PREVENTATIVE MAINTENANCE

It is recommended that the following maintenance schedule be followed to keep the freezer clean and operating properly.

CAUTION

NEVER ATTEMPT TO REPAIR OR PERFORM MAINTENANCE ON THE FREEZER UNTIL THE MAIN ELECTRICAL POWER HAS BEEN DISCONNECTED.

A. DAILY

1. The exterior should be kept clean at all times to preserve the lustre of the stainless steel. A mild alkaline cleanser is recommended. Use a soft cloth or sponge to apply the cleanser.

CAUTION

DO NOT USE ACID CLEANERS, STRONG CAUSTIC COMPOUNDS OR ABRASIVE MATERIALS TO CLEAN ANY PART OF THE FREEZER EXTERIOR OR PLASTIC PARTS.

2. Clean the sani-tray by lifting up, out, and rinsing and replacing.

B. WEEKLY

1. Remove the sani-tray and cover. Clean behind the drip tray with a soap solution.
2. Check all "O" Rings for excessive wear and replace if necessary.

C. MONTHLY

CAUTION

THE FREEZER HAS AN AIR COOLED CONDENSER AND MUST HAVE PROPER AIR CIRCULATION.

DO NOT PLACE THE E257 FLOOR MODEL FREEZER ANY CLOSER THAN SIX (6) INCHES (15.2 CM) FROM THE WALL.

THE COUNTER MODEL FREEZER REQUIRES A 3" (7.6 CM) CLEARANCE ON THE SIDES, A 1" (2.5 CM) CLEARANCE AT THE REAR, AND A 10" (25.4 CM) CLEARANCE AT THE TOP.

FAILURE TO CLEAN THE CONDENSER FILTER MAY RESULT IN SERIOUS FREEZER DAMAGE AND COULD VOID THE WARRANTY.

CONDENSER CLEANING

1. For the floor models, remove the sani-tray and insert. Remove the two phillips head screws from the lower front panel and pull panel down and out. Blow the dirt out from the opposite side of the condenser using an air tank, CO₂ tank, or vacuum.
2. For the counter model, remove the six phillips head screws from the back panel. Then clean the condenser using the same method as on the floor model.

3.12 EXTENDED STORAGE

Refer to the following steps for storage of the freezer over any long period of time:

- A. Place the STIRRING ONLY-OFF-STIRRING & FREEZING switch in the OFF position.
- B. Disconnect (unplug) the freezer from the electrical supply source.
- C. With a warm detergent solution, thoroughly clean all parts that come in contact with neutral base mix or flavors. Rinse in clear water and dry all parts. Do not sanitize.

NOTE

Do not let cleaning solution or products stand in the product cylinder during shutdown period.

- D. Remove, disassemble and clean the spigot assemblies and lower bushing. Place these parts in a plastic bag with a moist paper towel to prevent them from becoming brittle.

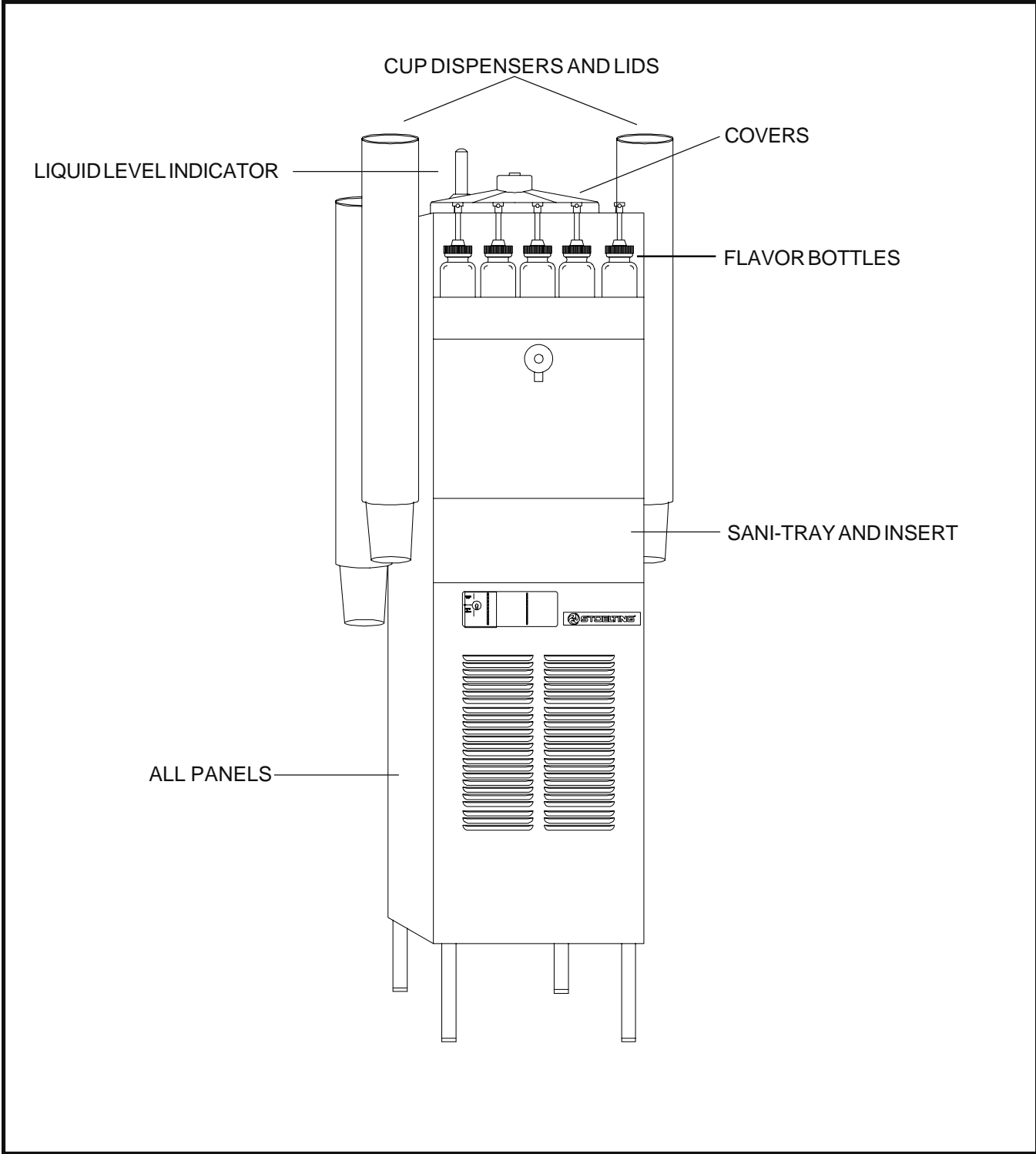

Figure 28
External Parts To Be Cleaned

**SECTION 4
DECALS AND TAGS**

4.1 HOW TO ORDER DECALS AND TAGS

To assure receipt of the proper warning decals, supply your dealer or distributor with the following information:

- A. Model number of equipment.
- B. Serial number of model, stamped on nameplate.
- C. Part number, decal description and quantity needed. Common warning decal names and numbers are listed below.

DECALS AND TAGS FOR MODELS 100C, 100F & 2217G	
PART NUMBER	DESCRIPTION
324105	DECAL CAUTION: ELECTRIC SHOCK
324107	DECAL CAUTION: MOVING PARTS
324113	DECAL CAUTION: GROUNDED PLUG
324135	DECAL TOGGLE & SAFETY SWITCH
324200	DECAL MANUAL RESET
324393	DECAL STOELTING SWIRL
324548	DECAL ADEQUATE VENTILATION - 100F Floor Model
324585	DECAL REFRIGERATION CHARGE
324649	DECAL ADEQUATE VENTILATION - 100C - Counter Model
723516	TAG ATTN: SET TIMER
723526	TAG READ MANUAL
723529	TAG CAUTION
723537	TAG SANITARY CLEAN

SECTION 5 REFRIGERANT COMPONENTS AND ADJUSTMENTS

5.1 REFRIGERATION SYSTEM

This section is intended to provide qualified refrigeration technicians with a general understanding of the refrigeration system, its components and adjustments. It is recommended that any work done on the freezer be performed by a qualified refrigeration technician.

5.2 COMPRESSOR

A. Winding Test

To test the compressor motor windings for possible problems, perform the following steps:

WARNING

DISCONNECT FREEZER FROM ELECTRICAL SUPPLY BEFORE SERVICING.

1. Remove the two Philips head screws from the bottom of the back panel and slide the side panel down, back and out.
2. Remove the compressor terminal cover by inserting a standard screwdriver under the terminal cover and retaining frame, pry out side then hold with your hand while prying the other side. (Figure 30)

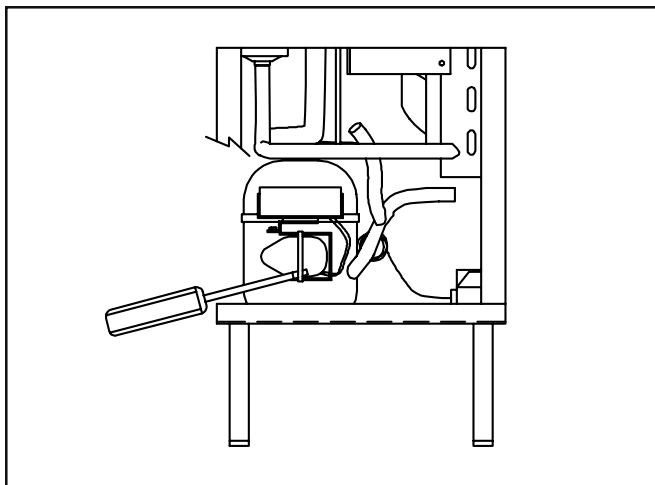

Figure 30. Removing Compressor Terminal Cover

3. Remove retaining clip and cover.
4. Remove the three wires from the compressor terminals.
5. Set your ohmmeter at X1 and connect the ohmmeter to terminals C and R to check resistance through run windings. Refer to Figure 31 for compressor terminals.
6. Set your ohmmeter at X1 and connect the ohmmeter to terminals C and S to check resistance through the start windings.

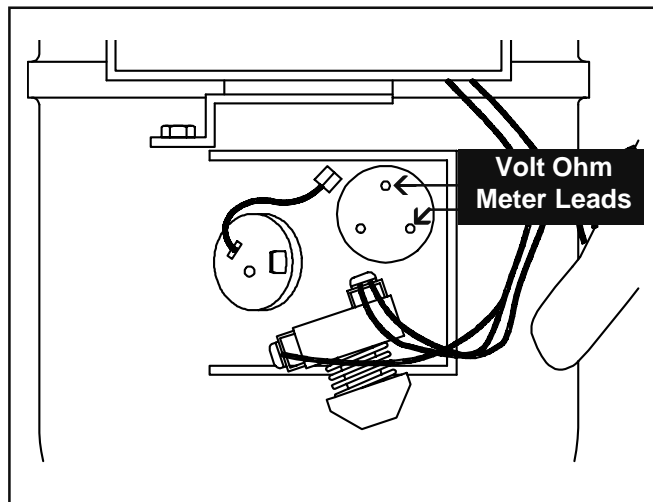

Figure 31. Check Windings

NOTE

Check your compressor handbook for proper values. (Available from compressor manufacturer.)

7. To check if windings are shorted to ground, connect one ohmmeter lead to a bare metal part on the compressor and check terminals C, R, and S. (Fig. 32)

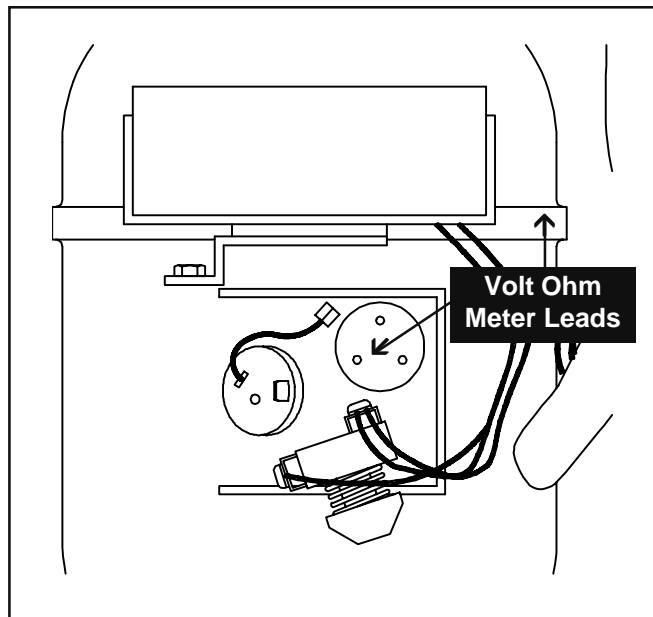

Figure 32. Check Winding to Ground

5.3 CONDENSER

The condenser is a air-cooled copper tube and aluminum fin type. Condensing is totally dependent upon air flow. A plugged condenser or restrictions in the louvered side panel will restrict air flow.

CAUTION
AIR RESTRICTIONS WILL LOWER THE CAPACITY OF THE SYSTEM AND DAMAGE THE COMPRESSOR.

The condenser must be kept free of dirt and grease. The freezer **MUST** have a minimum of 6" (15.2 cm) of ventilation at all louvered panels for free flow of air. Make sure the freezer is not pulling over 100°F (37°C) air from other equipment in the area.

NOTE

Slush Freezers can not operate at temperatures over 120°F ambient.

The optional condenser filter and condenser require periodic cleaning. To clean, refer to the following procedures:

1. Remove the condenser filter from the lower front panel and visually inspect for dirt. If the filter is dirty, shake or brush excess dirt off the filter and wash in warm soapy water. Once the filter is clean, rinse thoroughly in warm, clean water and shake excess water out taking care not to damage the filter in any way. Install the filter back onto the front panel.
2. For Model 100F, remove the sani-tray and insert. Remove the two phillips head screws from the lower front panel and pull panel down and out.
3. Visually inspect the condenser for dirt by shining a light through the coil from the back of the condenser (Fig. 33.)

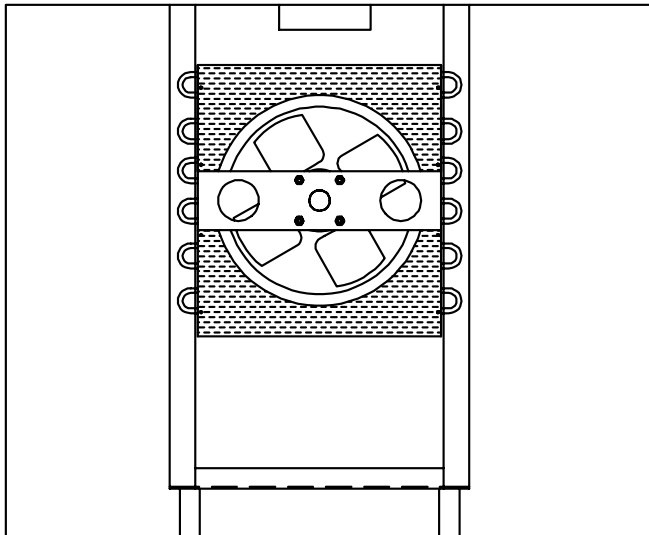

Figure 33. Check Condenser

4. If the condenser is dirty, place a damp towel over the condenser.
5. Using compressed air or CO₂ tank, blow out the dirt from the back of the condenser. Most of the dirt will cling to the wet towel.

6. An alternative method of cleaning the condenser is to use a condenser brush and vacuum.

NOTE

If the condenser is not kept clean, loss of refrigeration efficiency will result, causing extended run time or inadequate product consistency.

7. For the Model 100C, remove the phillips head screws from the back panel and remove the panel. Clean the condenser following steps 4 - 6 above.

PRODUCT CYLINDER (EVAPORATOR)

An automatic expansion valve (A.X.V.) is used to control the refrigerant flow to the freezing area of the product cylinder. The adjustable A.X.V. is preset at the factory. If the product is too thick or too thin, an A.X.V. adjustment may be necessary.

A. A.X.V. Adjustment

To adjust the A.X.V., refer to the following procedures:

1. Remove the two philips head screws from the back side panel and pull panel down and out (Model 100F). Remove the left side and back panel (Model 100C).
2. Remove the cap from the Schrader valve on the compressor (Fig. 34).

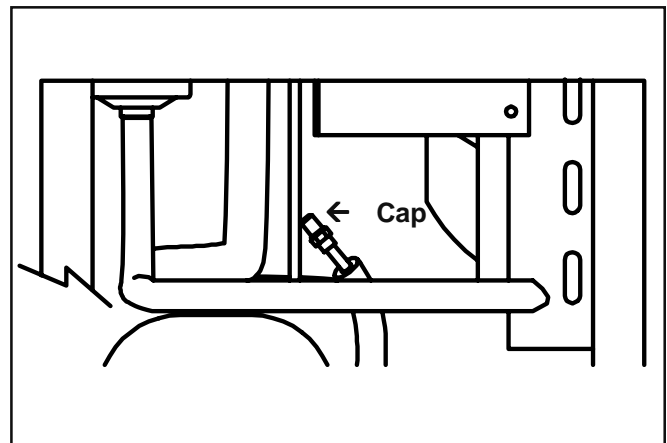

Figure 34. Remove Cap

3. Install a 0-100 P.S.I.G. gauge onto the Schrader valve (Fig. 35).
4. Start the refrigeration cycle and read the pressure

NOTE

Freezer must be full of product and past initial freeze down.

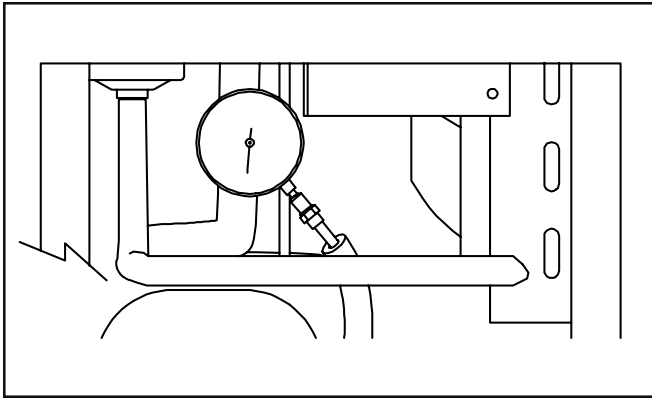

Figure 35. Install Gauge

5. Pressure gauge reading should be:

Model	100C	100F	100C	100F	2217	2217G
Refrig.	R12	R12	R22	R22	R502	R404A
Head Pressure	110	110	160	160	170	190
Suction Pressure	See Chart Below	See Chart Below	33	33	28	42

6. If the pressure gauge reading does not fall within those specifications, proceed with the following steps:

7. Remove the cap the the A.X.V. and, using a small wrench, turn the adjusting screw 1/4 turn (90°) counter-clockwise for more cooling or 1/4 turn (90°) clockwise for less cooling (Fig. 36.)

8. Allow the system to level out for three to five minutes before taking another pressure reading.

9. Should the reading still not fall within specifications, repeat steps 8 and 9 until the correct reading is obtained.

10. Once the correct reading is obtained, replace the cap. Remove the pressure gauge from the Schrader valve and replace the Schrader valve cap.

11. Replace the rear panel.

B. A.X.V. Removal

CAUTION

IF IT IS NECESSARY TO REPLACE THE A.X.V., A HEAT SINK (WET CLOTH) MUST BE USED TO PREVENT DAMAGE TO THE VALVE.

1. Assuming the side and rear panels have been removed, perform the following procedures for removing the A.X.V.

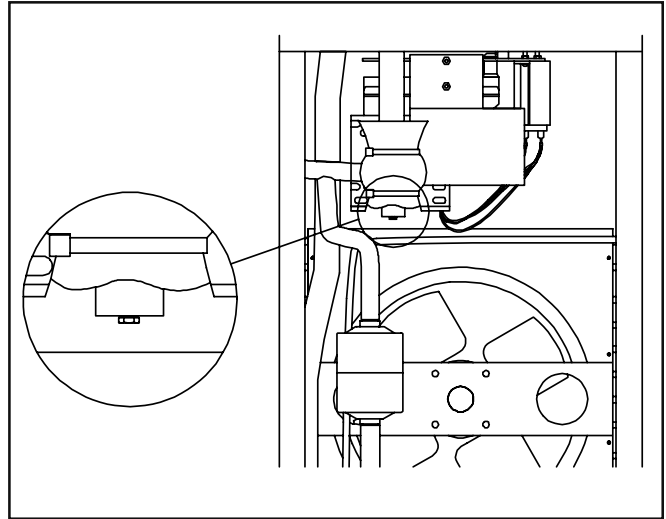

Figure 36. Adjust A.X.V.

WARNING

DISCONNECT FREEZER FROM ELECTRICAL SUPPLY SOURCE BEFORE SERVICING.

2. Recover the refrigerant charge, then leave a port open to prevent pressure build-up during A.X.V. removal.

3. Remove foam insulation from surrounding lines.

4. Apply a heat sink (wet cloth) to the A.X.V.

5. Unsweat the A.X.V. from its connecting lines.

6. Remove the A.X.V. with the heat sink.

C. T.X.V. Replacement

To replace the A.X.V., perform the following procedures:

CAUTION

WHEN REPLACING THE A.X.V., A HEAT SINK (WET CLOTH) MUST BE USED TO PREVENT DAMAGE TO THE VALVE.

1. Position the A.X.V. with heat sink, so the refrigeration line correspond with the proper valve ports.

2. Braze lines to the A.X.V. using the appropriate brazing material.

3. Remove the heat sink from the A.X.V.

4. Replace any foam insulation to the surrounding lines.

5. Once the A.X.V. is installed, the refrigeration system must be purged and evacuated to 50 microns of mercury for approximately 30 minutes.

6. Break the vacuum to (0 P.S.I.G.) with dry nitrogen, then with an open port, replace the filter drier using the appropriate brazing material. (Fig.37).
7. Once the filter drier has been replaced, repeat the evacuation and recharging procedures.

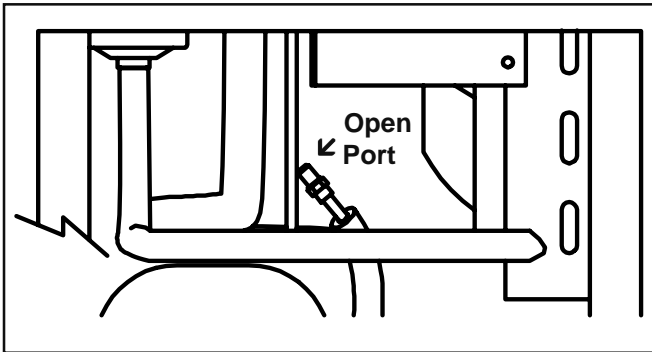

Figure 37. Filter Drier Replacement

SECTION 6 ELECTRICAL SYSTEM OPERATION AND ADJUSTMENTS

6.1 24 HOUR TIMER

The 24 hr. timer is used to eliminate refrigeration during non-use hours. When properly set it will prevent build-up of large ice crystals and/or build-up of ice on the agitator. The timer is located behind the lower front panel. To program the timer, rotate program disc in the direction of the arrows to align the correct time with the time of day. Then pull out for OFF time or push in for ON time. Each actuator is equivalent to 15 minutes. Check for AM/PM centered between 12 and 12 on rotating disc. At a 6:00 setting, the indicator will point to AM or PM.

6.2 ELECTRONIC TORQUE CONTROL

The electronic torque control is a time delay that controls the operation of the compressor. The electronic torque control operates in unison with two micro switches (ON and OFF) and the agitator drive motor. If the control is viewed from the back of the freezer while the freezer is operating, the following conditions of normal operation will be evident:

WARNING

VIEWING THE FREEZER WITH ANY SIDE PANEL REMOVED DURING OPERATION IS NOT RECOMMENDED, AS THE POSSIBILITY OF ELECTRICAL SHOCK HAZARD IS GREATLY INCREASED. THIS PROCEDURE HAS BEEN ADDED ONLY TO CLARIFY THE THEORY OF OPERATION.

1. When the right hand arm of the control bracket contacts the right hand micro switch, the compressor will start.
2. As the compressor continues to run, ice crystals are being formed in the product cylinder. As the drive motor torque increases due to the formation of ice crystals, the left-hand arm of the control bracket will gradually move to the right and contact the left-hand micro switch. The compressor will SHUT OFF approximately 71 to 81 seconds after the arm maintains contact with the micro switch. This prevents erratic freeze down and rapid recycling of the compressor.

See Figure 38 for a visual description of the components involved in this operation.

A. Consistency Adjustment

The tension spring (Fig.39), located on the right side of the freezer, is used to adjust the product consistency. To increase product consistency, increase the spring tension by turning the eyebolt nut clockwise one turn. To decrease product consistency, decrease the spring tension by turning the eyebolt nut counterclockwise one turn.

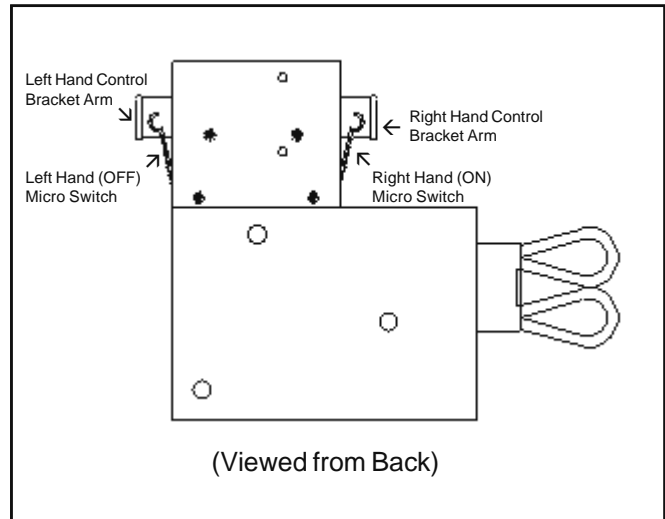

Figure 38. Torque Control

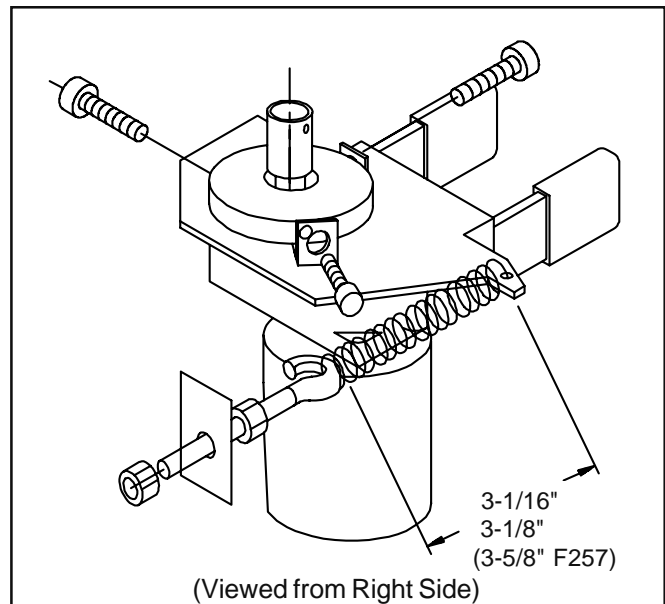

Figure 39. Tension Spring

NOTE

The tension spring is adjusted at the factory to 3-1/8 inches, (3-5/8 for the 2217G). If further adjustment is necessary, turn the eyebolt nut one turn at a time in the desired direction.

B. Micro Switch Removal

Should either the right or the left micro switch be found to be defective, either switch can be replaced by performing the following procedures:

WARNING

DISCONNECT FREEZER FROM ELECTRICAL SUPPLY SOURCE BEFORE SERVICING.

1. Remove the necessary panels. Model 100F back panel, Model 100C left side panel.
2. Using a 5/16" wrench, remove the two nuts and star washers from the torque control mounting bracket (Fig.40).

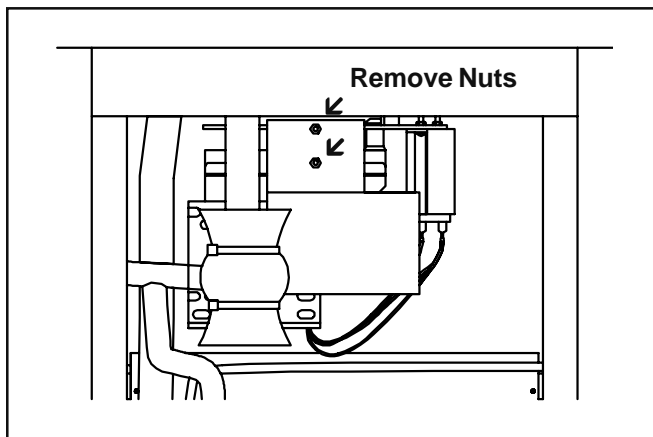

Figure 40. Removing Torque Control

3. Remove the torque control from the mounting bracket by pushing the assembly toward the left side of the freezer until the mounting studs are clear of the mounting bracket. Then pull the assembly down and towards you.
4. Using a 1/4" wrench, remove the two nuts from the rear of the defective micro switch.
5. Remove the micro switch from the mounting studs and disconnect from the connector.

C. Micro Switch Replacement

1. Connect a serviceable micro switch to connector.
2. Install micro switch onto the mounting studs and fasten with the two hex nuts. Tighten nuts snugly with 1/4" wrench. Do not over tighten.
3. Position torque control behind the mounting bracket and allow the two studs to be pushed through the holes in the mounting bracket.
4. Install the two star washers and nuts onto the mounting studs. Tighten nuts snugly with a 5/16" wrench. Do not over tighten.
5. Replace the back panel.

SECTION 7 MAJOR COMPONENT REMOVAL AND INSTALLATION

7.1 INTRODUCTION

This section covers the removal and installation of the condenser fan, drive motor and compressor. It is extremely important to follow each step accurately and completely. Failure to do so could result in further problems later.

7.2 CONDENSER FAN REMOVAL

To remove a condenser fan which has been found to be defective, refer to the following procedures:

WARNING
DISCONNECT FREEZER FROM ELECTRICAL
SUPPLY SOURCE BEFORE SERVICING.

1. Remove the necessary panels: Model 100F back and side panels, Model 100C back panel and back shroud.
2. Disconnect the condenser fan lead wires.
3. Using a 5/16" nut driver or a phillips screwdriver, remove the four fastening screws from the fan mounting brackets (Fig.41).

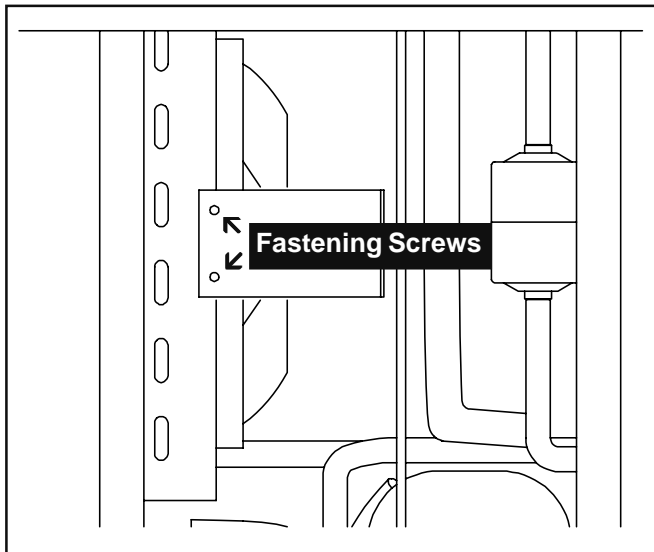

Figure 41. Fan Removal

4. Remove the fan and its supports through the side of the freezer taking care not to damage the fan blade.

7.3 DRIVE MOTOR REMOVAL

To remove a defective drive motor, perform the following procedures:

WARNING
DISCONNECT FREEZER FROM ELECTRICAL
SOURCE BEFORE SERVICING.

1. Remove the necessary panels. Model 100F back and side panels. Model 100C front sides and bottom panels.

2. Disconnect the lead wire from the drive motor capacitor.
3. Disconnect the wire leading from the drive motor to the reset switch on the front of the freezer (Fig.42),
4. Remove the three socket head cap screws securing the mounting flange to the bearing (Fig.43). Remove the drive motor from either side.

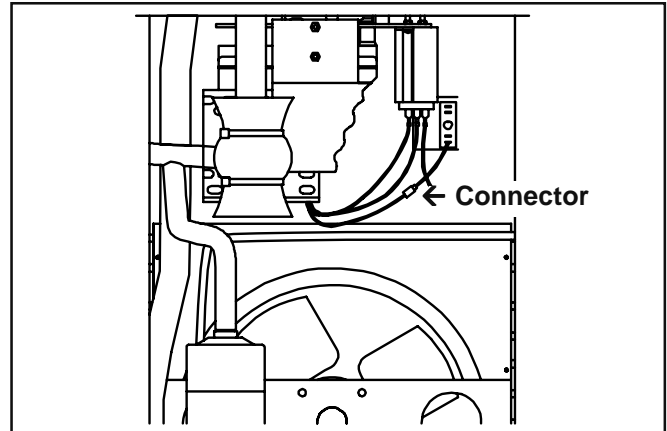

Figure 42. Disconnect Wire

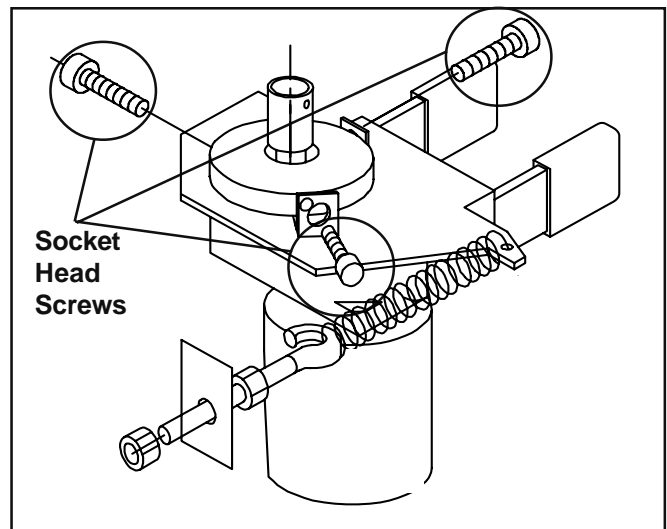

Figure 43. Drive Motor Removal

If the drive motor failure is due to a defective drive motor mount bearing, replace the bearing assembly as follows:

1. Remove snap ring.
2. Slide bearing down and off.
3. Slide new bearing on and replace snap ring. Bearing must turn freely when assembled.

7.4 COMPRESSOR REMOVAL

To remove a defective compressor, perform the following procedures:

WARNING
DISCONNECT FREEZER FROM ELECTRICAL SUPPLY SOURCE BEFORE SERVICING.

1. Remove the necessary panels. Model 100F back and side panels. Model 100C back panel and back shroud.
2. Disconnect lead wires at the compressor.
3. Recover refrigerant charge, then leave a port open to prevent pressure build-up during compressor removal.
4. Unsweat the suction line and discharge line from the compressor (Fig.44).

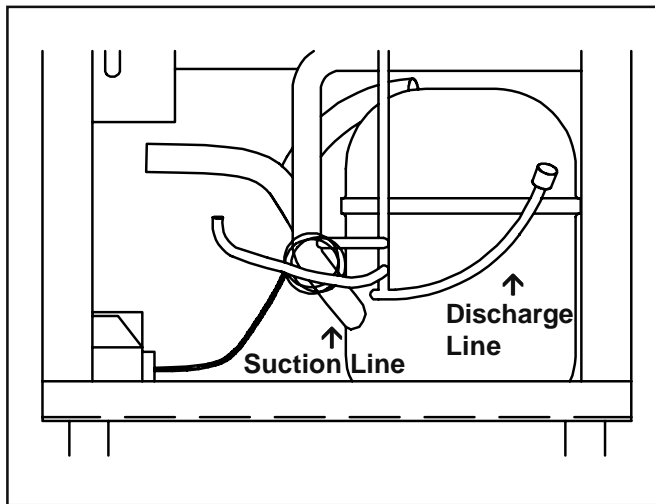

Figure 44. Compressor Removal

5. Remove the four nuts and four washers from the base of the compressor.
6. Remove compressor through left side of the freezer.
7. Remove the four rubber compressor mounts from the old compressor.

NOTE

Rubber mounts are not always furnished with replacement compressors.

8. Unsweat the access fitting line from the compressor.
9. Check the compressor for a burn-out condition using an acid test kit. **If acid is found, clean out the system per the compressor manufacturer's instructions.**
10. Sweat shut all open ports of the old compressor.

NOTE

A compressor returned to the company with any open ports will void the warranty. **ALWAYS** plug any open ports on a compressor that has been removed.

7.5 COMPRESSOR INSTALLATION

To install a serviceable compressor, perform the following procedures:

WARNING
DISCONNECT FREEZER FROM ELECTRICAL SUPPLY SOURCE BEFORE SERVICING.

ASSUMING THE SIDE AND BACK PANELS HAVE BEEN REMOVED FOR COMPRESSOR REMOVAL AND THE ENTIRE REFRIGERATION SYSTEM PURGED THOROUGHLY, YOU CAN BEGIN INSTALLING A NEW COMPRESSOR.

WARNING
IF ACID IS FOUND IN THE SYSTEM, CLEAN OUT PER COMPRESSOR MANUFACTURER'S INSTRUCTIONS.

1. Install the four rubber compressor mounts on the replacement compressor.
2. Remove all plugs from the replacement compressor.
3. Braze the access fitting line to the correct compressor port, using the appropriate brazing material.
4. Install the compressor into the freezer, from the left side, fitting the base over the four mounting studs.
5. Install the four washers and four nuts onto the mounting studs and tighten securely.
6. Leaving a port open to prevent pressure build-up, braze the suction line and discharge line to the compressor (Fig.45).

NOTE

Cap and valve must be removed.

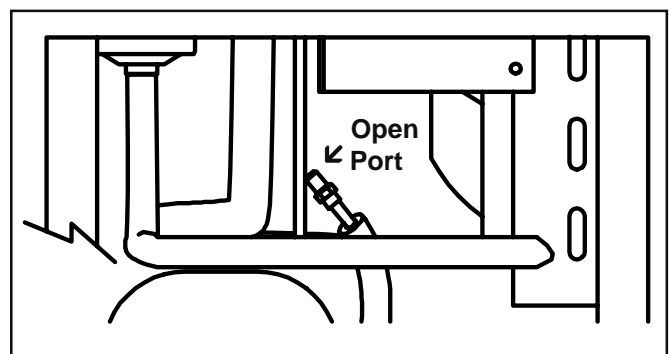

Figure 45. Install Compressor

7. Connect the lead wires to the compressor. Replace the terminal cover and retaining clip.
8. Evacuate the refrigeration system to 50 microns of mercury for approximately 30 minutes.

9. Break the vacuum (0 P.S.I.G.) through the Schrader valve with the dry nitrogen.
10. Leaving a port open to prevent pressure build-up, remove the filter drier and install a new filter drier using the appropriate brazing material (Fig.46).

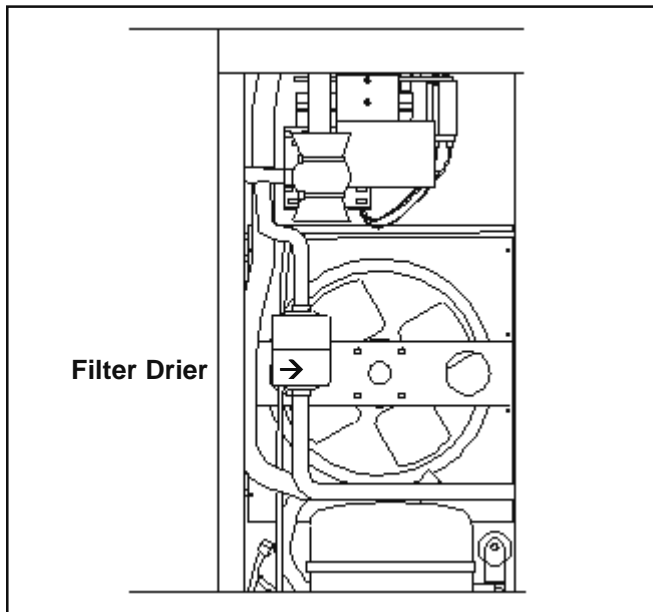

Figure 46. Remove Filter Drier

11. Purge and evacuate the refrigeration system to 50 microns of mercury for approximately 30 minutes.
12. Accurately charge the system with the amount and type of refrigerant indicated on the freezer Model I.D. plate.
13. Leak check all fittings and connections.

7.6 DRIVE MOTOR INSTALLATION

To install a serviceable drive motor, perform the following procedures:

WARNING
DISCONNECT FREEZER FROM ELECTRICAL SUPPLY SOURCE BEFORE SERVICING.

1. With the necessary panels removed for removal of a defective drive motor, install the drive motor through either side of the freezer and position mounting flange over the bearing and line up the three holes.
2. Install the three socket head screws securing the mounting flange to the freezer and tighten.
3. Connect the wire leading from the drive motor to the reset switch.
4. Connect the lead wire to the drive motor capacitor.
5. Connect tension spring and adjust to 3 1/16"-3 1/8" (Fig.47).

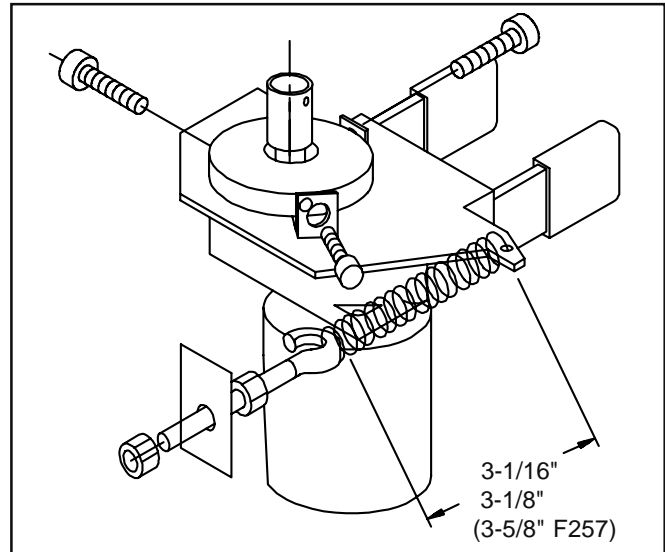

Figure 47. Tension Spring

6. Replace necessary panels.

7.7 CONDENSER FAN INSTALLATION

To install a serviceable condenser fan, perform the following procedures:

WARNING
DISCONNECT FREEZER FROM ELECTRICAL SUPPLY SOURCE BEFORE SERVICING.

1. Assuming the necessary panels have been removed to remove a defective condenser fan, install a new condenser fan bracket through the side of the freezer and align the holes in the fan brackets with the holes in the condenser fan shroud attached to the freezer frame (Fig.48).

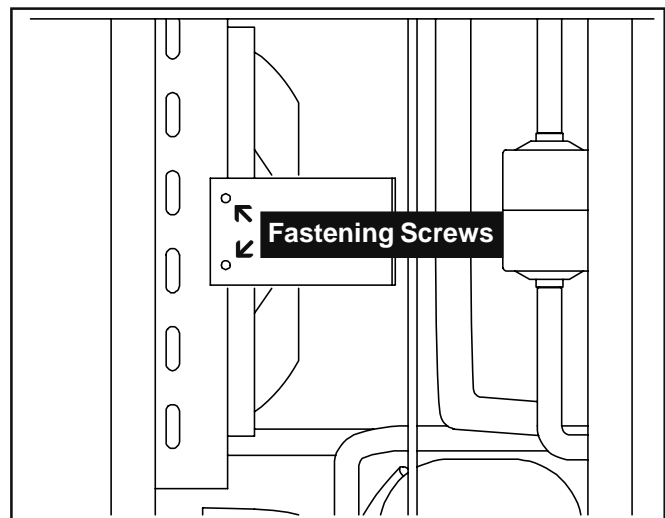

Figure 48. Fan Installation

2. Using a 5/16" nut driver or a phillips head screwdriver, install the four screws securing the fan supports to the mounting brackets.
3. Connect the condenser fan lead wires.

SECTION 8 TROUBLESHOOTING

Troubleshooting can be difficult. The TROUBLESHOOTING INDEX on the preceding page gives a list of possible problems. To make a repair to a problem, make reference to the cause and correction on the page indicated.

This list of problems causes and corrections will only give an indication of where a possible problem can be and what repairs are needed. Normally, more or other repair work is needed beyond the recommendations in the list.

Remember that a problem is not normally caused by only one part, but by the relation of one part with other parts. This list is only a guide and cannot give all possible problems and corrections. The technician must find the problem and its source, then make the necessary repairs.

In the event the Troubleshooting Guide does not help to correct the service problem, the factory Service Department should be contacted. Write or call:

STOELTING, INC.
502 HWY. 67
KIEL, WI 53042

Tele: 920-894-2293
800-558-5807
Fax: 920-894-7029

DESCRIPTION	INDEX	PAGE
8.1 Compressor run capacitor open, shorted or blown.....		35
8.2 Compressor relay defective or burned out		35
8.3 Compressor starts and runs, but short cycles on overload protector		35
8.4 Compressor runs continuously		35
8.5 Unit Noisy		35
8.6 Compressor will not start		35
8.7 Compressor will not start - hums but trips on overload protector		36
8.8 Compressor starts, but does not switch off of start winding		36
8.9 Compressor start capacitor open, shorted or blown		36
8.10 Freezer will not start		36
8.11 Drive motor overload trips (freezer shuts down when running)		36
8.12 Compressor will not run, but drive motor runs		36
8.13 Product dispenses incorrectly		36
8.14 Product is too thin		37
8.15 Agitator does not rotate		37
8.16 No ice crystals on initial freeze down		37
8.17 Excessive ice crystals above divider plate		37
8.18 Spigot leaking or stuck		37

8.1 COMPRESSOR RUN CAPACITOR OPEN, SHORTED, OR BLOWN

CAUSE

CORRECTION

Improper capacitor Determine correct size and replace.
Excessively high line voltage Contact your local power company
(110% of rated max.)

8.2 COMPRESSOR RELAY DEFECTIVE OR BURNED OUT

Incorrect relay Check and replace.
Incorrect mounting angle Remount relay in correct position.
Line voltage too high or too low Contact your local power company.
(+/- 10%)
Excessive short cycling Determine reason and correct.
Relay being influenced by loose vibrating mounting Remount rigidly.
Incorrect run capacitor Replace with proper capacitor.

8.3 COMPRESSOR STARTS AND RUNS, BUT SHORT CYCLES ON OVERLOAD PROTECTOR

Low voltage to unit Determine reason and correct.
Overload protector defective Replace overload.
Excessive discharge pressure Check ventilation, restrictions in cooling medium,
restrictions in refrigeration system.
Suction pressure too high Check for overcharge. Adjust or replace expansion valve.
Compressor too hot - return gas hot Check refrigerant charge (fix leak), add refrigerant if
necessary.
Compressor motor has a winding shorted Replace compressor.

8.4 COMPRESSOR RUNS CONTINUOUSLY

Shortage of refrigerant Fix leak, add refrigerant.
Torque control defective Check and replace torque control.
Mix in hopper too warm Refrigerant mix before adding to hopper.
Tension spring on torque Spring length should be 3-1/8" long. Adjust if necessary.
Restriction in refrigeration system Determine location and remove.
Restricted air flow to freezer Louvered panels require 6" (15.2 cm) clearance for air
intake and 10" (25.4 cm) clearance for discharge.
Filter dirty Clean or replace filter.
Fan not running Check fan and replace if necessary.
Dirty condenser Clean condenser.
Mix too rich Take "Brix" reading. Fill with properly mixed product.

8.5 UNIT NOISY

Drive cap will not stay in place Check locking pin inside of drive shaft and slot in agitator
for excessive wear and replace if necessary.
Loose parts or mountings Find and tighten.
Agitator drive shaft not lubricated Lubricate agitator drive shaft.
Tubing rattles Reform to be free of contact.
Mix too lean Fill product cylinder with properly mixed neutral base.
Bent fan causing vibration Replace fan.
Fan motor bearings worn Replace motor.
Agitator fingers are bent Realign or replace agitator and stationary fingers.
Internal compressor spring broken Replace compressor.
Lower agitator bushing is missing Install lower bushing.

8.6 COMPRESSOR WILL NOT START

Line disconnect switch open Close start or disconnect switch
Overload protector tripped Will reset after cooling.
Torque control defective Check and replace torque control.
Contactor defective Replace contactor.
Wiring improper or loose Check wiring against diagram.
24 Hour Timer not set for compressor operation Reset timer.

8.7 COMPRESSOR WILL NOT START - HUMS BUT TRIPS ON OVERLOAD PROTECTOR

- Improperly wired Check wiring against diagram.
- Low voltage to unit Determine reason and correct.
- Start capacitor defective Replace start capacitor.
- Relay failing to close Determine reason and correct. Replace relay if necessary.
- Compressor motor has a winding open or shorted Replace compressor.
- Internal mechanical trouble in compressor Replace compressor.

8.8 COMPRESSOR STARTS, BUT DOES NOT SWITCH OFF OF START WINDING

- Improperly wired Check wiring against diagram.
- Low voltage to unit Determine reason and correct.
- Excessive high discharge pressure Check for restrictions.
- Compressor motor has a winding open or shorted Replace compressor.
- Internal mechanical trouble in compressor Replace compressor.

8.9 COMPRESSOR START CAPACITOR OPEN, SHORTED OR BLOWN

- Relay failure Replace relay.
- Prolonged operation on start cycle due to low voltage to unit Determine reason and correct.
- Prolonged operation on start due to improper relay Replace relay.
- Excessive short cycling Determine reason and correct.
- Improper capacitor Determine correct size and replace.
- Loose wires Locate and correct.

8.10 FREEZER WILL NOT START

- Freezer is unplugged Plug in freezer.
- Toggle switch in OFF position Place toggle switch in ON or STIR ONLY position.
- Blown fuse or tripped circuit breaker in building Check for blown fuse or tripped circuit in building & replace.
- Reset switch is in the cut-out (down) position Put reset switch in normal operating position (up).
- ON-OFF-STIR ONLY switch has a loose wire or defective Check, repair, or replace switch.

8.11 DRIVE MOTOR OVERLOAD TRIPS (FREEZER SHUTS DOWN WHEN RUNNING)

- Dirty condenser Clean condenser.
- Improper Brix readings Refill with product that has Brix reading between 11-13.
- Consistency setting is too firm Adjust tension spring.
- Improper refrigerant charge Adjust charge.
- Large voltage changes Check supply voltage.
- Torque control not stopping compressor Check torque control.

8.12 COMPRESSOR WILL NOT RUN, BUT DRIVE MOTOR RUNS

- Voltage is too low Check voltage (See Nameplate).
- No power to compressor Check wire harness, terminal and switches in compressor circuit and replace or repair.
- Compressor start capacitor is defective Test capacitor and replace if necessary.
- Overload protector is tripped Check&test overload. If amps are normal, replace overload.
- Compressor relay if defective Test relay and replace if necessary.
- Toggle switch is in STIR ONLY position Place toggle switch in ON (the stirring & freezing)position.
- Compressor problem Refer to Subsections 8.1 through 8.9.
- Compressor is defective Check compressor and replace if necessary.
- Torque control defective Check and replace torque control.
- 24 Hour Timer not set for compressor operation Reset timer.

8.13 PRODUCT DISPENSES INCORRECTLY

- Trapped air under divider plate Remove trapped air.
- Lower half of cylinder is frozen to agitator Mix too lean. Thaw and refill with correct mix.
- Freezer is being overdrawn Slow down rate of draw.
- Upper half of cylinder is frozen Mix too lean in upper cylinder. Thaw/fill with correct mix.

8.14 PRODUCT IS TOO THIN

Ambient temperature is above 100°F (37.7°C)	Move or direct hot air away from freezer.
Freezer is being overdrawn	Slow down the rate of draw.
Condenser is dirty	Clean condenser.
Fan is stuck or motor is defective	Check, repair or replace.
Temperature adjusting tension spring too loose	Adjust tension spring.
Refrigerant is low or leaking	Check refrigerant charge. Add if necessary.
Expansion valve is defective	Check, adjust or replace expansion valve.

8.15 AGITATOR DOES NOT ROTATE

Drive cap pin not engaged or cap missing	Align half-holes in drive shaft and agitator tube.
Drive motor overload tripped off	Turn freezer off for 5 minutes, then reset.
Agitator stuck or frozen	Check for locked or bent fingers. Thaw product in freezer if frozen.
No power to drive motor	Check wire harness and switches in drive circuit and repair or replace.
Drive motor is defective	Check and replace if necessary.

8.16 NO ICE CRYSTALS ON INITIAL FREEZE DOWN

Toggle switch in OFF or STIR ONLY position	Place toggle switch in the stirring & freezing position.
Reset switch is in the cut-out (down) position	Place reset switch in normal operating position.
Blown fuse in building or no input power to freezer	Check for blown fuse or input power to freezer.
Broken wire, loose connection or defective switch	Check and test, repair or replace as necessary.
Mix too rich	Take "Brix" reading. Fill with properly mixed product.
Fan not running	Check fan and replace if necessary.
Restricted air flow to freezer	Louvered side panel required 6" (15.2 cm) clearance for air intake and top requires 10" (25.4 cm) clearance for discharge.
Dirty condenser filter	Clean filter.
Dirty condenser	Clean condenser.
Tension spring on torque control not set correctly	Spring length should be 3-1/16" - 3-1/8" long, 3-5/8" for the 2217G. Adjust if necessary.
Micro switch on torque control defective	Check and replace micro switch.
Shortage of refrigerant	Fix leak and add refrigerant.
24 Hour Timer not set for compressor operation	Reset timer.

8.17 EXCESSIVE ICE CRYSTALS ABOVE DIVIDER PLATE

Sealer ring not installed or installed incorrectly	Install sealer ring correctly.
Frozen product being poured into cylinder	Do Not pour frozen product into cylinder.
Lean mix	Drain mix. Refill with properly mixed product.

8.18 SPIGOT LEAKING OR STUCK

Spigot "O" rings defective or missing	Drain mix to below spigot level. Remove spigot, clean, replace o-rings as needed, lubricate and install.
Dried mix in spigot assembly	Drain mix to below spigot level. Remove spigot retainer and spigot. Disassemble/clean with hot water and brush. Lubricate, reassemble and install. Fill with liquid mix.

SECTION 9 REPLACEMENT PARTS AND REFERENCE DRAWINGS

The parts and wiring diagrams illustrated on the following pages pertain to models current with the printing of this manual.

For your convenience, a wiring diagram decal has been affixed to the electrical box or electrical box cover for your model.

If the wiring decal on your model is missing or has been damaged, please contact Stoelting, Inc. Service Department for a replacement.

9.1 HOW TO ORDER PARTS

To assure receipt of the proper replacement parts, supply your dealer or distributor with the following information:

- A. Model number of equipment.
- B. Serial number of model, stamped on nameplate.
- C. Part number, part name and quantity needed. Common parts names and numbers are listed in this manual.

9.2 SPIGOT ASSEMBLY PARTS

<u>Ref. No.</u>	<u>Part No.</u>	<u>Description</u>
1	1147688	Shaft & Plug Assembly (SM-813A)
2	1120265	Shaft Spacer
3	232002	Retainer Cap for Spigot Valve
4	624607	O-Ring
5	482024	Knob
6	694400	Spring
7	1120918	Splash Deflector for Spigot

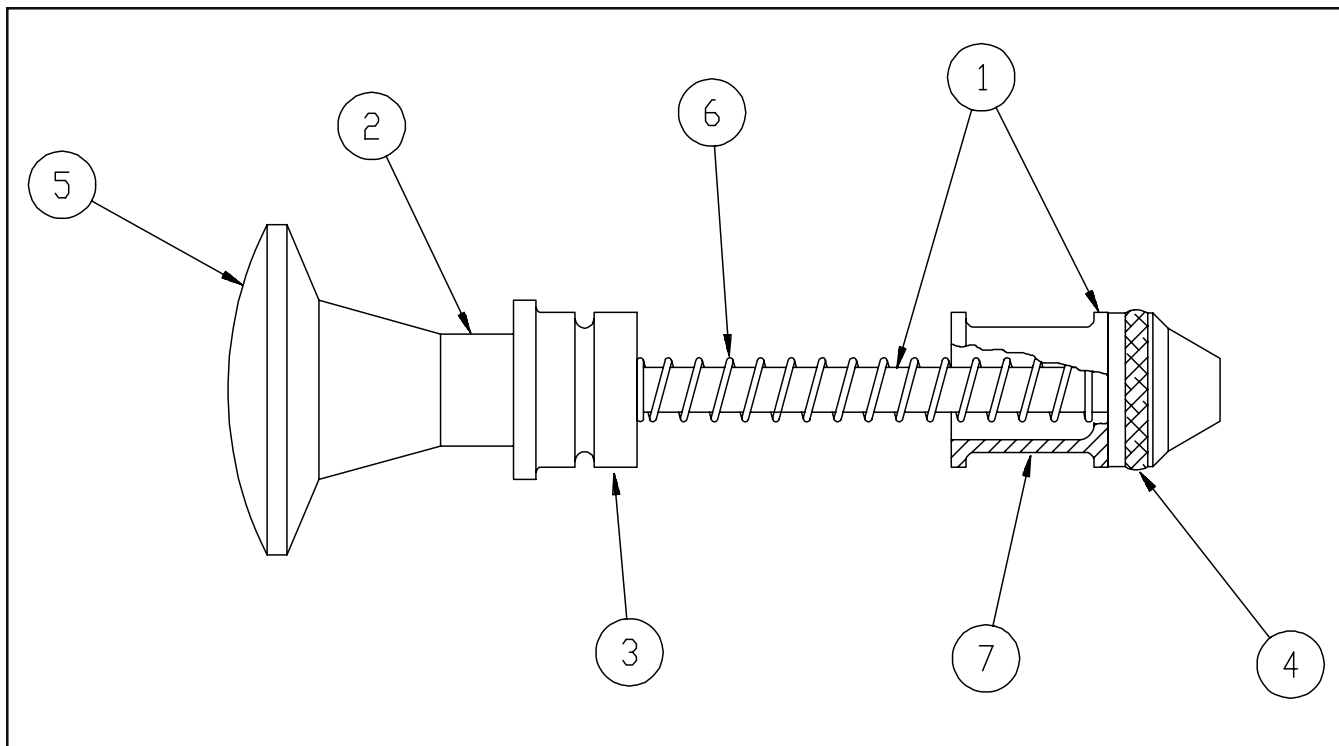

Figure 49. Exploded View of Spigot Assembly

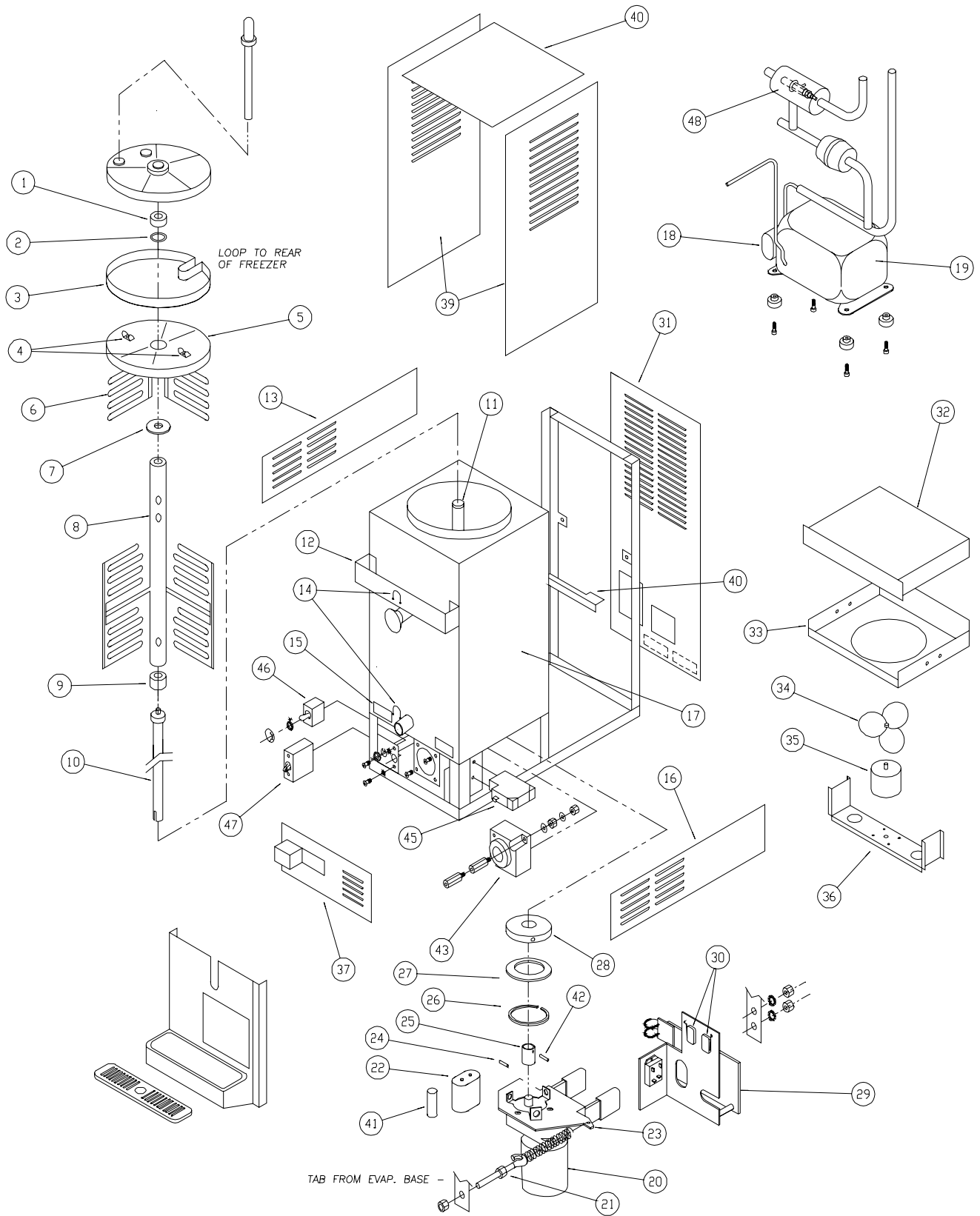

Figure 50. Model 100C Exploded View

9.3 MODEL 100C PARTS LIST

Ref. No.	Part No.	Description
1	232086	Drive Cap
2	624737	O-Ring, Agitator
3	5276	S.S. Sealer Ring
4	5309-12	Wing Nut
5	4111592	Divider Plate
6	2121522	Stationary Finger (Baffle Assembly)
7	767519	Anti-Lift Disc
8	4109212	Three Blade Agitator
9	221164	Bushing, Agitator (Bottom Center Post)
10	2171810	Drive Shaft
11	1127494	Bushing (Top Center Post)
12	3113940	Flavor Rack
13	2159570	Left Lower Panel
14	696130	Horseshoe Clip Lock Pin
15	324107	Decal
16	2159683	Right Lower Panel
17	3146277-01	Evaporator Assembly with Logo
18	618164	Copeland Relay
18	231092	Copeland Start Capacitor
19	282012	Compressor - Copeland
20	522031	Drive Unit Assembly
21	1133960	Torque Tension Spring & Eyebolt Assy.
22	231062	Capacitor, Drive Motor-current (97F 4287)
23	200037	Motor Mounting Plate
24	571016	Roll Pin (Bottom)
25	1171812	Drive Motor Extension
26	625456	Tru Arc Ring
27	766539	Washer (See #2149065 Bearing)
28	2149065	Bearing (See #766539 Washer)
29	294482-T	Electronic Torque control (Patented)
30	718149	Micro Switch for Electronic Torque Control
31	3158351	Back Panel
32	284010	Condenser
33	4158331	Fan Shroud
34	162070	Fan Blade
35	522833	Fan Motor
36	3156682	Fan Bracket
37	3159569	Front Panel
38	423013	Toggle Switch Cover (snap on)
39	3159478	Side Panel
40	3158345	Condenser Support
41	1170735	Capacitor Bracket
42	571020	Roll Pin (top)
43	739533	24 Hour Timer
44	3159479	Top Enclosure
45	718702	High Pressure Manual Reset Switch
46	718561	Toggle Switch
47	202002-T	Reset Switch (Circuit Breaker)
48	762411	Expansion Valve

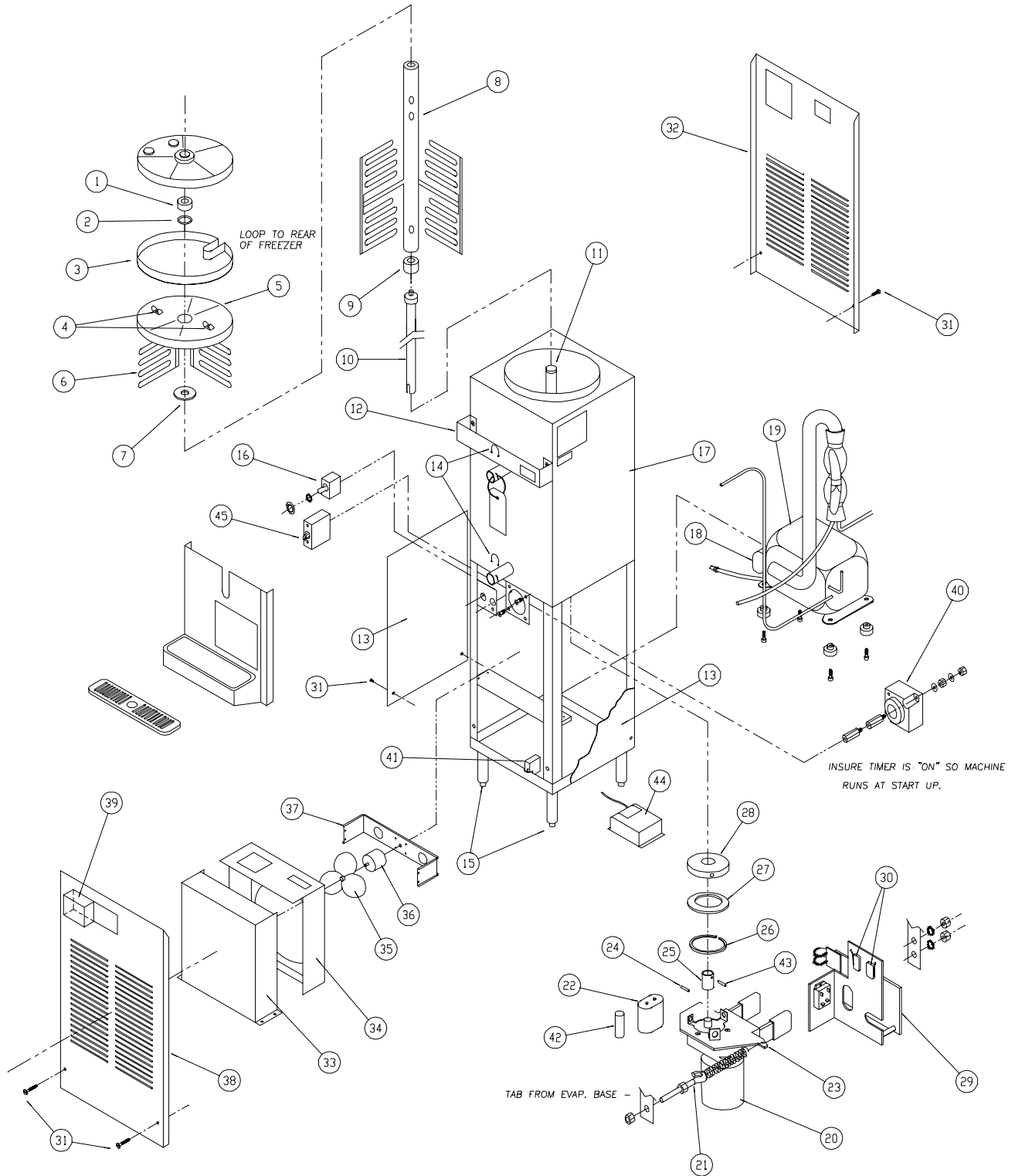

Figure 51. Model 100F Exploded View

9.4 MODEL 100F PARTS LIST

Ref.No.	Part Number	Description
1	232086	Drive Cap
2	624737	O-Ring, Agitator
3	5276	S.S. Sealer Ring
4	5309-12	Wing Nut
5	4111592	Divider Plate
6	2121522	Stationary Finger (Baffle Assembly)
7	767519	Anti-Life Disc
8	4109212	Three Blade Agitator
9	221164	Bushing, Agitator (Bottom Center Post)
10	2171810	Drive Shaft
11	1127494	Bushing (current - top of center post)
12	3113940	Flavor Rack
13	5332	R. and L. Side Panel, Lower - Floor Model
14	696130	Horseshoe Clip Lock Pin
15	490701	Leg Tip - Die Cast Aluminum
16	718561	Toggle Switch
17	3146277-01	Evaporator Assembly
18	231092	Copeland Start Capacitor
18	618164	Copeland Relay
19	282012-SV	Compressor - Copeland
20	522031	Drive Unit Assembly (WSM) cannot be used on Counter Model
21	5691	Torque Tension Spring & Mounting Hardware
22	231062	Capacitor, Drive Motor-current (97F 4287)
23	200037	Motor Mounting Plate
24	571016	Roll Pin (Bottom)
25	1171812	Drive Motor Extension
26	625456	Tru Arc Ring
27	766539	Washer (See #2149065 Bearing)
28	2149065	Bearing (See #766539 Washer)
29	294482-T	Electronic Torque Control (Patented)
30	718149	Micro Switch for Electronic Torque Control
31	649175	Panel Screw
32	3149024	Rear Lower Panel
33	284010	Condenser
34	4158331	Metal Fan Shroud
35	162070	Fan Blade, Condenser
36	522833	Fan Motor, Condenser
37	3156682	Fan Bracket
38	3159575	Front Lower Panel with Slots
39	423013	Toggle Switch Cover (snap on)
40	739533	24 Hour Timer
41	718702	High Pressure Manual Reset Switch
42	1170735	Capacitor Bracket
43	571020	Roll Pin (top)
44	744038	Transformer
45	202002-T	Reset Switch, Circuit Breaker

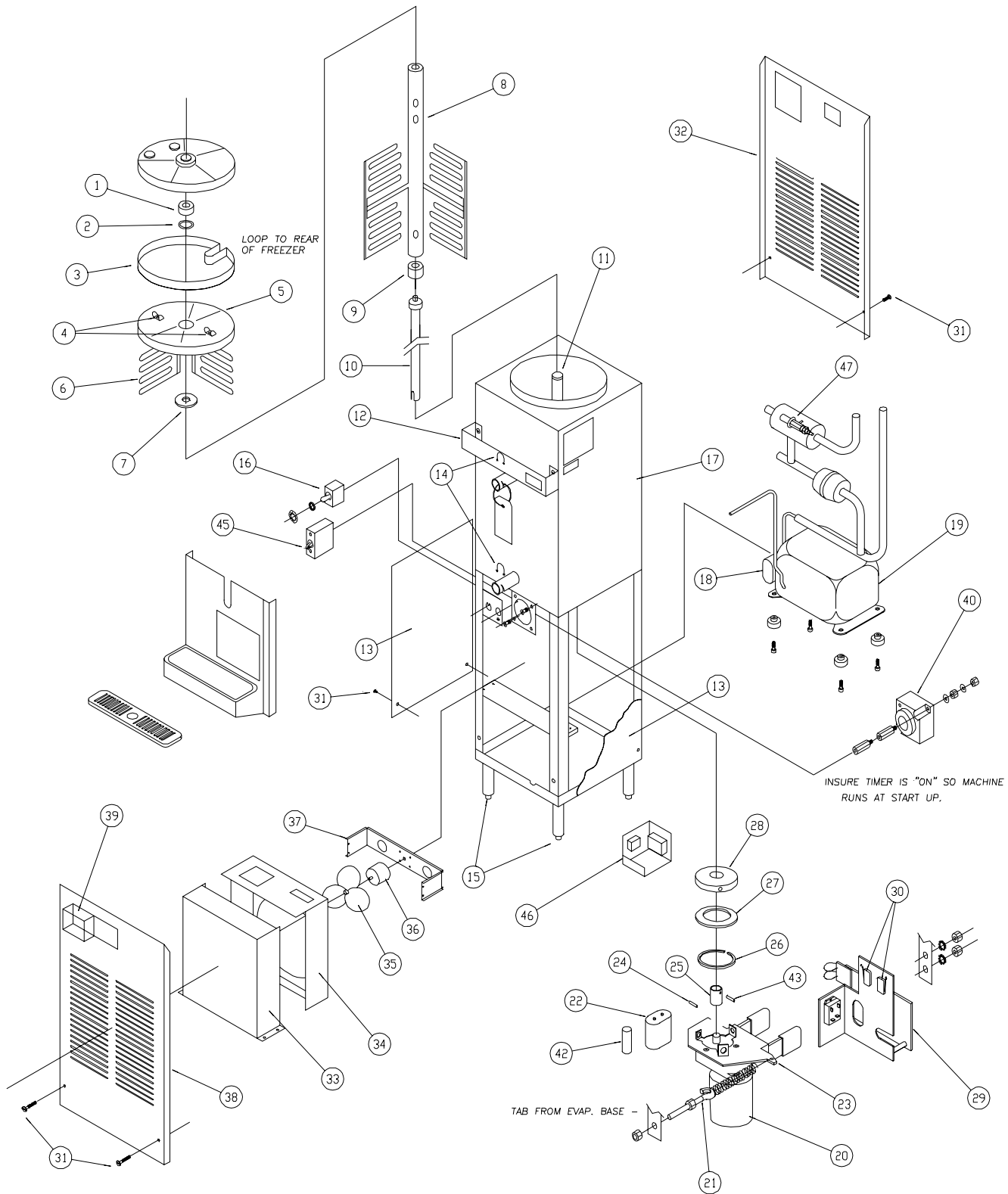

Figure 52. Model 2217G Exploded View

9.5 MODEL 2217G PARTS LIST

<u>Ref. No.</u>	<u>Part No.</u>	<u>Description</u>
1	232086	Drive Cap
2	624737	O-Ring, Agitator
3	5276	S.S. Sealer Ring
4	5309-12	Wing Nut
5	4111592	Divider Plate
6	2146244	Stationary Finger (Baffle Assembly)
7	2146251	Anti-Lift Disc
8	4146238	Three Blade Agitator
9	1142520	Bushing, Agitator (Bottom Center Post)
10	2171810	Drive Shaft
11	1127494	Bushing (Current - Top Center Post)
12	3113940	Flavor Rack
13	5332	R. and L.Side Panel, Lower - Floor Model
14	696130	Horseshoe Clip Lock Pin
15	490701	Leg Tip - Die Cast Aluminum
16	718561	Toggle Switch
17	3146277-01	Evaporator Assembly (w/logo)
18	230624	Start Capacitor (Ser.#1519 Plus)
18	618530	Relay (Ser.#1519 Plus)
18	231073	Start Capacitor (Ser.#1357 - #1518)
18	231044	Run Capacitor (Ser. #0 - #1356)
18	231060	Start Capacitor (Ser. #0 - #1356)
18	231022	Start Capacitor (50 Hz.)
18	231072	Run Capacitor (50 Hz.)
18	618488	Relay Overload (Ser. #1519 Plus)
18	618145	Relay (Ser. #1357 - #1518)
18	618446	Relay Overload (Ser. #1357 - #1518)
18	618146	Relay (50 Hz.)
19	282022	Compressor Tecumseh (w/Caps.)(Ser.#1519 Plus)(60 Hz.)
19	282209-01	Compressor Copeland (Ser.#1357 - #1518)(60 Hz.)
19	282284-01	Compressor Tecumseh (Ser. #0 - #1356)(60 Hz.)
19	282210	Compressor Copeland (No Caps.)(50 Hz.)
20	522031	Drive Unit Assembly (WSM) cannot be used on Counter Model
21	5691	Torque Tension Spring & Mounting Hardware
22	231062	Capacitor, Drive Motor - current (97F 4287)
23	200037	Motor Mounting Plate
24	571016	Roll Pin (Bottom)
25	1171812	Drive Motor Extension
26	625456	Tru Arc Ring
27	766539	Washer (See #2149065 Bearing)
28	2149065	Bearing (See #766539 Washer)
29	294482-T	Electronic Torque Control (Patented)
30	718149	Micro Switch for Electronic Torque Control
31	649175	Panel Screw (Ser. #1519 Plus)
31	647886	Panel Screw (Ser. #0 - #1518)
32	3149024	Rear Lower Panel (Ser. #1519 Plus)
32	3149015	Rear Lower Panel (Ser. #0 - #1518)
33	284010	Condenser (Ser. #1519 Plus)
33	284013	Condenser (Ser. #0 - #1518)
34	4158331	Metal Fan Shroud
35	162070	Fan Blade, Condenser
36	522833	Fan Motor, Condenser
37	3156682	Fan Bracket
38	3159575	Front Lower Panel with Slots
39	423013	Toggle Switch Cover (snap on)
40	739533	24 Hour Timer

<u>Ref. No.</u>	<u>Part No.</u>	<u>Description</u>
42	1170735	Capacitor Bracket
43	571020	Roll Pin (top)
45	202002-T	Reset Switch, Circuit Breaker
46	295019	Contactors
47	762411	Expansion Valve