



**Model SF121I2 / SF144I2**  
**SERVICE MANUAL**

Manual No. 513681

Rev.0



This manual provides basic information about the machine. Instructions and suggestions are given covering its operation and care.

The illustrations and specifications are not binding in detail. We reserve the right to make changes to the machine without notice, and without incurring any obligation to modify or provide new parts for machines built prior to date of change.

**DO NOT ATTEMPT** to operate the machine until instructions and safety precautions in this manual are read completely and are thoroughly understood. If problems develop or questions arise in connection with installation, operation, or servicing of the machine, contact Stoelting.



[stoeltingfoodservice.com](http://stoeltingfoodservice.com)

Stoelting Foodservice Equipment  
502 Highway 67  
Kiel, WI 53042-1600  
U.S.A.

Main Tel: 800.558.5807  
Fax: 920.894.7029

Customer Service: 888.429.5920  
Fax: 800.545.0662  
Email: [foodservice@stoelting.com](mailto:foodservice@stoelting.com)

© 2014 PW Stoelting, LLC

---

## ***A Few Words About Safety***

### **Safety Information**

**Read and understand the entire manual before operating or maintaining Stoelting equipment.**

This manual provides the operator with information for the safe operation and maintenance of Stoelting equipment. As with any machine, there are hazards associated with their operation. For this reason safety is emphasized throughout the manual. To highlight specific safety information, the following safety definitions are provided to assist the reader.

The purpose of safety symbols is to attract your attention to possible dangers. The safety symbols, and their explanations, deserve your careful attention and understanding. The safety warnings do not by themselves eliminate any danger. The instructions or warnings they give are not substitutes for proper accident prevention measures.

If you need to replace a part, use genuine Stoelting parts with the correct part number or an equivalent part. We strongly recommend that you do not use replacement parts of inferior quality.



### **Safety Alert Symbol:**

**This symbol** Indicates danger, warning or caution. Attention is required in order to avoid serious personal injury. The message that follows the symbol contains important information about safety.

### **Signal Word:**

Signal words are distinctive words used throughout this manual that alert the reader to the existence and relative degree of a hazard.



The signal word "WARNING" indicates a potentially hazardous situation, which, if not avoided, may result in death or serious injury and equipment/property damage.



The signal word "CAUTION" indicates a potentially hazardous situation, which, if not avoided, may result in minor or moderate injury and equipment/property damage.

### **CAUTION**

The signal word "CAUTION" not preceded by the safety alert symbol indicates a potentially hazardous situation, which, if not avoided, may result in equipment/property damage.

### **NOTE (or NOTICE)**

The signal word "NOTICE" indicates information or procedures that relate directly or indirectly to the safety of personnel or equipment/property.

# TABLE OF CONTENTS

<b>Section</b>	<b>Description</b>	<b>Page</b>
<b>1</b>	<b>Description And Specifications</b>	
1.1	Description.....	1
1.2	Specifications .....	1
1.3	Component Settings .....	3
<b>2</b>	<b>Refrigeration Diagram and Wiring Diagrams</b>	
2.1	Refrigeration Diagram .....	5
2.2	Wiring Diagram.....	6
<b>3</b>	<b>Replacement Parts</b>	
3.1	Brushes, Decals and Lubrication.....	11
3.2	Spigot Extension.....	11
3.3	Auger Shaft and Front Door .....	12
3.4	Blender Parts .....	14
3.5	Spigot Cam Assembly .....	15
3.6	Stainless Steel Panels.....	15
3.7	Rear (Air Cooled).....	16
3.8	Left Side .....	17
3.9	Front (Water Cooled .....	18
3.10	Electrical Components.....	19



# SECTION 1 INTRODUCTION

## 1.1 DESCRIPTION

The Stoelting F144I2, SF144I2 and SF121I2 counter-top machines are gravity fed. The machines are equipped with the IntelliTec2™ control which provides a uniform product. The machines are designed to operate with almost any type of commercial soft serve or non-dairy mixes available, including: ice milk, ice cream, yogurt, and frozen dietary desserts.

This manual is designed to assist qualified service personnel and operators in the installation, operation and maintenance of the Stoelting F144I2, SF144I2 and SF121I2 gravity machines.



**Figure 1-1 Model SF144 I2**

## 1.2 SPECIFICATIONS

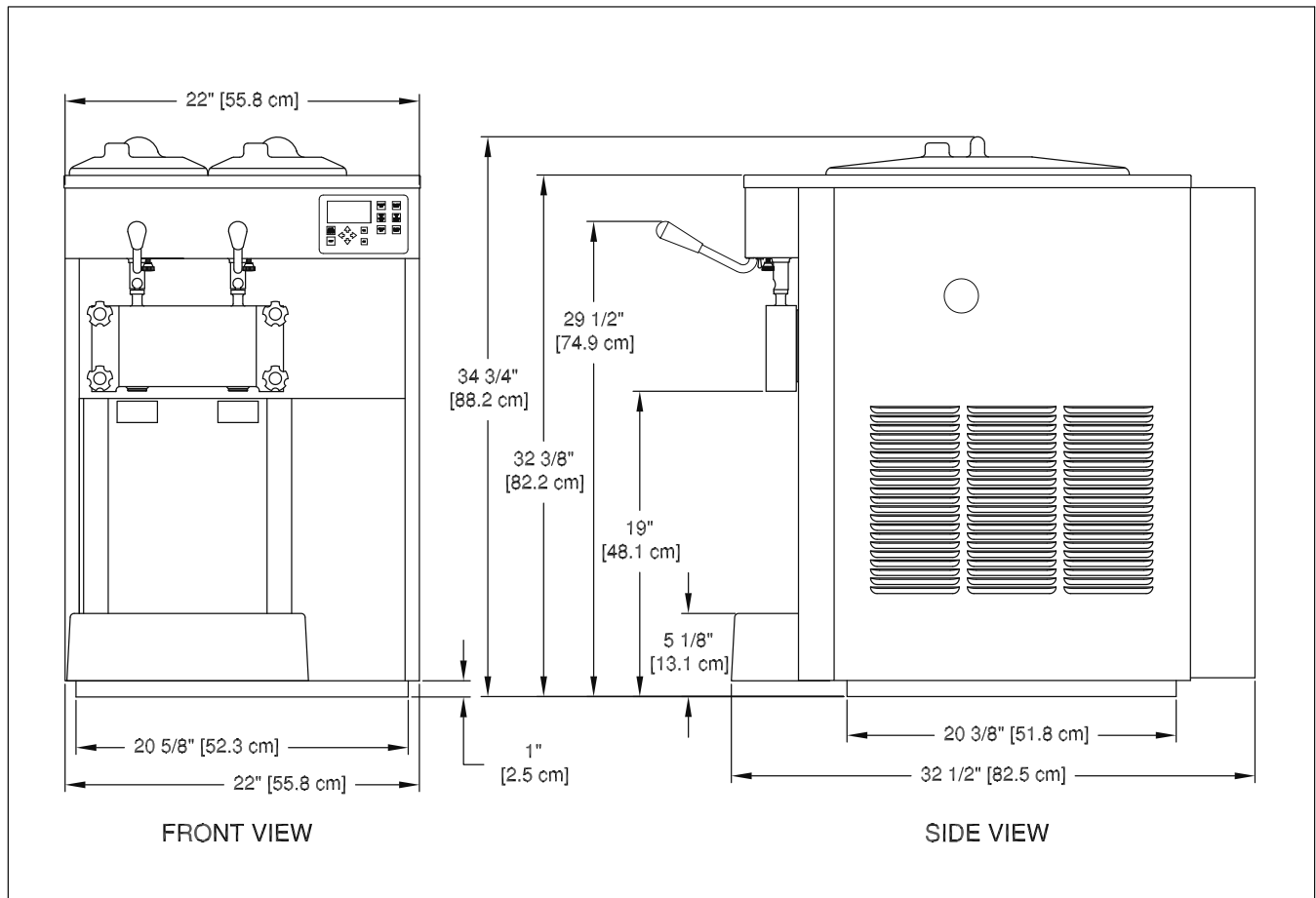

**Figure 1-2 Specification**

## 1.2 SPECIFICATIONS

<b>Model F144 I2 / SF144 I2</b>		
<b>Dimensions</b>	<b>Machine</b>	<b>with crate</b>
width	22" (55,9 cm)	28" (71,1 cm)
height	34-3/4" (88,3 cm)	40-1/4" (102,2 cm)
depth	28-1/2" (72,4 cm)	35-1/4" (89,5 cm)
<b>Weight</b>	385 lbs (174,6 kg)	470 lbs (213,1 kg)
<b>Electrical</b>	<b>1 Phase, 208-240 VAC, 60Hz</b>	<b>3 Phase, 208-240 VAC, 60Hz</b>
running amps	12A	10A
connection type	NEMA6-20P power cord provided	NEMA L15-20P power cord provided
International Option	1 Phase, 220-240 VAC, 50Hz	
<b>Compressor</b>	12,000 Btu/hr	
<b>Drive Motor</b>	Two - 3/4 hp	
<b>Air Flow</b>	Air cooled units require 3" (7,6 cm) air space on both sides	
<b>Plumbing Fittings</b>	Water cooled units require 3/8" N.P.T. water and drain fittings.	
<b>Hopper Volume</b>	Two - 3 gallon (11,35 liters)	
<b>Freezing Cylinder Volume</b>	Two - 0.85 gallon (3,22 liters)	

<b>SF144 I2</b>	
<b>Refrigerant</b>	R-404A
<b>Charge</b>	(W/C) 32 oz (A/C) 42 oz
<b>Suction Pressure (at 72°F)</b>	One Cylinder 18-22 psig Hopper Only 14 psig
<b>Discharge Pressure</b>	225-235 psig
<b>Hot Gas Bypass Pressure</b>	14 psig (only hopper running)
<b>EPR Valve</b>	59-61 psig



<b>Model SF121 I2</b>		
<b>Dimensions</b> width height depth	<b>Machine</b>	<b>with crate</b>
	22" (55,9 cm)	28" (71,1 cm)
	34-3/4" (88,3 cm)	40-1/4" (102,2 cm)
	28-1/2" (72,4 cm)	35-1/4" (89,5 cm)
<b>Weight</b>	385 lbs (174,6 kg)	470 lbs (213,1 kg)
<b>Electrical</b> running amps connection type	<b>1 Phase, 208-240 VAC, 60Hz</b> 12A NEMA6-20P power cord provided	<b>3 Phase, 208-240 VAC, 60Hz</b> 10A NEMA L15-20P power cord provided
	International Option 1 Phase, 220-240 VAC, 50Hz	
<b>Compressor</b>	12,000 Btu/hr	
<b>Drive Motor</b>	Two - 3/4 hp	
<b>Air Flow</b>	Air cooled units require 3" (7,6 cm) air space on both sides	
<b>Plumbing Fittings</b>	Water cooled units require 3/8" N.P.T. water and drain fittings.	
<b>Hopper Volume</b>	Two - 3 gallon (11,35 liters)	
<b>Freezing Cylinder Volume</b>	Two - 0.85 gallon (3,22 liters)	

<b>SF121 I2</b>	
<b>Refrigerant</b>	R-404A
<b>Charge</b>	(W/C) 32 oz (A/C) 42 oz
<b>Suction Pressure (at 72°F)</b>	One Cylinder 18-22 psig Hopper Only 14 psig
<b>Discharge Pressure</b>	225-235 psig
<b>Hot Gas Bypass Pressure</b>	14 psig (only hopper running)
<b>EPR Valve</b>	59-61 psig

### 1.3 COMPONENT SETTINGS

Following are the settings for the components in the SF121 I2 and SF144 I2 machines.

#### A. COMPRESSOR WINDINGS

When testing the compressor windings the resistance through the windings should be as follows:

Compressor	Electrical	S to C	R to C
282032	1 PH	3.10Ω	1.16Ω
282033	3 PH	1.77Ω	0.00Ω

#### B. CAPACITORS

Refer to the following table for the capacitance of all the capacitors in the machine:

Capacitor	Part	Rating	
		MFD	VAC
Compressors - Start	231079	145-174 MFD	220 VAC
Compressor - Run	231084	30 MFD	370 VAC
Motor - Start	231095	500 MFD	125 VAC
Motor - Run	231078	50 MFD	370 VAC

### D. TEMPERATURE CONTROL SENSOR

The following table shows the relationship between the thermistor resistance and the suction line temperature.

°F	Resistance	°F	Resistance
-22	176950	40	26100
-20	165200	42	24725
-18	154300	44	23400
-16	144200	46	22175
-14	134825	48	21000
-12	126125	50	19900
-10	118050	52	18875
-8	110550	54	17900
-6	103550	56	17000
-4	97075	58	16125
-2	91025	60	15325
0	85400	62	14550
2	80150	64	13825
4	75275	66	13150
6	70725	68	12500
8	66475	70	11875
10	62500	72	11300
12	58800	74	10750
14	55325	76	10250
16	52100	78	9750
18	49075	80	9300
20	46250	82	8850
22	43600	84	8450
24	41125	86	8050
26	38800	88	7675
28	36625	90	7325
30	34575	92	7000
32	32675	94	6675
34	30875	96	6375
36	29175	98	6100
38	27600	100	5825

# SECTION 2 REFRIGERATION DIAGRAM AND WIRING DIAGRAMS

## 2.1 REFRIGERATION DIAGRAM

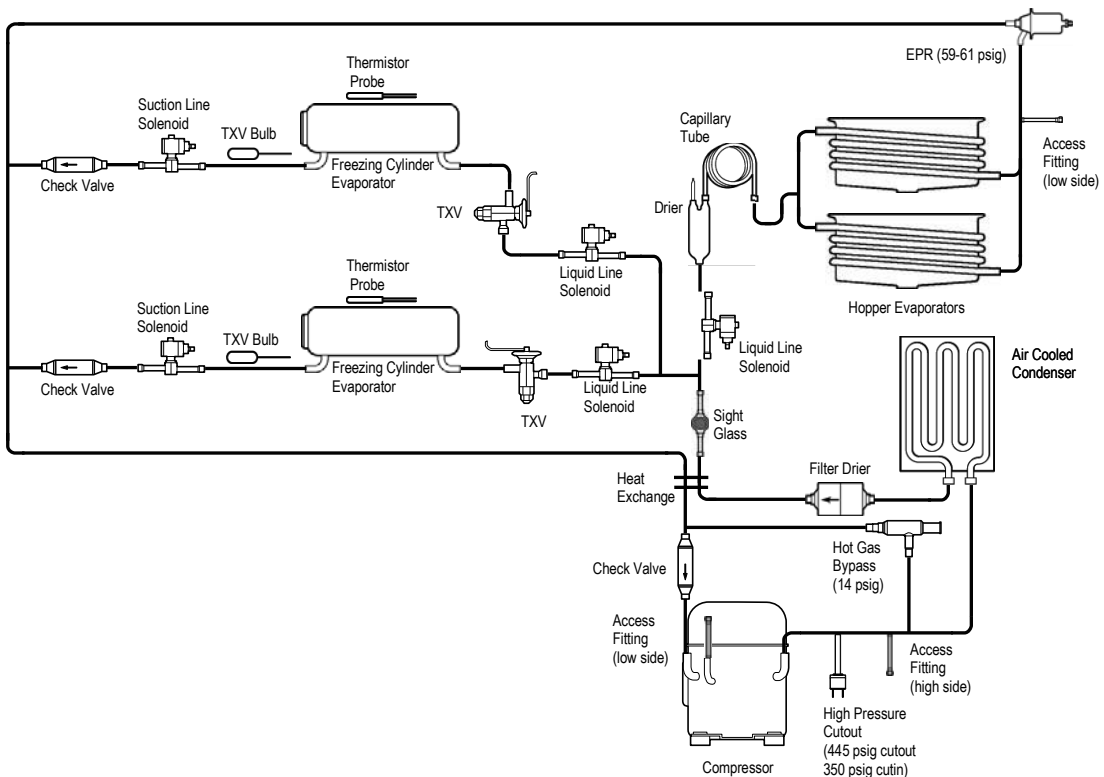
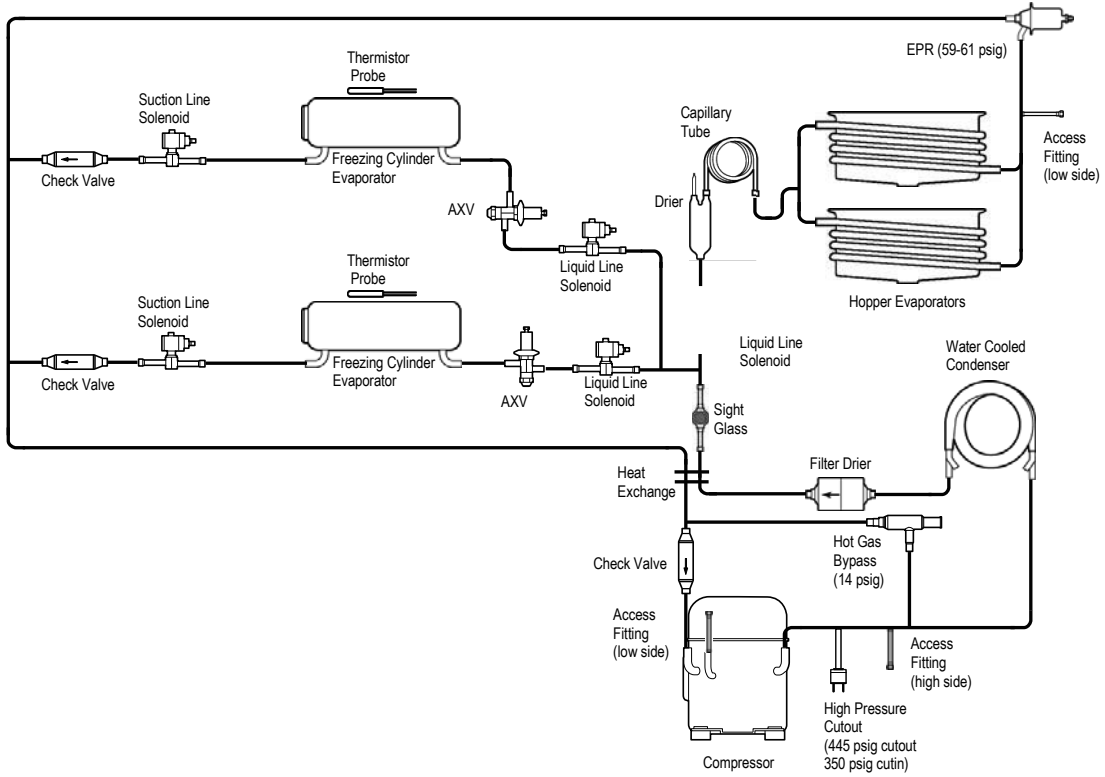

## 2.2 WIRING DIAGRAM

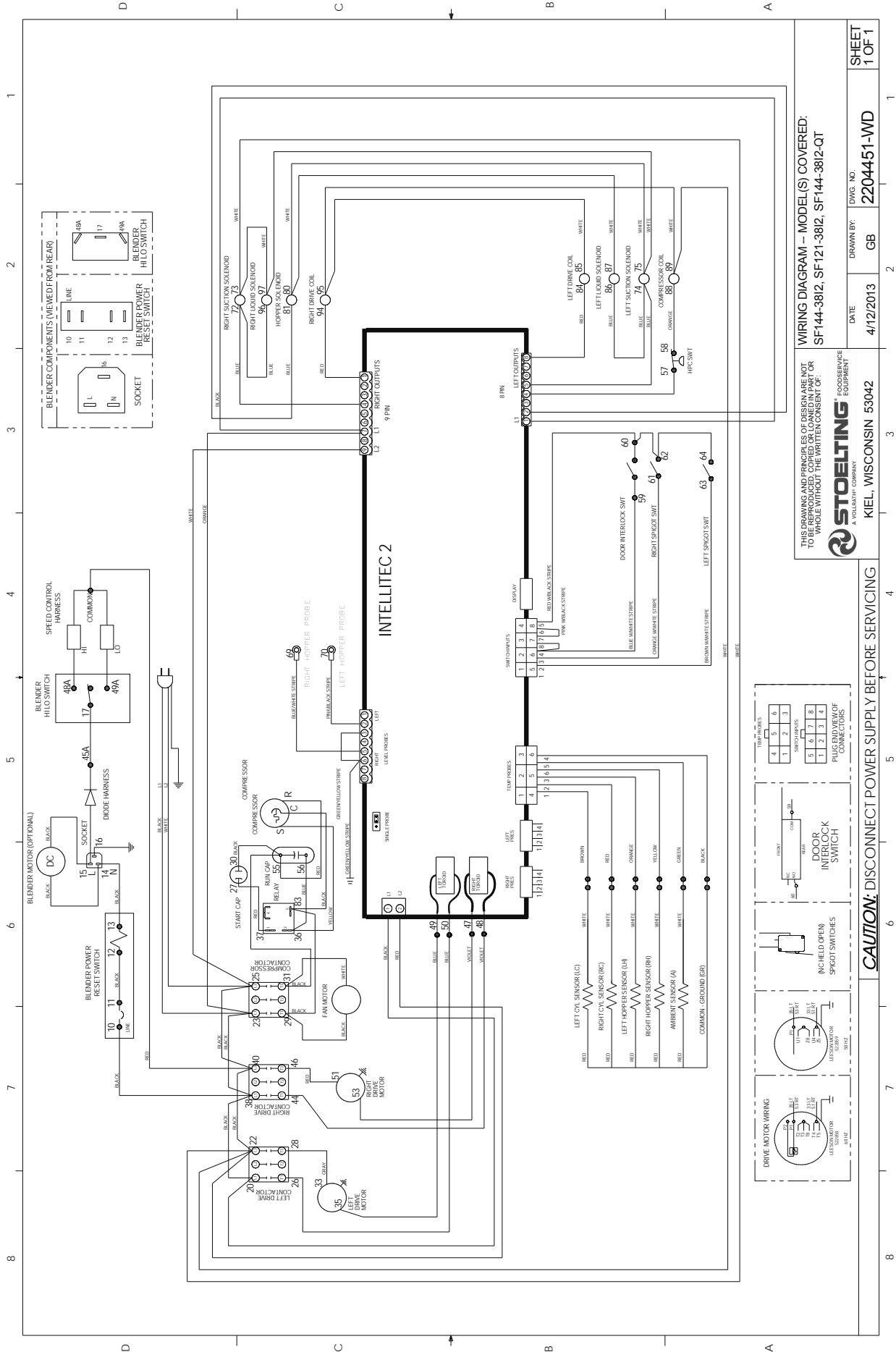

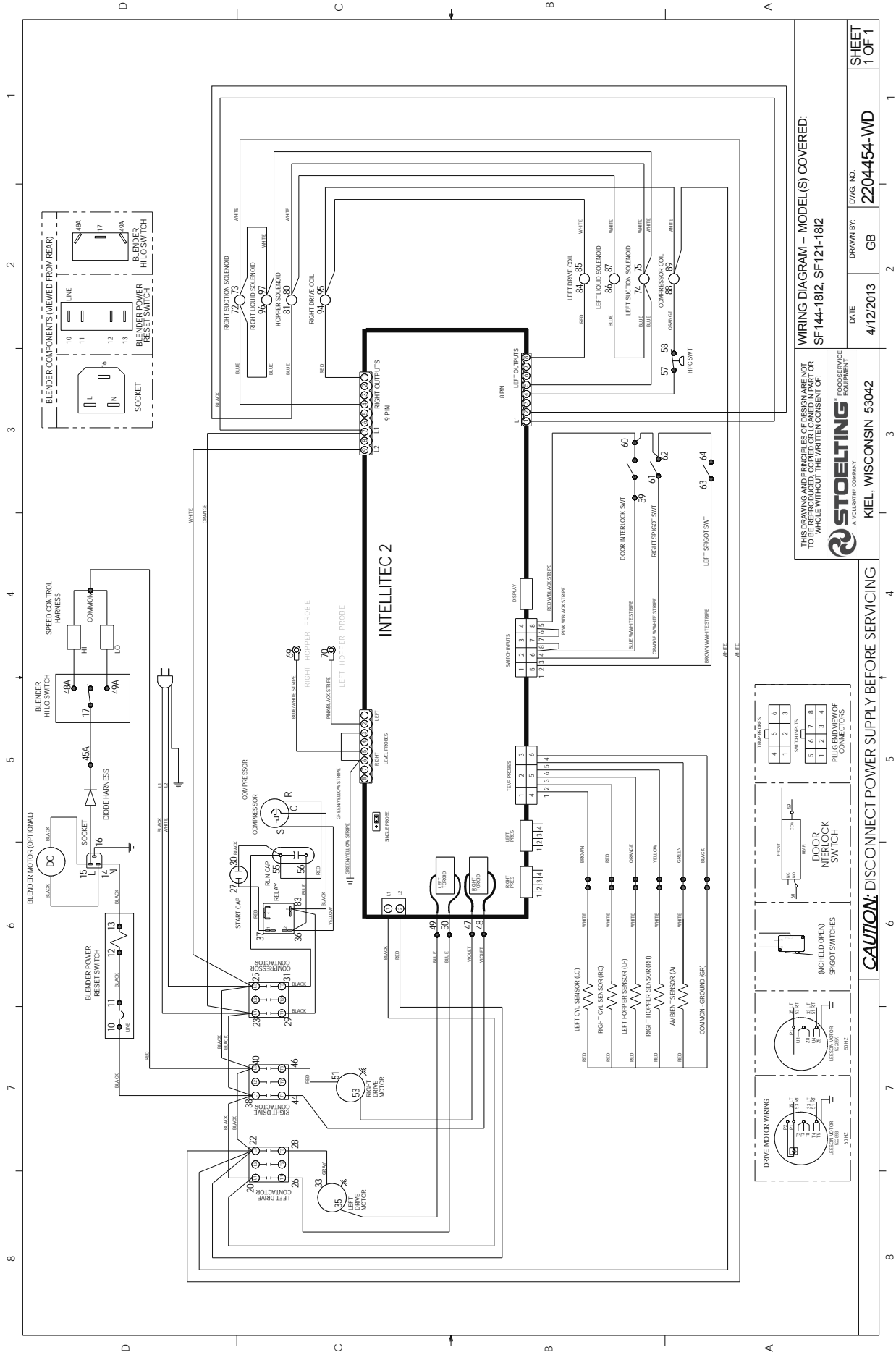

WIRING DIAGRAM - MODEL(S) COVERED:  
SF144-1812, SF121-1812

THIS DRAWING AND PRINCIPLES OF DESIGN ARE NOT TO BE REPRODUCED OR TRANSMITTED IN ANY FORM OR BY ANY MEANS, ELECTRONIC OR MECHANICAL, INCLUDING PHOTOCOPYING, RECORDING, OR BY ANY INFORMATION STORAGE AND RETRIEVAL SYSTEM, WITHOUT THE WRITTEN CONSENT OF:  
**STOELTING** FOODSERVICE EQUIPMENT  
A VOLVOVEHT COMPANY  
KIEL, WISCONSIN 53042

DATE: 4/12/2013  
DRAWN BY: GB  
DWG. NO.: 2204454-WD

DATE: 4/12/2013  
DRAWN BY: GB  
DWG. NO.: 2204454-WD

**CAUTION: DISCONNECT POWER SUPPLY BEFORE SERVICING**

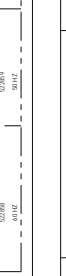

DATE: 4/12/2013  
DRAWN BY: GB  
DWG. NO.: 2204454-WD

SHEET 1 OF 1

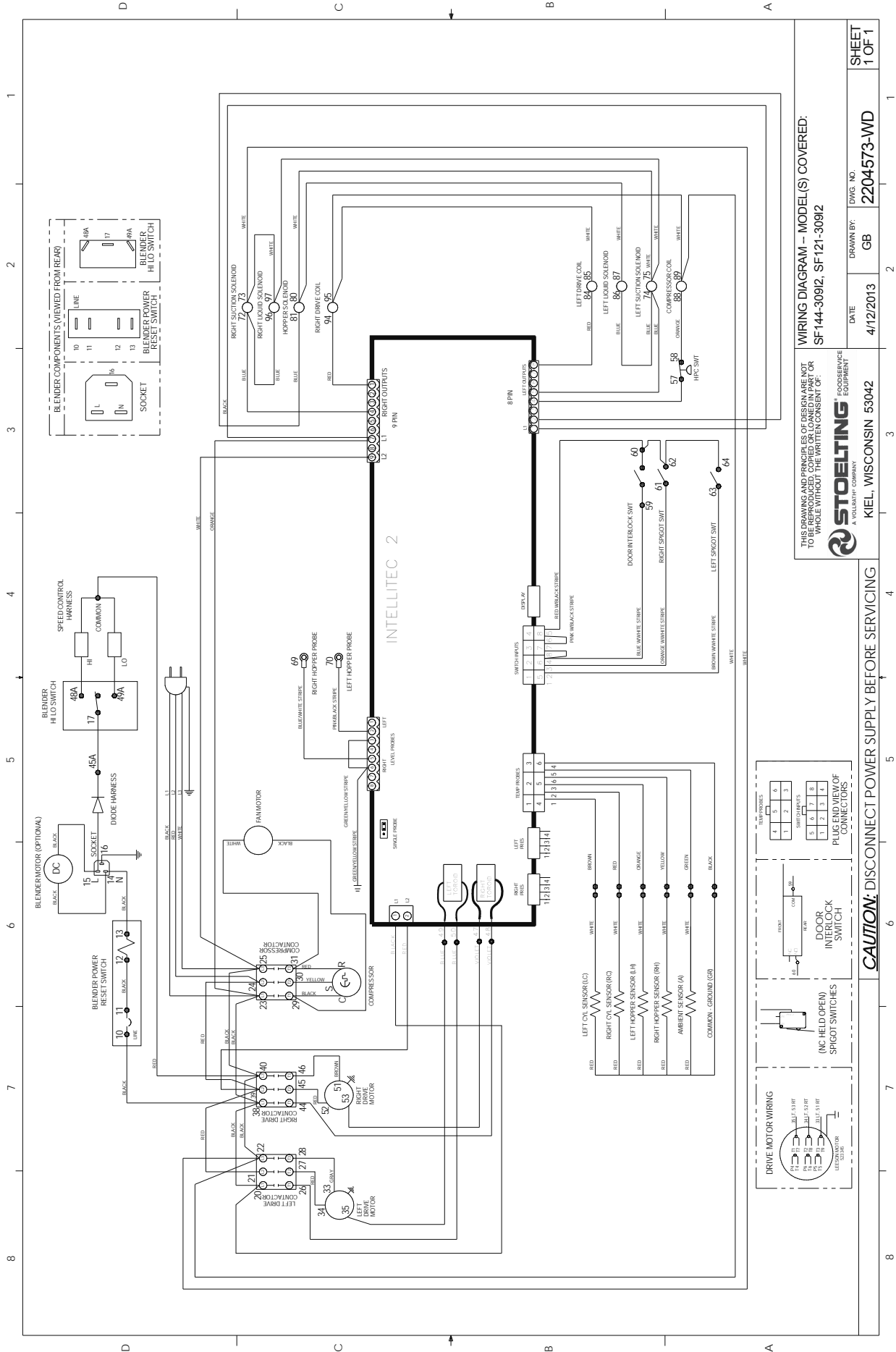

WIRING DIAGRAM - MODEL(S) COVERED:  
SF144-30912, SF121-30912

THIS DRAWING AND PRINCIPLES OF DESIGN ARE NOT TO BE REPRODUCED OR TRANSMITTED IN ANY FORM OR BY ANY MEANS, ELECTRONIC OR MECHANICAL, INCLUDING PHOTOCOPYING, RECORDING, OR BY ANY INFORMATION STORAGE AND RETRIEVAL SYSTEM, WITHOUT THE WRITTEN CONSENT OF:  
**STOELTING** FOODSERVICE EQUIPMENT  
A VOLLEBERT COMPANY  
KIEL, WISCONSIN 53042

DATE	4/12/2013	DRAWN BY:	GB	DWG. NO.	2204573-WD
					SHEET
					1 OF 1

**CAUTION: DISCONNECT POWER SUPPLY BEFORE SERVICING**

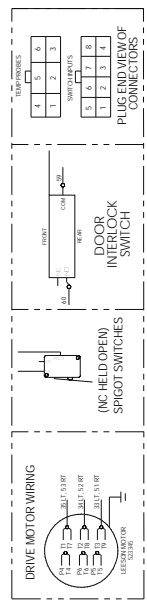

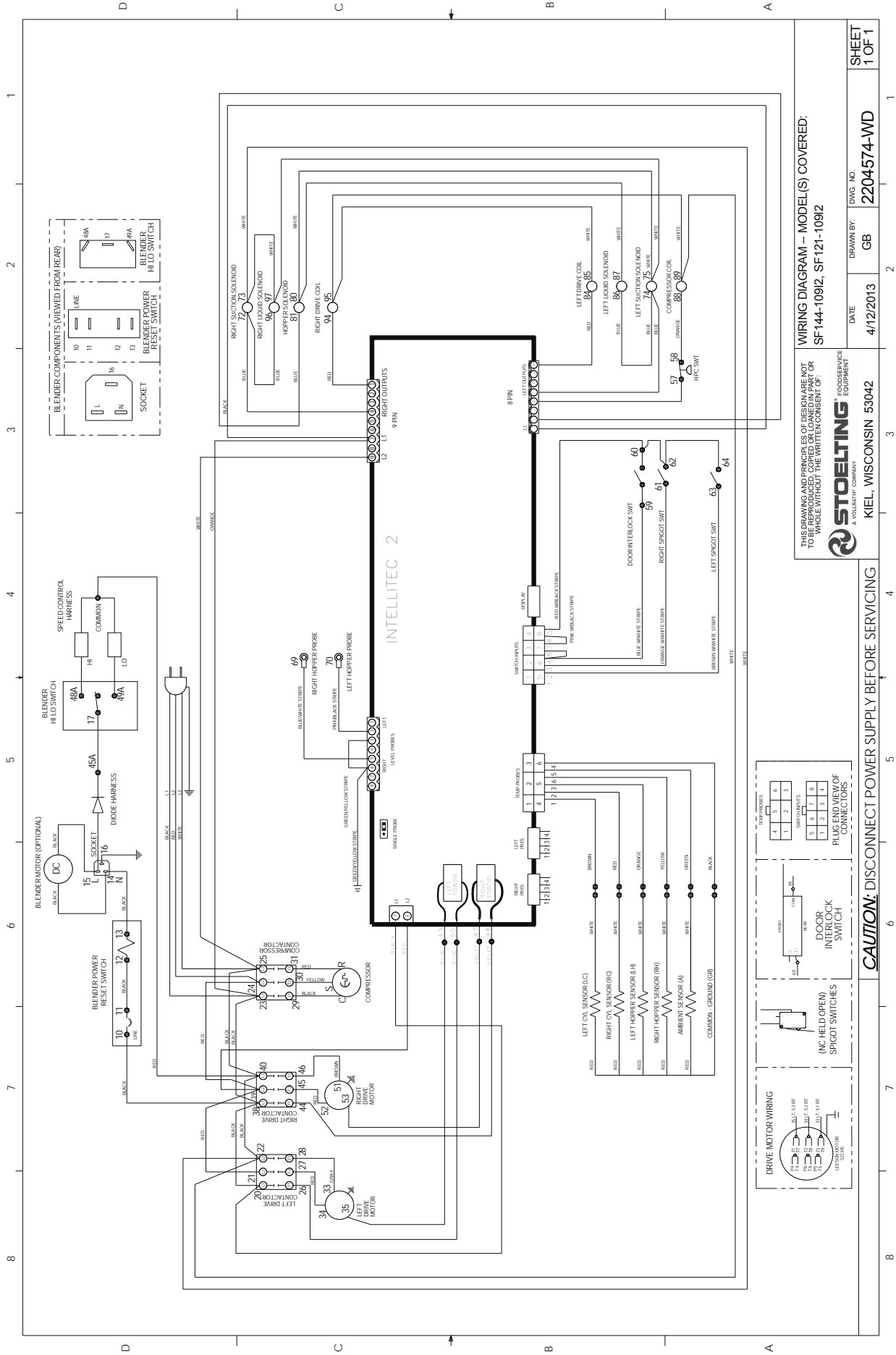





## SECTION 3 REPLACEMENT PARTS

### 3.1 BRUSHES, DECALS AND LUBRICATION

Part	Description	Quantity
208135	Brush - 4" X 8" X 16" (Barrel)	1
208380	Brush - 1/4" X 3" X 14"	1
208401	Brush - 1" X 3" X 10"	1
208467	Brush - 3/8" X 1" X 5"	1
232091	Cap - Protective (Gray) - #490716 Leg	4
236025	Card - Cleaning Instruction	1
266076	Clip - Drip Tray	2
324065	Decal - Water Inlet	1
324105	Decal - Caution Electrical Shock	3
324106	Decal - Caution Electrical Wiring Materials	1
324107	Decal - Caution Hazardous Moving Parts	2
324141	Decal - Caution Rotating Blades	1
324208	Decal - Attention Refrigerant Leak Check	2
324509	Decal - Cleaning Instructions	1
324566	Decal - Wired According To	1
324584	Decal - Adequate Ventilation 3"	2
324594	Decal - Heat Sensitive	4
324686	Decal - Danger Automatic Start	1
324803	Decal - Domed Stoelting Logo (Large) (Header Panel)	1
324833	Decal - Ice Cream (SF144)	1
324835	Decal - Blender Power On/Off	1
324836	Decal - Blender High/Low	1
324837	Decal - Caution Blender	1
324839	Decal - Ground	1
324909	Decal - USB Port	1
324922	Decal - Assembly Check	1
324926	Decal - Milkshake (SF144)	1
324940	Decal - Thermistor ID	1
396241	Gasket - Freezer Base	1
490716	Leg	4
508048	Lubricant - Spline (2 oz Squeeze Tube)	1
508135	Petrol Gel - 4 oz Tube	1
513677	Manual - Owner's	1
636080	DVD - IntelliTec2 Training	1
1159501	O-Ring & Bushing Kit	-
2177917	Brush Kit	-

### 3.2 SPIGOT EXTENSION

Part	Description	Quantity
232734	Cap - Rosette	4
624677-5	O-Ring - Spigot Extension - Black (5 Pack)	3
2177072	Extension - Spigot - 1.5"	-
2177073	Extension - Spigot - 2.5"	3
2177074	Extension - Spigot - 3.2"	-

### 3.3 AUGER SHAFT AND FRONT DOOR

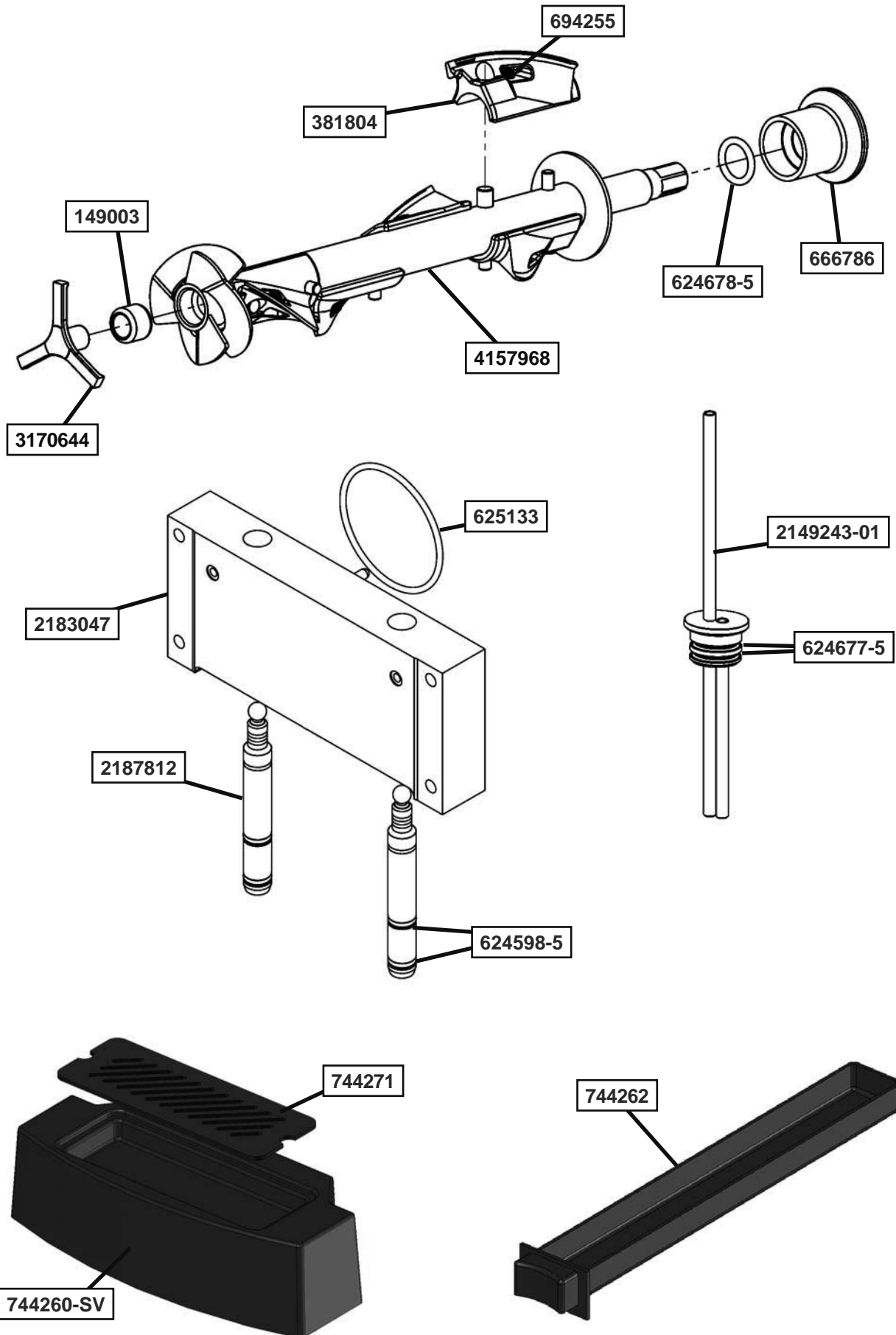

### 3.3 AUGER SHAFT AND FRONT DOOR (CONTINUED)

<b>Part</b>	<b>Description</b>	<b>Quantity</b>
149003	Bushing - Front Auger Support	2
232734	Cap - Rosette - Teardrop	3
314453	Cover - Hopper	2
381804	Auger Flight	8
482019	Knob - Front Door (Black)	4
624598-5	O-Ring - Outside Spigot - Black (5 Pack)	4
624677-5	O-Ring - Mix Inlet - Black (5 Pack)	4
624678-5	O-Ring - Rear Seal - Black (5 Pack)	2
625133	O-Ring - Front Door - Red	2
666786	Seal - Rear Auger - Black	2
694255	Spring - Auger Flight	8
744260-SV	Tray - Drip	1
744262	Tray - Drain (Black Plastic)	1
744271	Insert - Drip Tray (Black Plastic)	1
2149243-01	Mix Inlet Assembly - 3/16" Hole - Extended Length (2LA)	2
2177072	Extension - Spigot - 1.5"	-
2177073	Extension - Spigot - 2.5"	-
2177074	Extension - Spigot - 3.2"	-
2183047	Door w/Pins	1
2187812	Spigot Body - Outer	2
3170644	Support - Front Auger	2
4157968	Auger Shaft	2

### 3.4 BLENDER PARTS

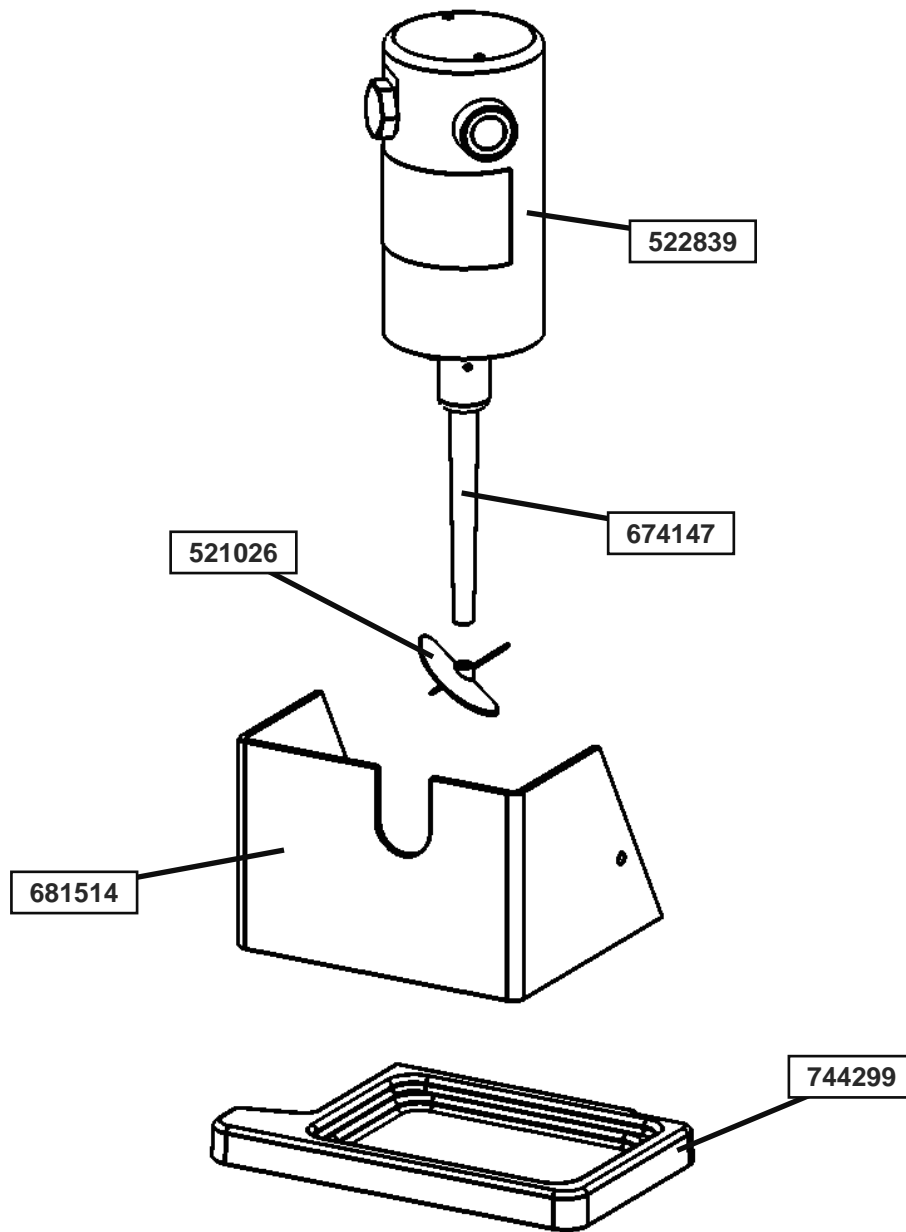

Part	Description	Quantity
521026	Blender Agitator	1
522839	Blender Motor	1
674147	Blender Shaft	1
681514	Swing Shield (Plastic)	1
744299	Tray - Drip (Blender)	1

### 3.5 SPIGOT CAM ASSEMBLY

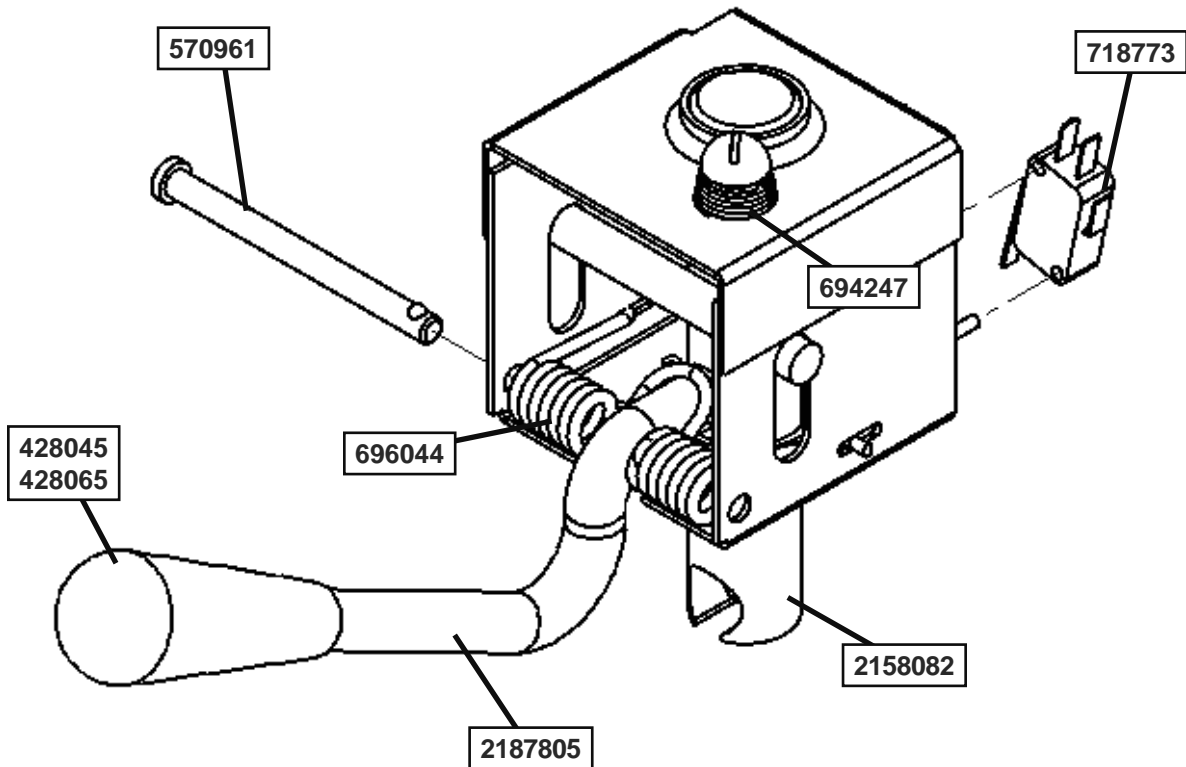

Part Number	Description	Quantity
428045	Knob - Spigot Handle (Black)	1
428065	Knob - Spigot Handle (Red) (SF144)	2
428081	Handle Assembly (Entire Assembly) - L.H. (27°)	1
428082	Handle Assembly (Entire Assembly) - R.H. (27°)	1
570961	Pin - Cotterless Clevis (Spigot Cam)	2
694247	Spring - Spigot Adjustment	2
696044	Spring - Torsion (Spigot Cam)	2
718773	Switch - Spigot Cam	2
2158082	Glide - Spigot Socket	2
2187805	Handle - Spigot (Metal Only)	2

### 3.6 STAINLESS STEEL PANELS

Part Number	Description	Quantity
232452	Plug - USB (R.H. Side Panel)	1
644734	Screw - Panel (Sides)	-
647653	Screw - Panel (Header, Back & Lower Front)	-
2203953	Panel - Header	1
2203962-SV	Panel - Right Side w/Insulation	1
2203964-SV	Panel - Rear w/Insulation (Water-Cooled)	1
3157964-SV	Panel - Left Side w/Insulation	1
3183224-SV	Panel - Rear w/Insulation (Air-Cooled) (R404A)	1
7183372-SV	Panel - Front Lower w/Insulation	1

### 3.7 REAR (AIR COOLED)

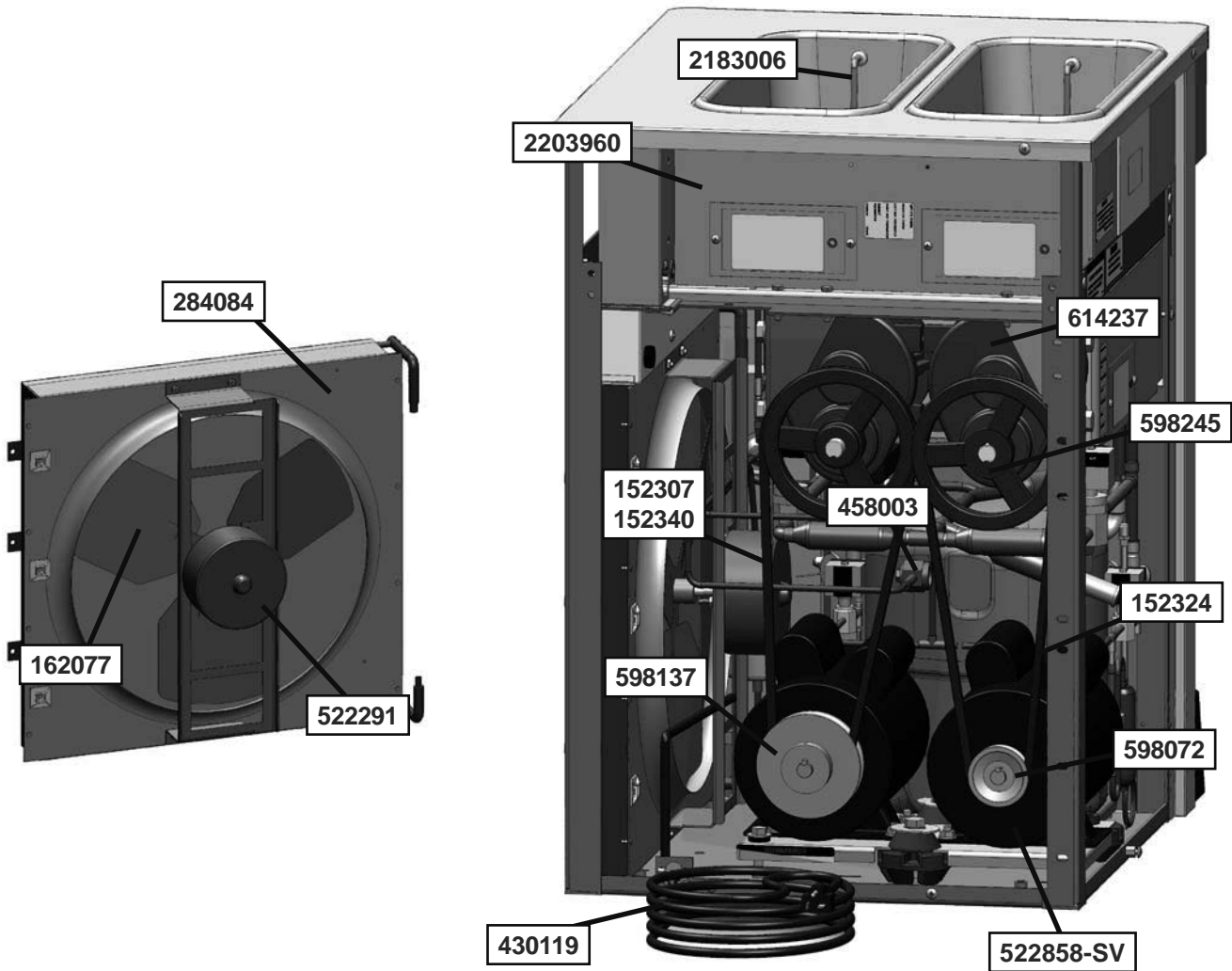

Part Number	Description	Quantity
152307	Belt - Gripnotch (AX38) (Each) (SF121)	1
152324	Belt - V (AX40 or 4L420) (Each) (60 Hz)	1
152340	Belt - Gripnotch (AX41) (Each) (SF144)	1
162077	Blade - Fan (Air-Cooled Condenser)	1
284084	Condenser (Air-Cooled) (R404A)	1
368140	Filter - Air (Condenser)	1
430119	Cord - Power	1
458003	Sight Glass	1
522291	Motor - Fan (50/60 Hz)	1
522858-SV	Motor - Drive (60 Hz)	2
598072	Pulley - Drive Motor (60 Hz)	1
598137	Pulley - Drive Motor (60 Hz) (SF144)	1
598245	Pulley - Speed Reducer	2
598540	Pulley - Drive Motor (60 Hz) (SF121)	1
614237	Speed Reducer	2
2183006	Probe Assembly - Hopper Liquid Level	2
2203960	Evaporator Assembly	1

### 3.8 LEFT SIDE

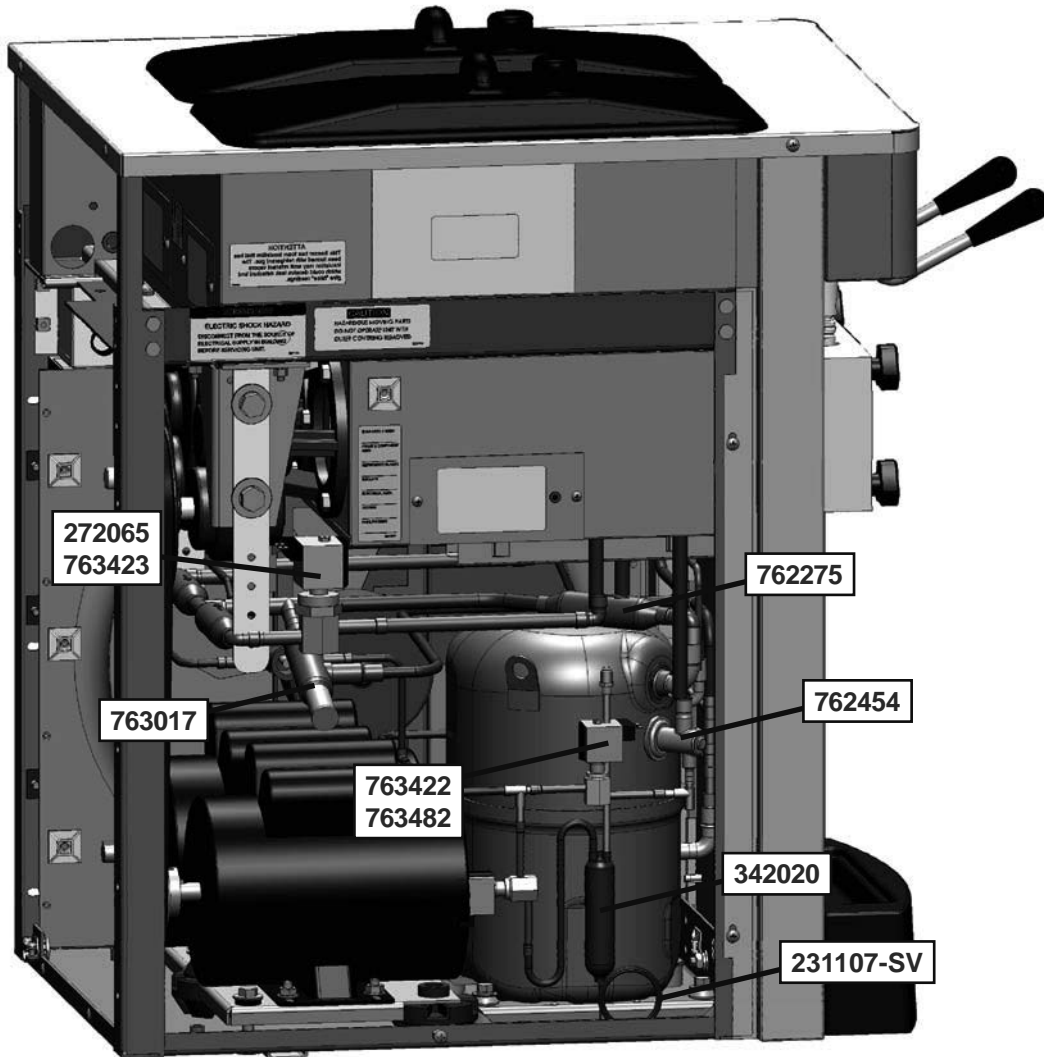

Part Number	Description	Quantity
231078	Capacitor - Run (#522858 Motor)	2
231095	Capacitor - Start (#522858 Motor)	2
231107-SV	Cap Tube & Drier Assembly	1
272065	Valve Coil - Solenoid (#763423 Valve)	2
342020	Drier (Hopper)	1
762275	Valve - Magna Check	3
762454	Valve - Expansion (TXV)	2
763017	Valve - Hot Gas Bypass	1
763422	Valve - Solenoid (1/4") (Liquid Line)	3
763423	Valve - Solenoid (1/2") (Suction Side)	2
763482	Valve Coil - Solenoid (#763422)	3

### 3.9 FRONT (WATER COOLED)

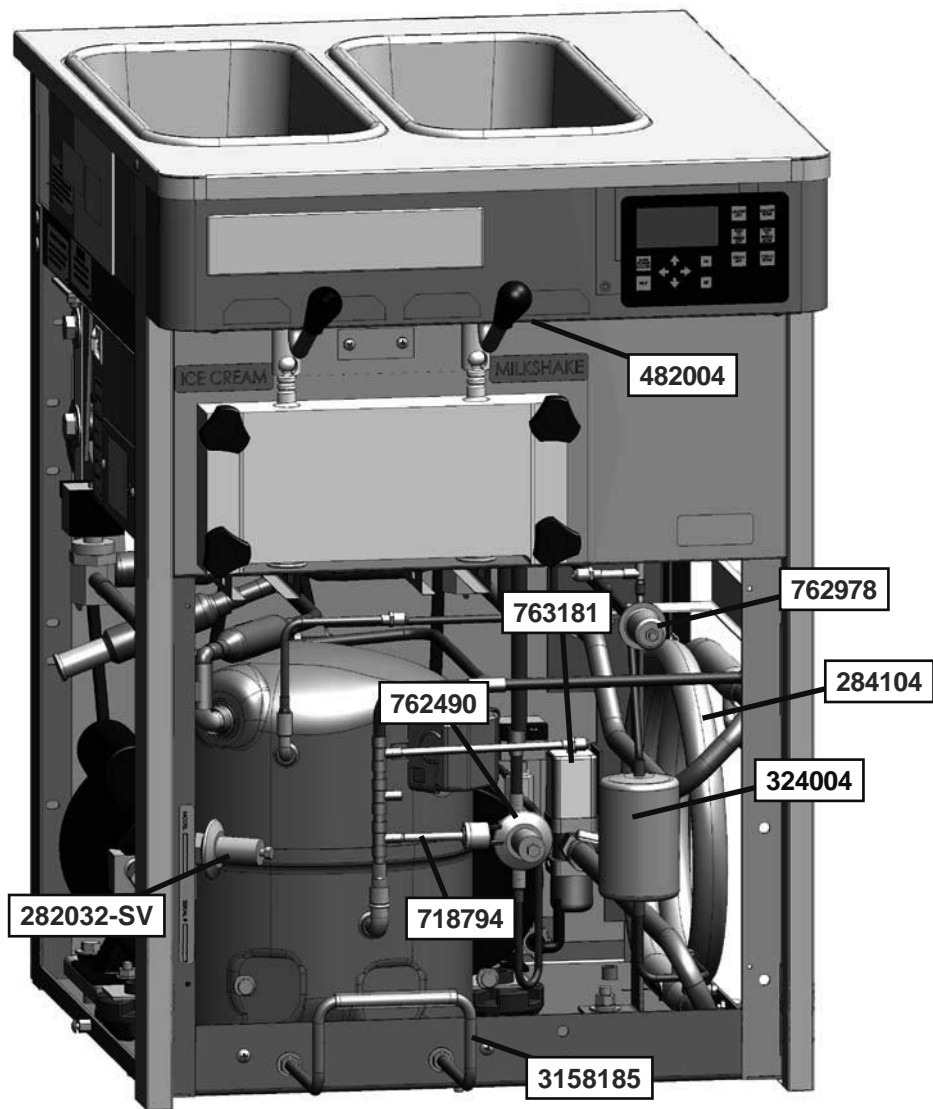

Part Number	Description	Quantity
282032-SV	Compressor - Copeland 1 PH - 60 Hz - R404A (No Capacitors)	1
284104	Condenser (Water-Cooled)	1
342004	Drier (Main)	1
482004	Knob (Spigot Adjustment)	3
718794	Switch - High Pressure Cutout	1
762490	Valve - Expansion (AXV)	2
762978	Valve - EPR	1
763181	Valve - Water	1
764385	Valve Kit - Water Valve Repair	-
3158185	Handle - Drain Tray Support	1



### 3.10 ELECTRICAL COMPONENTS

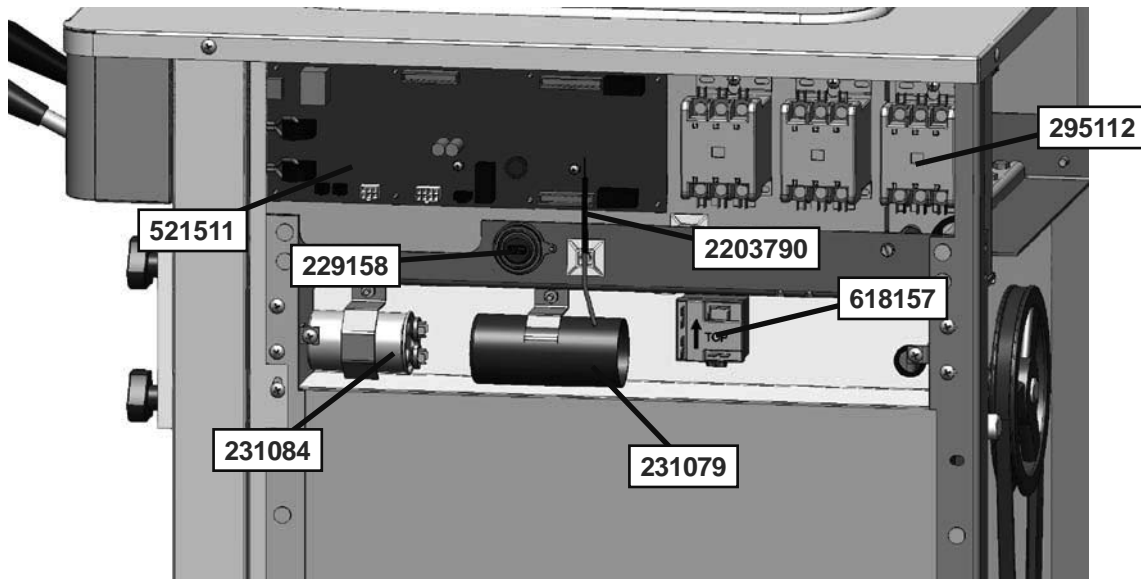
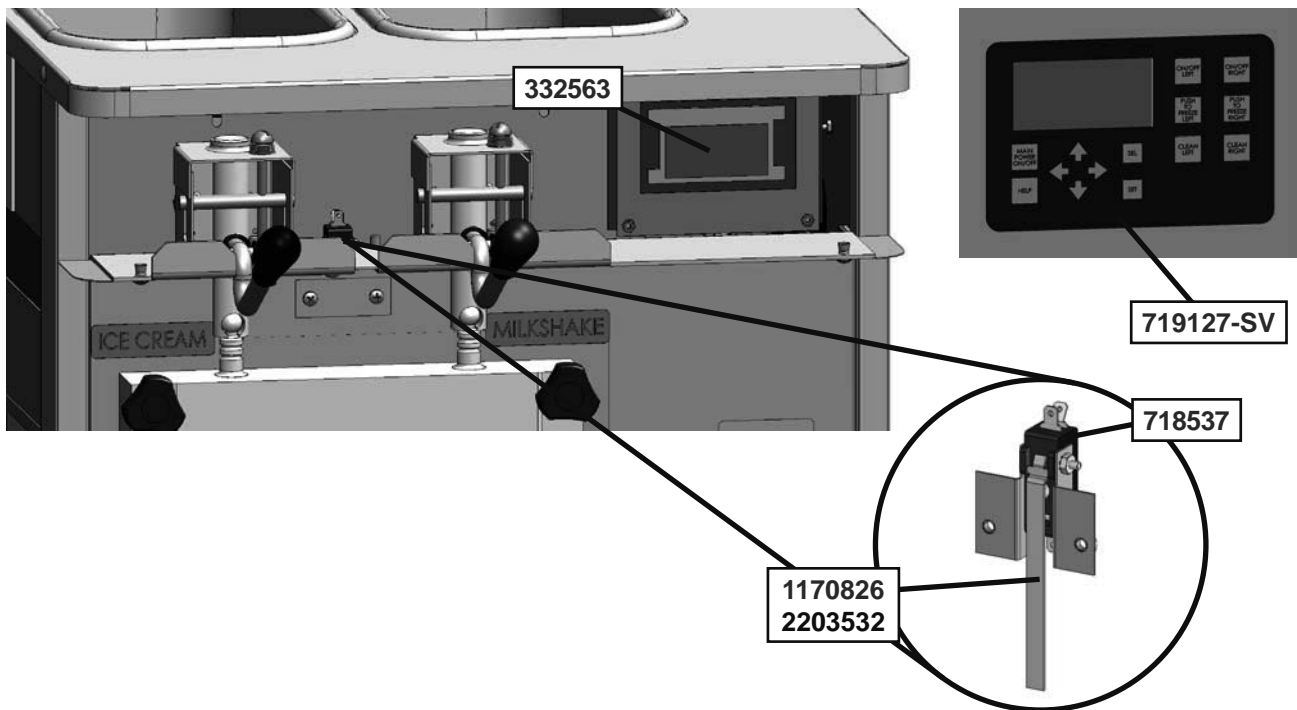

Part Number	Description	Quantity
229148	Cable - IntelliTec2 (Control Board to Display Board)	1
229158	USB Cable Extension	1
231079	Capacitor - Start (#282032 Compressor)	1
231084	Capacitor - Run (#282032 Compressor)	1
295112	Contactor - Compressor/Drive	3
332563	Board - Display Module (Display Only)	1
521511	Board - Program - IntelliTec2	1
618157	Relay - Start (#282032 Compressor)	1
719127-SV	Switch - Membrane Strip (Touchpad & Ribbon)	1
2203790	Sensor Probe Kit	-
718537	Switch - Limit (Door Interlock)	1
1170826	Switch Assembly - Door Interlock (Switch & Paddle)	1
2203532	Switch Assembly - Door Interlock (Switch, Paddle & Brackets)	1





**DOMESTIC WARRANTY  
(Including Mexico)  
SOFT SERVE / SHAKE EQUIPMENT**

1. **Scope:**  
PW Stoelting, L.L.C. (“Stoelting”) warrants to the first user (the “Buyer”) that the freezing cylinders, hoppers, compressors, drive motors, speed reducers, and augers of Stoelting soft serve / shake equipment will be free from defects in materials and workmanship under normal use and proper maintenance appearing within five (5) years, and that all other components of such equipment manufactured by Stoelting will be free from defects in material and workmanship under normal use and proper maintenance appearing within twelve (12) months after the date that such equipment is originally installed.
  
2. **Disclaimer of Other Warranties:**  

**THIS WARRANTY IS EXCLUSIVE; AND STOELTING HEREBY DISCLAIMS ANY IMPLIED WARRANTY OF MERCHANTABILITY OR FITNESS FOR PARTICULAR PURPOSE.**
  
3. **Remedies:**  
Stoelting’s sole obligations, and Buyer’s sole remedies, for any breach of this warranty shall be the repair or (at Stoelting’s option) replacement of the affected component at Stoelting’s plant in Kiel, Wisconsin, or (again, at Stoelting’s option) refund of the purchase price of the affected equipment, and, during the first twelve (12) months of the warranty period, deinstallation/reinstallation of the affected component from/into the equipment. Those obligations/remedies are subject to the conditions that Buyer (a) signs and returns to Stoelting, upon installation, the Start-Up and Training Checklist for the affected equipment, (b) gives Stoelting prompt written notice of any claimed breach of warranty within the applicable warranty period, and (c) delivers the affected equipment to Stoelting or its designated service location, in its original packaging/crating, also within that period. Buyer shall bear the cost and risk of shipping to and from Stoelting’s plant or designated service location.
  
4. **Exclusions and Limitations:**  
This warranty does not extend to parts, sometimes called “wear parts”, which are generally expected to deteriorate and to require replacement as equipment is used, including as examples but not intended to be limited to o-rings, auger flights, auger seals, auger support bushings, and drive belts. All such parts are sold

**AS IS.**

Further, Stoelting shall not be responsible to provide any remedy under this warranty with respect to any component that fails by reason of negligence, abnormal use, misuse or abuse, use with parts or equipment not manufactured or supplied by Stoelting, or damage in transit.

**THE REMEDIES SET FORTH IN THIS WARRANTY SHALL BE THE SOLE LIABILITY STOELTING AND THE EXCLUSIVE REMEDY OF BUYER WITH RESPECT TO EQUIPMENT SUPPLIED BY STOELTING; AND IN NO EVENT SHALL STOELTING BE LIABLE FOR ANY INCIDENTAL OR CONSEQUENTIAL DAMAGES, WHETHER FOR BREACH OF WARRANTY OR OTHER CONTRACT BREACH, NEGLIGENCE OR OTHER TORT, OR ON ANY STRICT LIABILITY THEORY.**