



Model 219 Mix Pump
OPERATORS MANUAL

Manual No. 1134067-4

Dec. 2005

This manual provides basic information about the machine. Instructions and suggestions are given covering its operation and care.

The illustrations and specifications are not binding in detail. We reserve the right to make changes to the machine without notice, and without incurring any obligation to modify or provide new parts for machines built prior to date of change.

DO NOT ATTEMPT to operate the machine until instructions and safety precautions in this manual are read completely and are thoroughly understood. If problems develop or questions arise in connection with installation, operation, or servicing of the machine, contact Stoelting.



stoeltingfoodservice.com

Stoelting Foodservice Equipment
502 Highway 67
Kiel, WI 53042-1600
U.S.A.

Main Tel: 800.558.5807
Fax: 920.894.7029

Customer Service: 888.429.5920
Fax: 800.545.0662
Email: foodservice@stoelting.com

© 2014 PW Stoelting, LLC

A Few Words About Safety

Safety Information

Read and understand the entire manual before operating or maintaining Stoelting equipment.

This manual provides the operator with information for the safe operation and maintenance of Stoelting equipment. As with any machine, there are hazards associated with their operation. For this reason safety is emphasized throughout the manual. To highlight specific safety information, the following safety definitions are provided to assist the reader.

The purpose of safety symbols is to attract your attention to possible dangers. The safety symbols, and their explanations, deserve your careful attention and understanding. The safety warnings do not by themselves eliminate any danger. The instructions or warnings they give are not substitutes for proper accident prevention measures.

If you need to replace a part, use genuine Stoelting parts with the correct part number or an equivalent part. We strongly recommend that you do not use replacement parts of inferior quality.



Safety Alert Symbol:

This symbol Indicates danger, warning or caution. Attention is required in order to avoid serious personal injury. The message that follows the symbol contains important information about safety.

Signal Word:

Signal words are distinctive words used throughout this manual that alert the reader to the existence and relative degree of a hazard.



The signal word "WARNING" indicates a potentially hazardous situation, which, if not avoided, may result in death or serious injury and equipment/property damage.



The signal word "CAUTION" indicates a potentially hazardous situation, which, if not avoided, may result in minor or moderate injury and equipment/property damage.

CAUTION

The signal word "CAUTION" not preceded by the safety alert symbol indicates a potentially hazardous situation, which, if not avoided, may result in equipment/property damage.

NOTE (or NOTICE)

The signal word "NOTICE" indicates information or procedures that relate directly or indirectly to the safety of personnel or equipment/property.

TABLE OF CONTENTS

Section	Description	Page
1	INTRODUCTION	1
1.1	Description	1
1.2	Specifications	1
2	INSTALLATION INSTRUCTIONS	3
2.1	Shipment and Transit (Remote Models)	3
2.2	National Sanitation Foundation Compliance Requirements (Remote Pump)	3
2.3	Installation (Remote Models)	4
2.4	Mix Pump Check Out	4
3	OPERATING INSTRUCTIONS	5
3.1	Safety Precautions	5
3.2	Pump Motor Switch	5
3.3	Sanitizing Procedures	6
3.4	Operation of Mix Pump	6
3.5	Cleaning	7
3.6	Disassembly of Mix Pump	8
3.7	Assembly of Mix Pump	10
3.8	“O” Ring Removal and Care	11
4	MAINTENANCE INSTRUCTIONS	13
4.1	Over-Run Adjustment	13
4.2	Pressure Control Switch	14
4.3	Preventive Maintenance	14
5	TROUBLESHOOTING	17
5.1	Pump Motor Does Not Run	17
5.2	Pump Operates But Cylinder Will Not Fill	17
5.3	Low Over-Run	17
6	REPLACEMENT PARTS INFORMATION	19
6.1	How To Order Replacement Parts	19
6.2	Parts List & Reference Drawings	19
6.3	Hopper Pump Final Assembly	20
6.4	Mix Pump Parts	22
6.5	Remote Pump Final Assembly	23
6.6	Pump Drive Assembly	25
 WARRANTY		

LIST OF ILLUSTRATIONS

Figure	Description	Page
1	Model 219-02 Mix Pump	1
2	Refrigerated Mix Transfer Line	3
3	Pump Controls	5
4	Pump Operation	7
5	Pump Assembly Removal	8
6	Manifold Disassembly	8
7	Pump Disassembly Step One	9
8	Pump Disassembly Step Two	9
9	Pump Disassembly Step Three	9
10	Pump Disassembly Step Four	9
11	Mix Pump Assembly	10
12	Removing "O" Rings	11
13	"O"- Ring Identification	12
14	Over-Run Adjustment	13
15	Pressure Gauge	14
16	Hopper Pump Final Assembly	20
17	Mix Pump Parts	21
18	Remote Pump Final Assembly	23
19	Pump Drive Assembly	24

SECTION 1 INTRODUCTION

1.1 DESCRIPTION

The Model 219 Stoelting® Mix Pump, is a high capacity pump that will pump 45 gallons of mix per hour. The pump is easy to clean, assemble, and operate. The pump features a built-in pressure relief valve to prevent excessive pressure build up in the freezer cylinder and mix lines. The same pump (with minor variations) is used for both hopper or remote model freezers. The instructions in this manual will apply to both the hopper and remote types.

1.2 SPECIFICATIONS

DIMENSIONS

Height	13" (33 cm)
Width	9" (22.86 cm)
Length	13-1/2" (34.29 cm)

WEIGHT

22 lbs. (9.98 kg)

ELECTRICAL (Remote)

115v, 60 Hz: @ .74 Amps
(220V, 50 Hz is available)

TUBING SIZE REQUIRED (Remote)

1/2" (1.27 cm) I.D.
3/4" (1.90 cm) I.D.



Figure 1. Model 219-02 Mix Pump

SECTION 2 INTRODUCTION

2.1 SHIPMENT AND TRUST (REMOTE MODELS)

The mix pump has been completely assembled, operated and inspected at the factory. Upon arrival at the final destination, the mix pump must be checked for any damage that may have occurred during transit.

The mix pump should arrive in satisfactory condition. **THE CARRIER IS RESPONSIBLE FOR ALL DAMAGE IN TRANSIT, WHETHER VISIBLE OR CONCEALED.** Do not pay the freight bill until you have checked the equipment. Have the carrier note any visible damage on the freight bill. If concealed damage and/or shortage is found later, advise the carrier inspector within 10 days and request inspection. The customer must place claim for damages and/or shortages in shipment with the carrier. **Stoelting, Inc. cannot make any claims against the carrier.**

2.2 NATIONAL SANITATION FOUNDATION COMPLIANCE REQ'S (REMOTE PUMP)

In order to comply with "National Sanitation Testing Laboratory, Inc." (NSF) code #6:

- A. This unit (**remote pump**) must be installed with a "NSF" listed refrigerated mix transfer line. The mix transfer line must be pitched to cooler, with no sags or low points, to allow complete drainage. (See fig. 2.)
- B. The product at the mix pump and in transfer line must be maintained below 45°F (7.22°C)

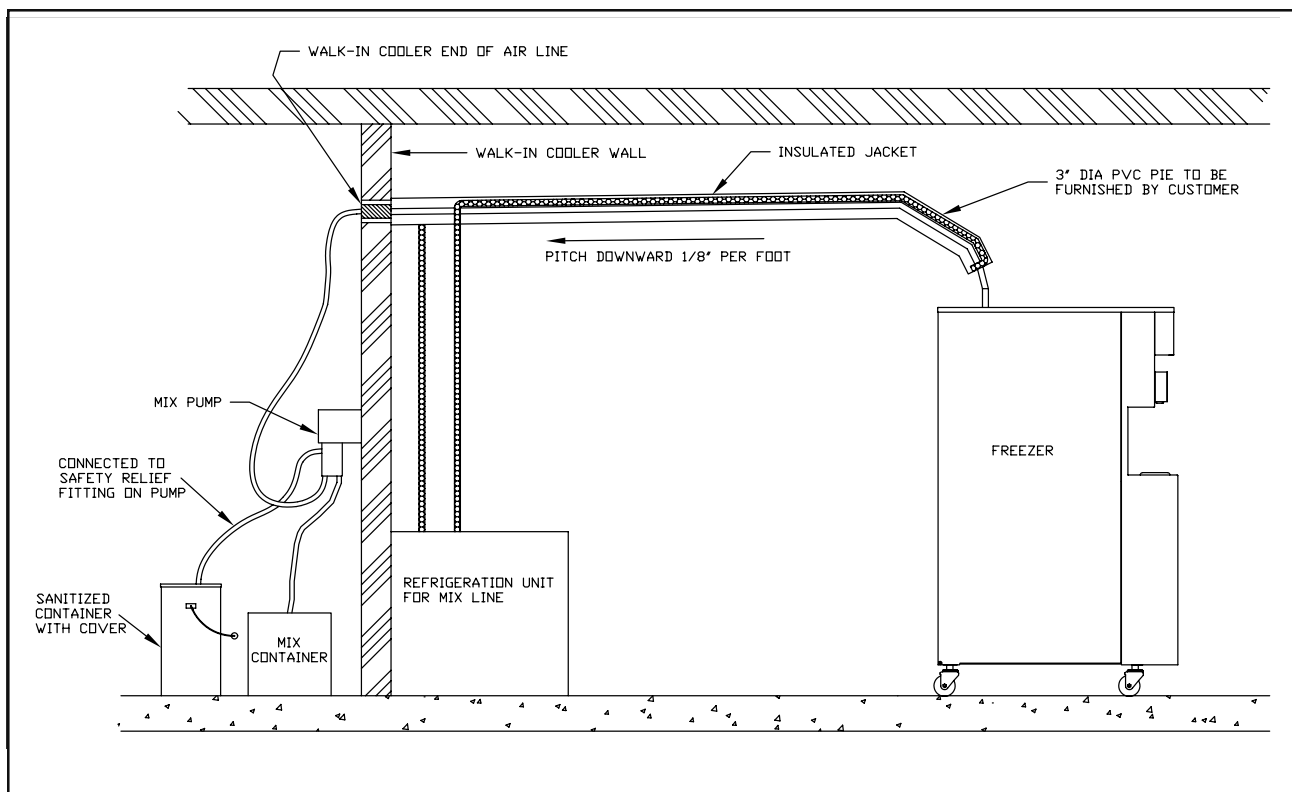

Figure 2. Refrigerated Mix Transfer Line

2.3 INSTALLATION

Typical Remote Pump Installation

The **hopper** mix pump is completely installed on the freezer. The **remote** mix pump is designed for mounting in a walk-in cooler. Select a location that is close to the soft serve freezer and a grounded 115 volt (220 volt if 50 hertz) receptacle. The mix pump should not be located near heavy traffic or in a congested area. Refer to Figure 2 and the following steps:

REMOTE MODELS INSTALLATION

- A. Install the mix pump in an upright position on the wall. Allow clearance for a mix can under pump. Mount by bolting bracket to wall using 1/4 inch (64cm) diameter lag bolts of sufficient length to hold securely.
- B. Connect 5/8 inch (1.60 cm) I.D. plastic food grade tubing between pump cylinder (inlet) and mix container.
- C. Connect 1/2 inch (1.27 cm) plastic food grade tubing between pump body mix transfer tube (outlet) and refrigerated mix transfer line. Secure with No. 26 hose clamp or equivalent.
- D. Connect 1/2 inch (1.27 cm) plastic food grade tubing between safety relief fitting to a separate pail or shot can.

NOTE

This line allows mix to escape if the system pressure should exceed 30 P.S.I.

- E. Plug mix pump into a 115 volt grounded receptacle. (Customer must provide plug for 220 volt, 50 hertz remote pump.)

WARNING

TO MINIMIZE SHOCK HAZARD, THE **REMOTE** MIX PUMP MUST BE PLUGGED INTO A PROPERLY GROUNDED ELECTRICAL RECEPTACLE WITHOUT THE USE OF A GROUND ADAPTER PLUG.

2.4 MIX PUMP CHECK OUT

The mix pump has been thoroughly cleaned and properly lubricated at the factory. Before using, the mix pump should be disassembled. This is necessary to remove any foreign materials and to familiarize operators with the correct assembly procedures.

- A. The over-run adjustment is preset at the factory. If an adjustment becomes necessary, refer to Section 4.1.
- B. The pump pressure is preset at the factory. If an adjustment becomes necessary, refer to Section 4.2.
- C. On **remote** pumps, check for air leaks by placing the suction line into three gallons of cold water. Place the freezer switches in the OFF position. Close the spigot and freezer air vents. Place mix pump switch in the ON position and allow the system pressure to build up and pump to shut OFF automatically. Leave pump on for ten minutes. During this time do not open spigot or freezer air vents. If pump does not automatically start again during this period, the system is free of leaks. If the pump does start, there is a leak in the system. Locate leak by applying a liquid detergent or bubbles solution with a small brush to all tubing connections and "O"-ring seals. Correct as required.

SECTION 3 OPERATION INSTRUCTIONS

3.1 SAFETY PRECAUTIONS

Do not attempt to operate the mix pump until the safety precautions and operating instructions in the manual are read completely and thoroughly understood.

Take notice of all warning labels on the mix pump. The labels have been put there to help in maintaining a safe working environment. The labels are designed to withstand washing and cleaning. All labels must remain legible for the life of the mix pump. Labels should be checked periodically to be sure they have not been removed, painted over, rubbed off, and can be recognized as warning labels.

If replacement labels are needed, indicate the part number, type of label, location of label, and quantity required. Mail your name and address to:

STOELTING, LLC
ATTENTION: CPG Customer Service
P.O. Box 127
Kiel, Wisconsin 53042-0127

Labels will be furnished and mailed at no charge.

SAFE OPERATION IS NO ACCIDENT; Observe these rules:

- A. Know the mix pump- read and understand the Owner's Manual.
- B. Wear proper clothing - avoid loose fitting garments, and remove watches, rings or jewelry which could cause a serious accident.
- C. Maintain a clean work area – avoid tripping or slipping by cleaning up the area and keeping it clean.
- D. Stay alert at all times – know which switch, push button or control you are about to use and what effect it is going to have.
- E. Turn all switches to OFF prior to making any adjustments.

- F. Do not attempt to repair or perform maintenance on the mix pump until the main electrical power has been disconnected.
- G. Do not operate the mix pump if unusual or excessive noise or vibration occurs.

3.2 PUMP MOTOR SWITCH

The PUMP MOTOR switch (see Fig. 3) is located on the mix pump assembly. When the pump motor switch is placed in the ON position, the mix pump motor will be actuated to pump mix into the freezer cylinder. When the set pressure is reached, the mix pump will shut off automatically. When the pump motor switch is placed in the OFF position. The mix pump will be inoperative.

The mix pump motor is equipped with an overload push button reset switch (labeled "Drive Reset") that will "kick-out" when the motor is overloaded. Motor overloads can be caused by several things including improper assembly of the pump or worn parts causing binding, or electrical problems. Pressing the reset button will return the motor to normal operation if the overload condition is no longer present. If the pump assembly seems to move freely but the overload condition continues, contact a qualified service person.



Figure 3. Pump Controls

3.3 SANITIZING PROCEDURES

For sanitizing to be effective, it must be performed after the mix pump and freezer parts have been cleaned, and just prior to filling the hopper or storage container with mix. Sanitizing the night before is not effective.

To sanitize, refer to local sanitary regulations for applicable codes and recommended disinfecting products and procedures. The frequency of cleaning must comply with local health regulations. Use a solution containing 100 PPM of free available chlorine. Use "Stera-Sheen Green Label Sanitizer and Cleaner", or others in accordance with Health Inspection Requirements.

NOTE

Stoelting, Inc. has found that STERA-SHEEN GREEN LABEL SANITIZER AND CLEANER does an effective job of properly sanitizing and cleaning a soft serve freezer. We therefore include a sample with each new freezer. For further information read the directions on the packet. Other products may be effective.

CAUTION

PROLONGED CONTACT OF SANITIZER WITH FREEZER MAY CAUSE CORROSION OF STAINLESS STEEL PARTS.

In general, sanitizing may be conducted as follows:

- A. Prepare three gallons (11 liters) of sanitizing solution following manufacturer's instructions, and pour into hopper (**hopper models**) or place pump suction (inlet) line into solution (**remote models**).
- B. Place the mix pump switch in the ON position. Allow freezer to fill until pump stops.
- C. Check for leaks when the freezer barrel is first pressurized with sanitizing solution.
- D. Clean the following parts using a sanitized soft bristle brush or equivalent, dipped in sanitizing solution. On **remote models**, clean exterior of pump and sides of mix container. On **hopper models**, clean exterior of pump, sides and under cover of hopper.

- E. Place the freezer in the CLEAN mode (no refrigeration).
- F. After five minutes, open spigot to expel sanitizing solution.
- G. Close the spigot and place the mix pump and freezer switches in the OFF position.

The mix pump, connecting hoses and freezer are clean, sanitized and ready for adding mix.

NOTE

Do not use brushes to clean hoses. Brushes can cause scratches to interior of mix hose resulting in areas that will harbor bacteria.

3.4 OPERATION OF MIX PUMP

This section describes the operation of the mix pump. (See Fig. 4)

NOTE

The safety guard must be in place before the mix pump will operate.

- A. Sanitize just prior to use according to instructions in Section 3.3.
- B. Refer to freezer instruction manual for the operation of the freezer.
- C. Mix Operation:
 1. Mix will enter pump thru mix inlet valve (A) on position UP stroke.
 2. On piston DOWN stroke, mix inlet (A) is forced shut and mix is moved out thru mix outlet valve (B) into the freezing chamber.
- D. Air Operation:
 1. Air enters pump thru air inlet check valve (C) on piston DOWN stroke.

2. On piston UP stroke, air inlet check valve (C) is forced shut and air is moved out of air outlet valve (D) into mix transfer tube bottom (F) and into the freezing chamber.

E. Relief Valve Operation:

1. The relief valve (E) opens and releases pressure if the pressure switch fails to shut off the pump motor.

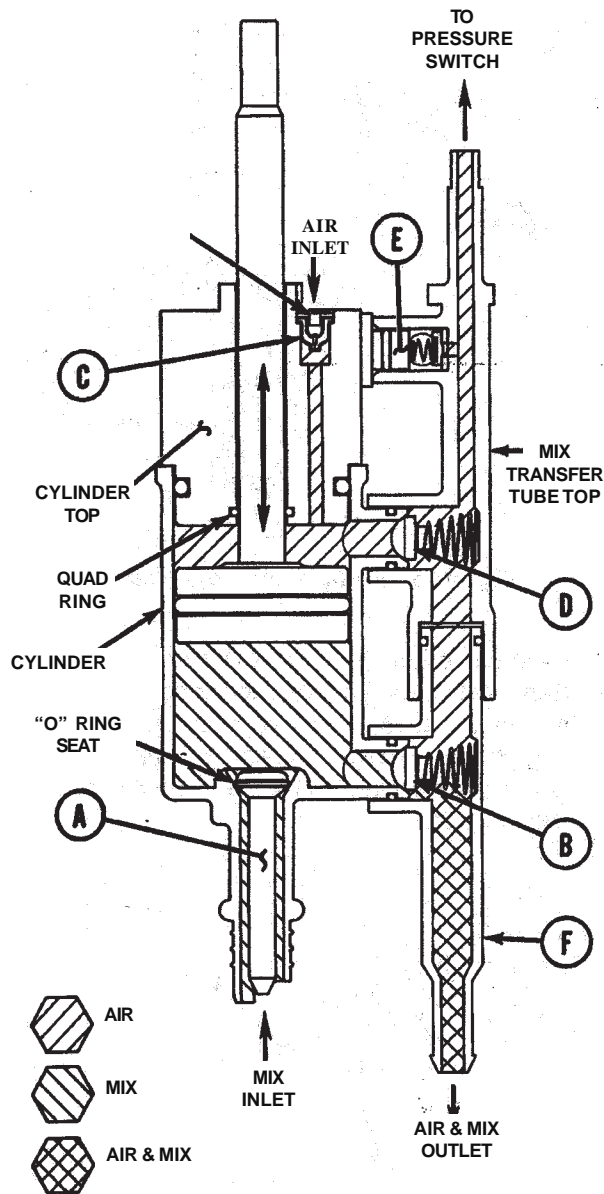

Figure 4. Pump Operation

3.5 CLEANING

The mix pump must be cleaned when changing mix or whenever the freezer is shut off for an extended period, such as overnight or on nonbusiness days. For sanitary reasons, mix must not be allowed to remain in the freezer lines or mix pump when the freezer is not in operation.

NOTE

Refer to the freezer manual for freezer cleaning procedures.

- A. On **remote models**, remove suction tubing from the mix container. Draw off all or most of the mix remaining in the freezer barrel.
- B. Pump 3 gallons (11 liters) of cold potable water thru freezer until water at spigot is free of mix.
- C. Pump 3 gallons (11 liters) of **warm** detergent solution water thru freezer. The use of soft water is recommended along with dishwashing detergents such as "Joy", "Dawn", or equivalent.
- D. Place mix pump switch in OFF position.
- E. Disassemble pump parts. (See Section 3.6.) Then place all parts in warm, mild detergent water and wash thoroughly using brushes provided. Again, the use of soft water is recommended along with dishwashing detergents such as "Joy", "Dawn", or equivalent. Rinse all parts with clean **hot** water.

NOTE

If the mix lines or air lines are difficult to remove, soften with hot water or a rag soaked in hot water. Hose connections may be sprayed with Haynes Sanitary Lubricant for ease of removal.

- F. Use a sanitizing solution of 100 parts per million to sanitize the parts before assembly. Use "Stera-Sheen Green Label Sanitizer and Cleaner", or others in accordance with Health Inspection Requirements.
- G. Place all parts in the sanitizing solution for 5 minutes, then remove and let air dry.

CLEANING MIX LINES

The mix lines must be cleaned and sanitized whenever changing mix or whenever the freezer is off for an extended period of time—such as overnight, or nonbusiness days. The mix lines are sufficiently cleaned and sanitized when cleaning and sanitizing the pump and freezer as an assembly.

Once every 2 weeks, if required, perform the following steps:

- A. Mix 2 gallons of milkstone remover solution according to the directions on the container and pump through the mix line.
- B. Cut a piece of sponge slightly larger than the inside diameter of the mix line. Place the sponge inside the mix line and force through with tap water pressure. A garden hose repair end clamped to the mix line works well for this purpose.

3.6 DISASSEMBLY OF MIX PUMP

Refer to your Owner's Manual for detailed instructions on proper freezer operation.

WARNING

THE MIX PUMP SWITCH MUST BE IN THE OFF POSITION WHEN SERVICING OR CLEANING PUMP.

- A. Drain freezer according to freezer owner's manual.

CAUTION

NEVER DISCONNECT HOSES FROM FREEZER OR PUMP WITHOUT FIRST OPENING SPIGOT TO RELIEVE PRESSURE.

- B. **REMOTE MODEL:** Loosen hose clamps and remove tubing from pressure relief valve. Remove suction tubing from pump and mix bag. Remove discharge tubing from bottom of pump. Remove drive pin by pulling straight out.

HOPPER MODEL: Remove liquid level indicator. Remove the two wing nuts from the pressure switch manifold retainer and remove the manifold (both models).

- C. Remove large hand nut (1), washers (2) and rear hopper cover (3). (See Fig. 5)

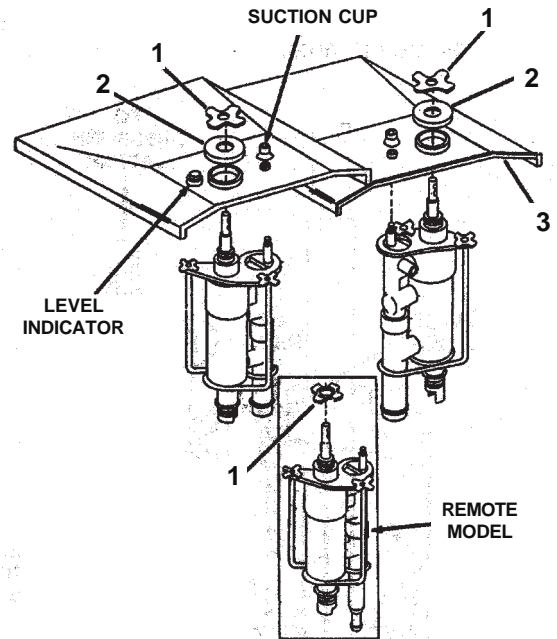

Figure 5. Pump Assembly Removal

- D. Remove quick connect (4) from manifold (5). Remove two wing nuts (6), locking plate washer (7), and manifold (5). Remove manifold connector O-ring (8) from manifold (5), and manifold "O"-ring (9). Loosen hose clamp (10) and remove hose (11). (See Fig. 6)
- E. Remove two small hand nut(s) (12) and top lock plate (13) from clamp rod (14). (See Fig. 7)

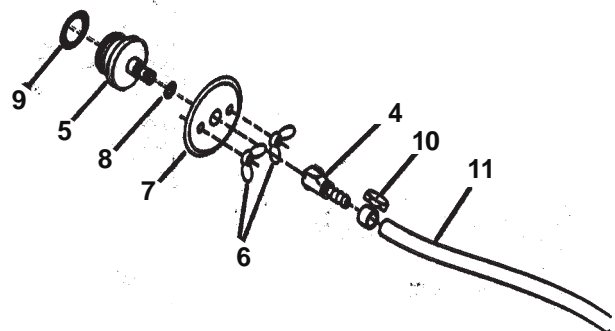

Figure 6. Manifold Disassembly

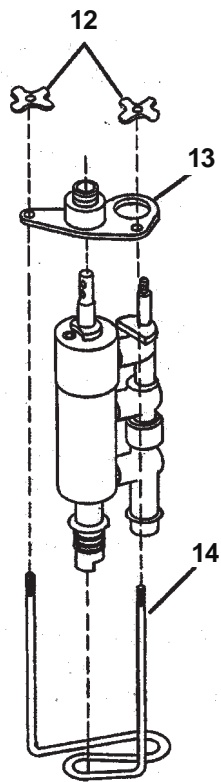

Figure 7. Pump Disassembly Step One
 F. Separate mix transfer tube (15) from cylinder (16).
 (See Fig. 8)

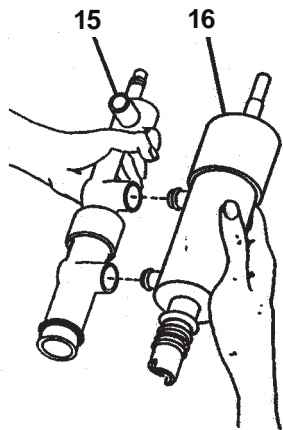

Figure 8. Pump Disassembly Step Two

- G. Remove safety valve retainer (17), valve retainer "O"-ring (18), spring (19) and safety valve (20). Remove two air mix outlet valves (21) and two air mix outlet springs (22). Remove mix transfer tube "O"-ring (23). Separate air transfer tube top (24) from mix transfer tube bottom (25). Remove cylinder "O"-ring (26).
 (See Fig. 9)

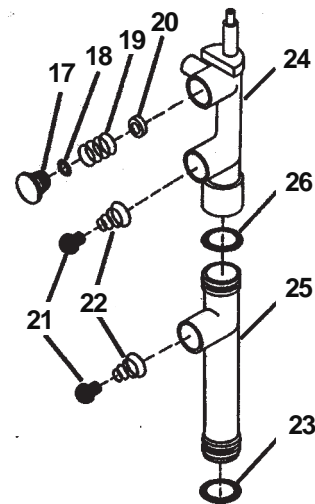

Figure 9. Pump Disassembly Step Three

- H. Remove two cylinder "O"-rings (27) from cylinder body (28). Remove air inlet retainer (29) and air inlet check valve (30) from cylinder top (31). Remove cylinder top (31) from cylinder body (28), remove "O"-ring (32) and piston quad ring (33) from cylinder top (31). Remove piston shaft (34), and "O"-ring (35) from piston shaft (34). Remove mix inlet valve (36) from cylinder body (28), and remove "O"-ring (37) from mix inlet valve (36). (See Fig. 10)

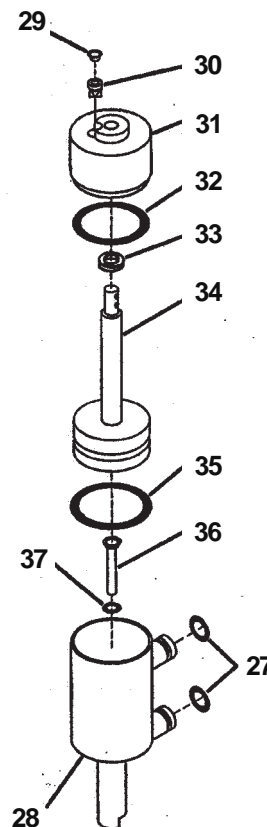

Figure 10. Pump Disassembly Step Four

3.7 ASSEMBLY OF MIX PUMP

CAUTION

DO NOT FORCE PARTS, THEY FIT TOGETHER EASILY WHEN PROPERLY INSTALLED.

Haynes sanitary lubricant or liquid equivalent must be used to lubricate all "O"-rings, piston shaft and bore of cylinder body.

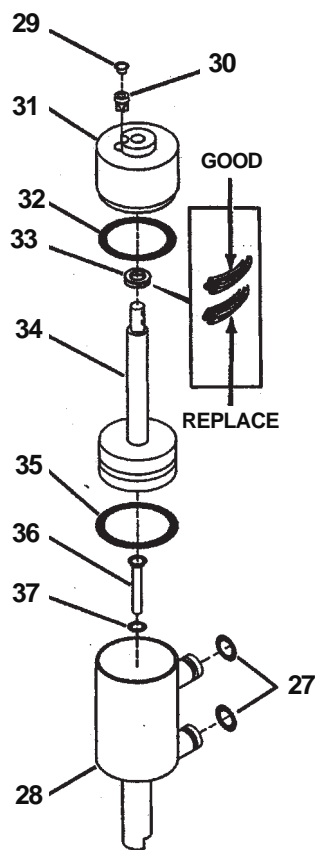

Figure 11. Mix Pump Assembly

- A. Place manifold "O"-ring (9) onto manifold (5) and lubricate lightly. Place manifolds connector "O"-ring (8) onto manifold (5) and lubricate. Place manifold (5) into pressure switch. Position locking plate washer (7) and secure with two wing nuts (6) finger tight. Connect tubing (11) to quick connect (4) and tighten hose clamp (10) finger tight. Connect quick connect (4) to manifold (5). (See Fig. 6)
- B. Install air inlet check valve (30) into cylinder top (31). Do not lubricate. Install air inlet retainer (29) into air inlet valve. Push into place. Check quad ring (33) for excessive wear and replace if necessary. Spray a thin film of lubricant in bottom of cylinder top (31).

NOTE

Quad ring must not be twisted.

Install quad ring (33) and rotate one full turn to improve sealing. Place "O"-ring (35) onto piston shaft (34) and "O"-ring (32) onto cylinder top (31). Spray a thin film of lubricant onto the two "O"-rings, piston shaft and cylinder walls. Position cylinder top (31) over piston shaft (34). Place "O"-ring (37) onto mix inlet valve (36) and insert inlet valve (36) into cylinder (28). Assemble cylinder top (31) and piston (34) into cylinder (28) and push piston fully down.

- C. Place "O"-ring (26) onto mix transfer tube bottom (25) and lubricate. Place mix transfer tube bottom (25) into air transfer tube top (24). (See Fig. 9)

On hopper models: place mix transfer tube "O"-ring (23) onto bottom of mix transfer tube (25) and lubricate lightly. Position small end of two air/mix outlet springs (22) onto two air/mix outlet valves (21) and insert into mix transfer tube. Place valve retainer "O"-ring (18) onto valve retainer (17). Insert safety valve (20), spring (19) and valve retainer (17) into top hole of mix transfer tube. (See Fig. 9)

- D. Holding valve retainer firmly in place with thumb and forefingers, join mix transfer tube (15) to pump cylinder (16) as shown. (See Fig. 8)

- E. Place top lock plate (13) and clamp rod (14) over end of pump cylinder and mix transfer tube. Secure with two hand nuts (12) and finger tighten.

(See Fig. 7)

- F. **On hopper models:** position hopper rear cover over assembled pump body. Assemble washer (2) and large hand nut (1) onto top lock plate (3). Do not tighten at this time. Place pump body with hopper cover into hopper. Tilt pump forward and push toward rear of hopper until discharge end of pump body engages hopper outlet hole. Guide hopper rear cover under pump drive bracket at the same time. Install suction cup over pressure tube and connect tubing and tighten hose clamp finger tight. Assemble liquid level indicator by first installing "O"-ring into indicator cover and lubricating lightly. Slide red float into adapter and install indicator cover onto adapter. Place indicator into rear hopper cover. (See Fig. 5)

On hopper and remote models: place pump body under drive bracket. Slip top lock plate threaded shaft into slot in pump drive bracket. Align top hole in piston shaft with holes in drive clevis. Use drive pin to aid in lifting and aligning piston shaft. When top hole in piston shaft is aligned with hole in piston drive, insert drive pin. Secure large hand nut (1) as tight as possible with fingers. Install safety guard over pump drive and secure with two black knobs. Interlock hopper front cover with hopper rear cover. (See Fig. 5)

NOTE

The safety guard must be in place before mix pump will operate.

On remote models: install tubing onto suction and discharge connections on bottom of pump and pump body. Tighten hose clamp. For ease of removal, use

lubricant on hose ends prior to installing tubing. Install tubing onto pressure relief valve connection.

NOTE

IMPORTANT- Refer to paragraph 3.3 Sanitizing Procedure prior to filling with mix.

3.8 O-RING REMOVAL AND CARE

Worn or damaged "O"-and "Quad" ring seals must be replaced to ensure proper freezer operation. To prevent undue damage to these seals, at least once a week be sure to apply lubricant where required and avoid twisting "O"-rings during assembly. Worn or damaged "O"-rings or "O"-rings which are twisted after assembly will cause air and/or mix leakage. Leaks will result in a low over-run product.

To remove "O"-rings from parts for cleaning or servicing, follow the steps below:

- A. Remove all sanitary lubricant from "O"-ring using a clean paper towel.

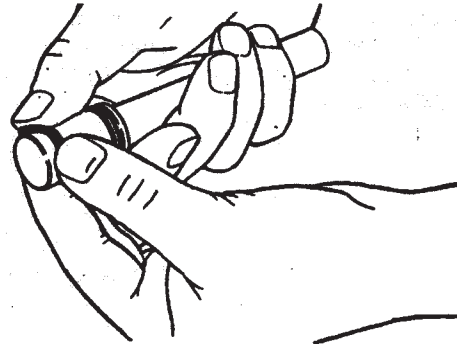

Figure 12. Removing "O"-Rings

- B. Remove "O"-ring by squeezing upward as shown in Figure 12. When a loop is formed, roll the "O"-ring out of the "O"-ring groove.

CAUTION

DO NOT USE ANY TYPE OF SHARP OBJECT TO REMOVE "O"-RING.

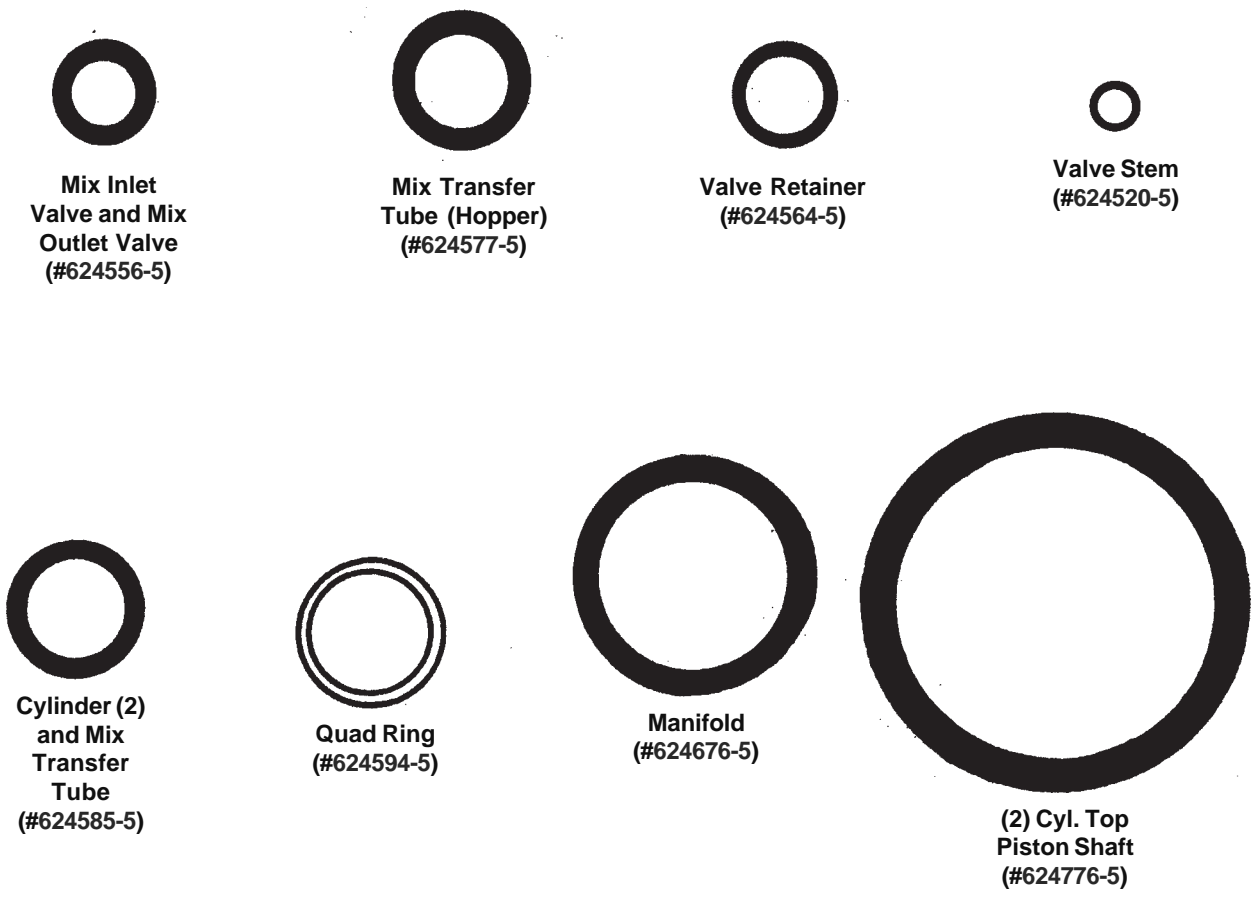

Figure 13. "O"-Ring Identification (Actual Size)

SECTION 4 MAINTENANCE INSTRUCTIONS

4.1 OVER-RUN ADJUSTMENT

The product when served is a combination of air and mix. Over-run is a measure of the amount of air blended into the mix.

Over-run can be expressed in terms of the amount of weight loss for a given volume. For example, if a pint of liquid mix weighs 18 ounces and a pint of frozen product with air added weighs 12 ounces, the over-run is said to be 50 percent ($18\text{oz.} - 12\text{oz.} = 6\text{oz.}$, $(6 \div 12) \times 100 = 50\%$).

The over-run can be checked by placing a one pint container on an ice cream scale and zeroing out the scale. Then fill a one pint container with frozen product. The container should be filled over the top and leveled with a straightedge. The product should not contain any air pockets. When weighed on an ice cream scale, one pint of product should weigh 12 to 13 ounces.

The mix pump has been preset at the factory to produce a product with approximately 40 percent over-run. Because of differences in mix formulation, temperatures, and barometric pressure, this figure may vary. A product with the proper amount of over-run is firm and dispenses at a smooth even rate. A product in which the over-run is too low, is yellow, heavy, icy, hard or stiff, and dispenses at a slow or pulsating rate. A product which has small air pockets and dispenses smoothly, but with an occasional popping as the product leaves the spigot, has the over-run set too high. It will be necessary for approximately two gallons of mix to be pumped thru the freezer before changes in the product are noticeable due to adjustments in over-run.

Over-run is controlled by the relative position of the piston stroke within the pump cylinder. Raising the stroke within the cylinder will increase over-run. Conversely, lowering the stroke will decrease over-run.

To adjust the mix pump for a **higher over-run**, refer to Figure 14, and follow the adjustment procedures below:

CAUTION

THE MIX PUMP SWITCH MUST BE IN THE OFF POSITION WHEN SERVICING OR CLEANING PUMP.

- A. Remove two knobs and safety guard covering drive mechanism.
- B. The position of the stroke is adjusted by loosening the jam nut (B) above the drive clevis (C) and then turning the drive clevis up for a higher over-run.

CAUTION

THE DRIVE MECHANISM MUST BE POSITIONED AT THE TOP OF THE STROKE. THE TOP OF THE STROKE IS WHEN THE CAM ROLLER IS IN ITS HIGHEST POSITION. PUMP DAMAGE WOULD RESULT IF PISTON WERE TO CONTACT CYLINDER TOP BEFORE REACHING TOP OF STROKE. A 180 DEGREE TURN OF THE CLEVIS IS APPROXIMATELY AN OVER-RUN OF 2-1/2%.

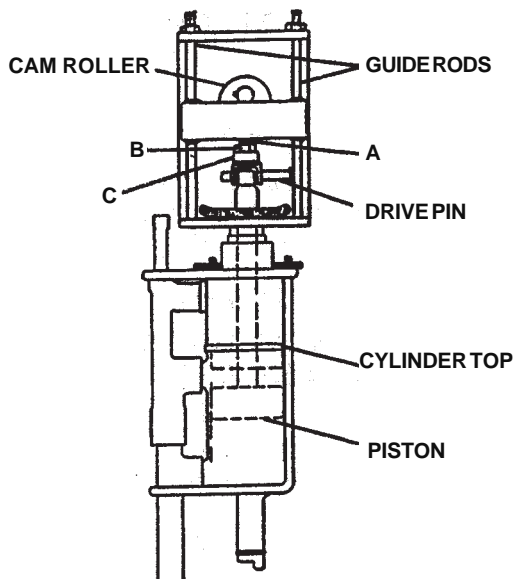

Figure 14. Over-Run Adjustment

To adjust the mix pump for a **lower over-run**, refer to Figure 14, and follow the adjustment procedures below:

CAUTION

THE MIX PUMP SWITCH MUST BE IN THE OFF POSITION WHEN SERVICING OR CLEANING PUMP.

- A. Remove two knobs and safety guard covering drive mechanism.

CAUTION

THE DRIVE MECHANISM MUST BE POSITIONED AT THE BOTTOM OF THE STROKE.

- B. The position of the stroke is adjusted by loosening the jam nut (B) above the drive clevis (C), and then turning the drive clevis down for a lower over-run. The drive clevis and yoke stud (A) must be engaged by a minimum of four full threads.

4.2 PRESSURE CONTROL SWITCH

The pressure control switch control the pressure at which the mix pump cuts in or out. This switch can not be adjusted.

NOTE

Pressure gauge manifold accessory kit (Part No. 1156527) is available to check pressures.

CAUTION

DISCONNECT ELECTRICAL SUPPLY TO MIX PUMP BEFORE SERVICING.

- A. Install the pressure gauge kit into the pressure switch. Figure 15.



Figure 15. Pressure Gauge

- B. Connect electrical input power to the mix pump.
- C. The pressure check must be made with either water or mix in the freezer cylinder.
- D. Place the mix pump switch in the ON position and check pressures.

4.3 PREVENTIVE MAINTENANCE

It is recommended that a preventive maintenance schedule be followed to keep the mix pump clean and operating properly. The following steps are suggested as a preventive maintenance guide.

WARNING

NEVER ATTEMPT TO REPAIR OR PERFORM MAINTENANCE ON MIX PUMP UNTIL ALL MAIN ELECTRICAL POWER HAS BEEN DISCONNECTED.

The United States Department of Agriculture and the Food and Drug Administration require that lubricants used on food processing equipment be certified for this use. Use lubricants only in accordance with the manufacturer's instructions.

A. DAILY CHECK

1. Check for any unusual noise or condition and repair immediately.

B. WEEKLY CHECK

CAUTION

THE MIX PUMP SWITCH MUST BE IN THE OFF POSITION WHEN SERVICING OR CLEANING PUMP.

1. Clean and lubricate with liquid sanitary lubricant or equivalent, the two guide rods on the pump motor. Apply lubricant to rods with fingers to eliminate spray accumulation on other components. Remove the two knobs and safety guard for access.

C. FOUR MONTH CHECK

1. Every four months, or as required, replace quad ring in mix pump if worn, or low over-run will result.

SECTION 5 TROUBLESHOOTING

WARNING

NEVER ATTEMPT TO REPAIR OR PERFORM MAINTENANCE ON MIX PUMP UNTIL THE MAIN ELECTRICAL POWER HAS BEEN DISCONNECTED.

5.1 PUMP MOTOR DOES NOT RUN

Cause	Correction
Plastic guard is not in place.....	Install plastic guard.
Power to pump is off.....	Supply power to pump.
Low voltage.....	Check for low voltage.
Pump motor overloaded.....	Press "Drive Reset" button.
Guide rods on pump are sticky.....	Clean and lubricate. (Refer to Section 4.3B)
Frozen mix particles in liquid mix.....	Remove frozen mix.
Pressure switch on pump is defective.....	Check continuity of pressure switch. Replace.
Defective starter relay (motor buzzing).....	Replace starter relay. (On older models.)
Defective motor.....	Check motor amperage draw. Replace motor.
Defective toggle switch.....	Check continuity, repair or replace.
Defective safety switch.....	Check continuity, repair or replace.
Broken wire or loose connection.....	Locate and replace or repair.

5.2 PUMP OPERATES BUT CYLINDER WILL NOT FILL

Cause	Correction
Frozen mix particles in liquid mix.....	Thaw, remove frozen mix.
Foreign object blocking operation or pump.....	Disassemble pump and clear blockage.
Mix inlet valve is stuck or "O"-ring defective.....	Disassemble pump and check mix inlet valve and "O"-ring.
Mix outlet valve "O"-ring is defective.....	Disassemble pump and check "O"-ring.

5.3 LOW OVER-RUN

Cause	Correction
Foreign object blocking operation of pump.....	Disassemble pump and clear blockage.
Air inlet check valve or retainer stuck or restricting air flow.....	Disassemble pump and check air inlet check valve and retainer.
Air outlet valve is stuck or "O"-ring is defective.....	Disassemble pump, check air outlet valve and "O"-ring.
Pump quad ring is worn out.....	Replace quad ring.

In the event the above Troubleshooting Guide does not help to correct the problem, the local dealer, distributor or the factory Service Department should be contacted.

SECTION 6 REPLACEMENT PARTS INFORMATION
--

6.1 HOW TO ORDER REPLACEMENT PARTS

To assure the receipt of the proper replacement parts, supply your dealer, distributor or the company with the following information:

- A. Model number of equipment.
- B. Serial number of Model. (Stamped on nameplate.)
- C. Part number, part name, and quantity needed. Many part names and numbers are listed in this manual.

NOTE

Minimum is \$50.00.

6.2 PARTS LIST & REFERENCE DRAWINGS

The following lists and drawings will aid the user when ordering parts or servicing the mix pump. The parts listed apply to both the hopper or remote pumps unless noted otherwise.

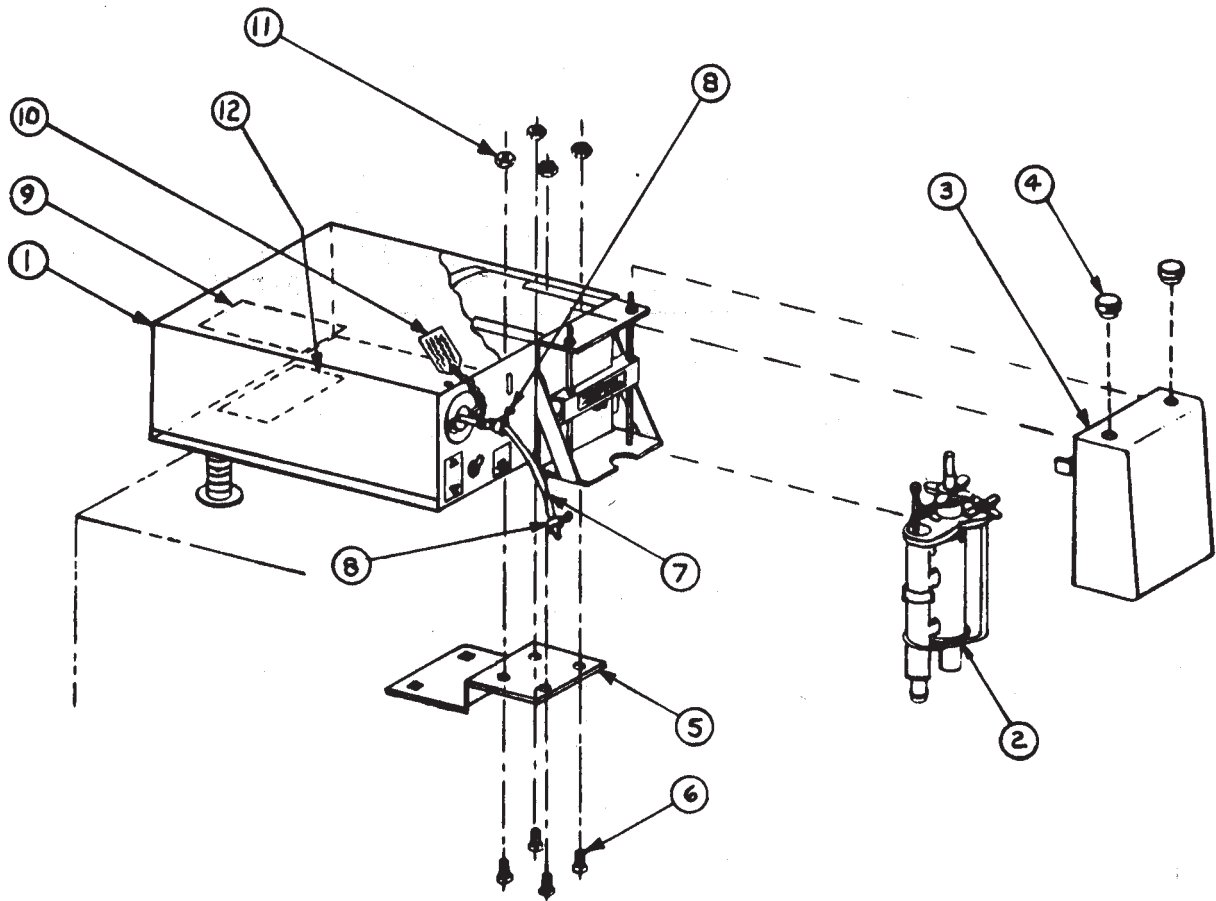

Figure 16. Hopper Pump Final Assembly

6.3. HOPPER PUMP FINAL ASSEMBLY

Ref. No.	Part No.	Description	Qty.
1	4154611	Pump Drive	1
2	3143083	Pump Body	1
3	3147873	Safety Guard	1
4	482004	Black Knobs	2
5	3122813	Motor Mounting Plate	1
6	644106	Hex Cap Screw (1/4-20)	4
7	756190	Tubing	1
8	264235	Hose Clamp	2
9	324197	Wiring Diagram Decal	1
10	723530	Pressure Instruction Tag	1
11	538335	Hex Nut (1/4-20)	4
12	2154670-01	Model I.D. Plate	1

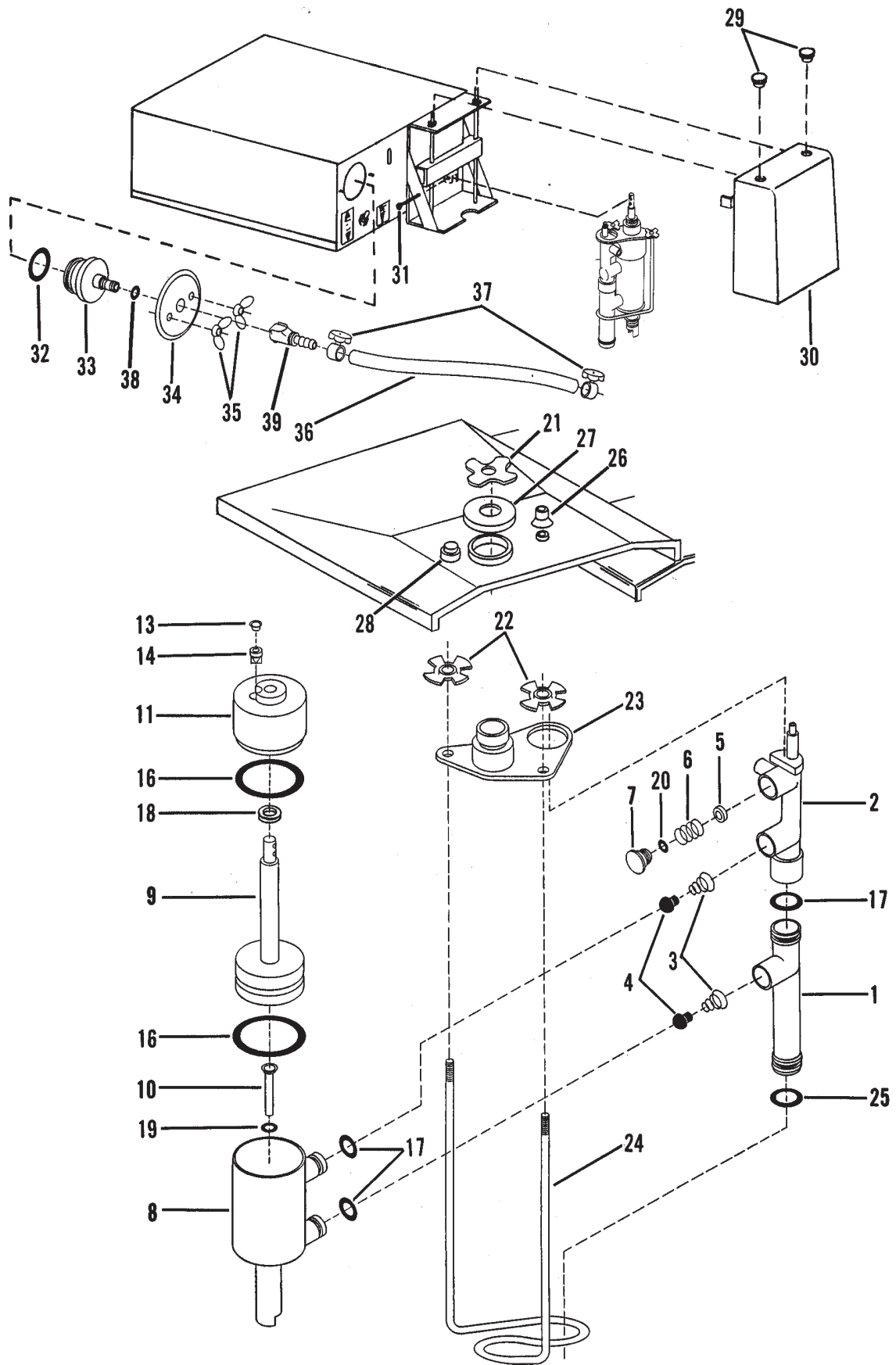
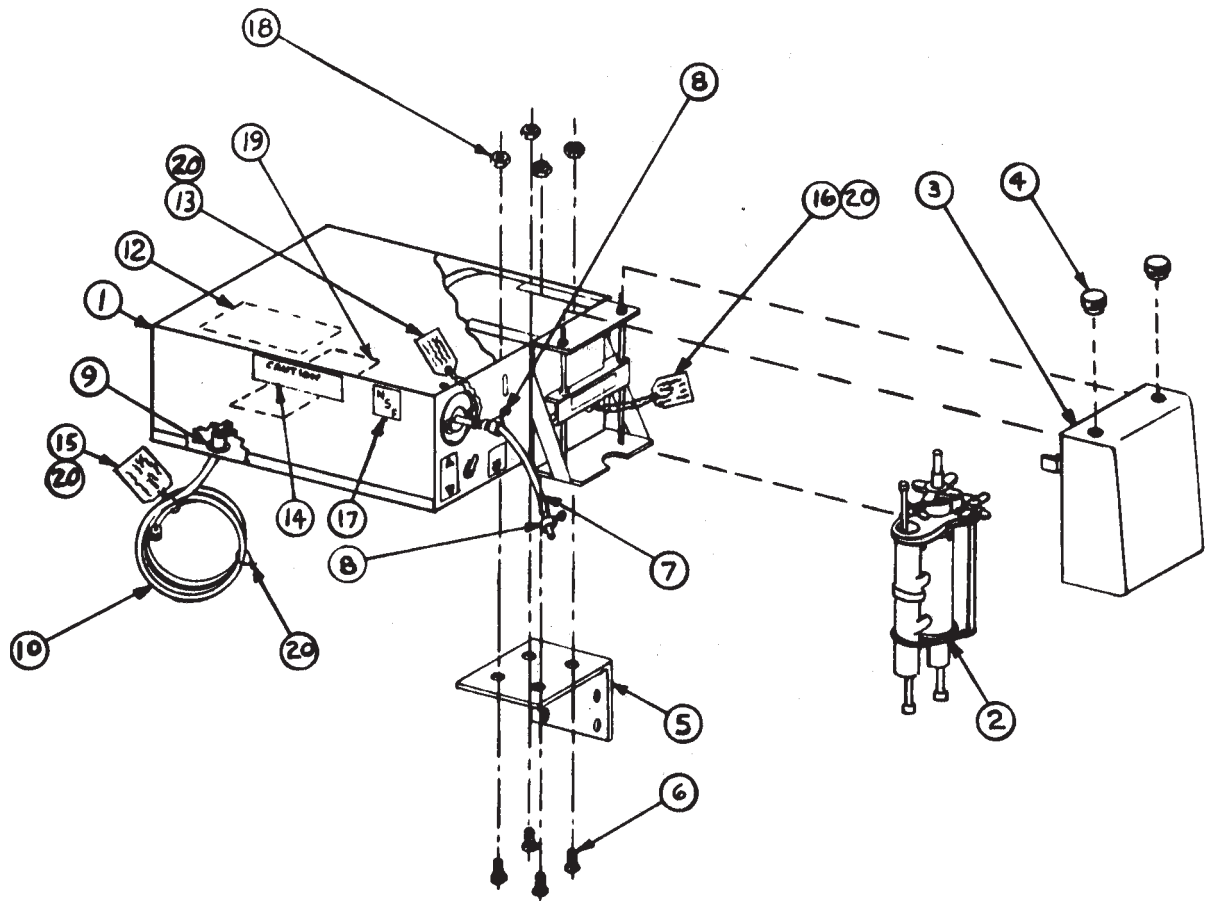

Figure 17. Mix Pump Parts

6.4. MIX PUMP PARTS

Ref. No.	Part No.	Description	Qty.
1	521185	Mix Transfer Tube Bottom (Hopper)	1
	521186	Mix Transfer Tube Bottom (Remote)	1
2	3158258	Mix Transfer Tube Top	1
3	694247	Air/Mix Outlet Springs	2
4	762256	Air/Mix Outlet Valves	2
5	763041	Safety Valve	1
6	694635	Spring	1
7	2143080	Valve Retainer	1
8	600070	Pump Cylinder Body	1
9	2107946	Piston Shaft	1
10	2107950	Mix Inlet Valve	1
11	3127452	Cylinder Top	1
13	221548	Air Inlet Valve	1
14	762274	Air Inlet Check Valve	1
16	624776	"O"-Rings	2
17	624585	Transfer Tube "O"-Rings	3
18	624594	Piston Quad Ring	1
19	624556	"O"-Ring	1
20	624564	Valve Retainer "O"-Ring	1
21	2107959	Large Hand Nut	1
22	1115840	Small Hand Nuts	2
23	2107955	Top Lock Plate	1
24	264019	Clamp Rod	1
25	624577	Mix Transfer Tube "O"- Ring (Hopper)	1
26	681511	Shield (Hopper)	1
27	1107958	Flange Washer (Hopper)	1
28	2119012	Liquid Level Indicator (Hopper)	1
29	482004	Black Knob	2
30	3147873	Safety Guard	1
31	570967	Drive Pin	1
32	624676	"O"-Ring - Manifold	1
33	513011	Manifold - Quick Connect	1
34	1111815	Locking Plate Washer	1
35	539408	Wing Nuts	2
36	756190	Tubing	1
37	264235	Hose Clamps	1
38	624545	"O"-Ring - Quick Connect Manifold	
39	312406	Quick Connect Coupling	
	2135520	"O"-Ring Kit	
	2150861	O"-Ring & Small Parts Kit	1



6.5. REMOTE PUMP FINAL ASSEMBLY

Ref. No.	Part No.	Description	Qty.
1	4154612-01	Pump Drive Remote	1
1A	4154611	Pump Drive Hopper	1
2	3143082	Pump Body Remote	1
2A	3143083	Pump Body Hopper	1
3	3147873	Safety Guard	1
4	482004	Black Knobs	2
5	3151630	Motor Mounting Plate - Remote	1
6	644106	Hex Cap Screw (1/2-20)	4
7	756190	Tubing	1
8	264235	Hose Clamp	2
9	223162	Bushing	1
10	430022	Electrical Cord	1
12	324199	Wiring Diagram Decal	1
13	723530	Pressure Instruction Tag	1
14	324113	Grounding Decal	1
15	723529	Grounding Instruction Tag	1
16	723526	Manual Instruction Tag	1
17	324023	N.S.F. Decal	1
18	538335	Hex Nut (1/4-20)	4
19	2154670-02	Model I.D. Plate	1
20	739016	Tie Strap	4

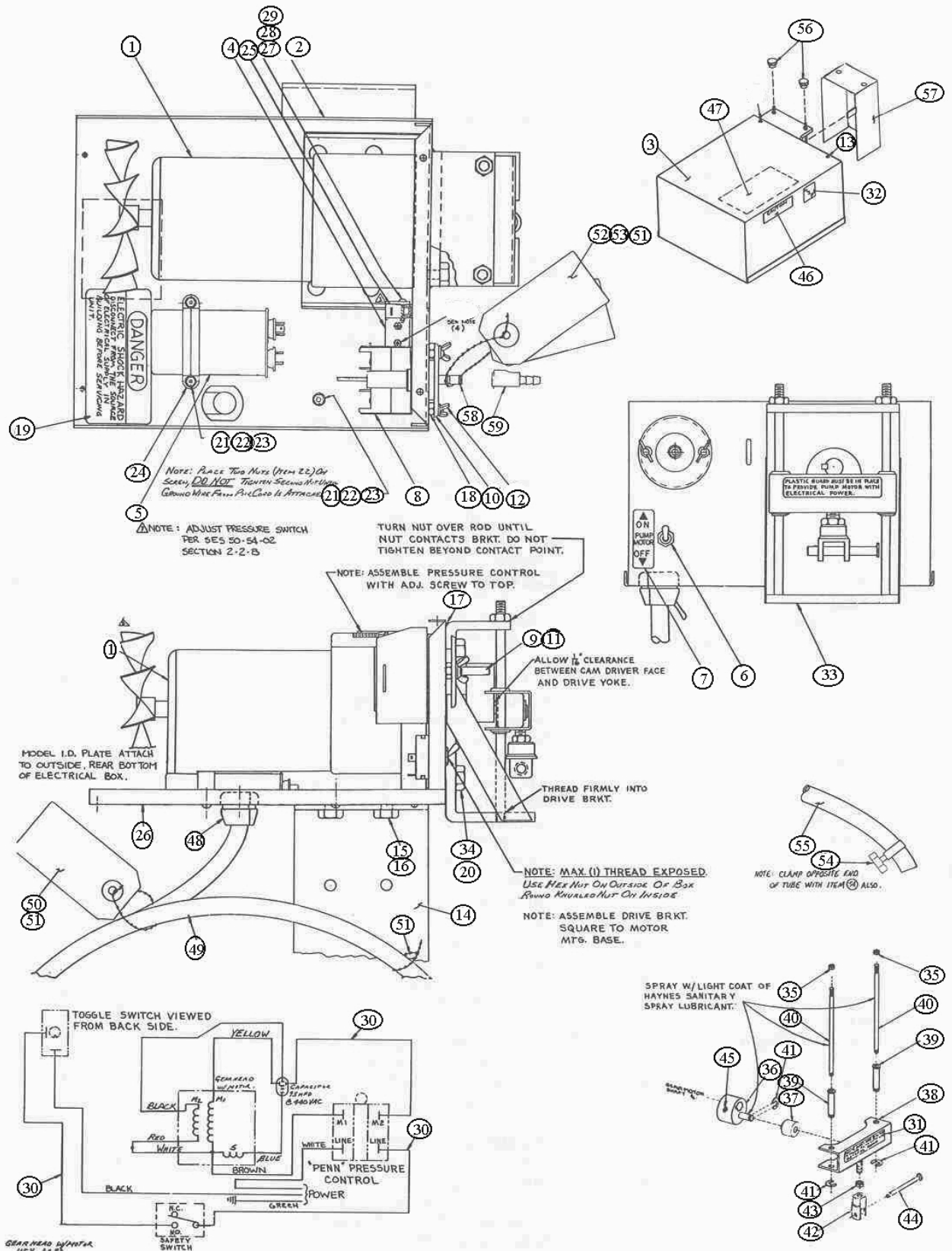

Figure 19. Pump Drive Assembly

6.6. PUMP DRIVE ASSEMBLY

Ref. No.	Part No.	Description	Qty.
	2154609-01	Gear Motor Ass'y. - Remote	1
1	2154610-01	Gear Motor Ass'y. – Hopper	1
2	3136896	Electrical Box	1
3	3153382	Electrical Box Cover	1
4	1144438	MTG Bracket (Safety Switch)	1
5	231041	Capacitor 7.5 MFD @ 440 VAC- V.W. Motor	1
6	718532	Toggle Switch S.P.S.T.	1
7	324150	Decal – Pump Motor Switch	1
*	394463	Protector Circuit, 1.5A (* Not Shown)	1
8	717920-SV	Pressure Control Ass'y.	1
9	513011	Manifold Assy-Pressure Control-Quick Connect	1
10	1111815	Locking Plate Washer	1
11	624676	"O"-Ring Pressure Switch Manifold #513004	1
12	539408	Wing Nut # 10-24 Stainless	2
13	649000-23	Screw, THD Forming –8-32 x 3/8 LG (S.S.)	4
14	3151630	Motor Mtg. Plate	1
15	644115	Hex HD. Cap Screw – ¼-20 x ¾ LG	4
16	538335	Nut, Hex ¼-20 Locking Flange	4
17	M002468	Sealant, Clear – G.E. Silicone	As Req'd
18	538296	Hex Nut #10-24	2
19	324105	Decal – Danger – Elec. Shock Hazard	1
20	M820172	Loctite 242 (Blue)	As Req'd
21	647691	Screw – 10-24 x ¾" LG	3
22	538297	Nut – 10-24	4
23	766948	Washer Shake Proof	3
24	200023	Capacitor Bracket	1
25	1170836-SV	Switch, Safety – Cherry #E13-2L	1
26	2146015	Model Identification Plate	1
27	647441	Screw, Machine – 6-32 x 1" LG	2
28	766933	Washer, Shake Proof #6	4
29	538265	Nut, Hex #16-32 C.P.	4
30	430292/430292A	Harness, Wire W./Terms.	3
31	324148	Decal – Attention – Plastic Guard	1
32	324023	Decal – N.S.F.	4
33	3136897	Drive Bracket (Bison)	1
34	644091	Capscrew – ¼-20 x ½" LG	4
35	538329	Hex Nut, Nylock ¼-20	6
36	2108109	Cam Driver Ass'y.	1
37	1108112	Cam Roller	1
38	2112087	Drive Yoke Ass'y.	1
39	1108116	Guide Bushing	2
40	1108117	Guide Rod	2
41	625407	"E"-Ring – Truarc #5133-37	3
42	1112082	Drive Clevis	1
43	538401	Nut, Jam ½-20	1
44	570967	Cotterless Clevis Pin ¼ x 2 LG	1
45	650256	Set Screw ¼ x ¼	1
46	324113	Decal-Caution	1
47	324288/324288A	Decal-Wiring Diagram	1
48	223162	Hayco Bushing #SR-7K-2	1
49	430022	Electric Cord (Lyal)	1
50	723529	Instruction Tag-Grounding	1
51	739040	Tie Strap – 7" LG	3
52	723530	Instructional Tag-Pressure	1
53	723526	Instructional Tag-Read Manual	1
54	264235	Hose Clamp	2
55	756190	Tubing –Glitex (180-m) x 8" LG	1
56	482004	Knob, Black W 1/4-20 Insert	2
57	3147873	Safety Guard-Plastic	1
58	624545	"O"-Ring – Manifold – Quick Connect	1
59	312406	Coupling, Quick Connect	1



**WARRANTY
MIX TRANSFER PUMPS**

1. **Scope:**
PW Stoelting, L.L.C. (“Stoelting”) warrants to the first user (the “Buyer”) that the mix transfer pumps manufactured by Stoelting will be free from defects in materials and workmanship under normal use and proper maintenance appearing within twelve (12) months after the date that such equipment is originally installed.

2. **Disclaimer of Other Warranties:**

THIS WARRANTY IS EXCLUSIVE; AND STOELTING, HEREBY DISCLAIMS ANY IMPLIED WARRANTY OF MERCHANTABILITY OR FITNESS FOR PARTICULAR PURPOSE.

3. **Remedies:**
Stoelting’s sole obligations, and Buyer’s sole remedies, for any breach of this warranty shall be the repair or (at Stoelting’s option) replacement of the affected component at Stoelting’s plant in Kiel, Wisconsin, or (again, at Stoelting’s option) refund of the purchase price of the affected equipment, and, during the first twelve (12) months of the warranty period, deinstallation/reinstallation of the affected component from/into the equipment. Those obligations/remedies are subject to the conditions that Buyer (a) signs and returns to Stoelting, upon installation, the Start-Up and Training Checklist for the affected equipment, (b) gives Stoelting prompt written notice of any claimed breach of warranty within the applicable warranty period, and (c) delivers the affected equipment to Stoelting or its designated service location, in its original packaging/crating, also within that period. Buyer shall bear the cost and risk of shipping to and from Stoelting’s plant or designated service location.

4. **Exclusions and Limitations:**
This warranty does not extend to parts, sometimes called “wear parts”, which are generally expected to deteriorate and to require replacement as equipment is used, including as examples but not intended to be limited to o-rings, hoses, seals, and drive belts. All such parts are sold

AS IS.

Further, Stoelting shall not be responsible to provide any remedy under this warranty with respect to any component that fails by reason of negligence, abnormal use, misuse or abuse, use with parts or equipment not manufactured or supplied by Stoelting, or damage in transit.

THE REMEDIES SET FORTH IN THIS WARRANTY SHALL BE THE SOLE LIABILITY STOELTING AND THE EXCLUSIVE REMEDY OF BUYER WITH RESPECT TO EQUIPMENT SUPPLIED BY STOELTING; AND IN NO EVENT SHALL STOELTING BE LIABLE FOR ANY INCIDENTAL OR CONSEQUENTIAL DAMAGES, WHETHER FOR BREACH OF WARRANTY OR OTHER CONTRACT BREACH, NEGLIGENCE OR OTHER TORT, OR ON ANY STRICT LIABILITY THEORY.