



Model CC101 / CC202 / CC303 / CC404
OPERATORS MANUAL

Manual No. 513642

Rev.2

This manual provides basic information about the machine. Instructions and suggestions are given covering its operation and care.

The illustrations and specifications are not binding in detail. We reserve the right to make changes to the machine without notice, and without incurring any obligation to modify or provide new parts for machines built prior to date of change.

DO NOT ATTEMPT to operate the machine until instructions and safety precautions in this manual are read completely and are thoroughly understood. If problems develop or questions arise in connection with installation, operation, or servicing of the machine, contact Stoelting.



stoeltingfoodservice.com

Stoelting Foodservice Equipment
502 Highway 67
Kiel, WI 53042-1600
U.S.A.

Main Tel: 800.558.5807
Fax: 920.894.7029

Customer Service: 888.429.5920
Fax: 800.545.0662
Email: foodservice@stoelting.com

© 2014 PW Stoelting, LLC

A Few Words About Safety

Safety Information

Read and understand the entire manual before operating or maintaining Stoelting equipment.

This manual provides the operator with information for the safe operation and maintenance of Stoelting equipment. As with any machine, there are hazards associated with their operation. For this reason safety is emphasized throughout the manual. To highlight specific safety information, the following safety definitions are provided to assist the reader.

The purpose of safety symbols is to attract your attention to possible dangers. The safety symbols, and their explanations, deserve your careful attention and understanding. The safety warnings do not by themselves eliminate any danger. The instructions or warnings they give are not substitutes for proper accident prevention measures.

If you need to replace a part, use genuine Stoelting parts with the correct part number or an equivalent part. We strongly recommend that you do not use replacement parts of inferior quality.



Safety Alert Symbol:

This symbol Indicates danger, warning or caution. Attention is required in order to avoid serious personal injury. The message that follows the symbol contains important information about safety.

Signal Word:

Signal words are distinctive words used throughout this manual that alert the reader to the existence and relative degree of a hazard.



The signal word "WARNING" indicates a potentially hazardous situation, which, if not avoided, may result in death or serious injury and equipment/property damage.



The signal word "CAUTION" indicates a potentially hazardous situation, which, if not avoided, may result in minor or moderate injury and equipment/property damage.

CAUTION

The signal word "CAUTION" not preceded by the safety alert symbol indicates a potentially hazardous situation, which, if not avoided, may result in equipment/property damage.

NOTE (or NOTICE)

The signal word "NOTICE" indicates information or procedures that relate directly or indirectly to the safety of personnel or equipment/property.

TABLE OF CONTENTS

Section	Description	Page
1	Description and Specifications	
1.1	Description.....	1
1.2	Specifications	2
1.3	International Electrical Specifications	5
2	Installation Instructions	
2.1	Safety Precautions	7
2.2	Receiving the Custard Machine.....	7
2.3	Machine Installation	7
A.	Running Line Sets.....	7
B.	Running Electrical Connections	8
C.	Plumbing Connections	8
D.	Receiving and Installing Remote Condensing Units	9
E.	Setting in Place and Making Machine Connections	9
F.	Running Product and Setting Pressures	10
3	Initial Set-Up and Operation	
3.1	Operator's Safety Precautions.....	13
3.2	Operating Controls and Indicators.....	13
3.3	Sanitizing	15
3.4	Freeze Down and Operation	15
3.5	Mix Information	16
3.6	Removing Mix from Machine	16
3.7	Cleaning the Machine.....	16
3.8	Disassembly of Machine Parts	17
3.9	Cleaning the Machine Parts	17
3.10	Assembly of Machine	17
3.11	Routine Cleaning	18
3.12	Preventative Maintenance	18
3.13	Extended Storage.....	20
4	Troubleshooting	
4.1	Error Codes	21
4.2	Troubleshooting Error Codes.....	21
4.3	Troubleshooting Tables.....	23
5	Replacement Parts	
5.1	Decals and Lubrication	25
5.2	Auger Shaft and Faceplate Parts	26
5.3	Hopper Parts	27

SECTION 1 DESCRIPTION AND SPECIFICATIONS

1.1 DESCRIPTION

The CC series machines are continuous flow custard machines. They are equipped with fully automatic controls to provide a uniform product and feature Quick-Freeze technology. This manual is designed to assist qualified service personnel and operators in the installation, operation and maintenance of the CC series frozen custard machines.

NOTE

Product breakdown could happen quicker if product is stored in the freezing cylinders for more than one hour. After a batch is made, close the flow control and empty the contents of the freezing cylinder.



Figure 1-1 Model CC303

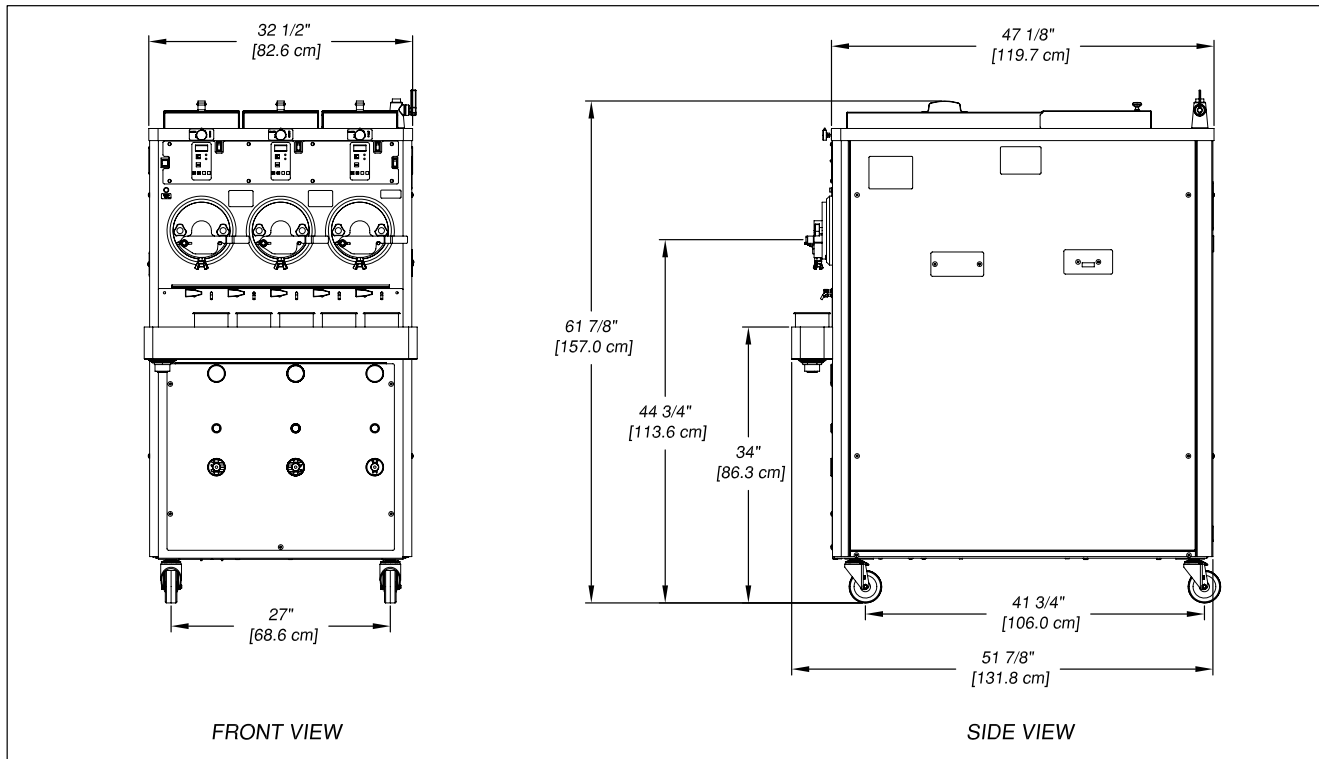

Figure 1-2 Model CC303 Dimensions

1.2 SPECIFICATIONS

	CC202A Air Cooled Remote		CC202A Water Cooled	
Dimensions	Machine	with crate	Machine	with crate
width	25-1/2" (64,8 cm)	44-1/2" (113,0 cm)	25-1/2" (64,8 cm)	44-1/2" (113,0 cm)
height	61-7/8" (157,2 cm)	67" (170,2 cm)	61-7/8" (157,2 cm)	67" (170,2 cm)
depth	47-1/8" (119,7 cm)	60" (152,4 cm)	47-1/8" (119,7 cm)	60" (152,4 cm)
Weight	632 lbs (286,6 kg)	707 lbs (320,6 kg)	930 lbs (421,8 kg)	1005 lbs (455,8 kg)
Electrical	1 Phase, 208-240 VAC, 60Hz	3 Phase, 208-240 VAC, 60Hz	1 Phase, 208-240 VAC, 60Hz	3 Phase, 208-240 VAC, 60Hz
circuit ampacity (per barrel)	12A minimum	9A minimum	29A minimum	19A minimum
overcurrent protection device (per barrel)	25A maximum	15A maximum	50A maximum	30A maximum
Hopper Condensing Unit	1 Phase, 115 VAC, 60Hz NEMA5-15P power cord provided			
Drive Motor	Two - 3 hp			
Cooling	Air cooled units require one remote condensing unit (with compressor) per barrel. Condensing units #285092 and #285093 ship from the factory with 20 lbs of R-404A for up to a 50' line set. Add 1 lb of refrigerant for every 10' increase to the line set. Line set max 100'. (Remote condensers CU-0010 and CU-0020 do not ship charged and require 24 lbs of R-404A)		Water cooled units are self contained and require a Standard Hose Adapter water fitting and a 1/2" OD drain fitting for each barrel. They are charged with R-404A. Maximum water pressure of 130 psi Minimum water flow rate of 3 GPM Ideal EWT of 60°-80°F	
Hopper Volume	Two - 8.8 gallon (33,32 liters)			

	CC303A Air Cooled Remote		CC303A Water Cooled	
Dimensions	Machine	with crate	Machine	with crate
width	32-1/2" (82,6 cm)	44-1/2" (113,0 cm)	32-1/2" (82,6 cm)	44-1/2" (113,0 cm)
height	61-7/8" (157,2 cm)	67" (170,2 cm)	61-7/8" (157,2 cm)	67" (170,2 cm)
depth	47-1/8" (119,7 cm)	60" (152,4 cm)	47-1/8" (119,7 cm)	60" (152,4 cm)
Weight	895 lbs (405,9 kg)	970 lbs (439,9 kg)	1345 lbs (610,0 kg)	1420 lbs (644,1 kg)
Electrical	1 Phase, 208-240 VAC, 60Hz	3 Phase, 208-240 VAC, 60Hz	1 Phase, 208-240 VAC, 60Hz	3 Phase, 208-240 VAC, 60Hz
circuit ampacity (per barrel)	12A minimum	9A minimum	29A minimum	19A minimum
overcurrent protection device (per barrel)	25A maximum	15A maximum	50A maximum	30A maximum
Hopper Condensing Unit	1 Phase, 115 VAC, 60Hz NEMA5-15P power cord provided			
Drive Motor	Three - 3 hp			
Cooling	Air cooled units require one remote condensing unit (with compressor) per barrel. Condensing units #285092 and #285093 ship from the factory with 20 lbs of R-404A for up to a 50' line set. Add 1 lb of refrigerant for every 10' increase to the line set. Line set max 100'. (Remote condensers CU-0010 and CU-0020 do not ship charged and require 24 lbs of R-404A)		Water cooled units are self contained and require a Standard Hose Adapter water fitting and a 1/2" OD drain fitting for each barrel. They are charged with R-404A. Maximum water pressure of 130 psi Minimum water flow rate of 3 GPM Ideal EWT of 60°-80°F	
Hopper Volume	Three - 8.8 gallon (33,32 liters)			

CC404A			
Dimensions	Machine	with crate	
	width	42-1/2" (108,0 cm)	50" (127,0 cm)
	height	61-7/8" (157,2 cm)	67" (170,2 cm)
depth	47-1/8" (119,7 cm)	60" (152,4 cm)	
Weight	1135 lbs (514,8 kg)	1210 lbs (548,8 kg)	
Electrical	3 Phase, 208-240 VAC, 60Hz		
circuit ampacity (per barrel)	9A minimum		
overcurrent protection device (per barrel)	15A maximum		
Hopper Condensing Unit	1 Phase, 115 VAC, 60Hz NEMA5-15P power cord provided		
Drive Motor	Four - 3 hp		
Cooling	Air cooled units require one remote condensing unit (with compressor) per barrel. Condensing units #285092 and #285093 ship from the factory with 20 lbs of R-404A for up to a 50' line set. Add 1 lb of refrigerant for every 10' increase to the line set. Line set max 100'. (Remote condensers CU-0010 and CU-0020 do not ship charged and require 24 lbs of R-404A)	Water cooled units are self contained and require a Standard Hose Adapter water fitting and a 1/2" OD drain fitting for each barrel. They are charged with R-404A. Maximum water pressure of 130 psi Minimum water flow rate of 3 GPM Ideal EWT of 60°-80°F	
	Hopper Volume		Four - 8.8 gallon (33,32 liters)

Remote Condensing Unit (1 per barrel)			
Dimensions	Condenser		
	width	37-3/4" (95,9 cm)	
	height	17-1/4" (43,7 cm)	
depth	28-1/4" (71,7 cm)		
Weight	222 lbs (100,7 kg)		
Electrical	1 Phase, 208-230 VAC, 60Hz		
	circuit ampacity	20A minimum	3 Phase, 208-230 VAC, 60Hz 15A minimum
	overcurrent protection device	25A maximum	20A maximum
Refrigerant	R-404A		
Charge	20 lbs. (Charged at Factory)		
Refrigerated Line Sizes	Liquid Line - 3/8" Suction Line - 7/8"		

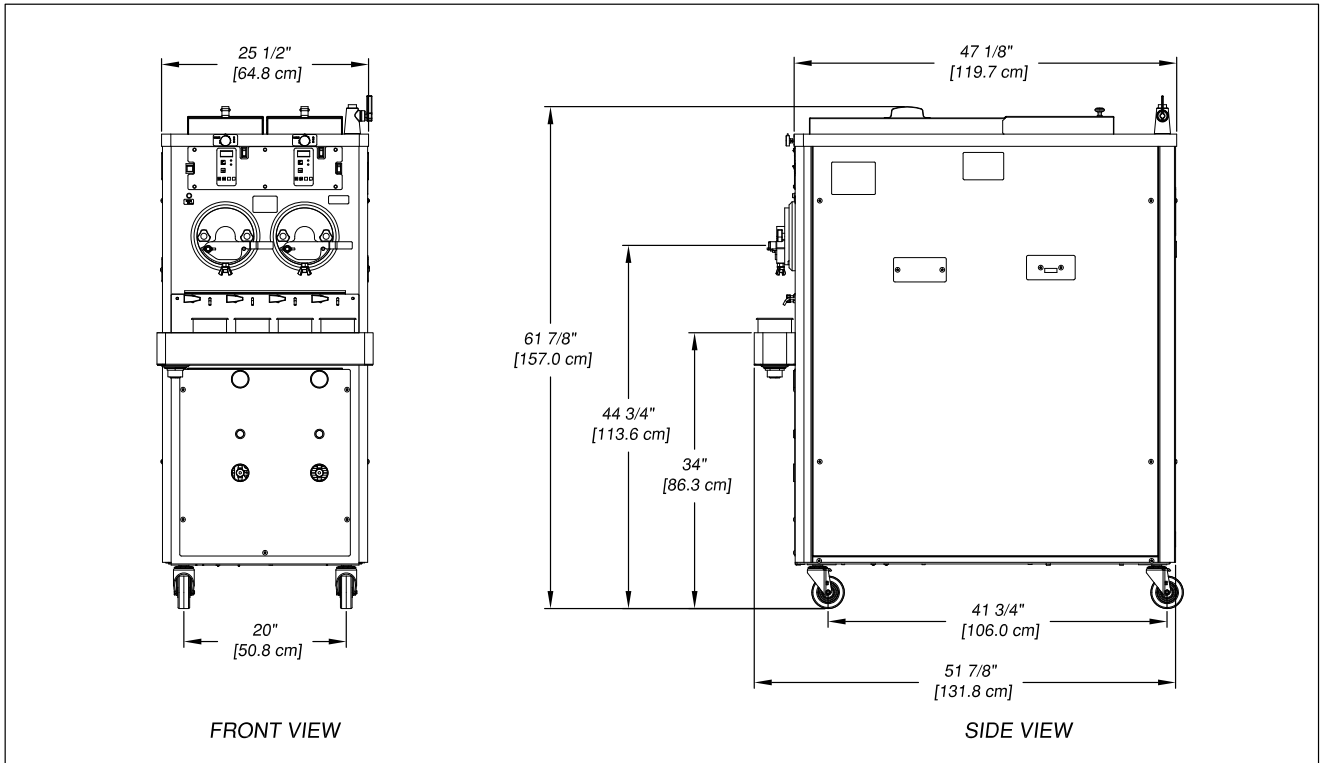

Figure 1-4 Model CC202 Dimensions

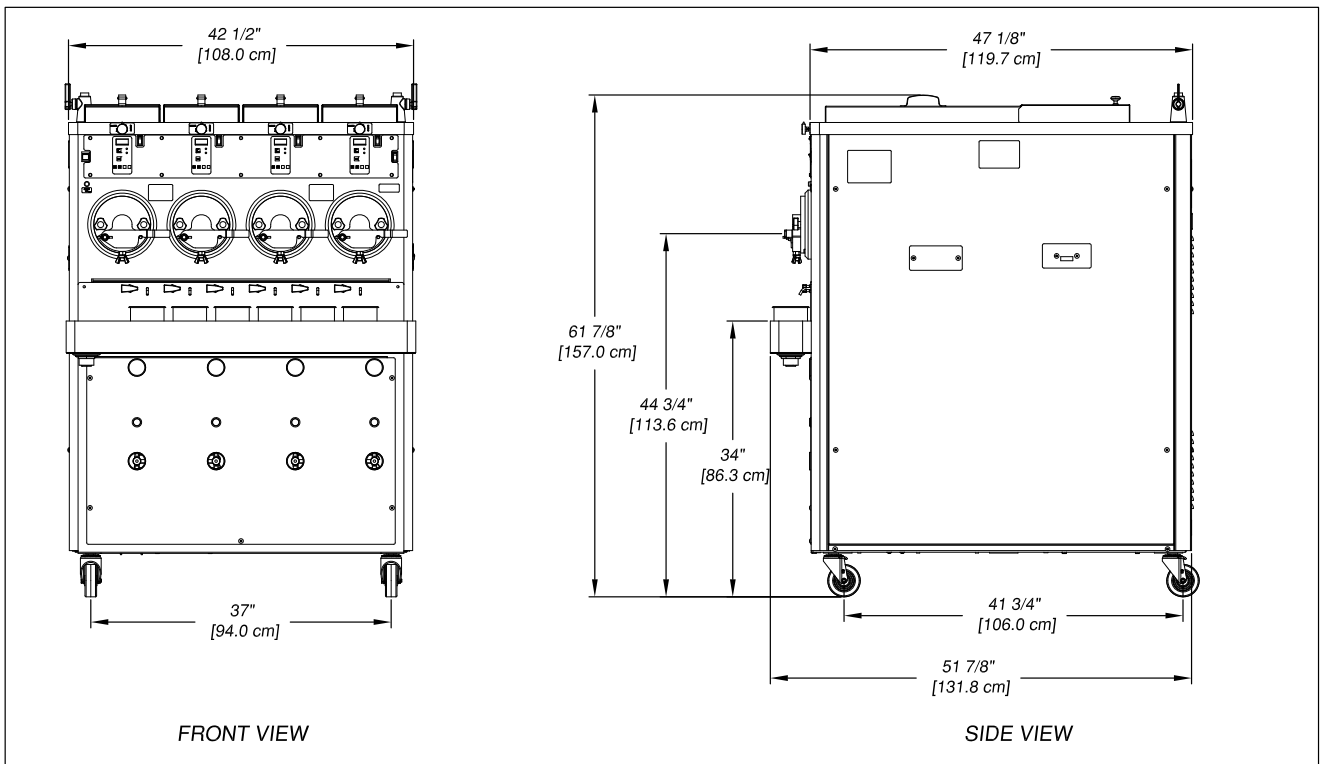

Figure 1-5 Model CC404 Dimensions

1.3 INTERNATIONAL ELECTRICAL SPECIFICATIONS

The table below shows the electrical requirements per barrel. Refer to the tables in Section 1.2 for the remainder of the specifications. There is a separate electrical circuit for each barrel.

	Air Cooled Remote		Water Cooled	
Electrical	1 Phase, 200-220 VAC, 50Hz	3 Phase, 380-415* VAC, 50Hz	1 Phase, 200-220 VAC, 50Hz	3 Phase, 380-415* VAC, 50Hz
circuit ampacity (per barrel)	12A minimum	6A minimum	32A minimum	12A minimum
overcurrent protection device (per barrel)	25A maximum	10A maximum	50A maximum	20A maximum
Hopper Condensing Unit	1 Phase, 200-240 VAC, 50Hz Requires a 15amp power cord			
Drive Motor	Three - 2 hp			

* The 380-415 VAC supply requires a neutral. The power supply must be 5 wire for proper operation.

	Remote Condensing Unit (1 per barrel)	
Electrical	1 Phase, 200-220 VAC, 50Hz	3 Phase, 380-415 VAC, 50Hz
circuit ampacity	20A minimum	15A minimum
overcurrent protection device	25A maximum	20A maximum
Refrigerant	R-404A	
Charge	20 lbs. (Charged at Factory)	

SECTION 2 INSTALLATION INSTRUCTIONS

2.1 SAFETY PRECAUTIONS

Do not attempt to operate the machine until the safety precautions and operating instructions in this manual are read completely and are thoroughly understood.

Take notice of all warning labels on the machine. The labels have been put there to help maintain a safe working environment. The labels have been designed to withstand washing and cleaning. All labels must remain legible for the life of the machine. Labels should be checked periodically to be sure they can be recognized as warning labels.

If danger, warning or caution labels are needed, indicate the part number, type of label, location of label, and quantity required along with your address and mail to:

STOELTING, INC.
ATTENTION: Customer Service
502 Hwy. 67
Kiel, Wisconsin 53042

2.2 RECEIVING THE CUSTARD MACHINE

- A. Upon arrival, check the entire machine for any damage that may have occurred during transit. With the method of packaging used, the machine should arrive in excellent condition. The carrier is responsible for all damage in transit, whether visible or concealed. Do not pay the freight bill until the machine has been checked for damage. Have the carrier note any visible damage on the freight bill. If concealed damage or a shortage is found later, advise the carrier within 10 days and request inspection. The customer must place a claim for damages and/or shortages in shipment with the carrier. Stoelting cannot make any claims against the carrier.
- B. Remove the top of the crate using a hammer or pry bar.
- C. Remove the eight lag bolts from the machine using a 1/2" ratchet. Remove the front and rear crate walls.
- D. Remove the four lag bolts located inside the left and right crate walls using 1/2" ratchet. Remove the left and right crate walls.
- E. Remove the plastic wrapping on the machine. Remove the lower front and back panel on the machine.
- F. Remove the four lag bolts located inside machine on the frame with a 9/16" ratchet. Remove the two lag bolts that hold the skid together with a 9/16" socket.

- G. If the machine has the shipping casters or if it is water-cooled, the casters will be in a box located in the hopper pan. A set of casters includes two casters with locks and two casters without locks. Screw the casters into the threaded holes and tighten them using a pair of channel locks. After installing the casters, knock out bottom 4" x 4" of the machine skid.

NOTE

If the machine does not come with casters, install the stainless steel legs. The legs are located in the hopper pan on top of the machine. After installing the legs, use a pallet jack to move machine into place.

- H. Put front and back panels on the machine.

2.3 MACHINE INSTALLATION

The following instructions are intended for a qualified electrician/refrigeration specialist. Do not attempt these procedures unless you are qualified.

CAUTION

Installation MUST be completed by a qualified electrician/refrigeration specialist

Incorrect installation may cause personal injury, severe damage to the machine and will void factory warranty.

A. RUNNING LINE SETS

NOTE

If the machine is water-cooled, proceed to "B. Running Electrical Connections".

Line sets are not supplied with the machine.

The line sets can be installed prior to receiving the custard machine.

1. An air-cooled machine requires a remote condensing unit and line set for each freezing cylinder. The line sets must be 3/8" for the liquid line and 7/8" for the suction line. When running the line sets, each 10' of vertical rise, install a p-trap in the suction line. For every horizontal line set run, pitch the suction line towards the compressor to assist with oil returning back to the compressor.
2. After the line set is installed, perform a thorough leak test. Malfunctions of the equipment due to leaks in the line set are not covered by the Stoelting/Ross warranty.

- 3 Insulate the suction line with a minimum of 3/8" wall thickness or the wall thickness required by local code. In humid areas, use thicker insulation. In areas that are exposed to extreme temperatures, insulate the liquid line to prevent excessive sub cooling or heating of the liquid refrigerant. Fasten all lines securely along ceilings, walls and roofs. Avoid creating any type of kink in the lines. The Stoelting/Ross warranty does not cover malfunctions or capacity issues with equipment caused by kinks in the line sets.
- 4 Use good piping practices when installing line sets. Seal the ends of the line sets during installation to prevent exposure to the atmosphere and foreign objects. Blow the lines out with dry nitrogen to remove any debris that might be in the line sets. When running line sets through a wall or roof, mark the lines to eliminate confusion as to which line set is running to which cylinder.

Example: Mark the liquid and suction lines with the respective cylinder number. Facing the front of the machine, cylinders are numbered left to right.
- 5 When brazing the joints, purge dry nitrogen through the lines to minimize oxidation of copper inside of the lines. The Stoelting/Ross warranty does not cover problems with the refrigeration system that are caused by oxidized material in the lines.

B. RUNNING ELECTRICAL CONNECTIONS

- 1 The machine requires a separate electrical connection for each freezing cylinder. Refer to the nameplate on the machine for proper electrical supply. Each freezing cylinder has its own electrical system and condenser so if one cylinder fails, the other cylinder will still be operational.

NOTE

An air-cooled machine needs two circuits for each freezing cylinder, one for the remote condensing unit and one for the freezing cylinder.

A water-cooled machine needs one circuit for each freezing cylinder.

- 2 The electrical boxes are located behind the lower front panel. Labels indicate which cylinder each electrical box powers. No pigtailed wires are supplied with the machine or condensing unit.
- 3 If the condensing unit is on the roof or ground, a quick disconnect box needs to be installed to provide power.

- 4 Do not turn on the power to the machine or the condensing unit until the refrigeration lines have been connected and the system has been charged with refrigerant. Label the circuit breakers with information regarding which cylinder and condensing unit the breaker is designated for to prevent confusion if power ever needs to be shut off.
- 5 When connecting power to the machine, run the line under the machine and through the bottom of the electrical box. Remove the electrical box cover by loosening the four screws. The screws do not have to be removed. Connect the power to the terminal strip. The terminal strip is labeled L1, L2, L3, and GND. After connections are made, place the cover on the electrical box, but do not tighten the cover (for single-phase machines the cover can be tightened). The electrical box may need to be accessed when checking for proper rotation of the motor.

C. PLUMBING CONNECTIONS

- 1 On water-cooled machines, the water inlet is a standard garden hose connection and the water outlet is 5/8" OD copper tubing. The connections are located at the back of the machine. Remove the rear panel to access the connections. Run the plumbing under the machine frame. Water-cooled machines use approximately 3 gallons of 75°F water per minute when the compressor is operating. The machine does not use any water when not in use.
- 2 The machine is equipped with a dipping trough that requires a water inlet line and a drain line. The water inlet has 1/2" NPT close nipple fitting. Install a shutoff valve in the water inlet line. The drain connection is 1-1/2". Run a drain line from the trough to a drain on the floor. Leave enough slack in the drain line so that the lower front panel can be easily removed for service.

D. RECEIVING AND INSTALLING REMOTE CONDENSING UNITS

NOTE

The remote condensing units may be sent prior to delivery of the freezer.

The freezer requires one remote condensing unit per cylinder.

Remote condenser models 285092 and 285093 are shipped from the factory charged with 20 lbs of R404a refrigerant.

Remote condenser models CU-0010 and CU-0020 are shipped from the factory without a refrigerant charge.

- 1 Upon arrival, check the entire remote condenser units for any damage that may have occurred during transit. With the method of packaging used, the remote condensers should arrive in excellent condition. The carrier is responsible for all damage in transit, whether visible or concealed. Do not pay the freight bill until the remote condenser units have been checked for damage. Have the carrier note any visible damage on the freight bill. If concealed damage or a shortage is found later, advise the carrier within 10 days and request inspection. The customer must place a claim for damages and/or shortages in shipment with the carrier. Stoelting cannot make any claims against the carrier.
- 2 Remove cardboard covering off the condensing units.
- 3 Place the condensing units in their predetermined location, either on the roof or on the ground. A crane or forklift will be needed if the units will be placed on a roof. The condensing units weigh approximately 200 lbs. each.
- 4 Using ratchet with a 1/2" socket, remove the two lag bolts that secure the condensing unit to the pallet.
- 5 Place the condensing units on 4" x 4" treated wood or similar material so that the units are not sitting directly on the ground or the roof. Secure the condensing units to the 4" x 4" using lag bolts. Adhere to all local, state, and federal codes governing this type of installation. Some areas have specific "hurricane-proof" requirements

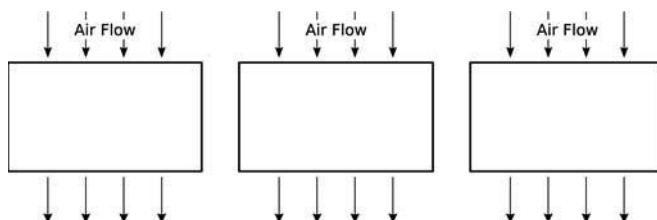

Figure 2-1 Remote Condenser Installation
(Top View)

for roof installations. Allow at least 3 feet of clearance on the air intake and discharge sides of the condensers. Do not set the condensers so that one is blowing air directly into the other condensing unit. The ideal set up is to have all the condensing units set in a row (Fig. 2-1).

NOTE

On CU-0010 and CU-0020 remote condenser models, use an Allen wrench to open the shut off valves and release some of the nitrogen charge in the condensing unit. The shut off valves are located on the outside of the condensing unit. If no nitrogen is present then the unit needs to be leak checked prior to connecting the refrigeration lines.

- 7 Braze the suction line and liquid line from the line sets to the condensing unit. When brazing, wrap the shut off valve with a cold wet rag. If the valve is not wrapped, damage to the valve may result. When installing the suction line, angle it towards the condensing unit so that oil can flow back towards the compressor.
- 8 Use good piping practices. Keep pipes as clean as possible. Do not let any debris or copper shavings get inside system otherwise the refrigeration valves may not work properly.

E. SETTING IN PLACE AND MAKING MACHINE CONNECTIONS

- 1 Roll the machine into the desired location. Leave adequate space around the machine for the removal of service panels. Remove the left, right, back and lower front service panels.

NOTE

After the refrigeration lines are connected, air-cooled machines cannot be moved.

- 2 Use a pallet jack or floor jack to lift the front of the machine, remove the two shipping casters with a pair of channel locks, and install the stainless steel legs. Make sure the legs are adjusted all the way in, and screw two of the legs into the frame. Secure them tightly using channel locks. Repeat with the back of the machine.

NOTE

If the machine is water-cooled, casters are standard with machine.

- 3 Accurate leveling is necessary to ensure proper operation. Place a bubble level on top of the machine at each corner to check for level condition. If adjustment is necessary, level the machine by turning the bottom part of each leg or caster in or out.

To finish installing a water-cooled machine, proceed to "F. Running product and setting pressures for the custard machine".

4 Connect the refrigeration lines from the line sets to the machine. Access the machine from the left or right service panel. The refrigeration system has a charge of dry nitrogen. Use caution when connecting the lines. Connect the suction line first then connect the liquid line. Run the refrigeration lines under the machine. There is approximately 6" of clearance between machine and the floor. The stainless steel legs are adjustable and can raise the machine up to 7" off the floor if necessary. Wrap the suction solenoid in a cold wet rag when soldering to prevent damage to the solenoid. Also, be aware of the electrical conduit inside custard machine while soldering the refrigeration lines. A liquid line dryer is supplied with the machine and should be the last connection made in the system. Use good piping techniques to keep the system clean. Do not leave the lines open and exposed for a long period.

5 After finishing the refrigeration connections, connect power to the machine. Refer to "B. Running Electrical Lines" for the proper procedures. Check the rotation of the beater shaft. When looking at the machine from the front, the shaft needs to turn counterclockwise. If the shaft is turning the wrong direction, shut off power to the cylinder and switch the L1 and L3 wires. Check rotation again to verify the shaft is rotating counterclockwise. Once verified, tighten the screws on the electrical box cover.

If the machine is single phase and the beater shaft rotation is clockwise, then complete one of the following procedures. Check rotation after each procedure.

A. Change programming on variable speed drive to reverse motor.

B. Change the T1 and T3 output leads going to the motor from the drive.

C. Change the leads inside the motor electrical box.

NOTE

On CU-0010 and CU-0020 remote condenser models, check the refrigeration systems for leaks. When pressurizing the system, turn the refrigeration switch to hold position to energize the suction solenoid. Also, make sure that the shut off valves are open on the remote condensing unit. Check the refrigeration system with a minimum of 100 psi. Make sure the system will hold the pressure for a minimum of 2 hours.

After the leak check, connect a vacuum pump to the system and evacuate it to 500 microns for a minimum of 1 hour. Make sure the suction solenoid and the shut off valves on the condensing unit are opened. Perform a standing vacuum test. If the vacuum deteriorates and continues to rise there is a leak. Find it, repair it, and repeat the evacuation procedure until the machine passes a standing vacuum test. While the refrigeration system is under a vacuum, insulate the suction line. Insulation is needed up to the shut off valve on the condensing unit. Use 3/8" tube insulation or insulation required by local code.

8 Use good refrigeration practices to charge the system with the required charge (see below). Make sure the suction solenoid is energized and that the shut off valves are open.

Model	Hopper Charge (factory charge)	Air-Cooled Charge per cylinder	Water-Cooled Charge per cylinder
CC101	16 oz of R-134a	20 lbs of R-404a*	10 lbs of R-404a
CC202	18 oz of R-134a	20 lbs of R-404a*	10 lbs of R-404a
CC303	19 oz of R-134a	20 lbs of R-404a*	10 lbs of R-404a
CC404	20 oz of R-134a	20 lbs of R-404a*	10 lbs of R-404a
M202	N/A	20 lbs of R-404a	8 lbs of R-404a

* Remote condensing units #285092 and #285093 ship from the factory with 20 lbs of R-404a. Machines with remote condensing units #CU-0010 or CU-0020 require 24 lbs of R-404a supplied on-site.

Figure 2-2 Refrigeration Charges

NOTE

Air cooled units require one remote condensing unit (with compressor) per barrel. Condensing units #285092 and #285093 ship from the factory with 20 lbs of R-404A for up to a 50' line set. Add 1 lb of refrigerant for every 10' increase to the line set. Line set max 100'. (Remote condensers CU-0010 and CU-0020 do not ship charged and require 24 lbs of R-404A).

F. RUNNING PRODUCT AND SETTING PRESSURES FOR THE CUSTARD MACHINE

NOTE

Complete the Custard Machine Start-Up and Training Checklist located with the spare parts kit or in the back of this manual and send it to Stoelting.

1 Remove all spare parts from the hopper before running product. Unwrap the parts and check for damage. Refer to the list in the back of this manual to make sure no parts are missing. The cylinders need to be under a load to set the pressures. If custard is not available, RV antifreeze can be used as an alternative. Mix the RV antifreeze in a concentration of 1 part antifreeze to 1 part water. If RV antifreeze is used, the pressures will need to be rechecked when custard mix is available. The RV antifreeze will indicate that the system is functioning correctly.

- 2 Disassemble, clean and sanitize each freezing cylinder. Refer to the Section 3 for proper instructions.
- 3 After assembling and sanitizing the machine, add custard mix to the hopper. Follow the instructions in the Section 3 to start freezing the custard (run one cylinder at a time to set the pressures). Connect gauges to the suction line and the discharge line. When product starts coming out of the faceplate, locate the low pressure gauge on the front of the machine and set the AXV to 30 psi. Remove the white plastic cap from the AXV and turn the valve counterclockwise to decrease the pressure or clockwise to increase the pressure. Turn the valve 1/4 turn at a time and wait at least 1 minute before making another adjustment. Connect a gauge to the suction line at the compressor and make sure the pressure is 25 psi. Adjust the crankcase pressure regulator (CPR) if the pressure is not correct. Remove threaded brass cap on the front of the CPR and adjust the valve with a 5/16" Allen wrench. Connect a gauge to the suction line at the hopper and adjust the hopper AXV to 55 psi.
- 4 Check the faceplate to see if the custard is at the desired texture and temperature. The standard normal serving temperature of frozen custard coming out of the machine is 18°-21°F.
- 5 Set the pressures for the remaining cylinders.

NOTE

If the machine is water-cooled, the discharge pressure was already set at the factory. Run custard mix through the machine to double-check and fine-tune the discharge pressure for the particular mix being used.

The remote condenser unit has a head pressure control set for 245 psi.

Custard mixes that use an extract flavoring will also run differently. Try different pressure settings by adjusting the AXV. Adjust the pressure setting between 28-32 psi (the machine will not operate correctly if the AXV is set lower than 28 psi).

- 6 If the machine is equipped with the lemon ice option, set the lemon ice AXV. The lemon ice option is designated for one cylinder (right cylinder). With the system still running product, turn the lemon ice switch on. The AXV is located behind the front panel. Set the lemon ice AXV for 38-42 psi.
- 7 When testing is done, take the cylinders apart and clean the custard machine. Refer Section 3 for details.

SECTION 3 INITIAL SET-UP AND OPERATION

3.1 OPERATOR'S SAFETY PRECAUTIONS

SAFE OPERATION IS NO ACCIDENT; observe these rules:

- A. Know the machine. Read and understand the Operating Instructions.
- B. Notice all warning labels on the machine.
- C. Wear proper clothing. Avoid loose fitting garments, and remove watches, rings or jewelry that could cause a serious accident.
- D. Maintain a clean work area. Avoid accidents by cleaning up the area and keeping it clean.
- E. Stay alert at all times. Know which switch, push button or control you are about to use and what effect it is going to have.
- F. Disconnect electrical cord for maintenance. Never attempt to repair or perform maintenance on the machine until the main electrical power has been disconnected.
- G. Do not operate under unsafe operating conditions. Never operate the machine if unusual or excessive noise or vibration occurs.

3.2 OPERATING CONTROLS AND INDICATORS

Before operating the machine, it is required that the operator know the function of each operating control. Refer to Figure 3-1 for the location of the operating controls on the machine.

WARNING

Moving machinery can grab, mangle and dismember. Place the Freezing Cylinder Off/On switch in the OFF position before disassembling for cleaning or servicing.

A. Hopper Refrigeration OFF-ON Switch

The Hopper Refrigeration OFF-ON switch is a two-position toggle switch used to supply power to the the hoppers. When the switch is in the OFF position, the hopper off light will flash. When the switch is put in the ON position, the hopper refrigeration system will operate.

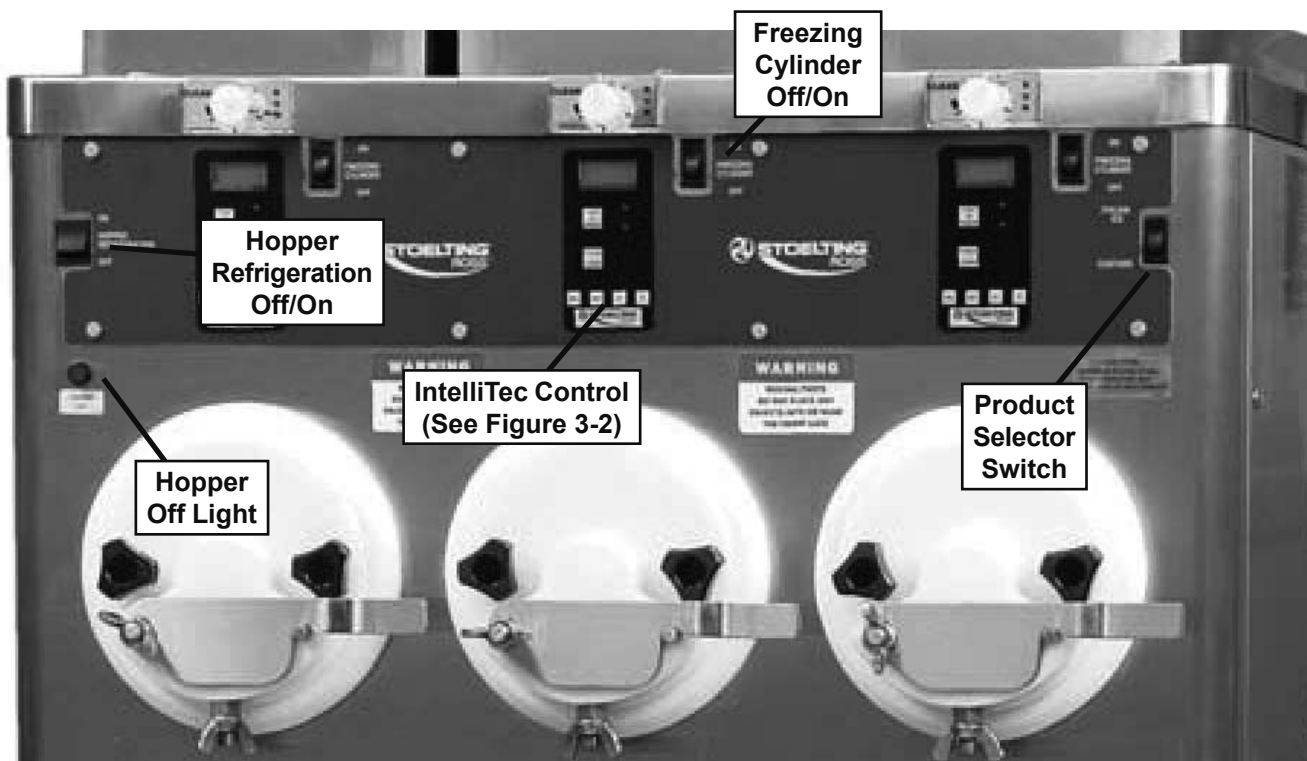

Figure 3-1 Machine Controls

B. Freezing Cylinder Off/On

The Freezing Cylinder OFF/ON switch is a two position toggle switch used to supply power to the freezing cylinder control circuit. When the switch is in the OFF position, the freezing cylinder's refrigeration system and auger will not operate. When the switch is in the ON position, the freezing cylinder will be operational.

C. Product Selector Switch

The product selector switch changes the refrigeration profile of the right freezing cylinder to allow two different products to be made. Before the machine is in ready mode, this switch can be moved to the desired profile.

D. Hopper Off Light

A flashing light indicates the Hopper Refrigeration Switch is in the OFF position; no refrigeration is being supplied to the hopper. Place the Hopper Refrigeration switch in the ON position for hopper refrigeration..

E. PUSH TO FREEZE Button

The PUSH TO FREEZE button is used to initiate the run mode. To start the machine, place the Freezing Cylinder OFF-ON switch in the ON position and press the PUSH TO FREEZE button.

F. LEDs

The membrane switch features two lights; a green LED and an amber LED. The green LED will flash when the freezing cylinder is near ready mode and stay lit during ready mode. The amber LED is lit during standby, purge and clean modes.

NOTE

If the machine enters an error condition, alternating green and amber lights will flash. The LCD will display an error. Turn the Freezing Cylinder OFF-ON switch to the OFF position, correct the problem (Refer to Troubleshooting in Section 4) and turn the machine back on.

G. PURGE/CLEAN Button

PURGE Mode - When the PURGE/CLEAN button is pressed, the auger will rotate. A PURGE message will display on the screen along with a 5 minute timer. Hopper refrigeration will continue to run. When the timer gets to 0:00 and no other buttons are pressed, the machine will go into standby mode.

CLEAN Mode - During PURGE mode, if the PURGE/CLEAN button is pressed and held for 3 seconds, the CLEAN mode will begin. The auger will continue to rotate and hopper refrigeration will stop.

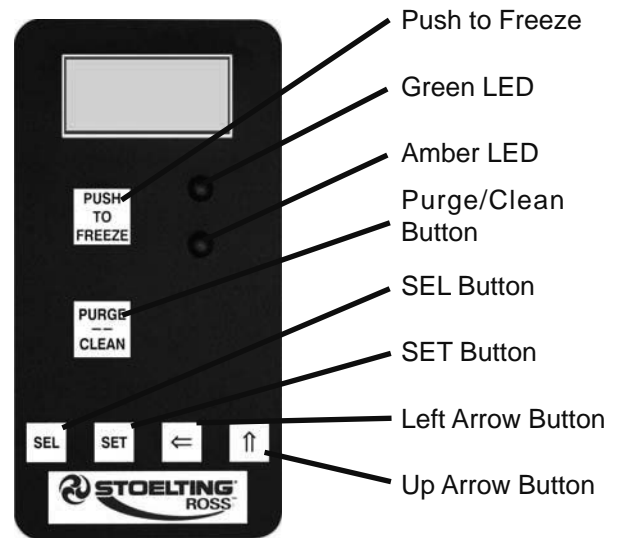

Figure 3-2 IntelliTec Control

H. Mix Low Light Indicator

The MIX LOW message will appear on the LCD display to alert the operator to a low mix condition. The message will display when there is approximately one gallon of mix left in the hopper. When the MIX LOW message is displayed, refill hopper immediately.

NOTE

Failure to refill hopper immediately may result in operational problems.

I. Menu Navigation Buttons

The Menu Navigation Buttons are primarily used for machine calibration.

Selection Button (SEL) The SEL button is not functional in the normal operation mode. This button is only used by service technicians for machine calibration.

Set Button (SET) The SET button is not functional in the normal operation mode. This button is only used by service technicians for machine calibration.

Left Arrow Button (←) Pressing any button on the control panel will automatically illuminate the display. The backlight will turn off several seconds after use. To keep the display constantly lit, press and hold the left (←) button for five seconds. The backlight function can be reset to normal operation in the same manner.

Up Arrow Button (↑) The ↑ button is not functional in the normal operation mode. This button is only used by service technicians for machine calibration.

J. Front Door Safety Switch

The front door safety switch prevents the auger from turning when the front door is removed. The switch is open when the door is not in place and closed when the door is properly installed.

3.3 SANITIZING

Sanitizing must be done after the machine is cleaned and just before the hopper is filled with mix. Sanitizing the night before is not effective. However, you should always clean the machine and parts after each use.

THE UNITED STATES DEPARTMENT OF AGRICULTURE AND THE FOOD AND DRUG ADMINISTRATION REQUIRE THAT ALL CLEANING AND SANITIZING SOLUTIONS USED WITH FOOD PROCESSING EQUIPMENT BE CERTIFIED FOR THIS USE.

When sanitizing the machine, refer to local sanitary regulations for applicable codes and recommended sanitizing products and procedures. The frequency of sanitizing must comply with local health regulations.

Mix sanitizer according to manufacturer's instructions to provide a 100 parts per million strength solution. Mix sanitizer in quantities of no less than 2 gallons (7.5 liters) of 90° to 110°F (32° to 43°C) water. Allow sanitizer to contact the surfaces to be sanitized for 5 minutes. Any sanitizer must be used only in accordance with the manufacturer's instructions.

In general, sanitizing may be conducted as follows:

- A. Prepare Stera-Sheen Green Label Sanitizer or equivalent according to manufacturer's instructions to provide a 100ppm strength solution. Mix the sanitizer in quantities of no less than 2 gallons of 90° to 110°F (32° to 43°C) water. Any sanitizer must be used only in accordance with the manufacturer's instructions.

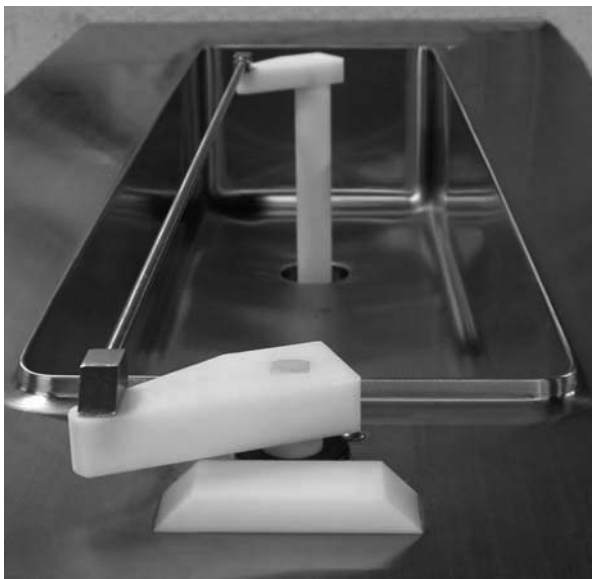

Figure 3-3 Flow Control Assembly

- B. Place the tapered end of the flow valve into the hopper drain hole with the arm pointing towards the left. Connect the flow control rod to the flow valve and the flow valve arm (Fig. 3-3).
- C. Make sure the flow control valve is shut by turning the control knob counterclockwise to the 12:00 position.
- D. Place a bucket under the slide.
- E. Pour the sanitizer into the hopper.

NOTE

A small amount of sanitizer may drain into the bucket with the flow control shut and may seep out of the rear seal.

- F. Place the Freezing Cylinder OFF-ON switch in the ON position and press the PURGE/CLEAN button. The display will read PURGE.
- G. Press and hold the PURGE/CLEAN button for 3 seconds. The display will read CLEAN and a 10 minute timer will start.
- H. Turn the flow control knob fully open (clockwise) to drain the sanitizer from the freezing cylinder.
- I. Clean sides of hopper, flow valve and underside of hopper cover using a sanitized soft bristle brush dipped in the sanitizing solution.
- J. When the sanitizer has drained from the hopper, press and hold the PURGE/CLEAN button for 3 seconds to stop the auger. Allow the freezing cylinder to drain completely.
- K. Shut off the flow control valve by turning the flow control knob counterclockwise to the 12:00 position.

3.4 FREEZE DOWN AND OPERATION

This section covers the recommended operating procedures to be followed for the safe operation of the machine.

- A. Sanitize just prior to use.

NOTE

Make sure the flow control assembly is in place before adding mix and that the flow control knob is set to the 12:00 position.

- B. Fill the hopper with 5 gallons (18.9 liters) of pre-chilled (40°F or 4°C) mix.
- E. Place the Freezing Cylinder OFF-ON switch in the ON position. The display will read STANDBY MODE.
- F. Press the PUSH TO FREEZE button. The display will read CUSTARD and a bar on the second line will start to fill. On the right cylinder the product type can be changed by moving the Product Selector switch to the Product 2 position.

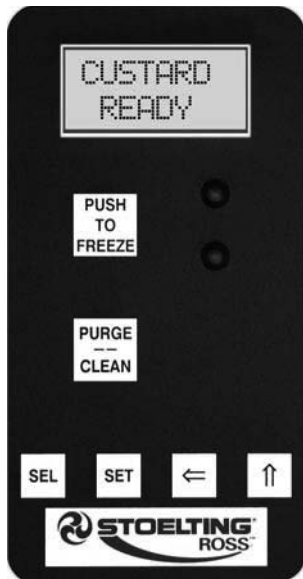

Figure 3-4 Custard Mode

NOTE

The Product Selector switch can be changed until the READY message is displayed on the second line.

- G. When the display reads CUSTARD READY, the freezing cylinder is at the correct temperature (Fig. 3-4).
- H. Open the front gate.
- I. Turn the flow control knob clockwise to the 2:00 position. A small amount of mix and remaining sanitizer will drain from the machine.
- J. Turn the flow control knob to the 1:00 position. After a few minutes, a ribbon of product starts to form.
- K. Adjust the flow control knob until the product flow fills the faceplate outlet and is at the desired texture (Fig. 3-5). The flow control knob setting will be different for each type of product.

NOTE

Adjustments take up to 1 minute before a noticeable difference is seen in the product.

NOTE

A high-pitched noise from the freezing cylinder is an indication that there is not enough mix entering the barrel. Slowly turn the flow control knob clockwise to increase the flow. It can take up to 1 minute for the adjustment to stop the noise.

3.5 MIX INFORMATION

Mix can vary considerably from one manufacturer to another. Differences in the amount of butterfat content and quantity and quality of other ingredients have a direct bearing on the finished frozen product. A change in machine performance that cannot be explained by a technical problem may be related to the mix.

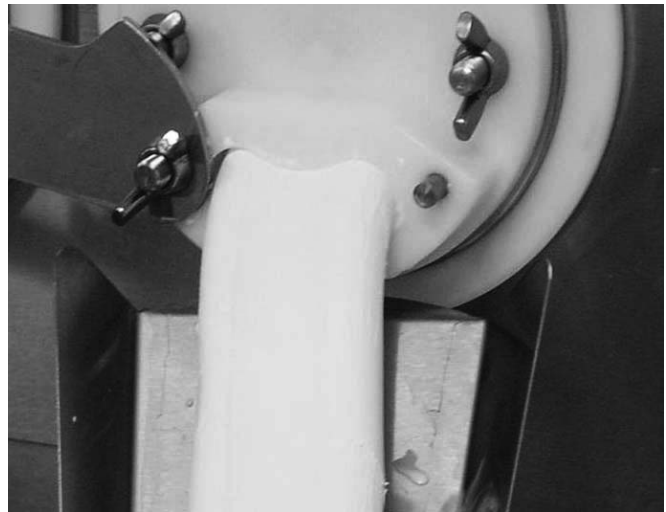

Figure 3-5 Proper Flow

Proper product serving temperature varies from one manufacturer's mix to another. When checking the temperature, stir the thermometer in the frozen product to read the true temperature.

Old mix or mix that has been stored at elevated temperatures will produce poor-quality product with a bad taste and unacceptable appearance. To retard bacteria growth in dairy based mixes, the best storage temperature range is between 36° to 41°F (2.2° to 5°C).

3.6 REMOVING MIX FROM MACHINE

To remove the mix from the machine, refer to the following steps. Make sure the gate on the faceplate is open.

- A. Press the PURGE/CLEAN button. The display will read PURGE.
- B. Press and hold the PURGE/CLEAN button for 3 seconds. The display will read CLEAN and a 20 minute timer will start.
- C. Open the flow control valve fully by turning the flow control knob clockwise until the pointer is near the 12:00 position.
- D. After the hopper and freezing cylinder have drained, place the Freezing Cylinder OFF-ON switch in the OFF position.

3.7 CLEANING THE MACHINE

NOTE

The frequency of cleaning the machine and machine parts must comply with local health regulations.

After the mix has been removed from the machine, the machine must be cleaned. To clean the machine, refer to the following steps:

- A. Place a container under the slide of the faceplate. Fill the hopper with 2 gallons (7.5 liters) of tap water.

- B. Place the Freezing Cylinder OFF-ON switch in the ON position. Press the PURGE/CLEAN button. The display will read PURGE.
 - C. Press and hold the PURGE/CLEAN button for 3 seconds. The display will read CLEAN and a 20 minute timer will start
 - D. When the water has drained, place the switch in the OFF position. Allow the freezing cylinder to drain completely.
 - E. Prepare detergent water by mixing 2 oz. of Palmolive detergent or equivalent in 2 gallons of 90° to 110°F (32° to 43°C) water. Repeat steps A through D using the detergent solution.
- A. Prepare detergent water by mixing 2 oz. of Palmolive detergent or equivalent in 2 gallons of 90° to 110°F (32° to 43°C) water.
 - B. Place all parts in detergent solution and clean with provided brushes.
 - C. Wash the hopper and freezing cylinder with the detergent water and brushes provided.
 - D. Wash the rear seal surfaces on the inside of the freezing cylinder with the detergent water.
 - E. Rinse all parts with clean 90° to 110°F (32° to 43°C) water.

NOTE

If the machine is not going to be immediately operated, store the faceplate in a clean and sanitized container in a cooler.

3.8 DISASSEMBLY OF MACHINE PARTS

Inspection for worn or broken parts should be made each time the machine is disassembled. All worn or broken parts should be replaced to ensure safety to both the operator and the customer and to maintain good machine performance and a quality product. Frequency of cleaning must comply with local health regulations.

To disassemble the machine, refer to the following steps:

 CAUTION
<p>Hazardous Moving Parts</p> <p>Revolving auger shaft can grab and cause injury. Place the Freezing Cylinder OFF-ON switch in the OFF position before disassembling for cleaning or servicing.</p>

- A. Remove the flow control rod and flow control valve from the hopper by pulling straight up.
- C. Remove the slide from the faceplate and remove the faceplate.
- D. Remove the front wear bushing.
- F. Remove the auger assembly from the machine. Pull the auger out of the freezing cylinder slowly. As the auger is being pulled out, carefully remove each of the blades and springs.
- G. Keep the rear of the auger shaft tipped up once it is clear of the machine to avoid dropping rear seal.
- H. Remove the rear seal.
- I. Wipe socket lubricant from the drive end (rear) of the auger with a cloth or paper towel.

3.9 CLEANING THE MACHINE PARTS

Place all loose parts in a pan or container and take to the wash sink for cleaning. To clean machine parts refer to the following steps:

3.10 ASSEMBLY OF MACHINE

To assemble the machine parts, refer to the following steps:

NOTE

Petrol Gel sanitary lubricant or equivalent must be used when lubrication of parts is specified.

NOTE

The United States Department of Agriculture and the Food and Drug Administration require that lubricants used on food processing equipment be certified for this use. Use lubricants only in accordance with the manufacturer's instructions.

- A. Install the rear seal onto the auger.
- B. Lubricate the auger drive (rear) with a small amount of spline lubricant. A small container of spline lubricant is shipped with the machine.
- C. Install two of the springs and auger blades onto the rear of the auger and insert part way into machine barrel. Rotate auger so another spring and blade can be placed onto the shaft.
- D. Install the remaining auger blades, push the auger into the machine barrel and rotate slowly until the auger engages the drive shaft (Fig. 3-6).



Figure 3-6 Installing Auger Blades



Figure 3-7 Install Front Wear Bushing

- E. Lubricate the inside and outside of the front wear bushing with Petrol Gel and install it onto the auger (Fig. 3-7).
- F. Install the large o-ring onto the faceplate and install the faceplate onto the machine.
- G. Install slide, hopper cover and drain tray.

3.11 ROUTINE CLEANING

To remove spilled or dried mix from the machine exterior, wash in the direction of the finish with warm soapy water and wipe dry. Do not use highly abrasive materials, as they will mar the finish.

3.12 PREVENTATIVE MAINTENANCE

It is recommended that a maintenance schedule be followed to keep the machine clean and operating properly.

A. DAILY

Disassemble and Clean

The frequency of cleaning the freezer and freezer parts must comply with local health regulations. Refer to the previous sections for proper disassembly and cleaning instructions.

Lubricate Front Wearguard

Petrol Gel sanitary lubricant or equivalent must be used when lubrication of parts is specified. Apply a thin film of sanitary lubricant to the inside and outside of the front wearguard.

Inspect Parts

Inspection for worn or broken parts should be made each time the freezer is disassembled. All worn or broken parts should be replaced to ensure safety to both the operator and the customer and to maintain good freezer performance and a quality

Lubricate Back End of the Auger

Lubricate the rear of the auger with a small amount of spline lubricant.

B. WEEKLY

Clean Inside Of Machine

Remove all side panels and clean the inside of the machine. Wipe any custard that may have dripped onto the inner panels with a damp soapy towel. Wash the drain tray.

C. MONTHLY

Clean Condenser Coils (And Filters If Applicable)

The coils on the hopper, dipping cabinet and remote condenser need to be cleaned to ensure proper airflow. Use compressed air to clean the condensers. Blow the air in the opposite direction of the normal airflow.

C. QUARTERLY

Replace Barrel Parts According To Schedule

Follow the Parts Replacement Schedule below to keep the freezer operating properly.

D. ANNUALLY

WARNING
<p>High voltage will shock, burn or cause death. Turn off and lock out main power disconnect before servicing. Do not operate machine with panels removed.</p>

Replace Barrel Parts

Follow the Parts Replacement Schedule below to keep the freezer operating properly.

Drive Belt Wear and Tension

Inspect the drive belts for wear. Check for wear marks from the belts rubbing on the pulley. Press firmly on the belts. When tension is properly adjusted, the belt will depress the approximate width of the belt with the pressure of a finger. If you think the belt is out of tension consult the Owner's Manual or contact Stoelting Customer Service.

Part	Description	3 Months	Annually	Qty per Barrel
C-2000-50	Spring		X	12
C-2000-51	Blade		X	12
SL-0010	Seal - Beater Shaft	X		1
149014	Bushing - Front Auger Support	X		1
625174	O-Ring - Front Door	X		1

Figure 3-8 Parts Replacement Schedule

E. CLEANING AND SANITIZING INFORMATION

Special consideration is required when it comes to food safety and proper cleaning and sanitizing.

The following information has been compiled by Purdy Products Company, makers of Stera-Sheen Green Label Cleaner/Sanitizer and specifically covers issues for cleaning and sanitizing frozen dessert machines. This information is meant to supplement a comprehensive food safety program.

SOIL MATERIALS ASSOCIATED WITH FROZEN DESSERT MACHINES

MILKFAT/BUTTERFAT – As components of ice-cream/frozen custard mix, these soils will accumulate on the interior surfaces of the machine and its parts. Fats are difficult to remove and help attribute to milkstone buildup.

MILKSTONE – Is a white/gray film that forms on equipment and utensils that come in contact with dairy products. These films will accumulate slowly on surfaces because of ineffective cleaning, use of hard water, or both. Milkstone is usually a porous deposit, which will harbor microbial contaminants and eventually defy sanitizing efforts.

Once milkstone has formed, it is very difficult to remove. Without using the correct product and procedure, it is nearly impossible to remove a thick layer of milkstone. (NOTE: general-purpose cleaners DO NOT remove milkstone.) This can lead to high bacteria counts and a food safety dilemma.

IT IS BEST TO CONTROL MILKSTONE ON A DAILY BASIS BEFORE IT CAN BECOME A SIGNIFICANT FOOD SAFETY PROBLEM.

In addition to food safety, milkstone can cause premature wear to machine parts which can add to costs for replacement parts or possibly more expensive repairs if worn machine parts are not replaced once they have become excessively worn.

IMPORTANT DIFFERENCES BETWEEN CLEANING AND SANITIZING

CLEANING vs. SANITIZING

It is important to distinguish between cleaning and sanitizing. Although these terms may sound synonymous, they are not. BOTH are required for adequate food safety and proper machine maintenance.

CLEANING

- Is the removal of soil materials from a surface.
- Is a prerequisite for effective sanitizing.

NOTE

An UNCLEAN surface will harbor bacteria that can defy sanitizing efforts.

Bacteria can develop and resist sanitizing efforts within a layer of soil material (milkstone). Thorough cleaning procedures that involve milkstone removal are critical for operators of frozen dessert machines.

SANITIZING

- Kills bacteria.
- Can be effective on clean surfaces only.

NOTE

Using a SANITIZER on an unclean surface will not guarantee a clean and safe frozen dessert machine.

PROPER DAILY MAINTENANCE: THE ONLY WAY TO ASSURE FOOD SAFETY AND PRODUCT QUALITY

Proper daily maintenance can involve a wide variety of products and procedures. Overall, the products and procedures fall into three separate categories. (Please note that this is a brief overview intended for informational purposes only.)

1. **CLEANING** – This involves draining mix from the machine barrel and rinsing the machine with water. Next, a cleaner is run through the machine. Then, the machine is disassembled and removable parts are taken to the sink for cleaning.
2. **MILKSTONE REMOVAL** – Since almost all cleaners do not have the ability to remove milkstone, the use of a delimer becomes necessary. Although this procedure may not be needed on a daily basis, it will usually follow the cleaning procedure. It requires letting a delimer solution soak in the machine for an extended period. Individual parts are also soaked in a deliming solution for an extended period (more about delimers in Additional Information).
3. **SANITIZING** – After the machine has been cleaned and contains no milkstone, the machine is reassembled. Then a FDA-approved sanitizing solution is run through the machine to kill bacteria. The machine is then ready for food preparation.

As a recommended cleaner and sanitizer for your frozen dessert machine, STERA-SHEEN has proven to be one of the best daily maintenance products for:

- **CLEANING** – Thorough removal of all solids including butterfat and milk fat.
- **MILKSTONE REMOVAL** – Complete removal of milkstone.
- **SANITIZING** – FDA-approved no rinse sanitizer for food contact surfaces.

ADDITIONAL INFORMATION

THE USE OF DELIMERS

A delimer is a strong acid that has the ability to dissolve milkstone. This type of chemical may become necessary once high levels of milkstone have developed. While these products are very effective for removing HIGH levels of milkstone, they are not ideal for two reasons:

1. **PRODUCT SAFETY** – Strong acids are dangerous chemicals and handling them requires safety

2. **MACHINE DAMAGE** – Strong acids will attack metal and rubber causing premature wear of parts. The use of a delimer needs to be closely monitored to avoid damage to machine surfaces and parts.

With proper daily use of STERA-SHEEN or its equivalent, there is no need for the use of a DELIMER.

DO NOT USE BLEACH

- **BLEACH HAS ABSOLUTELY NO CLEANING PROPERTIES.**
- **BLEACH IS CORROSIVE.** It can and will damage components of the machine causing premature wear and metal corrosion.

GENERAL PURPOSE CLEANERS

General purpose cleaners do not have the ability to remove milkstone. Milkstone will become a problem if not remedied with additional products and procedures.

THE USE OF CHLORINE TEST STRIPS

“Test strips” are used to determine concentrations of active chlorine in sanitizing solutions. To use the strips, tear off a small portion and submerge it into the sanitizing solution. Then, compare the color change to the color key on the side of the test strip dispenser to determine the approximate chlorine concentration.

The ideal concentration of chlorine needs to be 100 ppm (as stated by the FDA).

NOTE

Follow the directions on the container for proper concentration.

There are two main factors that contribute to falling chlorine concentrations in a sanitizing solution.

1. **PRODUCT USE** – As the chlorine in the solution is being used, chlorine concentrations fall.
2. **TIME** – As time passes, small amounts of chlorine “evaporate” from the solution. (That is why you can smell it.)

Sanitizing solutions should not be allowed to fall below 100 ppm chlorine. New solutions should be mixed once old solutions become ineffective.

3.13 EXTENDED STORAGE

Refer to the following steps for storage of the machine over any long shutdown period:

- A. Turn the Freezing Cylinder OFF-ON switch to the OFF position.
- B. Disconnect (unplug) from the electrical supply source.

- C. Clean thoroughly with a warm water detergent all parts that are exposed to the mix. Rinse in clean water and dry parts. Do not sanitize.

NOTE

Do not let the cleaning solution stand in the hopper or in the machine barrel during the shutdown period.

- D. Remove, disassemble and clean the faceplate, flow control assembly and auger parts. Place the auger blades and the front auger wear bushing in a plastic bag with a moist paper towel to prevent them from becoming brittle.

SECTION 4 TROUBLESHOOTING

4.1 ERROR CODES

When the machine experiences a problem, one of the following error codes will be displayed on the control panel. Each error code directs you to the system location of the malfunction.

ERROR CODE MALFUNCTION

1	Soft
2	High Torque
3	Extended Run Time
4	Clean
5	Barrel Sensor
6	Hopper Sensor
7	Drive Motor
8	Cab Sensor
9	High Pressure Cutout
10	Auxiliary Sensor
12	Hopper Sensor
13	Hopper Sensor

To return the machine to normal operation, any error causing condition must be corrected and the Freezing Cylinder Off/On switch must be placed in the OFF position and back in the ON position before the machine will return to normal operation.

4.2 TROUBLESHOOTING ERROR CODES

Error Code 1 - Soft Error

The Soft Error (E1) is an internal control board error that is logged for future analysis. The refrigeration is never stopped and the machine will continue to operate normally.

Error Code 2 - High Torque

If the control panel displays a High Torque Error (E2), the controller has sensed that the drive motor is running at 125% of the service factor amps (SFA) for 10 or more seconds. Place the Freezing Cylinder Off/On switch in the OFF position, wait until the product in the barrel thaws to a reasonably soft consistency and return the switch to the ON position. If the error persists, contact your Authorized Stoelting Distributor for further assistance.

Error Code 3 - Run Time

The Run Time Error (E3) occurs when the compressor runs continuously for 20 minutes. This error could happen if the cutout value is not attained during "Standby Mode" or if the "Ready" signal does not come on in "Custard Mode" or "Italian Ice Mode".

This error is generally caused by very low mix levels in the hopper or from product breakdown. Check the mix in the hopper. If the level mix is low, add mix. If there is a possibility that the mix has broken down, clean and sanitize the machine and replace the mix with fresh product.

Ice crystals in the hopper can clog the mix inlet system and prevent mix from entering the freezing cylinder. Thoroughly thaw mix per manufacturer's recommendations. To check for ice crystals, pour a small amount of product from the mix container through a clean and sanitized sieve or strainer. If ice crystals are in the mix, check temperature of the walk-in cooler where the mix is stored.

If the error persists after attempting to clear it, contact your Authorized Stoelting Distributor for further assistance.

Error Code 4 - Clean

If the machine is left in the Clean Mode for more than 10 minutes, the control panel will display a Clean Error (E4). This condition does not reflect a problem with the machine itself. The Clean Error has been programmed into the controller as a safeguard to protect the machine from potential damage caused by the machine being accidentally left in "Clean Mode". The control will attempt to restart itself after 5 minutes. The display will then flash and read Restart. To immediately clear the Clean Error, place the Freezing Cylinder Off/On switch in the OFF position and back in the ON position. After the Clean Error has been cleared, the machine will start a refrigeration cycle to protect the product in case the clean button was pressed by mistake.

Error Code 5 - Freezing Cylinder Sensor

The Freezing Cylinder Sensor Error (E5) indicates a failure of the barrel sensor or an extreme out of range condition (< -34°F or > 99°F). If the control panel displays an E5, place the Freezing Cylinder Off/On switch in the OFF position and back in the ON position. If the error persists, contact your Authorized Stoelting Distributor for further assistance.

NOTE

When the machine encounters a Freezing Cylinder Sensor Error, it will continue to run using preset timers. This mode will allow the freezing cylinder to continue making product until it can be serviced.

Error Code 6 - Hopper Sensor

The Hopper Sensor Error (E6) will not occur on a CC model machine.

Error Code 7 - Drive Motor

If the control panel displays a Drive Motor Error (E7), the control does not sense current coming from the drive motor. Place the Freezing Cylinder Off/On switch in the OFF position and back in the ON position. If the error persists, contact your Authorized Stoelting Distributor for further assistance.

Error Code 8 - Cab Sensor

A Cab Sensor Error (E8) will not occur on a CC model machine.

Error Code 9 - High Pressure Cutout

High Pressure Cutout Errors (E9) are usually caused by a dirty or inefficient condenser. If the control panel displays an E9 on an air cooled machine, check for proper air clearance around the condenser. In a water cooled machine, check that the water is not shut off. If the error persists, contact your Authorized Stoelting Distributor for further assistance.

Error Code 10 - Auxiliary Sensor

An Auxiliary Temperature Sensor Error (E10) occurs if the temperature sensor on the control board fails. Place the Freezing Cylinder Off/On switch in the OFF position and back in the ON position. If the error persists, contact your Authorized Stoelting Distributor for further assistance.

Error Code 12 - Right Hopper Sensor

The Right Hopper Sensor Error (E12) indicates a hopper temperature sensor failure. This error will also appear if the sensor is out of range. If the control panel displays an E12, place the Freezing Cylinder Off-On switch in the Off position and back in the On position. If the error persists, contact your Authorized Stoelting Distributor for further assistance.

Error Code 13 - Left Hopper Sensor

The Left Hopper Sensor Error (E13) indicates a hopper temperature sensor failure. This error will also appear if the sensor is out of range. If the control panel displays an E13, place the Freezing Cylinder Off-On switch in the Off position and back in the On position. If the error persists, contact your Authorized Stoelting Distributor for further assistance.

ALTERNATING FLASHING CONTROL PANEL LIGHTS

The display panel lights will flash in an alternating sequence under any error codes. Clear the error and place the Freezing Cylinder Off/On switch in the OFF position and back in the ON position.

4.3 TROUBLESHOOTING TABLES

PROBLEM	POSSIBLE CAUSE	REMEDY
Custard is running too cold or auger blades chatter during running.	<ol style="list-style-type: none"> 1 Flow is not high enough. 2 Hopper is low or out of mix. 3 Flow valve is plugged. 4 The refrigeration system is set too cold for the mix. 	<ol style="list-style-type: none"> 1 Increase the flow. Machine needs to run for at least a minute before you see a change in the product. 2 Add Mix 3 Check flow valve. 4 Call Stoelting service department and we can help over the phone to adjust setting properly.
Custard is running too soft.	<ol style="list-style-type: none"> 1 Flow is too high. 2 The refrigeration system for that barrel set too warm for the mix. 3 Condenser on remote unit is blocked. 4 Water cooled machine has water shut off. 5 Refrigeration system not functioning correctly. 	<ol style="list-style-type: none"> 1 Decrease the flow. Machine needs to run for at least a minute before you see a change in the product. 2 Call Stoelting service department and we can help over the phone to adjust setting properly. 3 Check for blockage and clean if necessary. 4 Check that water is connected and turned on. 5 Call Stoelting service department.
Beater motor freezes up in the run mode.	<ol style="list-style-type: none"> 1 Hopper is low or out of mix. 2 Flow valve is plugged. 3 Flow valve is set too low. 4 Belt is loose and slipping. 	<ol style="list-style-type: none"> 1 Add Mix 2 Check flow valve. 3 Increase the flow setting. 4 Check the belt and tighten if necessary.
Restriction of custard or lemon ice in the faceplate	<ol style="list-style-type: none"> 1 Restriction in the faceplate. 2 Solid obstruction in faceplate. 	<ol style="list-style-type: none"> 1 Use the rake to free the restriction and increase the flow rate setting by about 0.5. After a minute, repeat these steps if no results are seen. 2 Inspect the flow valve for solid custard or lemon pulp obstruction in the hopper.

SECTION 5 REPLACEMENT PARTS

5.1 DECALS AND LUBRICATION

Part	Description	Quantity
BR-0020	Brush - Tubing (1/2")	1
BR-0030	Brush - Head (Barrel)	1
BR-0035	Brush - Handle (Barrel)	1
C-1000-25F	Decal - Caution 100 Degree	2
C-1000-25I	Decal - L.H. Barrel	1
C-1000-25J	Decal - Center Barrel	1
C-1000-25K	Decal - R.H. Barrel	1
C-1000-26C	Decal - Made In USA	1
C-2000-57	Wrench - Beater Shaft	1
C74	O-Ring Pick	1
236058	Card - Cleaning Instruction	1
244138	Caster - Non-Locking (4") (Each)	2
244139	Caster - Locking (4") (Each)	2
324105	Decal - Caution Electrical Shock	-
324106	Decal - Caution Electrical Wiring Materials	-
324141	Decal - Caution Rotating Blades	-
324208	Decal - Attention Refrigerant Leak Check	-
324346	Decal - Caution Hazardous Moving Parts	-
324509	Decal - Cleaning Instructions	-
324566	Decal - Wired According To	-
324594	Decal - Attention Heat Sensitive	2
324686	Decal - Danger Automatic Start	2
324890	Decal - Hopper Off	1
324894	Decal - Flow Control	1 per barrel
324900	Decal - Safety Warning Alert	1
490760	Leg	4
508048	Lubricant - Spline (2 oz Squeeze Tube)	1
508135	Petrol Gel - 4 oz Tube	1

5.2 AUGER SHAFT AND FACEPLATE PARTS

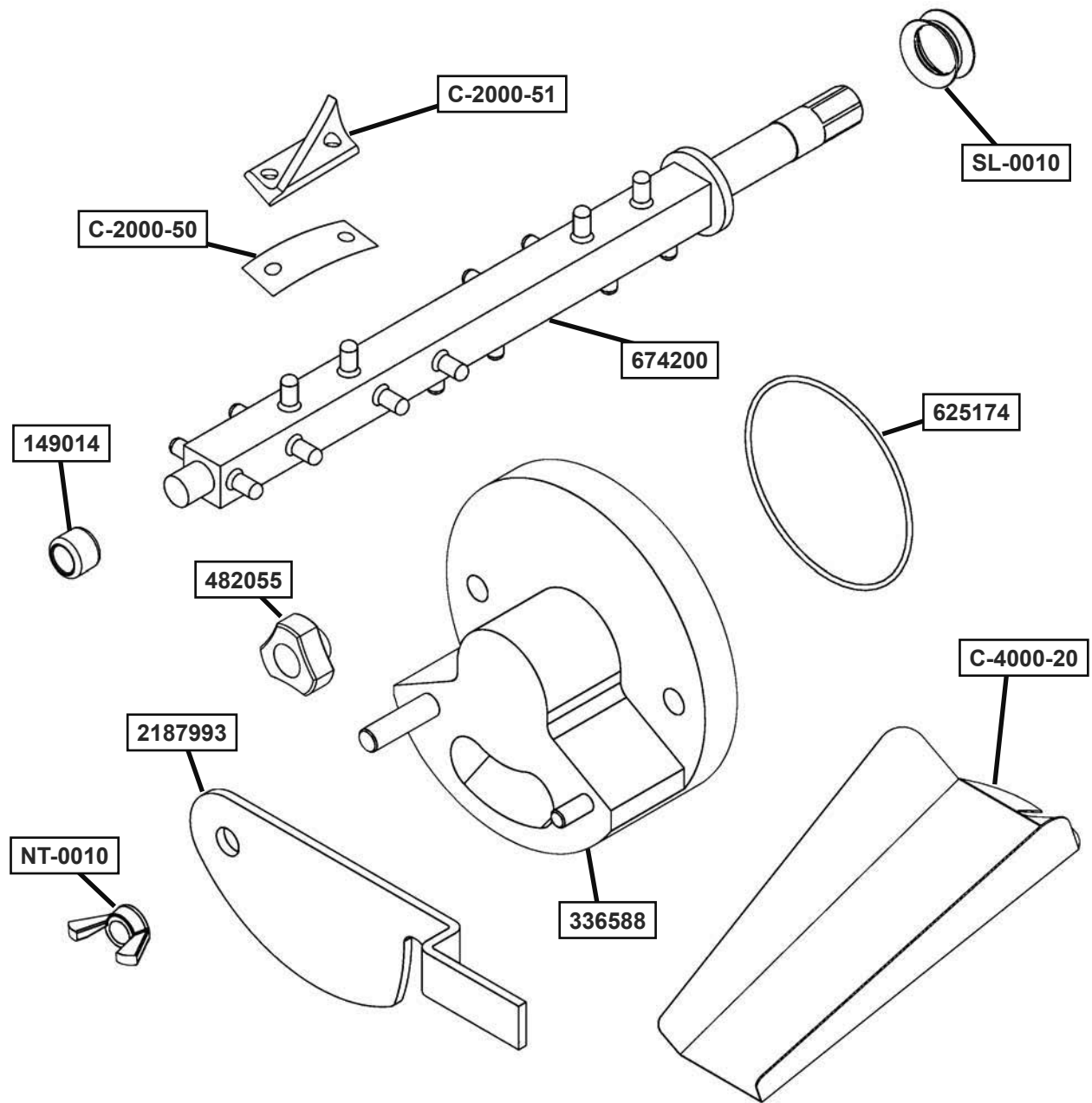

Part	Description	Quantity
C-2000-50	Spring	12 per barrel
C-2000-51	Blade	12 per barrel
C-4000-14	Guard Splash	1
C-4000-19	Slide - Long (Chute)	1
C-4000-20	Slide - Short (Chute)	1
NT-0010	Wing Nut - Stainless Steel	1 per barrel
SL-0010	Seal - Beater Shaft	1 per barrel
149014	Bushing - Front Auger Support	1 per barrel
336588	Face Plate	1 per barrel
482055	Knob - Front Door (Stainless)	2 per barrel
625174	O-Ring - Front Door - Red	1 per barrel
674200	Auger Shaft	1 per barrel
2187993	Gate - Front	1 per barrel

5.1 HOPPER PARTS

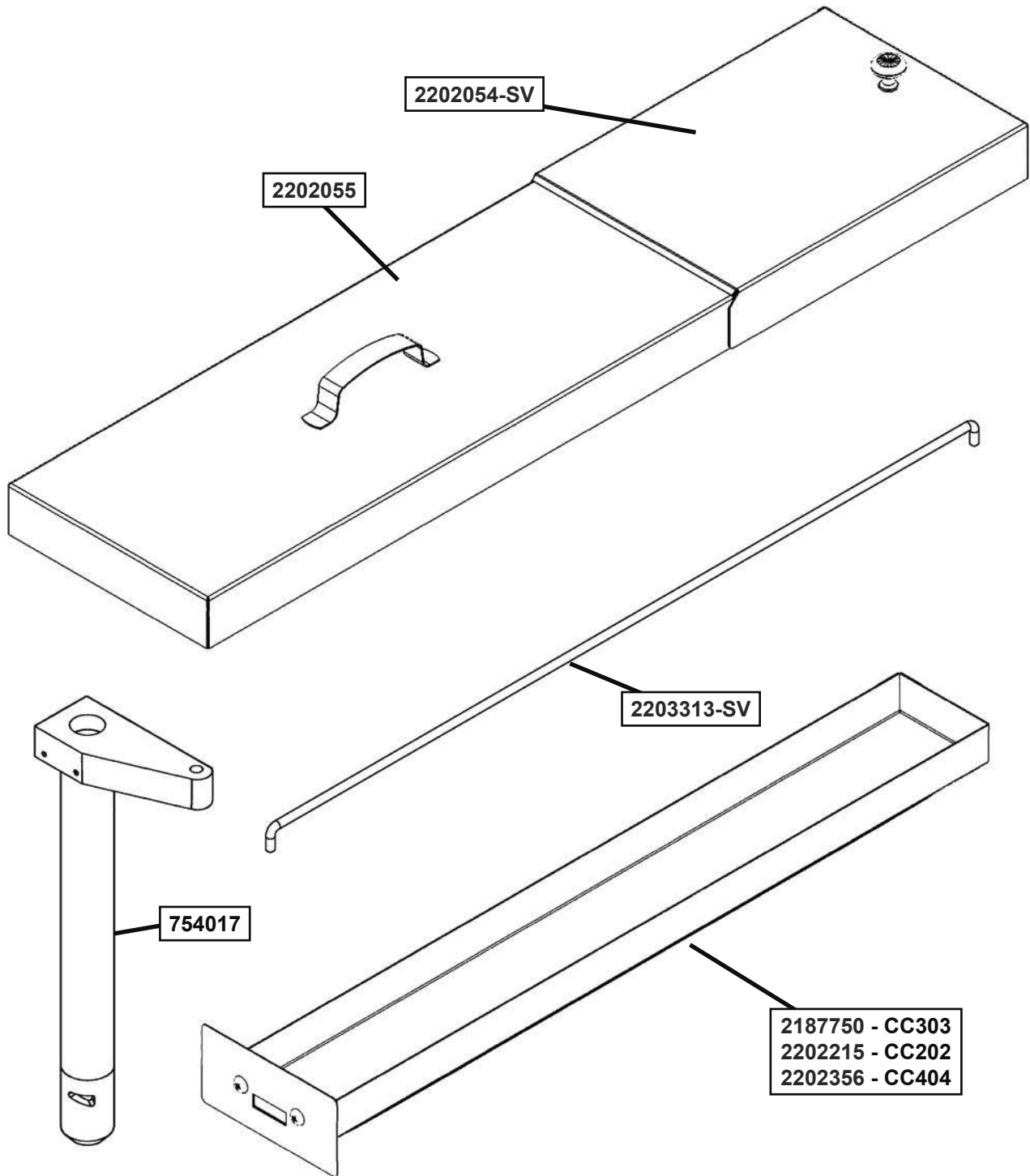

Part	Description	Quantity
754017	Tube - Flow Control (Hopper)	1 per barrel
2187750	Tray - Drain (CC303)	1
2202054-SV	Cover - Rear (Hopper)	1 per barrel
2202055	Cover - Front (Hopper)	1 per barrel
2202215	Tray - Drain (CC202)	1
2202356	Tray - Drain (CC404)	1
2203313-SV	Flow Control Rod	1 per barrel



**WARRANTY
CUSTARD EQUIPMENT AND BATCH EQUIPMENT**

1. **Scope:**
PW Stoelting, L.L.C. (“Stoelting”) warrants to the first user (the “Buyer”) that the freezing cylinders, hoppers, compressors, drive motors, speed reducers, beaters, and auger shafts of Stoelting custard equipment and batch equipment will be free from defects in materials and workmanship under normal use and proper maintenance appearing within two (2) years, and that all other components of such equipment manufactured by Stoelting will be free from defects in material and workmanship under normal use and proper maintenance appearing within twelve (12) months after the date that such equipment is originally installed.

2. **Disclaimer of Other Warranties:**

THIS WARRANTY IS EXCLUSIVE; AND STOELTING HEREBY DISCLAIMS ANY IMPLIED WARRANTY OF MERCHANTABILITY OR FITNESS FOR PARTICULAR PURPOSE.

3. **Remedies:**
Stoelting’s sole obligations, and Buyer’s sole remedies, for any breach of this warranty shall be the repair or (at Stoelting’s option) replacement of the affected component at Stoelting’s plant in Kiel, Wisconsin, or (again, at Stoelting’s option) refund of the purchase price of the affected equipment, and, during the first twelve (12) months of the warranty period, deinstallation/reinstallation of the affected component from/into the equipment. Those obligations/remedies are subject to the conditions that Buyer (a) signs and returns to Stoelting, upon installation, the Start-Up and Training Checklist for the affected equipment, (b) gives Stoelting prompt written notice of any claimed breach of warranty within the applicable warranty period, and (c) delivers the affected equipment to Stoelting or its designated service location, in its original packaging/crating, also within that period. Buyer shall bear the cost and risk of shipping to and from Stoelting’s plant or designated service location.

4. **Exclusions and Limitations:**
This warranty does not extend to parts, sometimes called “wear parts”, which are generally expected to deteriorate and to require replacement as equipment is used, including as examples but not intended to be limited to o-rings, auger seals, auger support bushings, and drive belts. All such parts are sold

AS IS.

Further, Stoelting shall not be responsible to provide any remedy under this warranty with respect to any component that fails by reason of negligence, abnormal use, misuse or abuse, use with parts or equipment not manufactured or supplied by Stoelting, or damage in transit.

THE REMEDIES SET FORTH IN THIS WARRANTY SHALL BE THE SOLE LIABILITY STOELTING AND THE EXCLUSIVE REMEDY OF BUYER WITH RESPECT TO EQUIPMENT SUPPLIED BY STOELTING; AND IN NO EVENT SHALL STOELTING BE LIABLE FOR ANY INCIDENTAL OR CONSEQUENTIAL DAMAGES, WHETHER FOR BREACH OF WARRANTY OR OTHER CONTRACT BREACH, NEGLIGENCE OR OTHER TORT, OR ON ANY STRICT LIABILITY THEORY.