



Model E122 / F122
OPERATORS MANUAL

Manual No. 513667

Rev.3

This manual provides basic information about the machine. Instructions and suggestions are given covering its operation and care.

The illustrations and specifications are not binding in detail. We reserve the right to make changes to the machine without notice, and without incurring any obligation to modify or provide new parts for machines built prior to date of change.

DO NOT ATTEMPT to operate the machine until instructions and safety precautions in this manual are read completely and are thoroughly understood. If problems develop or questions arise in connection with installation, operation, or servicing of the machine, contact Stoelting.



stoeltingfoodservice.com

Stoelting Foodservice Equipment
502 Highway 67
Kiel, WI 53042-1600
U.S.A.

Main Tel: 800.558.5807
Fax: 920.894.7029

Customer Service: 888.429.5920
Fax: 800.545.0662
Email: foodservice@stoelting.com

© 2014 PW Stoelting, LLC

A Few Words About Safety

Safety Information

Read and understand the entire manual before operating or maintaining Stoelting equipment.

This manual provides the operator with information for the safe operation and maintenance of Stoelting equipment. As with any machine, there are hazards associated with their operation. For this reason safety is emphasized throughout the manual. To highlight specific safety information, the following safety definitions are provided to assist the reader.

The purpose of safety symbols is to attract your attention to possible dangers. The safety symbols, and their explanations, deserve your careful attention and understanding. The safety warnings do not by themselves eliminate any danger. The instructions or warnings they give are not substitutes for proper accident prevention measures.

If you need to replace a part, use genuine Stoelting parts with the correct part number or an equivalent part. We strongly recommend that you do not use replacement parts of inferior quality.



Safety Alert Symbol:

This symbol Indicates danger, warning or caution. Attention is required in order to avoid serious personal injury. The message that follows the symbol contains important information about safety.

Signal Word:

Signal words are distinctive words used throughout this manual that alert the reader to the existence and relative degree of a hazard.



The signal word “WARNING” indicates a potentially hazardous situation, which, if not avoided, may result in death or serious injury and equipment/property damage.



The signal word “CAUTION” indicates a potentially hazardous situation, which, if not avoided, may result in minor or moderate injury and equipment/property damage.

CAUTION

The signal word “CAUTION” not preceded by the safety alert symbol indicates a potentially hazardous situation, which, if not avoided, may result in equipment/property damage.

NOTE (or NOTICE)

The signal word “NOTICE” indicates information or procedures that relate directly or indirectly to the safety of personnel or equipment/property.

TABLE OF CONTENTS

Section	Description	Page
1	Description and Specifications	
1.1	Description.....	1
1.2	Specifications	2
2	Installation Instructions	
2.1	Safety Precautions	5
2.2	Shipment and Transit.....	5
2.3	Machine Installation.....	5
2.4	Auto Fill Pump Installation.....	6
2.5	IntelliTec2™ Setup.....	6
3	Initial Set-Up and Operation	
3.1	Operator's Safety Precautions	9
3.2	Operating Controls and Indicators	9
3.3	Removing Mix From Machine.....	10
3.4	Disassembly of Machine Parts	11
3.5	Cleaning and Sanitizing the Machine Parts.....	12
3.6	Assembly of Machine	12
3.7	Sanitizing	13
3.8	Freeze Down and Operation	14
3.9	Mix Information	14
3.10	Routine Cleaning	14
3.11	Preventive Maintenance	14
3.12	Extended Storage.....	16
4	Troubleshooting	
4.1	Error Codes	17
4.2	Troubleshooting - Error Codes	17
4.3	Troubleshooting - Machine	19
4.4	Troubleshooting - Autofill Pump.....	20
5	Replacement Parts	
5.1	Decals and Lubrication	21
5.2	Auger Shaft and Faceplate Parts	22
5.3	Hopper Parts	24
5.4	Auto Fill Parts	25
6	Special Applications	
6.1	Application of Stoelting F122 and Arctic Quake Non-Dairy Concentrate....	27
7	Warranty	
7.1	Warranty of Mix Transfer Pumps / Cocktail / Slush	31

SECTION 1

DESCRIPTION AND SPECIFICATIONS

1.1 DESCRIPTION

The Stoelting E122 & F122 countertop machines are gravity fed. The machines are equipped with fully automatic controls to provide a uniform product. This manual is designed to help qualified service personnel and operators with the installation, operation and maintenance of the Stoelting E122 & F122 gravity machines.

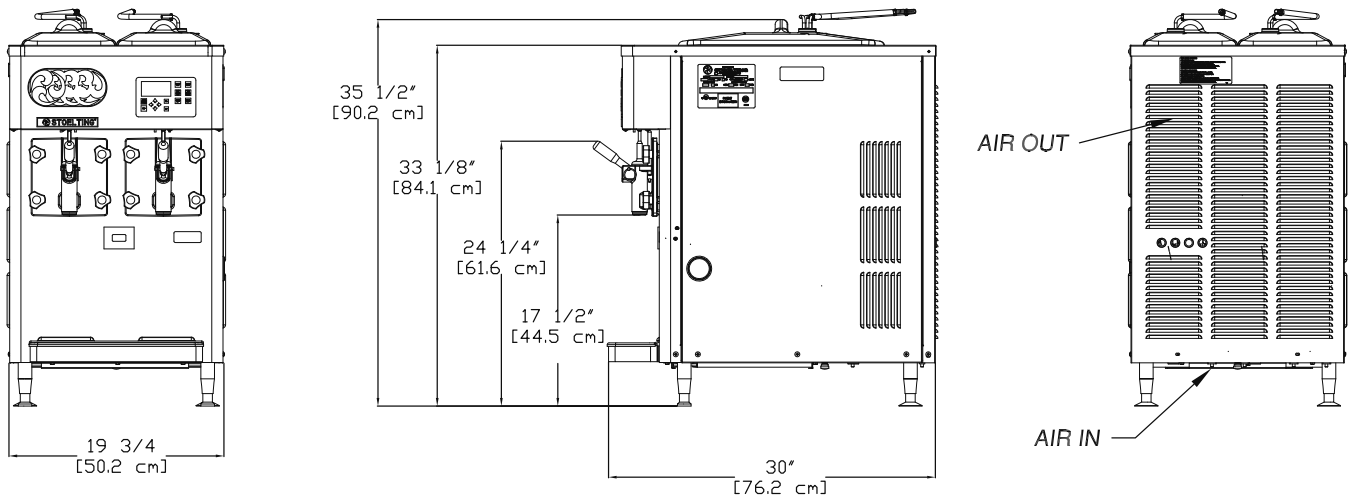

Figure 1-1 Model E122

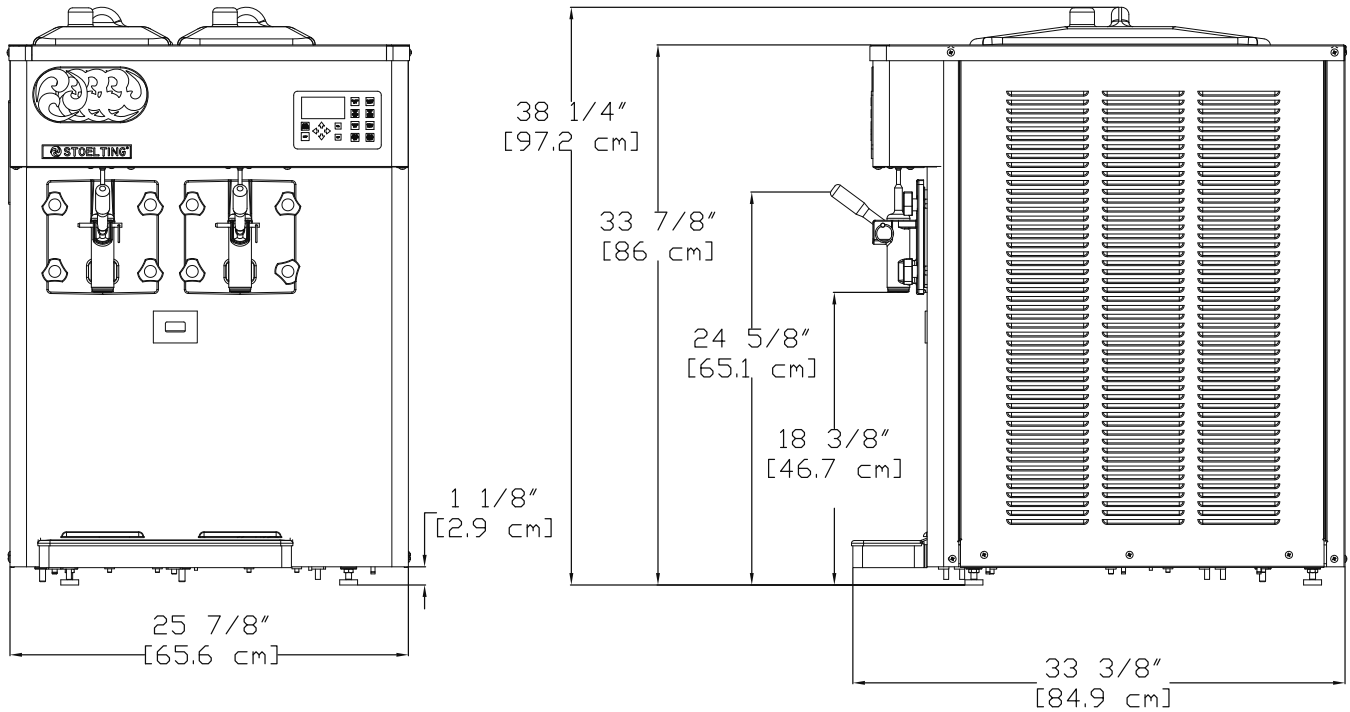

Figure 1-1 Model F122

1.2 SPECIFICATIONS



Model E122	
Dimensions	Machine
width	19-5/8" (49,8 cm)
height	35-1/2" (90,2 cm)
depth	30-1/4" (76,8 cm)
Electrical	1 Phase, 208-240 VAC, 60Hz
connection type	NEMA5-15P power cord provided
Compressor	5,500 Btu/hr
Drive Motor	Two - 1/3 hp
Air Flow	Air cooled units require 4" (10,2 cm) air space in back
Hopper Volume	Two - 3 gallon (11,36 liters)
Freezing Cylinder Volume	Two - 1.25 gallon (4,73 liters)



Model F122		
Dimensions	Machine	with crate
width	25-7/8" (65,7 cm)	31-3/4" (80,6 cm)
height	38-1/4" (97,2 cm)	47-3/8" (120,3 cm)
depth	33-3/8" (84,8 cm)	41-1/4" (104,8 cm)
Weight	390 lbs (176,9 kg)	485 lbs (219,9 kg)
Electrical	1 Phase, 208-240 VAC, 60Hz	
running amps	14.5A	
connection type	NEMA6-20P power cord provided	
Compressor	12,000 Btu/hr	
Drive Motor	Two - 1/2 hp	
Air Flow	Air cooled units require 6" (15,24 cm) air space on both sides	

SECTION 2 INSTALLATION INSTRUCTIONS

2.1 SAFETY PRECAUTIONS

Do not attempt to operate the machine until the safety precautions and operating instructions in this manual are read completely and are thoroughly understood.

Take notice of all warning labels on the machine. The labels have been put there to help maintain a safe working environment. The labels have been designed to withstand washing and cleaning. All labels must remain legible for the life of the machine. Labels should be checked periodically to be sure they can be recognized as warning labels.

If danger, warning or caution labels are needed, indicate the part number, type of label, location of label, and quantity required along with your address and mail to:

STOELTING
ATTENTION: Customer Service
502 Hwy. 67
Kiel, Wisconsin 53042

2.2 SHIPMENT AND TRANSIT

The machine has been assembled, operated and inspected at the factory. Upon arrival at the final destination, the entire machine must be checked for any damage which may have occurred during transit.

With the method of packaging used, the machine should arrive in excellent condition. **THE CARRIER IS RESPONSIBLE FOR ALL DAMAGE IN TRANSIT, WHETHER VISIBLE OR CONCEALED.** Do not pay the freight bill until the machine has been checked for damage. Have the carrier note any visible damage on the freight bill. If concealed damage and/or shortage is found later, advise the carrier within 10 days and request inspection. The customer must place claim for damages and/or shortages in shipment with the carrier. Stoelting cannot make any claims against the carrier.

2.3 MACHINE INSTALLATION

Installation of the machine involves moving the machine close to its permanent location, removing all crating, setting in place, assembling parts, and cleaning.

- A. Uncrate the machine.
- B. Determine the location of the machine. The location must be able to hold 470 lbs.
- C. Accurate leveling is necessary for correct drainage of the machine barrel and to insure correct overrun. Place a bubble level on top of the machine at each corner to check for level condition. If adjustment is necessary, level the machine by turning the bottom part of each leg in or out.



Figure 2-1 Space and Ventilation Requirements

- E. Correct ventilation is required. The machine requires 6" clearance on both sides for proper air flow.

CAUTION

Failure to provide adequate ventilation will void warranty.

- F. Connect the power cord to the proper power supply. Check the nameplate on your machine for proper supply. The unit must be connected to a properly grounded receptacle. The electrical cord furnished as part of the machine has a three prong grounding type plug. The use of an extension cord is not recommended, if necessary use one with a size 12 gauge or heavier with ground wire. Do not use an adapter to get around grounding requirement.

WARNING

Do not alter or deform electrical plug in any way. Altering the plug to fit into an outlet of different configuration may cause fire, risk of electrical shock, product damage and will void warranty.

2.4 AUTO FILL PUMP INSTALLATION

The auto fill pumps are powered by water and have a fixed orifice that delivers water and syrup to the machine at an exact ratio. The auto fill kit is designed for use with Bag In Box (BIB) concentrated syrup.

Follow these instructions to properly install the pump. Repeat for each side.

- Route the clear tubing with the BIB connector to the BIB. If there is excess tubing, trim it and reconnect it to the BIB connector.
- Route the water line tubing to the shutoff valve of the water supply. Trim excess tubing and connect it to the shutoff valve.
- Route the water line and syrup line tubing (3/8" braided tubing) from the pump to the machine.
- Route the water line tubing to the tube exiting the rear panel. Trim excess tubing and connect.
- Route the syrup line to the tubing connected to the adapter on the hopper cover. Trim excess tubing and connect.
- Check that the clear tubing coming out of the rear panel is connected to the plug in the hopper cover. If not, connect it using a clamp in the kit.
- Check that all tubing connections are properly clamped, fittings are tightened and the tubing is not kinked.

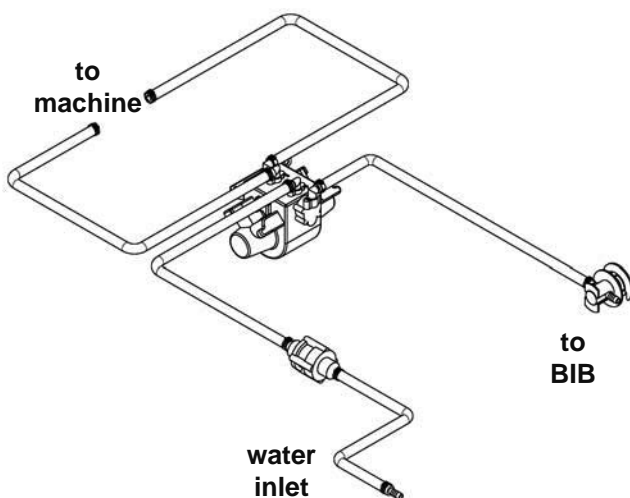

Figure 2-2 Auto Fill Pump Tubing Layout

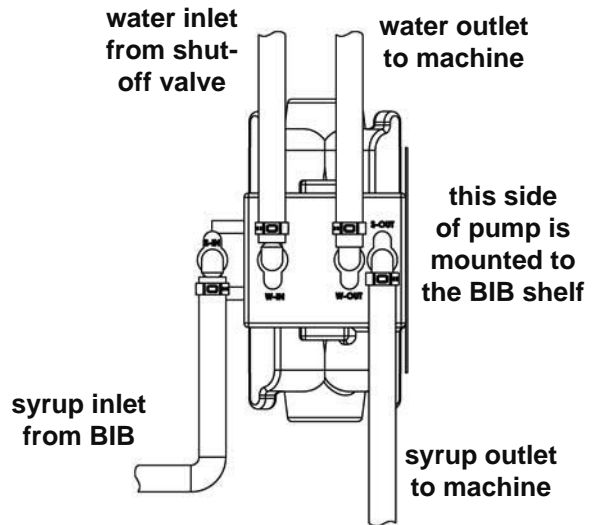

Figure 2-3 Top View of Pump

2.6 INTELLITEC2™ SETUP

PRIOR TO INSTALLATION

- Locate a copy of the service contact file (info.txt).
- Modify the info.txt file with information from the service company using the instructions in the file.
- Put the service contact file onto the root level of a USB flash drive (do not put the files into any folder).

SETTING MODEL INFORMATION

- Press the Main Power button.
- The display will ask if the machine is an E122 or F122. Use the arrow buttons to move the cursor to the correct model and press the SEL button.

SETTING CONTACT INFORMATION

- Plug your USB flash drive into the control if it is not already plugged in.
- From the Current Status screen, press the left arrow button to access the passcode selection screen. Press the right arrow, SET, and then the SEL button.
- After the password is accepted, use the arrows to move the cursor to the Modify Settings option and press the SEL button. Then move the cursor to the User Preferences and press the SEL button.

```

Modify Operating Settings
_ Reset Serve Amount
_ Basic Settings
_ Advanced Settings
_ Storage Settings
_ User Preferences
_ Time and Date
    
```

Figure 2-4

- D. On the User Preferences screen move the cursor to the Contact Information USB Update and press the SEL button.

```

User Preferences
_ Language                      English
_ Temp Units                    Farenheit(°F)
_ Service Contact Information
_ Contact Information USB Update
_ Samples Served Information
_ SSID Information USB Update
_ Pass Key USB Update
  
```

Figure 2-5

- E. The screen will change and show “File Found” for a quick second while it updates the information.
 F. After updating the contact information, the screen will show the Service Contact Information page.

```

Service Contact Information
Name
  Stoelting
Telephone Number
  920 - 894 - 2293
Unit Serial Number
  00000000
Version                      00.00/00.00
  
```

Figure 2-6

- G. Press the left arrow button to go back to the Current Status screen and remove the USB flash drive.

SETTING TIME AND DATE

- A. Press the right arrow button.
 B. Move the cursor to the Modify Settings option and press the SEL button. Then move the cursor to the Time and Date option and press the SEL button and adjust the settings as required.
1. Press the SEL button to enter the Modify Time and Date screen.
 2. Move the cursor to the setting that needs to be changed and press the SET button.
 3. Use the arrow buttons to change the setting and press the SET button to save the change.

```

Time and Date

Time                      00:00:00 AM
Date                      00/00/00
Daylight Savings          Off
Clock Type                12 HR
Date Format
_ Modify Time and Date
  
```

Figure 2-7

- C. Press the left arrow button until the Current Status screen is displayed.

SECTION 3 INITIAL SET-UP AND OPERATION

3.1 OPERATOR'S SAFETY PRECAUTIONS

SAFE OPERATION IS NO ACCIDENT; observe these rules:

- A. Know the machine. Read and understand the Operating Instructions.
- B. Notice all warning labels on the machine.
- C. Wear proper clothing. Avoid loose fitting garments, and remove watches, rings or jewelry that could cause a serious accident.
- D. Maintain a clean work area. Avoid accidents by cleaning up the area and keeping it clean.
- E. Stay alert at all times. Know which switch, push button or control you are about to use and what effect it is going to have.
- F. Disconnect electrical cord for maintenance. Never attempt to repair or perform maintenance on the machine until the main electrical power has been disconnected.
- G. Do not operate under unsafe operating conditions. Never operate the machine if unusual or excessive noise or vibration occurs.

3.2 OPERATING CONTROLS AND INDICATORS

Before operating the machine, it is required that the operator know the function of each operating control. Refer to Figure 3-1 for the location of the operating controls on the machine. For information regarding error codes displayed on the control panel, refer to the troubleshooting section of this manual.

WARNING

High voltage will shock, burn or cause death. Make sure the display shows the freezing cylinders and pump are off. If they are not, press the On/Off button and Pump button to turn them off prior to disassembling for cleaning or servicing. Do not operate machine with panels removed.

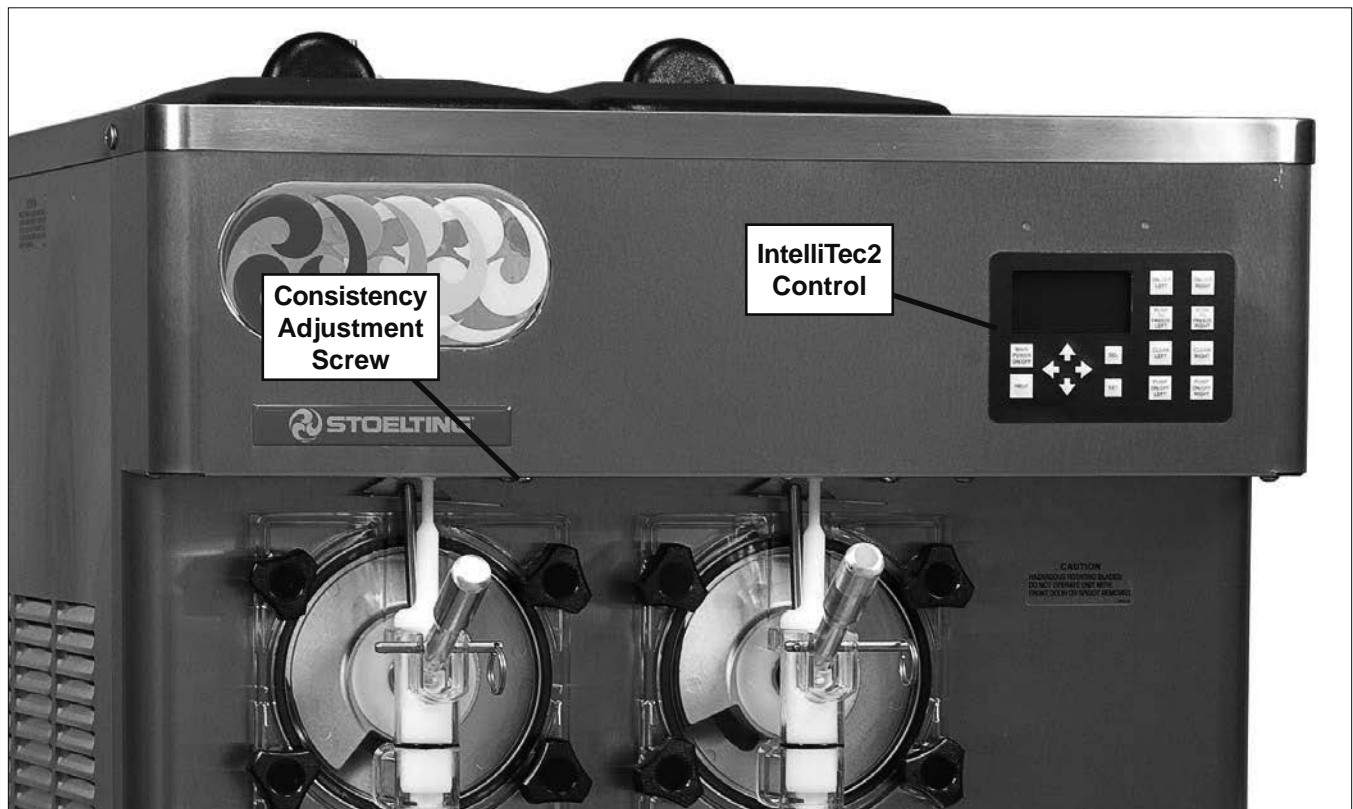

Figure 3-1 F122 Controls

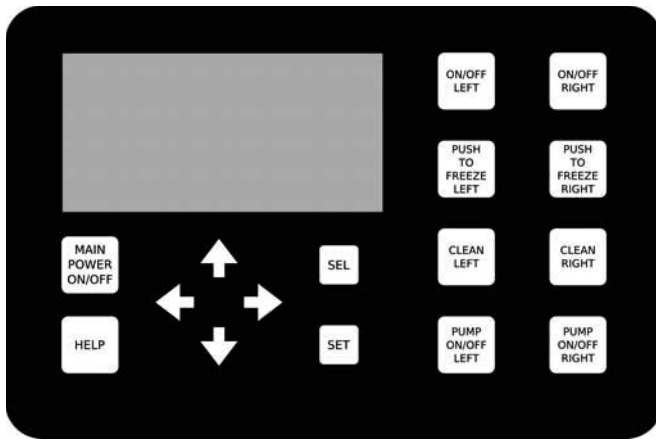

Figure 3-2 IntelliTec2 Control

A. INTELLITEC2 TOUCHPAD

Main Power On/Off

The Main Power button is used to supply power to the IntelliTec2 control, the freezing cylinder circuits and the storage refrigeration system. When the machine is first plugged in, the control defaults to the On status with power to the hoppers only. If the Main Power On/Off button is pressed when the machine is on, the machine will turn off and a status message will be displayed on the screen.

Help

Pressing the Help button will display help information dependant on the cursor's location. Pressing the Help button again will exit the help screen.

Selection Button (SEL)

The SEL button is used by service technicians to select menu options.

Set Button (SET)

The SET button is used by service technicians to save changes when modifying control settings.

On/Off Button

Power to the freezing cylinders is controlled with the On/Off Left and On/Off Right buttons.

Push to Freeze Button

Pressing the PUSH TO FREEZE button initiates "Serve Mode".

Clean Button

The CLEAN button initiates "Clean Mode".

Pump Button

The Pump On/Off buttons control power to the solenoids for the autofill system.

Arrow Buttons (←, ↑, →, ↓)

The arrow buttons are used by service technicians to navigate through the control readings and settings.

B. SPIGOT SWITCH

The spigot switch will automatically start the auger drive and refrigeration systems when the spigot is opened to dispense product. When the spigot is closed, the drive motor and compressor will remain on until the product in the freezing cylinder reaches the proper consistency.

C. CONSISTENCY ADJUSTMENT SCREW

The Consistency Adjustment Screw increases or decreases product consistency. A tension spring is connected to the screw and changes the amount of torque needed to complete a refrigeration cycle. Turn the knob clockwise to increase consistency or counterclockwise to decrease consistency.

C. HOPPER PROBES

The mix level in the hoppers is controlled by two probes. When mix in the hopper gets below the long probe, the autofill solenoid opens and the hopper fills. When the mix level reaches the short probe, the autofill solenoid closes.

3.3 REMOVING MIX FROM MACHINE

To remove the mix from the machine, refer to the following steps:

- A. Wash, rinse, dry and sanitize hands before starting.
- B. Press the Pump On/Off button to turn the autofill pump off.
- C. Make sure the display shows the freezing cylinder is off. If it is not, press the On/Off Left or On/Off Right button to turn it off.
- D. Press the Clean button and drain the mix from the freezer into a bucket. Once drained, stop the cleaning cycle by pressing the Clean button.
- E. Fill the hopper with 2 gallons of clean, cold water.
- F. Press the Clean button. Run the machine in Clean mode for approximately 5 minutes. Continue to the next step while the machine is cleaning.
- G. Prepare Stera-Sheen Green Label Sanitizer according to manufacturer's instructions to provide a 100ppm strength solution. In a clean bucket, mix 1 packet of sanitizer and 2 gallons of cold water. Check the chlorine content with a test strip to ensure 100ppm strength.
- H. After 5 minutes, drain the water from the machine into a bucket and discard the water. Press the Clean button to stop the cleaning cycle.

NOTE

If the water does not drain clear, repeat the steps.

- I. Fill the hopper with the 2 gallons of sanitizer solution.
- J. Press the clean button. Run the machine in Clean mode for approximately 5 minutes.

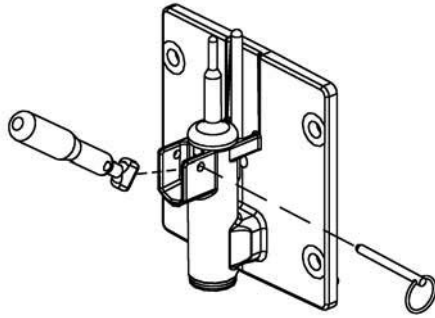

Figure 3-3 Remove Spigot Pin

- K. After 5 minutes, drain the sanitizer solution from the machine into a bucket and discard the solution.

3.4 DISASSEMBLY OF MACHINE PARTS

Inspect for worn or broken parts each time the machine is disassembled. Replace any worn or broken parts to ensure safety to both the operator and the customer and to maintain good machine performance and a quality product. Frequency of cleaning must comply with the local health regulations.

To disassemble the machine, refer to the following steps:

! WARNING

High voltage will shock, burn or cause death. Make sure the display shows the freezing cylinders and pump are off. If they are not, press the On/Off button and Pump button to turn them off prior to disassembling for cleaning or servicing. Do not operate machine with panels removed.

- A. Pull out the spigot pin by its ring. Remove the spigot handle.

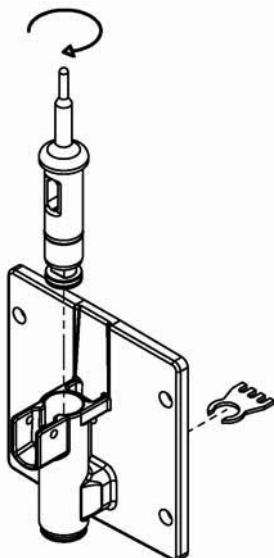

Figure 3-4 Spigot and Ice Breaker Bar Removal



Figure 3-5 Removing O-Ring

- B. Remove front door by turning the circular knobs and then pulling door off the studs.

NOTE

When removing front door, entire door and stator assembly will come out as well.

- C. Remove the torque rod from the stator assembly.
- D. Remove the quad ring from the groove in front door.
- E. Remove the stator bar. Remove the small white bushing.
- F. Remove the o-rings at the front and back of the stator bar by first wiping off the lubricant using a clean paper towel. Then squeeze the o-ring upward with a dry cloth. When a loop is formed, roll the o-ring out of the groove.
- G. Remove the auger support bushing.
- H. Turn the spigot body until the ice breaker bar can be removed. Remove breaker bar.
- I. Remove the spigot body from the front door.
- J. Remove the o-rings (2) from the spigot.
- K. Remove the auger assembly from the freezing cylinder and remove the auger blade. Remove the rear seal and o-ring from the auger.
- L. Remove the drain tray, drip tray and drip tray grid.
- M. Remove the hopper cover and disconnect the autofill adapter from the cover by pulling out the retaining clip.

3.5 CLEANING AND SANITIZING THE MACHINE PARTS

Place all loose parts in a pan or container and take to the wash sink for cleaning. Local and state health codes dictate the procedure required. Some health codes require a four-sink process (pre-wash, wash, rinse, sanitize, and air-dry), while other codes require a three-sink process (without the pre-wash step). The following procedures are a general guideline only. Consult your local and state health codes for procedures required in your location.

- A. Set up a 3-compartment sink with wash, rinse and sanitize compartments. Use Stera-Sheen Green Label or equivalent. Prepare sanitizer according to manufacturer's instructions to provide a 100ppm strength solution. Set aside a small amount of sanitizer
- B. Clean all parts using brushes provided.
- C. After cleaning, remove the parts and let air dry.
- D. Sanitize the hopper and freezing cylinder with sanitizer. Be sure to clean the rear seal surfaces inside the freezing cylinder.
- E. Wipe down the outside of the machine and table with a yellow sanitized towel.

CAUTION
Do not allow sanitizer to remain in contact with stainless steel parts for prolonged periods. Prolonged contact of sanitizer with machine may cause corrosion of stainless steel parts.

3.6 ASSEMBLY OF MACHINE

To assemble the machine parts, refer to the following steps:

NOTE

Petrol Gel sanitary lubricant or equivalent must be used when lubrication of parts is specified.

NOTE

The United States Department of Agriculture and the Food and Drug Administration require that lubricants used on food processing equipment be certified for this use. Use lubricants only in accordance with the manufacturer's instructions.

- A. Wash, rinse, dry and sanitize hands before starting.
- B. Place the rear seal o-ring onto the auger and apply a thin film of Petrol-Gel to the o-ring.
- C. Assemble the rear seal onto the auger with the large end of the seal to the rear. Lubricate the hex end of the auger with a small amount of spline lubricant.
- D. Install the plastic auger blade onto the auger. Push the auger into the freezing cylinder and rotate it slowly until the auger engages the drive shaft.
- E. Assemble the o-rings onto the spigot body and apply a thin film of Petrol-Gel onto the o-rings.
- F. Insert the spigot body into the front door.

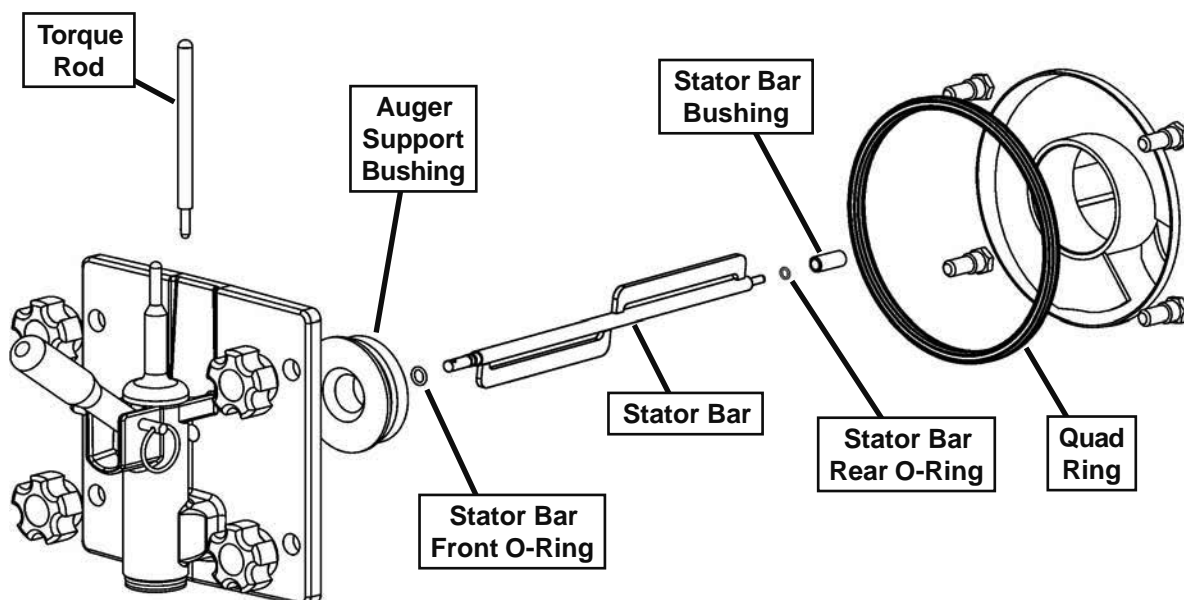

Figure 3-6 Door and Stator Assembly

NOTE

When inserting the spigot body, press the o-rings against the spigot to prevent damage.

- G. Turn the spigot body until the ice breaker bar can be inserted. Insert the ice breaker bar and rotate spigot body 90°.
- H. Apply Petrol-Gel to the inside and outside of the front auger support bushing. Install the bushing onto the front door so the beveled edge of the bushing is against the door.
- I. Install the large quad ring into the groove in the front door.
- J. Install the o-rings at the front and back of the stator bar. Apply a thin film of Petrol-Gel onto the o-rings. Install the small white bushing to the stator bar.
- K. Insert the stator bar into the front door and insert the torque rod through the hole in the stator bar.
- L. Install the front door onto the freezer. Install the knobs onto the studs.

NOTE

When installing the front door, the torque rod must be placed in the center notch of the torque actuator arm.

- M. Insert the spigot handle so the hole lines up and insert the spigot pin.
- N. Install the drain tray, drip tray and drip tray grid.

3.7 SANITIZING

Sanitizing must be done after the machine is cleaned and just before the hopper is filled with mix. Sanitizing the night before is not effective. However, you should always clean the machine and parts after each use.

The United States Department of Agriculture and the Food and Drug Administration require that all cleaning and sanitizing solutions used with food processing equipment be certified for this use.

When sanitizing the machine, refer to local sanitary regulations for applicable codes and recommended sanitizing products and procedures. The frequency of sanitizing must comply with local health regulations.

Mix sanitizer according to manufacturer's instructions to provide a 100 parts per million (ppm) strength solution and check the solution with chlorine test strips. Mix sanitizer in quantities of no less than 2 gallons (7.5 liters) of 90° to 110°F (32° to 43°C) water. Allow sanitizer to contact the surfaces to be sanitized for 5 minutes. Any sanitizer must be used only in accordance with the manufacturer's instructions.

In general, sanitizing may be conducted as follows:

CAUTION
Do not allow sanitizer to remain in contact with stainless steel parts for prolonged periods. Prolonged contact of sanitizer with machine may cause corrosion of stainless steel parts.

- A. Prepare Stera-Sheen Green Label Sanitizer or equivalent according to manufacturer's instructions to provide a 100ppm strength solution. In a clean bucket, mix 1 packet of sanitizer and 2 gallons of cold water. Check the chlorine content with a test strip to ensure 100ppm strength.
- B. Pour the sanitizing solution into the hopper.
- C. Press the Main Power On/Off button and press the Clean button to start the cleaning cycle.
- D. Use a sanitized barrel brush to sanitize the hopper sides and hopper cover with the sanitizer solution in the hopper.
- E. After 5 minutes, drain the sanitizer solution from the machine into a bucket and discard the solution. Leave a small amount of sanitizer solution in the freezing cylinder.
- F. Place Clean button to stop the cleaning cycle.
- G. Collect the remaining sanitizer in a clean cup and check the chlorine content with a test strip. If the chlorine content is less than 100ppm, repeat the sanitizing procedure. If the test strip does not read 100ppm after the second test, repeat the disassembly, cleaning and sanitizing procedures.
- H. Connect the autofill adapter to the hopper cover with the retaining clip and place the hopper cover onto the hopper.
- I. Press the Pump On/Off button to turn the pump on.
- J. Press the Push to Freeze button to start the freezing cycle. Open the spigot to drain out any remaining sanitizer into the a bucket. Close the spigot when mix begins coming out.

3.8 FREEZE DOWN AND OPERATION

- A. After the freezing cylinder is filled, product will be ready to serve in 8 to 12 minutes.
- B. To dispense, pull the spigot handle down to open the spigot.
- C. The machine is designed to dispense the product at a reasonable draw rate. If the machine is overdrawn, the result is a wet product or a product that will not dispense at all. If this should occur, allow the machine to run for approximately 30 seconds before dispensing additional product.
- D. Do not operate the machine when the LOW MIX message is displayed. Immediately check if the autofill system is operating properly.

3.9 MIX INFORMATION

Mix can vary considerably from one manufacturer to another. Differences in the quantity and quality of ingredients have a direct bearing on the finished frozen product. A change in machine performance that cannot be explained by a technical problem may be related to the mix.

3.10 ROUTINE CLEANING

To remove spilled or dried mix from the machine exterior, wash in the direction of the finish with warm soapy water and wipe dry. Do not use highly abrasive materials as they will mar the finish.

3.11 PREVENTIVE MAINTENANCE

Stoelting recommends that a maintenance schedule be followed to keep the machine clean and operating properly.

B. DAILY

- 1. The exterior should be kept clean at all times to preserve the luster of the stainless steel. A mild alkaline cleaner is recommended. Use a soft cloth or sponge to apply the cleaner.

C. WEEKLY

- 1. Check o-rings and rear seal for excessive wear and replace if necessary.
- 2. Remove the drip tray by gently lifting up to disengage from the support and pulling out. Clean behind the drip tray and front of the machine.

D. QUARTERLY

The air-cooled condenser is a copper tube and aluminum fin type. Condensing is totally dependent upon airflow. A plugged condenser filter, condenser, or restrictions in the louvered panel will restrict airflow. This will lower the capacity of the system and damage the compressor.

The condenser must be kept clean of dirt and grease. The machine must have a minimum of 6" (15.2 cm) of ventilation on both sides of the unit for free flow of air.

The condenser and condenser filter require periodic cleaning. To clean, refer to the following procedures.

E122 Air Cooled Condenser Cleaning

- A. Partially unscrew the knob located on the underside of the machine. The knob holds the filter bracket which does not need to be detached to remove the filter.
- B. Remove the filter.
- C. Visually inspect the condenser filter for dirt.
- D. If the filter is dirty, vacuum or brush clean, rinse with clean water and allow to dry before replacing on the machine.

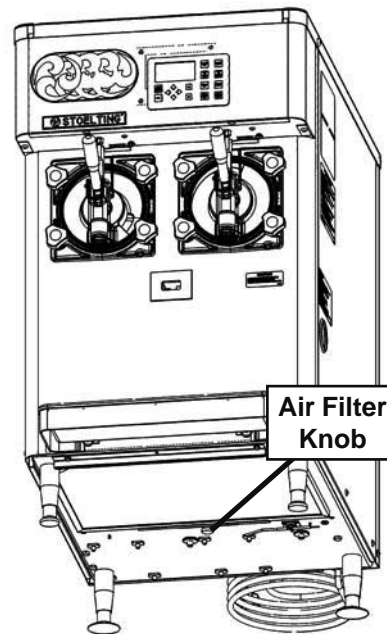

Figure 3-7 E122 Condenser Filter Removal



Figure 3-8 F122 Condenser Filter Removal

F122 Air Cooled Condenser Cleaning

- A. Remove the Phillips head screws from the right side panel, and then remove the panel.
- B. To remove the condenser filter, grasp the top and pull off. Visually inspect for dirt. If the filter is dirty, shake or brush excess dirt off the filter and wash in warm, soapy water. Once the filter is clean rinse thoroughly in warm, clear water and shake dry, taking care not to damage the filter in any way.
- C. Visually inspect the condenser for dirt by shining a light through the coil from the back (inside) of the condenser.
- D. If the condenser is dirty, place a wet towel over the front (outside) of the condenser.
- E. Using a vacuum, carefully clean the condenser coil from the inside and outside of the machine. A stiff bristled brush may help in releasing debris from between the condenser coils.

E. SEMI-ANNUALLY

1. Disconnect the machine from the power source.
2. Check drive belt for proper tension. Push belt in with one finger, belt should deflect about 3/8".
3. Lubricate condenser fan motor with S.A.E. 20 weight oil. Three to six drops is required.
4. Sanitize the autofill system following the steps below:

AUTOFILL SANITIZING

- A. If necessary, disassemble, clean and sanitize the machine.

NOTE

If the machine does not require cleaning and sanitizing, press the Pump On/Off button to turn off the pump. Then dispense enough product so that the mix level in the hopper is below the long probe. If the mix level is above the long probe, the solenoid will not activate and the pump will not operate.

- B. Prepare Stera-Sheen Green Label Sanitizer or equivalent according to manufacturer's instructions to provide a 100ppm strength solution. Mix the sanitizer in quantities of no less than 2 gallons of 90° to 110°F (32° to 43°C) water. Any sanitizer must be used only in accordance with the manufacturer's instructions.
- C. Cut an adapter from an empty bag of syrup. Connect the adapter to the BIB connector of the syrup line. Put the BIB connector into the bucket of sanitizer.

NOTE

If you do not have an empty bag of syrup, remove the plug from the top of the BIB connector. Do not lose the plug; it is needed for proper operation of the BIB.

- D. Make sure the display screen shows that the main power is on. Hold the hopper cover over a bucket and press the Pump On/Off button. The solenoid will activate and the brix pump will pump sanitizer into the bucket.

NOTE

The solenoid will only activate when there is not any liquid touching the longer mix probe in the hopper.

- E. After all the sanitizer has run through the pump, press the Pump On/Off button to turn off the pump.
- F. Disconnect the bag adapter from the BIB connector (or reinsert the plug into the connector). Connect the BIB connector to the syrup BIB.
- G. Hold the hopper cover over a bucket and press the Pump On/Off button. This will flush the sanitizer out of the pump and tubing. Once the sanitizer is flushed out, press the Pump On/Off button.
- H. The pump is now ready to operate. Place the hopper cover on the hopper.

3.12 EXTENDED STORAGE

Refer to the following steps for storage of the machine over any long period of shutdown time:

- A. Follow the cleaning and sanitizing procedures for the machine and follow the semi-annual instructions to sanitize the autofill system.
- B. Press the Main Power On/Off button so that power to the machine is off.
- C. Disconnect (unplug) from the electrical supply source.
- D. Thoroughly clean all parts that come in contact with mix. Rinse in clean water and dry parts. Do not sanitize.

NOTE

Do not leave cleaning solution in the hopper or in the freezing cylinder during the shutdown period.

- E. Remove, disassemble and clean the front door, mix inlet regulator and auger parts.

SECTION 4 TROUBLESHOOTING

4.1 ERROR CODES

When the machine experiences a problem, one of the following error codes will be displayed on the control panel. Each error code directs you to the system location of the malfunction.

ERROR CODE MALFUNCTION

2	High Torque
3	Run Time
4	Clean
5	Freezing Cylinder Sensor
6	Hopper Sensor (single hopper machines)
7	Drive Motor
8	Cab Sensor
9	High Pressure Cutout
10	Auxiliary Sensor
11	Prime (cab units only)
12	Left Hopper Sensor
13	Right Hopper Sensor
21	Spigot Open Time

To return the machine to normal operation, any error causing condition must be corrected and the power to the affected freezing cylinder must be cycled. Turn the power to the freezing cylinder off then back on using the On/Off button of the affected freezing cylinder.

4.2 TROUBLESHOOTING ERROR CODES

Error Code 2 - High Torque

If the control panel displays a High Torque Error (E2), the controller has sensed that the drive motor is running at a high load for 10 or more seconds. This may be due to the product consistency adjustment being set too high. Press the On/Off button for the cylinder to turn it off, wait until the product in the freezing cylinder thaws and then turn the cylinder back on. If the error persists, contact your Authorized Stoelting Distributor for further assistance.

Error Code 3 - Run Time

The Run Time Error (E3) occurs when the compressor runs continuously for an extended period. This error is often caused by very low mix levels in the hopper. Make sure the autofill system is filling the hopper properly.

In air cooled machines, the Run Time Error may indicate that airflow within the machine has reduced or stopped. Check the sides of the machine for anything that would restrict airflow.

If the error persists after attempting to clear it, contact your Authorized Stoelting Distributor for further assistance.

NOTE

When the machine encounters a Run Time Error, the machine will continue to run using preset timers. This mode will allow the operator to continue serving product until the machine can be serviced.

Error Code 4 - Clean

If the machine is left in the Clean Mode for more than 20 minutes, the control panel will display a Clean Error (E4). This condition does not reflect a problem with the machine itself. The Clean Error has been programmed into the controller as a safeguard to protect the machine from potential damage caused by the machine being accidentally left in "Clean Mode". To clear the Clean Error, press the On/Off button for the cylinder to turn it off then back on.

Error Code 5 - Freezing Cylinder Sensor

The Freezing Cylinder Sensor Error (E5) indicates a failure of the barrel sensor or if the sensor is out of range. If the control panel displays an E5, press the On/Off button for the cylinder to turn it off then back on. If the error persists, contact your Authorized Stoelting Distributor for further assistance.

NOTE

When the machine encounters a Freezing Cylinder Sensor Error, the machine will continue to run using preset timers. This mode will allow the operator to continue serving product until the machine can be serviced.

Error Code 6 - Hopper Sensor (single hopper machines)

The Hopper Sensor Error (E6) will not occur on the machine.

Error Code 7 - Drive Motor

If the control panel displays a Drive Motor Error (E7), the control does not sense current coming from the drive motor. Press the On/Off button for the cylinder to turn if off then back on. If the error persists, contact your Authorized Stoelting Distributor for further assistance.

Error Code 8 - Cab Sensor

A Cab Sensor Error (E8) will not occur on the machine.

Error Code 9 - High Pressure Cutout

A High Pressure Cutout Error (E9) will not occur on the machine.

Error Code 10 - Auxiliary Sensor

An Auxiliary Temperature Sensor Error (E10) occurs if the temperature sensor on the control board fails. Press the On/Off button for the cylinder to turn if off then back on. If the error persists, contact your Authorized Stoelting Distributor for further assistance.

Error Code 11 - Prime Error

The Prime Error (E11) will not occur on the machine.

Error Code 12 - Left Hopper Sensor

The Left Hopper Sensor Error (E12) indicates a failure of the hopper sensor or if the sensor is out of range. If the control panel displays an E12, press the On/Off button for the cylinder to turn if off then back on. If the error persists, contact your Authorized Stoelting Distributor for further assistance.

Error Code 13 - Right Hopper Sensor

The Right Hopper Sensor Error (E13) indicates a failure of the hopper sensor or if the sensor is out of range. If the control panel displays an E12, press the On/Off button for the cylinder to turn if off then back on. If the error persists, contact your Authorized Stoelting Distributor for further assistance.

Error Code 21 - Spigot Open Time

The Spigot Open Time Error (E21) indicates a failure of the spigot switch. If the control senses the spigot is open continuously for 10 minutes, the machine will go into Sleep 3 mode. If the control panel displays an E21, press the On/Off button for the cylinder to turn if off then back on. If the error persists, contact your Authorized Stoelting Distributor for further assistance.

4.3 TROUBLESHOOTING - MACHINE

PROBLEM	POSSIBLE CAUSE	REMEDY
Machine does not run.	<ol style="list-style-type: none"> 1 Power to machine is off. 2 Freeze-up (auger will not turn). 3 Front door not in place. 	<ol style="list-style-type: none"> 1 Supply power to machine. 2 Turn off barrel for 15 minutes by pressing the On/Off Left or On/Off Right button, then restart. 3 Assemble front door in place.
Machine will not shut off.	<ol style="list-style-type: none"> 1 Consistency temperature setting is too firm. 2 Refrigeration problem. 	<ol style="list-style-type: none"> 1 Turn Consistency Adjustment screw counter-clockwise. 2 Check system. (Call distributor for service)
Product is too firm.	<ol style="list-style-type: none"> 1 Consistency temperature setting is too firm. 	<ol style="list-style-type: none"> 1 Turn Consistency Adjustment screw counter-clockwise.
Product is too thin.	<ol style="list-style-type: none"> 1 No vent space for free flow of cooling air. 2 Condenser is dirty. 3 Consistency setting too soft. 4 Auger is assembled incorrectly. 5 Auto Fill Pump not operating. 6 Refrigeration problem. 	<ol style="list-style-type: none"> 1 A minimum of 6" of air space on both sides. (See Section 2) 2 Clean. (See Section 3) 3 Turn Consistency Adjustment screw clockwise. 4 Remove mix, clean, reassemble, sanitize and freeze down. 5 See Auto Fill Troubleshooting section. 6 Check system. (Call distributor for service)
Product does not dispense.	<ol style="list-style-type: none"> 1 No mix in hopper. 2 Drive motor overload tripped. 3 Drive belt failure. 4 Freeze-up (Auger will not turn). 	<ol style="list-style-type: none"> 1 See Auto Fill Troubleshooting section. 2 Wait for automatic reset. (If condition continues, call distributor for service.) 3 Replace drive belt. 4 Turn off cylinder, wait for 15 minutes, then restart.
Drive belt slipping or squealing.	<ol style="list-style-type: none"> 1 Worn drive belt. 2 Freeze-up (Auger will not turn). 3 Not tensioned properly. 	<ol style="list-style-type: none"> 1 Replace drive belt. 2 Turn off cylinder, wait for 15 minutes, then restart. 3 Adjust belt tension
Rear auger seal leaks.	<ol style="list-style-type: none"> 1 Outside surface of rear auger seal is lubricated. 2 Rear seal missing or damaged. 3 Seal o-ring missing, damaged or installed incorrectly. 4 Worn or scratched auger shaft. 	<ol style="list-style-type: none"> 1 Clean lubricant from outside of rear seal and thoroughly clean rear of freezing cylinder. Lubricate inside of seal and reinstall. 2 Check or replace. 3 Check or replace. 4 Replace auger shaft.
Front door leaks.	<ol style="list-style-type: none"> 1 Front door knobs are loose. 2 Spigot parts are not lubricated. 3 Chipped or worn spigot o-rings. 4 O-rings or spigot installed wrong. 5 Inner spigot hole in front door nicked or scratched. 	<ol style="list-style-type: none"> 1 Tighten knobs. 2 See Section 3. 3 Replace o-rings. 4 Remove spigot and check o-ring. 5 Replace front door.

4.4 TROUBLESHOOTING - AUTOFILL PUMP

PROBLEM	POSSIBLE CAUSE	REMEDY
Pump does not operate.	<ol style="list-style-type: none"> 1 Low water pressure. 2 Restriction or plugged auto fill system. 3 Empty BIB 	<ol style="list-style-type: none"> 1 Verify that there is adequate water pressure at the inlet fitting (30-50 psi). 2 Flush and sanitize the pump and tubing. 3 Replace BIB
Syrup concentration incorrect	<ol style="list-style-type: none"> 1 BIB connector is not connected to the BIB properly. 2 Leak at the connections or in the tubing. 3 Air in the BIB syrup container. 4 Pump is clogged with debris or particulates. 	<ol style="list-style-type: none"> 1 Check connection and reconnect if necessary. 2 Look for leaks at the connections and bubbles in the tubing. Tighten clamps and replace tubing if necessary. 3 Remove the air from the BIB syrup container. 4 Remove syrup valves and inspect for debris or improper closing that would interfere with operation.

SECTION 5 REPLACEMENT PARTS

5.1 DECALS AND LUBRICATION

Part	Description	Quantity
208135	Brush - 4" X 8" X 16" (Barrel)	1
208380	Brush - 1/4" X 3" X 14"	1
208401	Brush - 1" X 3" X 10"	1
236054	Cleaning Card - Auto Fill Pump Kit	1
236065	Card - Cleaning Instruction - E122 & F122	1
236066	Card - Cleaning Instruction - Brix Pump	1
324105	Decal - Caution Electrical Shock	1
324106	Decal - Caution Electrical Wiring Materials	1
324107	Decal - Caution Hazardous Moving Parts	1
324141	Decal - Caution Rotating Blades	1
324208	Decal - Attention Refrigerant Leak Check	1
324393	Decal - Stoelting Swirl Logo	1
324509	Decal - Cleaning Instruction	1
324548	Decal - Adequate Ventilation 6"	1
324594	Decal - Attention Heat Sensitive	2
324686	Decal - Danger Automatic Start	2
324804	Decal - Domed Stoelting Swirl (Header Panel)	1
324888	Decal - Fan Motor Reset	1
324901	Decal - Transformer Switch	1
324909	Decal - USB Port	1
324922	Decal - Assembly Check	1
324938	Decal - 4" Ventilation	1
508048	Lubricant - Spline (2 oz Squeeze Tube)	1
508135	Petrol Gel - 4 oz Tube	1

5.2 AUGER SHAFT AND FACEPLATE PARTS

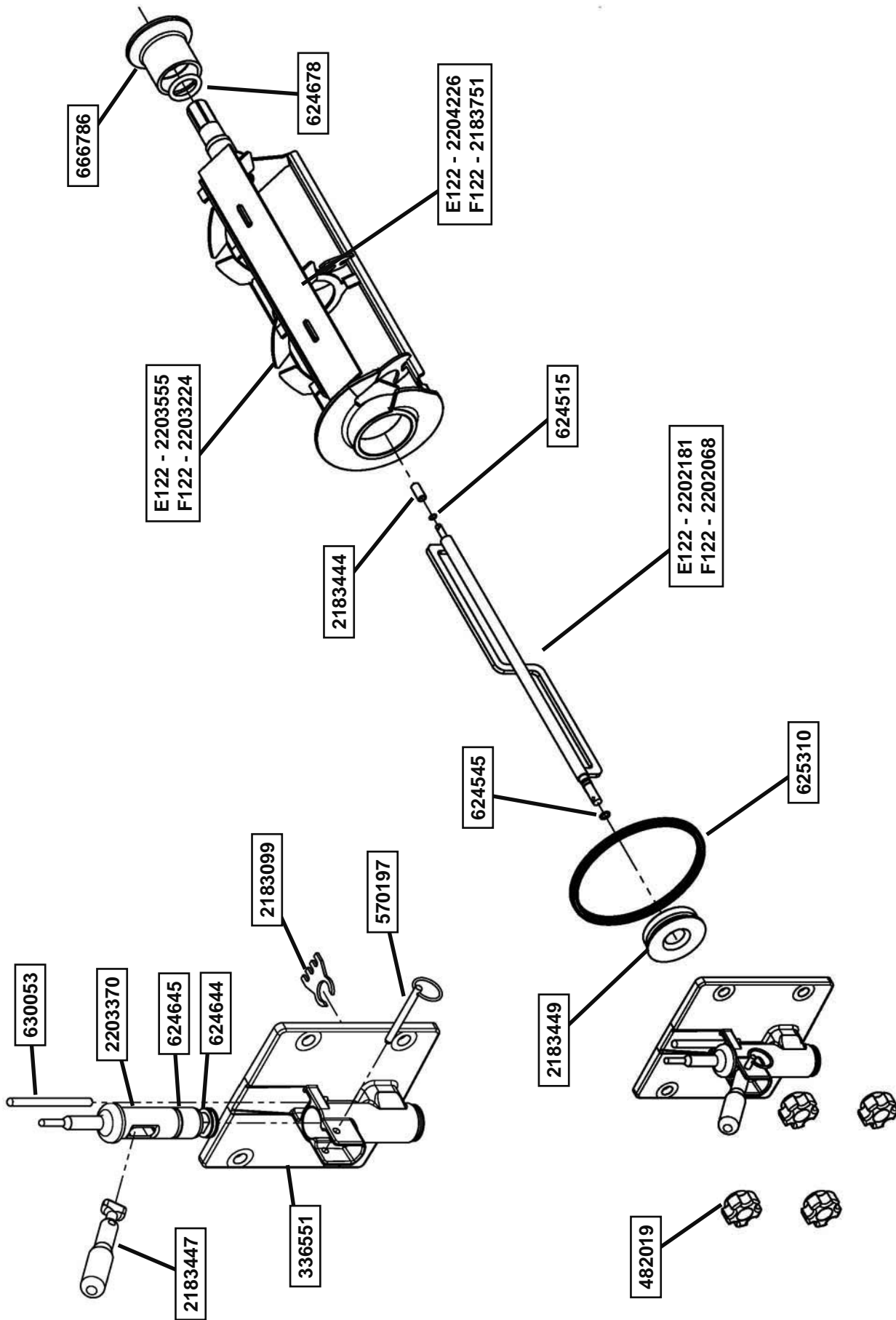

5.2 AUGER SHAFT AND FACEPLATE PARTS - CONTINUED

Part	Description	Quantity
336551	Door - Front	2
482019	Knob - Front Door (Black)	8
570197	Pin - Cotterless Clevis (Front Door)	2
624515-5	O-Ring - Stator Bar Rear (5 Pack)	2
624545-5	O-Ring - Stator Bar Front (5 Pack)	2
624644-5	O-Ring - Spigot Body (Bottom) (5 Pack)	2
624645-5	O-Ring - Spigot Body (Top) (5 Pack)	2
624678-5	O-Ring - Rear Seal - Black (5 Pack)	2
625310	Quad-Ring - Front Door - Black	2
630053	Rod - Torque Actuator	2
666786	Seal - Rear Auger - Black	2
2183099	Breaker Bar - Spigot Body	2
2183444	Bushing - Stator Support (Rear)	2
2183447	Handle Only - Spigot	2
2183449	Bushing - Front Auger Support	2
2183751	Blade - Scraper	F122 - 2
2202068	Stator Bar	F122 - 2
2202181	Stator Bar	E122 - 2
2203224	Auger Shaft	F122 - 2
2203370	Spigot Body	2
2203555	Auger Shaft	E122 - 2
2204226	Blade - Scraper	E122 - 2

5.3 HOPPER PARTS

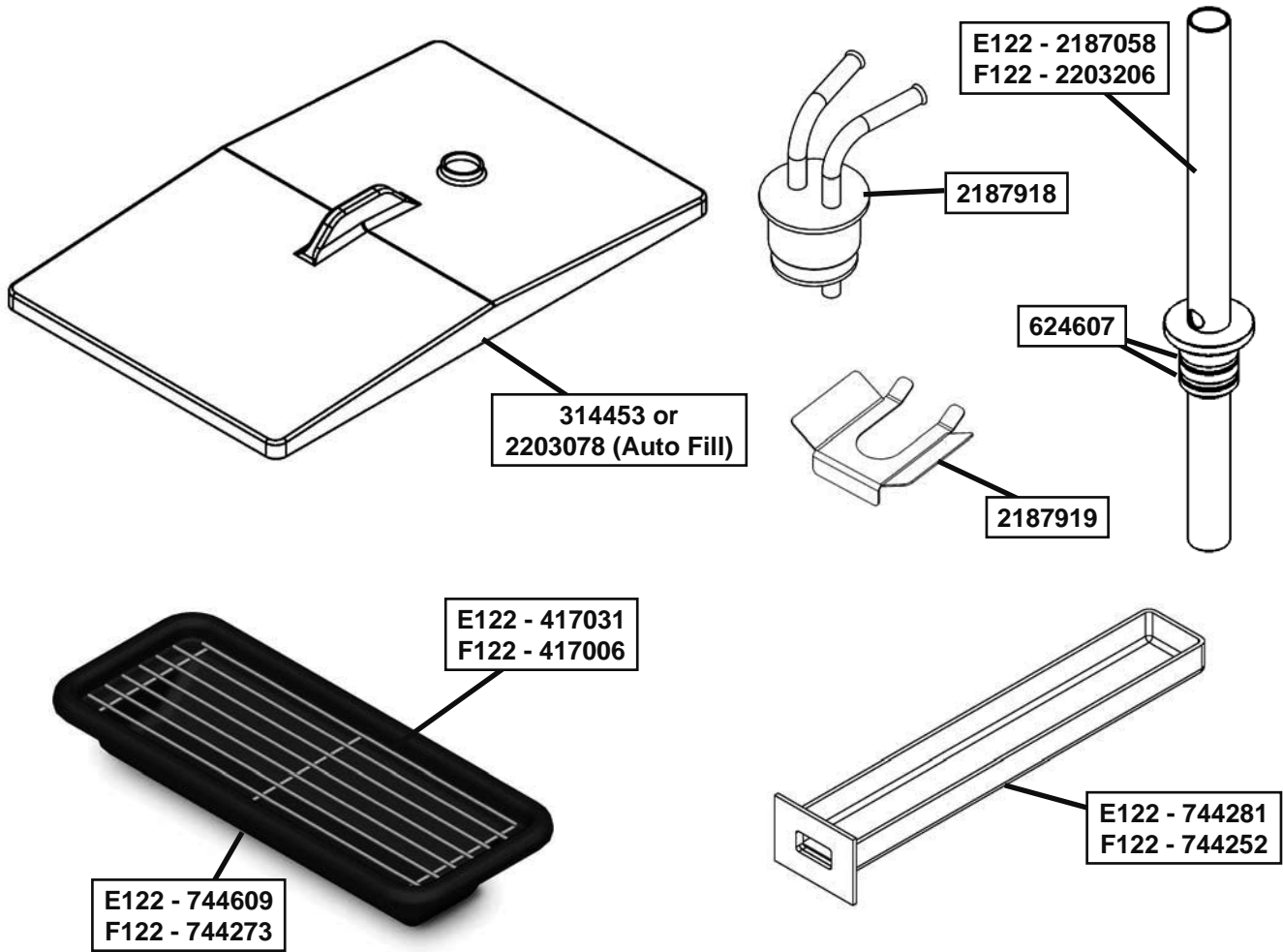

Part	Description	Quantity
314453	Cover - Hopper	2
417006	Grid - Drip Tray (Vinyl Coated Metal)	F122 - 1
417031	Grid - Drip Tray	E122 - 1
624607-5	O-Ring - Mix Inlet	4
744252	Tray - Drain	F122 - 1
744281	Tray - Drain	E122 - 1
744273	Tray - Drip	F122 - 1
744609	Tray - Drip	E122 - 1
2187058	Mix Inlet Regulator	E122 - 2
2187918	Mix Inlet Assembly (Auto Fill)	2
2187919	Clip - Retaining (Mix Inlet)	2
2203078	Cover - Hopper (Autofill)	2
2203206	Mix Inlet Regulator	F122 - 2

5.4 AUTO FILL PARTS

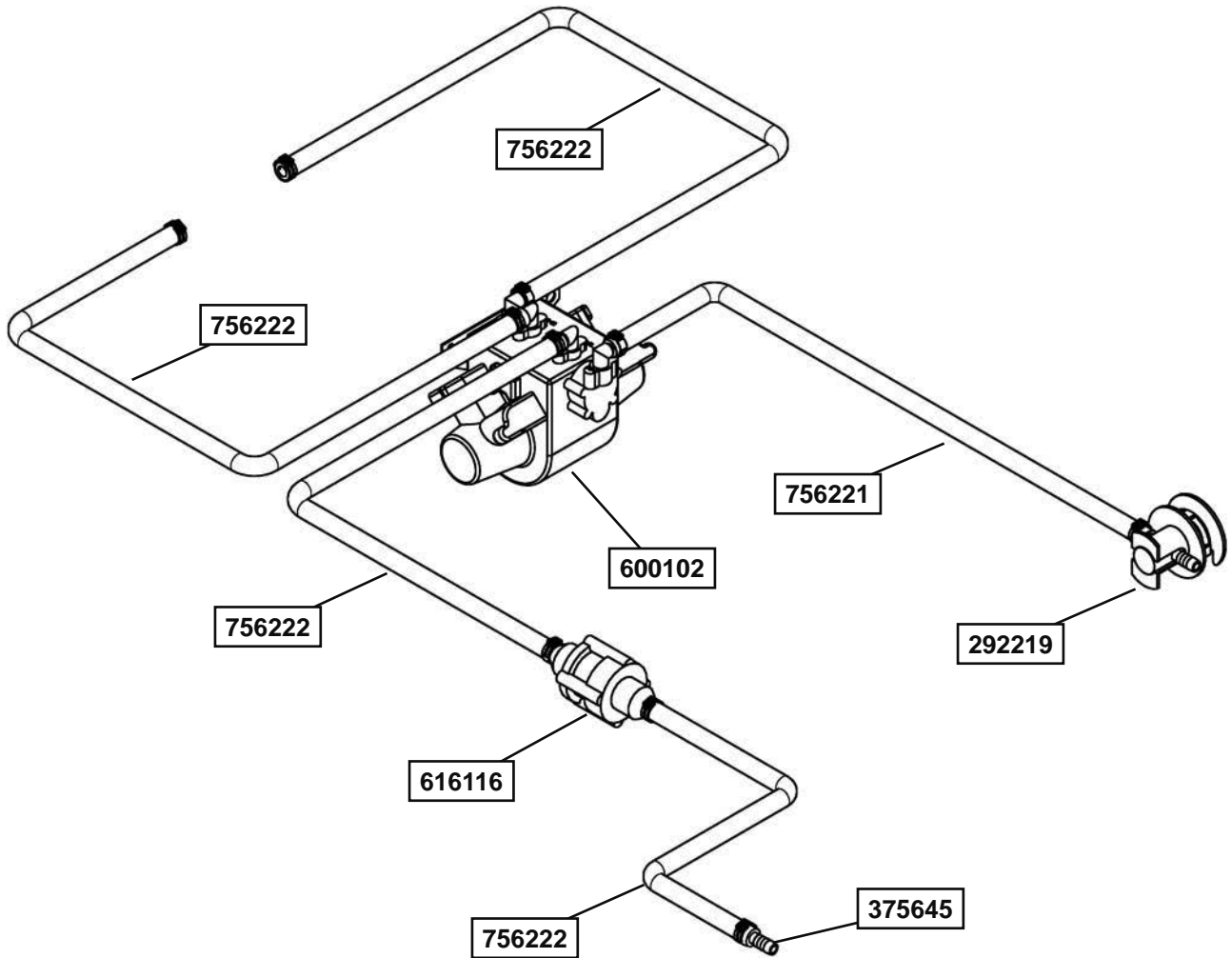

Part	Description	Quantity
264100	Clamp - Oetiker Stepless (#17)	4
264101	Clamp - Oetiker Stepless (#15.7)	46
292219	Connector - Bag In Box	2
375645	Fitting - 3/8" x 3/8"	2
538463	Nut	4
600102	Pump - Brix (3:1 Ratio)	2
616116	Water Regulator	2
647660	Screw - 10-32 x 3/8"	4
739126	Tie Wrap - 15"	19
739127	Tie Wrap - 7"	4
756221	Tubing - 3/8" Clear	6'
756222	Tubing - 3/8" Braided	80'

SECTION 6
SPECIAL APPLICATIONS



502 Hwy 67 Kiel, Wisconsin 53042
T: 920-894-2293 | 800-558-5807
F: 920-894-7029 www.stoelting.com

Re: Application of Stoelting F122 and Arctic Quake Non-Dairy concentrate product

Welcome to Arctic Quake

Stoelting’s policy regarding cleaning of the equipment is that for the frequency of cleaning the freezer and freezer parts the end-user should refer to their state and local health regulations.

Stoelting Foodservice equipment does go through NSF testing and subsequent NSF approval. During the NSF testing and approval, Stoelting’s machines are tested and approved for “cleanability” not for frequency of cleaning.

In the application of this type of freezer, customers using the Arctic Quake products have a cleaning cycle of 5-14 days. In staying within this type of cleaning schedule, the machine will function properly.

ISO 9001:2000 Registered

**SECTION 7
WARRANTY**



**WARRANTY
FROZEN UNCARBONATED BEVERAGE EQUIPMENT**

1. **Scope:**
PW Stoelting, L.L.C. (“Stoelting”) warrants to the first user (the “Buyer”) that the evaporator assembly, compressors, drive motors, and speed reducers of Stoelting frozen uncarbonated beverage equipment will be free from defects in materials and workmanship under normal use and proper maintenance appearing within five (5) years, and that all other components of such equipment manufactured by Stoelting will be free from defects in material and workmanship under normal use and proper maintenance appearing within twelve (12) months after the date that such equipment is originally installed.

2. **Disclaimer of Other Warranties:**

THIS WARRANTY IS EXCLUSIVE; AND STOELTING, HEREBY DISCLAIMS ANY IMPLIED WARRANTY OF MERCHANTABILITY OR FITNESS FOR PARTICULAR PURPOSE.

3. **Remedies:**
Stoelting’s sole obligations, and Buyer’s sole remedies, for any breach of this warranty shall be the repair or (at Stoelting’s option) replacement of the affected component at Stoelting’s plant in Kiel, Wisconsin, or (again, at Stoelting’s option) refund of the purchase price of the affected equipment, and, during the first twelve (12) months of the warranty period, deinstallation/reinstallation of the affected component from/into the equipment. Those obligations/remedies are subject to the conditions that Buyer (a) signs and returns to Stoelting, upon installation, the Start-Up and Training Checklist for the affected equipment, (b) gives Stoelting prompt written notice of any claimed breach of warranty within the applicable warranty period, and (c) delivers the affected equipment to Stoelting or its designated service location, in its original packaging/crating, also within that period. Buyer shall bear the cost and risk of shipping to and from Stoelting’s plant or designated service location.

4. **Exclusions and Limitations:**
This warranty does not extend to parts, sometimes called “wear parts”, which are generally expected to deteriorate and to require replacement as equipment is used, including as examples but not intended to be limited to o-rings, hoses, seals, and drive belts. All such parts are sold

AS IS.

Further, Stoelting shall not be responsible to provide any remedy under this warranty with respect to any component that fails by reason of negligence, abnormal use, misuse or abuse, use with parts or equipment not manufactured or supplied by Stoelting, or damage in transit.

THE REMEDIES SET FORTH IN THIS WARRANTY SHALL BE THE SOLE LIABILITY STOELTING AND THE EXCLUSIVE REMEDY OF BUYER WITH RESPECT TO EQUIPMENT SUPPLIED BY STOELTING; AND IN NO EVENT SHALL STOELTING BE LIABLE FOR ANY INCIDENTAL OR CONSEQUENTIAL DAMAGES, WHETHER FOR BREACH OF WARRANTY OR OTHER CONTRACT BREACH, NEGLIGENCE OR OTHER TORT, OR ON ANY STRICT LIABILITY THEORY.

