



Model E157A / E257A
OPERATORS MANUAL

Manual No. 513651

Apr. 2010

This manual provides basic information about the machine. Instructions and suggestions are given covering its operation and care.

The illustrations and specifications are not binding in detail. We reserve the right to make changes to the machine without notice, and without incurring any obligation to modify or provide new parts for machines built prior to date of change.

DO NOT ATTEMPT to operate the machine until instructions and safety precautions in this manual are read completely and are thoroughly understood. If problems develop or questions arise in connection with installation, operation, or servicing of the machine, contact Stoelting.



stoeltingfoodservice.com

Stoelting Foodservice Equipment
502 Highway 67
Kiel, WI 53042-1600
U.S.A.

Main Tel: 800.558.5807
Fax: 920.894.7029

Customer Service: 888.429.5920
Fax: 800.545.0662
Email: foodservice@stoelting.com

© 2014 PW Stoelting, LLC

A Few Words About Safety

Safety Information

Read and understand the entire manual before operating or maintaining Stoelting equipment.

This manual provides the operator with information for the safe operation and maintenance of Stoelting equipment. As with any machine, there are hazards associated with their operation. For this reason safety is emphasized throughout the manual. To highlight specific safety information, the following safety definitions are provided to assist the reader.

The purpose of safety symbols is to attract your attention to possible dangers. The safety symbols, and their explanations, deserve your careful attention and understanding. The safety warnings do not by themselves eliminate any danger. The instructions or warnings they give are not substitutes for proper accident prevention measures.

If you need to replace a part, use genuine Stoelting parts with the correct part number or an equivalent part. We strongly recommend that you do not use replacement parts of inferior quality.



Safety Alert Symbol:

This symbol Indicates danger, warning or caution. Attention is required in order to avoid serious personal injury. The message that follows the symbol contains important information about safety.

Signal Word:

Signal words are distinctive words used throughout this manual that alert the reader to the existence and relative degree of a hazard.



The signal word "WARNING" indicates a potentially hazardous situation, which, if not avoided, may result in death or serious injury and equipment/property damage.



The signal word "CAUTION" indicates a potentially hazardous situation, which, if not avoided, may result in minor or moderate injury and equipment/property damage.

CAUTION

The signal word "CAUTION" not preceded by the safety alert symbol indicates a potentially hazardous situation, which, if not avoided, may result in equipment/property damage.

NOTE (or NOTICE)

The signal word "NOTICE" indicates information or procedures that relate directly or indirectly to the safety of personnel or equipment/property.

TABLE OF CONTENTS

SECTION 1 - INTRODUCTION	1
1.1 Description	1
1.2 Specifications	1
SECTION 2 - INSTALLATION INSTRUCTIONS	3
2.1 Safety Precautions	3
2.2 Shipment and Transit	3
2.3 Freezer Installation	3
2.4 Adjusting Cup Dispensers	7
SECTION 3 - INITIAL SET-UP AND OPERATION	9
3.1 Operator's Safety Precautions	9
3.2 Operating Controls and Indicators	9
3.3 Draining The Freezer For Disassembling and Cleaning	10
3.4 Disassembly and Cleaning of Freezer Parts	10
3.5 Sanitizing The Freezers and Freezer Parts	15
3.6 Assembly of Freezer	15
3.7 Mix Information	17
3.8 Freeze Down and Operation	17
3.9 Dispensing Product	17
3.10 Routine Cleaning	17
3.11 Preventative Maintenance	17
3.12 Extended Storage	18
SECTION 4 - DECALS AND TAGS	21
4.1 How to Order Decals and Tags	21

SECTION 1 INTRODUCTION

1.1 DESCRIPTION

Models E157A and E257A freezers are gravity fed. The freezers are equipped with fully automatic controls to provide a uniform product. The freezers are designed to operate with most neutral bases and concentrated flavors.

This manual is designed to assist qualified service personnel and operators in the installation, operation and maintenance of the Models E157A and E257A freezers.

1.2 SPECIFICATIONS

	Model E157A (LE157A)		Model E257A (LE257A)	
	Machine	with crate	Machine	with crate
Dimensions				
width	15" (38,1 cm)	28" (71,1 cm)	15" (38,1 cm)	17" (43,2 cm)
height	32" (81,3 cm)	40-1/4" (102,2 cm)	58" (147,3 cm)	66" (167,6 cm)
depth	29-1/2" (74,9 cm)	35-1/2" (90,2 cm)	15" (38,1 cm)	21" (53,3 cm)
Weight	142 lbs (64,4 kg)	200 lbs (90,7 kg)	140 lbs (63,5 kg)	165 lbs (74,8 kg)
Electrical	1 Phase, 115 VAC, 60Hz			
running amps	approximately 9A			
connection type	NEMA5-15P included			
International Option	1 Phase, 220-240 VAC, 50Hz			
Compressor	2,250 Btu/hr (R-404A)			
Drive Motor	1/12 hp			
Cooling	Air cooled units require 6" (15,2 cm) air space on sides and back			
Hopper Volume	10 gallon (37,85 liters)			

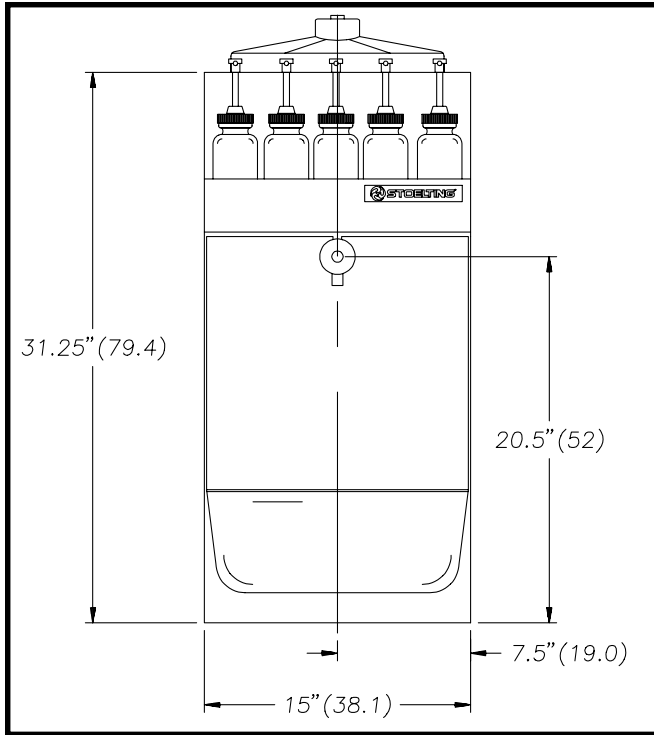

Figure 1
Model E157A - Front

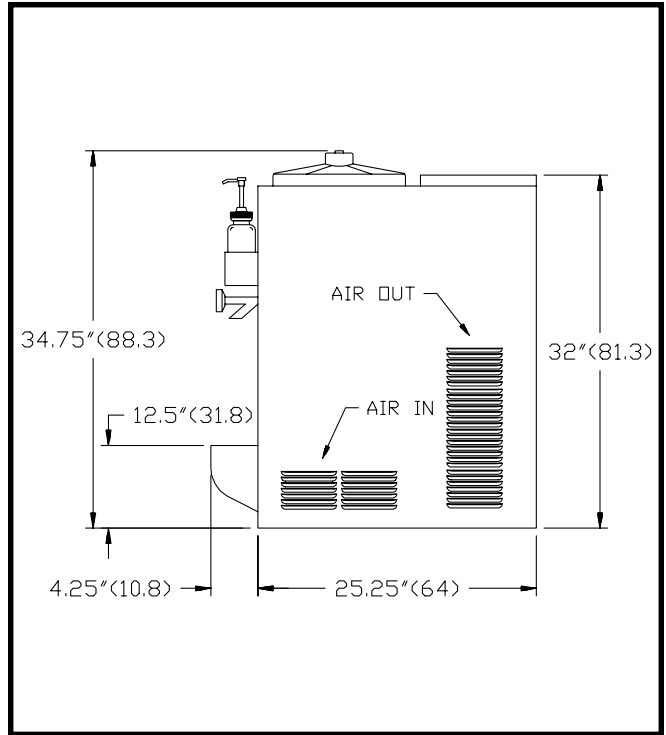

Figure 2
Model E157A - Side

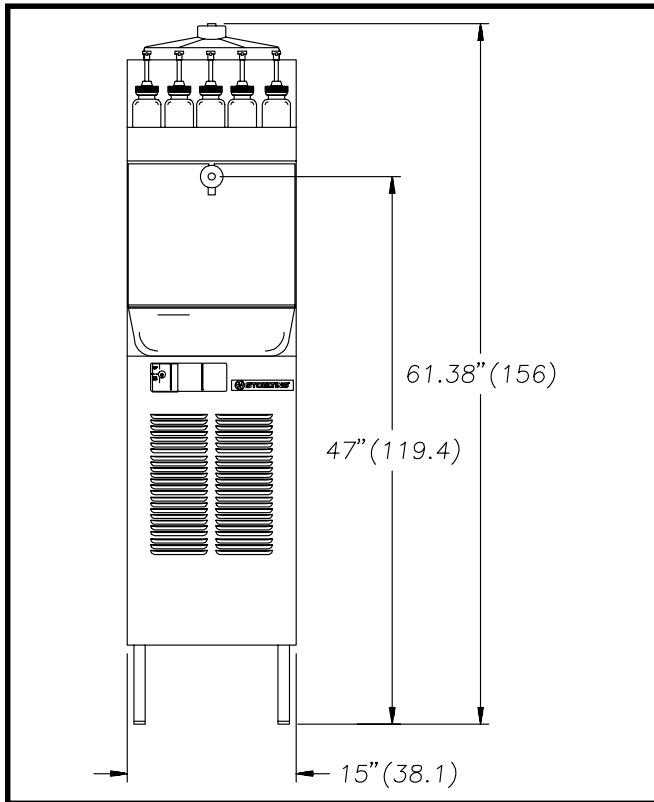

Figure 3
Model E257A - Front

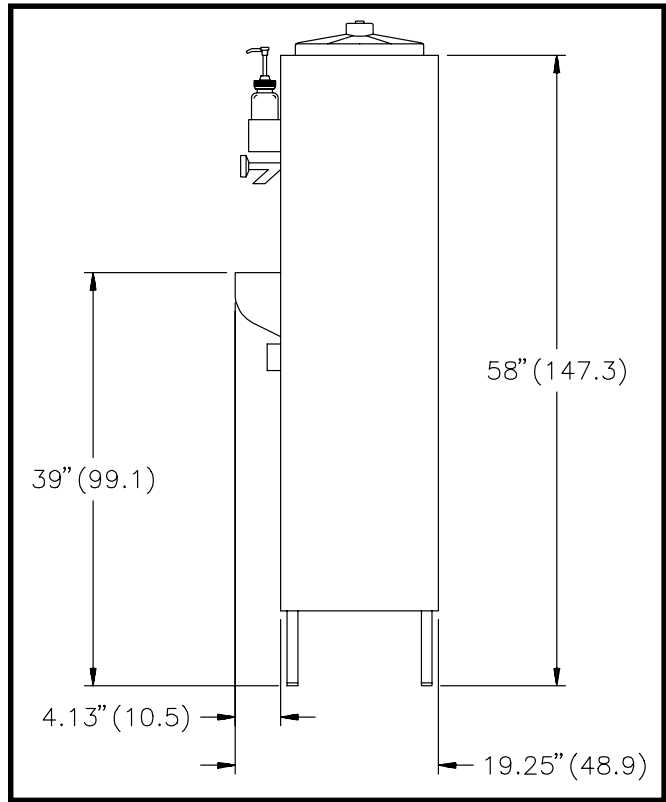

Figure 4
Model E257A - Side

NOTE: Figures in parenthesis are in centimeters.

SECTION 2 INSTALLATION INSTRUCTIONS

2.1 SAFETY PRECAUTIONS

Do not attempt to operate the freezer until the safety precautions and operating instructions in this manual are read and completely understood.

Take notice of all warning labels on the freezer (Figures 6 & 7). The labels have been put there to help maintain a safe working environment. The labels have been designed to withstand washing and cleaning. All labels must remain legible for the life of the freezer. Labels should be checked periodically to be sure they can be recognized as warning labels.

If danger, warning, or caution labels are needed, indicate the part number, type of label, location of label, and quantity required along with your address and advise your distributor.

2.2 SHIPMENT AND TRANSIT

The freezer has been assembled, operated and inspected at the factory. Upon arrival at the final destination, the complete freezer must be checked for any damage which may have occurred during transit.

With the method of packaging used, the freezer should arrive in excellent condition. **THE CARRIER IS RESPONSIBLE FOR ALL DAMAGE IN TRANSIT, WHETHER VISIBLE OR CONCEALED.**

Do not pay the freight bill until the freezer has been checked for damage. Have the carrier note any visible damage on the freight bill. If concealed damage and/or shortage is found later, advise the carrier within 10 days and request inspection. The customer must place claim for damages and/or shortages in shipment with the carrier.

2.3 FREEZER INSTALLATION

Installation of the freezer involves moving the freezer close to its permanent location, removing all crating, setting in place, assembling parts, and cleaning.

- A. Uncrate the freezer.
- B. The floor model freezers must be placed in a solid level position. To level the freezer, turn the bottom part of each leg in or out. Place a level on top of the hopper, with the cover removed, to check whether or not the freezer is level (Fig. 5).

NOTE

Accurate leveling is necessary for correct drainage of freezer barrel and to insure proper operation.

- C. The counter model freezer must be placed on a solid level surface. Place the rubber pad furnished under the freezer to create a seal to that surface. The counter model freezer is air-cooled and discharges at the top. **AL LOUVERED PANELS MUST** have 3" of clearance on sides of unit, 10" of clearance at the top, and 1" clearance at rear of unit for proper cooling.

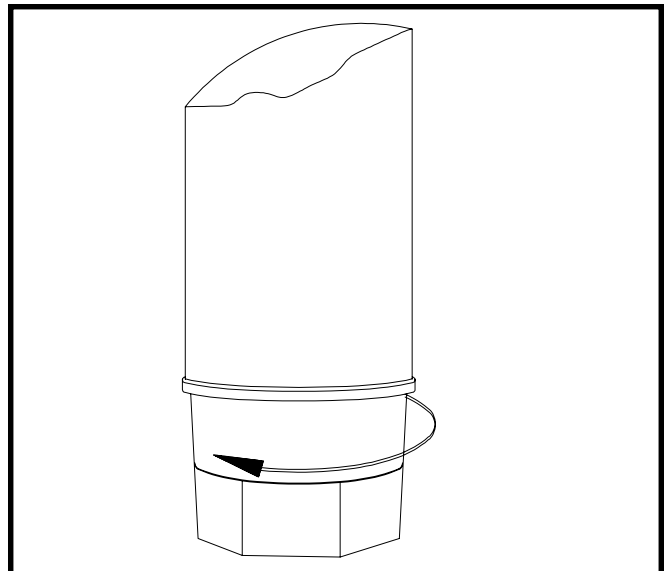

**Figure 5
Adjustable Leg**

IMPORTANT NOTICE TO OPERATOR

BEFORE INSTALLING EQUIPMENT, READ THE OWNER'S MANUAL CAREFULLY. TAKE NOTE OF ALL INSTRUCTIONS AND CAUTION DECALS ON THIS EQUIPMENT.

GO OVER THE MANUAL THOROUGHLY AND POINT OUT ALL DECALS TO YOUR EMPLOYEES, SO THEY UNDERSTAND HOW TO SAFELY OPERATE THIS EQUIPMENT.

DO NOT REMOVE, DEFACE, OR PAINT OVER ANY DECALS. THEY ARE THERE FOR YOUR SAFETY.

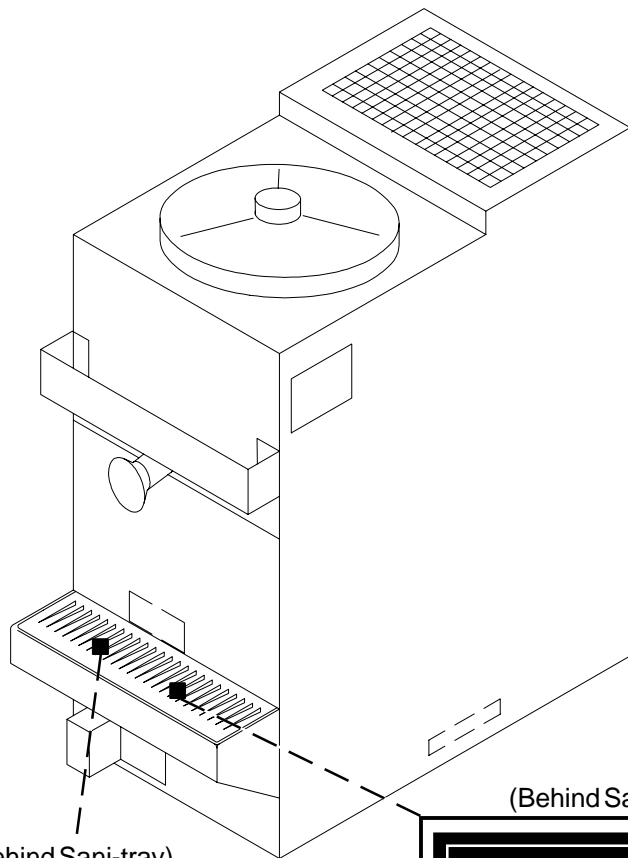

CAUTION

THIS DEVICE MUST BE PLUGGED INTO A GROUNDED RECEPTACLE TO PREVENT SHOCK HAZARD.

324113

(Behind Sani-tray)

CAUTION

HAZARDOUS MOVING PARTS
DO NOT OPERATE UNIT WITH OUTER COVERING REMOVED.

S24107

(Behind Sani-tray)

DANGER

ELECTRONIC SHOCK HAZARD
DISCONNECT FROM THE SOURCE OF ELECTRICAL SUPPLY IN BUILDING BEFORE SERVICING UNIT

321105

CAUTION

THIS DEVICE MUST BE PLUGGED INTO A PROPERLY GROUNDED RECEPTACLE TO PREVENT ELECTRICAL SHOCK HAZARD.

TAMPERING WITH THE PLUG OR USING VOLTAGES OTHER THAN THE SPECIFICATIONS ON I.D. PLATE WILL VOID YOUR WARRANTY.

REFER TO OWNER'S MANUAL FOR INSTALLATION INSTRUCTIONS.

723529

Figure 6
Warning Label Locations - E157A

IMPORTANT NOTICE TO OPERATOR

BEFORE INSTALLING EQUIPMENT, READ THE OWNER'S MANUAL CAREFULLY. TAKE NOTE OF ALL INSTRUCTIONS AND CAUTION DECALS ON THIS EQUIPMENT.

GO OVER THE MANUAL THOROUGHLY AND POINT OUT ALL DECALS TO YOUR EMPLOYEES, SO THEY UNDERSTAND HOW TO SAFELY OPERATE THIS EQUIPMENT.

DO NOT REMOVE, DEFACE, OR PAINT OVER ANY DECALS. THEY ARE THERE FOR YOUR SAFETY.

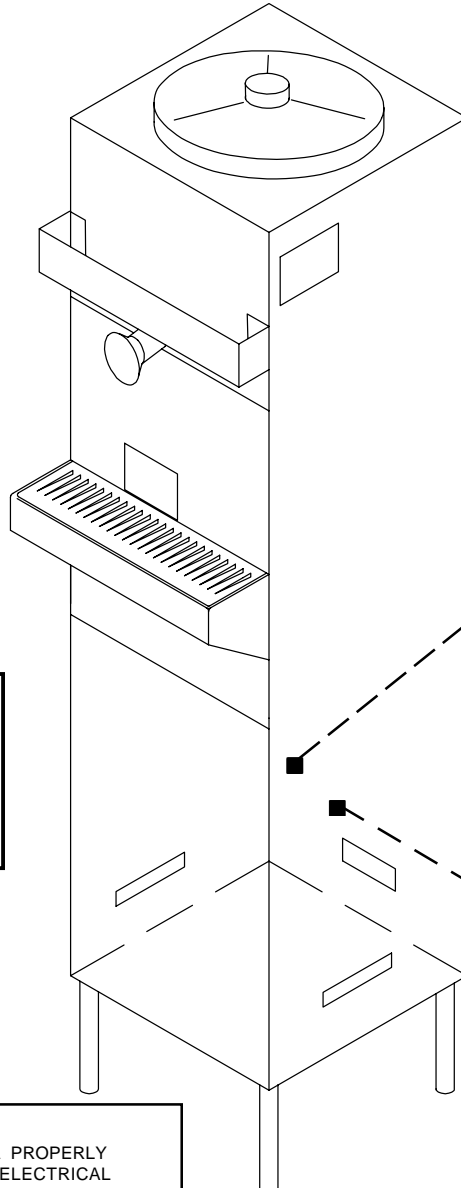

CAUTION

THIS DEVICE MUST BE PLUGGED INTO A GROUNDED RECEPTACLE TO PREVENT SHOCK HAZARD.

324113

(Affixed to condenser shroud)

CAUTION

HAZARDOUS MOVING PARTS
DO NOT OPERATE UNIT WITH OUTER COVERING REMOVED

324107

(Affixed to condenser shroud)

DANGER

ELECTRONIC SHOCK HAZARD
DISCONNECT FROM THE SOURCE OF ELECTRICAL SUPPLY IN BUILDING BEFORE SERVICING UNIT

321105

CAUTION

THIS DEVICE MUST BE PLUGGED INTO A PROPERLY GROUNDED RECEPTACLE TO PREVENT ELECTRICAL SHOCK HAZARD.

TAMPERING WITH THE PLUG OR USING VOLTAGES OTHER THAN THE SPECIFICATIONS ON I.D. PLATE WILL VOID YOUR WARRANTY.

REFER TO OWNER'S MANUAL FOR INSTALLATION INSTRUCTIONS.

723529

Figure 7

Warning Label Locations - E257A

D. The floor model freezers are equipped with air-cooled condensers and require correct ventilation. The front of the freezer is the air intake and must be unobstructed. Air discharges out of the rear of the unit. Do not obstruct the discharge. Allow a 6" (15.2 cm) clearance behind the unit (Fig. 8).

CAUTION
FAILURE TO PROVIDE ADEQUATE VENTILATION WILL VOID WARRANTY!

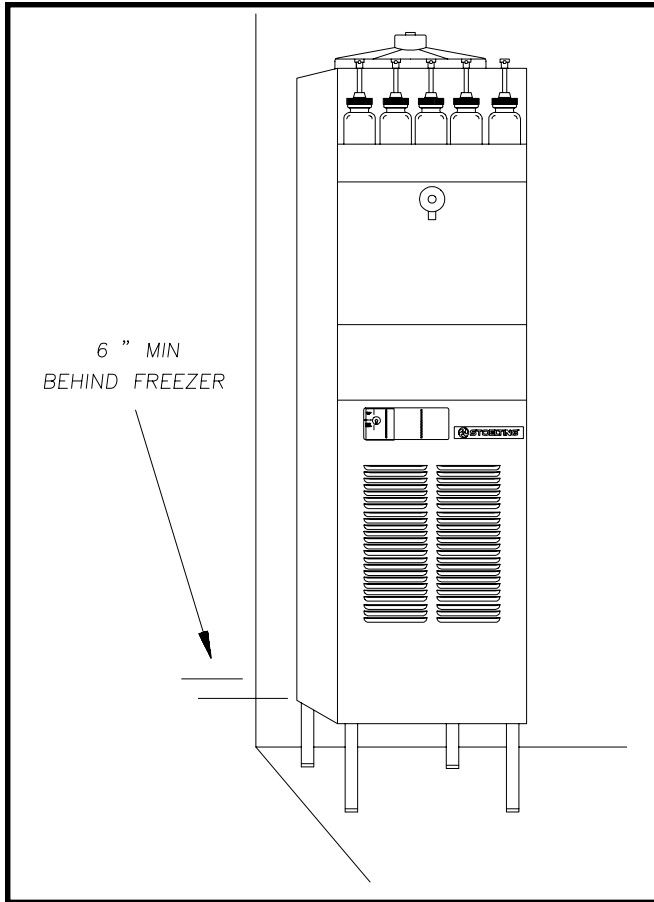

Figure 8
Space and Ventilation Requirements

E. Place the ON-OFF-STIR ONLY toggle switch in the OFF position. This switch is located on the lower left of the freezer, under the drip tray and cover.

F. Connect the power cord. The plug is designed for 115 volt/15 amp duty. The unit must be connected to a properly grounded receptacle. The electrical cord furnished as part of the freezer has a three prong grounding type plug (Fig.9). The use of an extension cord is not recommended. If one must be used, use one with a wire, size 12 gauge or heavier, with a ground. Do not use an adaptor to avoid grounding equipment.

CAUTION
DO NOT ALTER OR DEFORM PLUG IN ANY WAY!

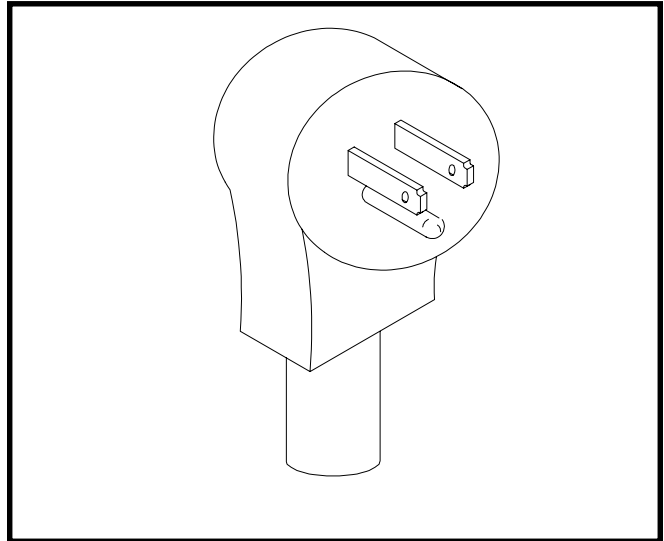

Figure 9
Electrical Plug

G. Install the drip tray support, drip tray, drip tray grid, cover and miscellaneous parts on the freezer. (Fig. 10)

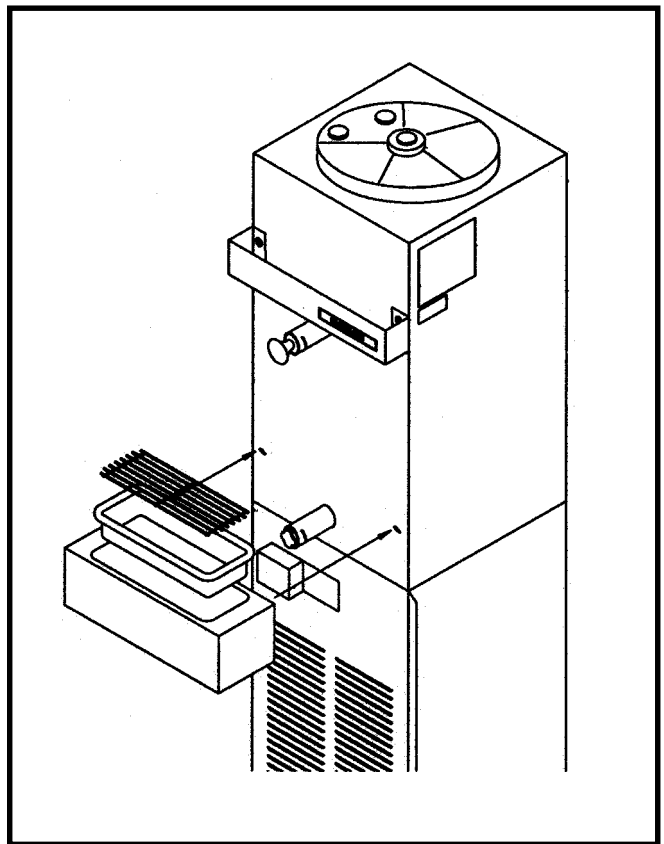

Figure 10
Installing Drip Tray and Cover

2.4 ADJUSTING CUP DISPENSERS

To adjust the cup dispensers, install the size cup desired into the dispenser and turn the wing nuts on the dispenser mounting bracket until enough tension is applied to the rim of the cup to keep it from dropping out (Fig. 11). Do not over-tighten the wing nuts.

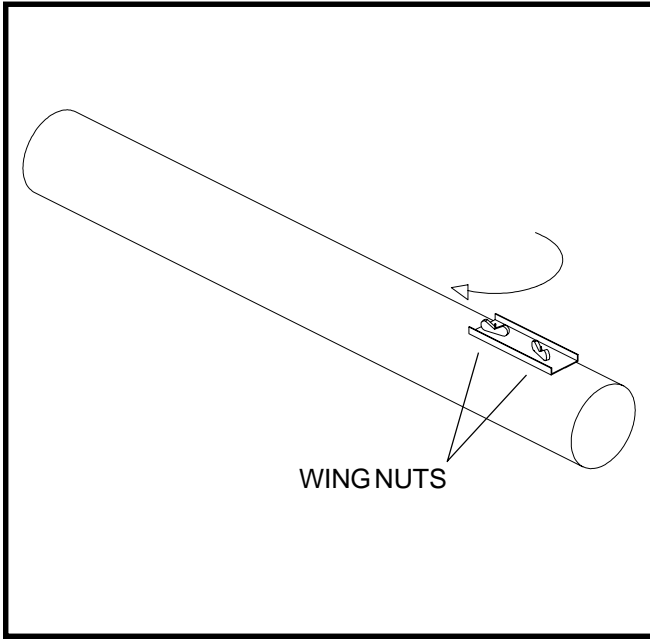

Figure 11
Adjusting Cup Dispensers

SECTION 3 INITIAL SET-UP AND OPERATION

3.1 OPERATOR'S SAFETY PRECAUTIONS

- A. Know the freezer. Read and understand the Operating Instructions.
- B. Notice all warning labels on the freezer.
- C. Wear proper clothing. Avoid loose fitting garments, and remove watches, rings or jewelry which could cause a serious accident.
- D. Maintain a clean work area. Avoid accidents by cleaning up the area and keeping it clean.
- E. Stay alert at all times. Know which switch, push-button or control you are about to use and what effect it is going to have.
- F. Disconnect electrical cord for maintenance. Never attempt to repair or perform maintenance on the freezer until the main electrical power has been disconnected.

- G. Do not operate under unsafe operating conditions. Never operate the freezer if unusual or excessive noise or vibration occurs.

3.2 OPERATING CONTROLS AND INDICATORS

Before operating the freezer, it is required that the operator know the function of each operating control and indicator. Refer to Figure 12 for the locations of the operating controls and indicators.

WARNING

THE STIRRING ONLY-OFF-STIRRING & FREEZING SWITCH MUST BE PLACED IN THE OFF POSITION WHEN DISASSEMBLING FOR CLEANING OR SERVICING. THE FREEZER MUST BE DISCONNECTED FROM ELECTRICAL SUPPLY BEFORE REMOVING ANY ACCESS PANELS. ONLY A QUALIFIED SERVICE TECHNICIAN MAY REMOVE ACCESS PANELS.

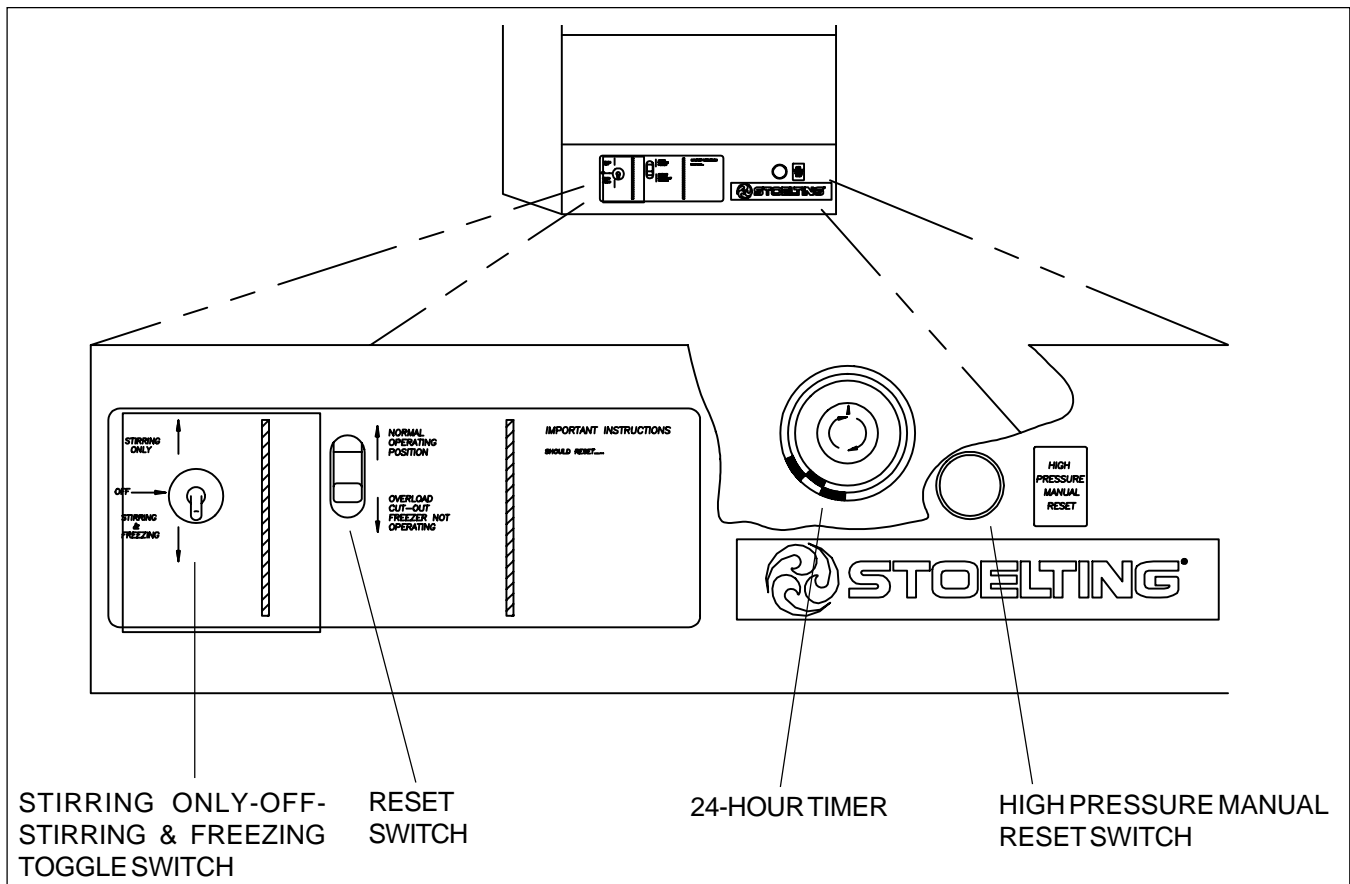

**Figure 12
Operating Controls**

A. STIRRING ONLY-OFF-STIRRING & FREEZING SWITCH

The STIRRING ONLY-OFF-STIRRING & FREEZING switch is a three-position toggle switch used to control the operation of the refrigeration system and agitator. When the switch is placed in the STIRRING ONLY position, the refrigeration system will be off and the agitator will rotate for cleaning, or if stirring is required when the store is closed. When the switch is placed in the OFF position, the refrigeration system and agitator will be off. The switch should be placed in the STIRRING & FREEZING position for normal operation.

B. RESET SWITCH

The reset switch is a two-position breaker switch. This switch is used to protect the freezer from mechanical damage. The switch must be in the NORMAL OPERATING POSITION (up) before the freezer will operate.

Any time a condition occurs which causes the agitator drive motor to draw excessive current, the reset switch will automatically switch to the OVERLOAD CUT-OUT FREEZER NOT OPERATING position. This will shut down the freezing and agitation action of the freezer to protect the agitator drive motor from burning out.

Should the reset switch ever trip out, move the STIRRING ONLY-OFF-STIRRING & FREEZING toggle switch to the STIRRING ONLY position. Then move the reset switch back to NORMAL OPERATING POSITION (up) and allow the freezer to stir, without refrigeration, for five minutes. After five minutes of stirring, return the STIRRING ONLY-OFF-STIRRING & FREEZING switch to the STIRRING & FREEZING position.

C. 24 HOUR TIMER

To program the timer, rotate program disc in the direction of the arrows to align the correct day/time with the time of day mark. Then pull out for Off time or push in for On time. Each actuator is equivalent to 15 minutes time. Check for AM/PM centered between 12 and 12 on rotating disc. At a 6:00 setting the indicator will point to AM or PM.

D. HIGH PRESSURE MANUAL RESET SWITCH

The HIGH PRESSURE MANUAL RESET SWITCH is a safety switch designed to protect the compressor from damage due to excessive head pressure. When tripped, the lever will be out; push to reset.

E. SPIGOT ASSEMBLY

Dispensing of frozen mix is done by the SPIGOT ASSEMBLY. By pulling the spigot plunger out, mix in the form of ice crystals is dispensed through the port on the bottom of the SPIGOT ASSEMBLY. To stop dispensing, push the spigot plunger in.

F. FLAVOR BOTTLES

The FLAVOR BOTTLES are operated by a spring loaded, push-button pump. By pushing down, 1/4 ounce (7.39 ml) of flavor is dispensed.

3.3 DRAINING THE FREEZER FOR DISASSEMBLING AND CLEANING

After installation and initial set-up, the freezer exterior must be cleaned and the freezer parts must be disassembled, cleaned and sanitized. Cleaning and sanitizing MUST be done before the initial freeze down and operation.

Subsequent cleaning and sanitizing, after the freezer has been operated and product has been dispensed, will require the freezer to be completely drained of all unused mix. Perform the following steps to drain the freezer of any unused mix:

- A. Set the STIRRING ONLY-OFF-STIRRING & FREEZING switch to the STIRRING ONLY position well in advance of cleaning and sanitizing to assure complete defrosting and draining of the product cylinder.
- B. While the freezer is in the STIRRING ONLY mode, remove the unused flavoring from the flavor bottles. All unused flavoring should be poured into the containers from which they came.
- C. Remove the Sani-tray and cover by gently pushing up to disengage from the support pins and pulling out and down (Fig. 13).
- D. With a bucket placed below the drain spigot, pull the spigot to dispense (Fig. 14).
- E. When liquid product is completely drained, empty the bucket into the sink. Any remaining ice can be removed by circulating warm water through barrel.

3.4 DISASSEMBLY AND CLEANING OF FREEZER PARTS

CAUTION

PLACE THE ON-OFF-STIR ONLY SWITCH IN THE OFF POSITION AND DISCONNECT THE FREEZER FROM ELECTRICAL SUPPLY SOURCE BEFORE SERVICING OR CLEANING.

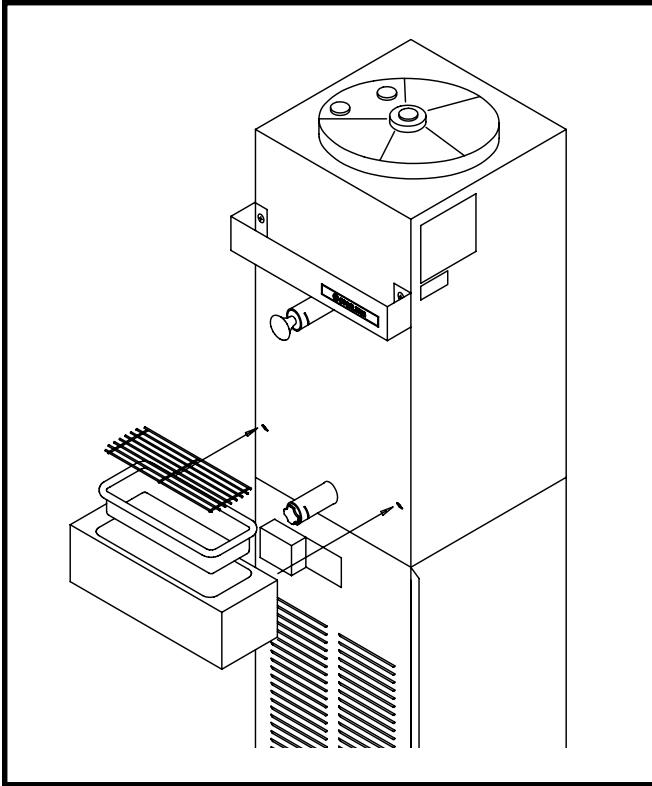

Figure 13
Removing Drip Tray and Cover

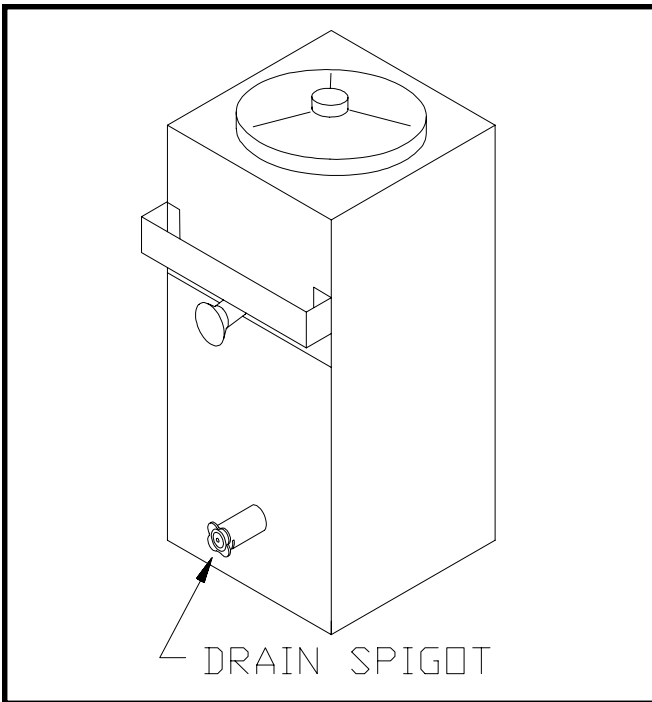

Figure 14
Draining Product

Inspection for worn or broken parts should be made during every disassembly of the freezer for cleaning or other purposes. All worn or broken parts should be replaced to ensure safety to both the operator and the customer, and to maintain good freezer performance as well as a quality product.

NOTE

Frequency of cleaning MUST comply with local health regulations.

The exterior of the freezer must be kept clean at all times to preserve the luster of the stainless steel. A mild alkaline cleanser is recommended. Use a soft cloth or sponge to apply the cleanser.

NOTE

Do not use acid cleaners, strong caustic compounds or abrasive materials to clean any plastic or stainless steel parts of the freezer exterior.

- A. Remove the dispensers from the side of the freezer by pulling straight up. Clean the cup dispensers and dispenser lids with a mild alkaline cleanser and soft cloth or sponge.
- B. Remove the drip tray support, drip tray and drip tray grid by lifting up and out. Clean the drip tray parts in the same manner as the cup dispenser.
- C. Remove the two-piece cover and mix level probe assembly and clean.
- D. Remove the flavor pumps from the bottles and pump warm soapy water through them. Then clean the bottles and pumps normally.
- E. To remove the upper and lower spigot assemblies, remove the retaining clip and pull the spigot assemblies straight out of the product outlet (Fig.15).

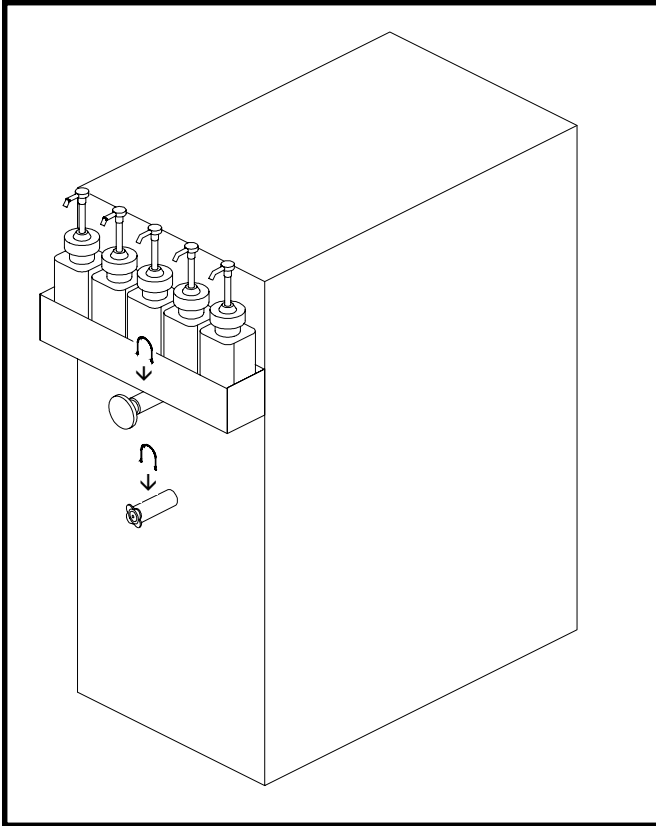

Figure 15
Removing Spigot Assembly

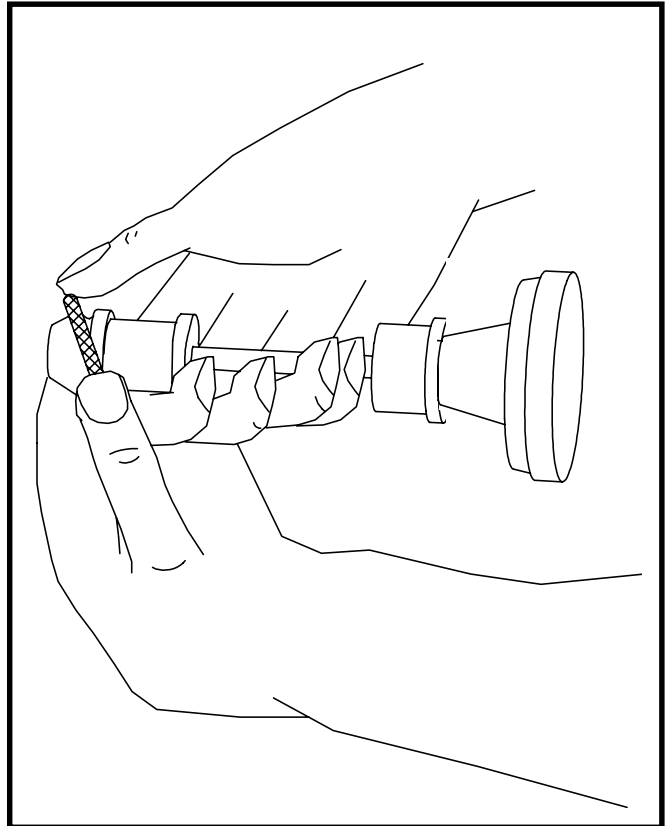

Figure 16
Removing Spigot O-Ring from Spigot body

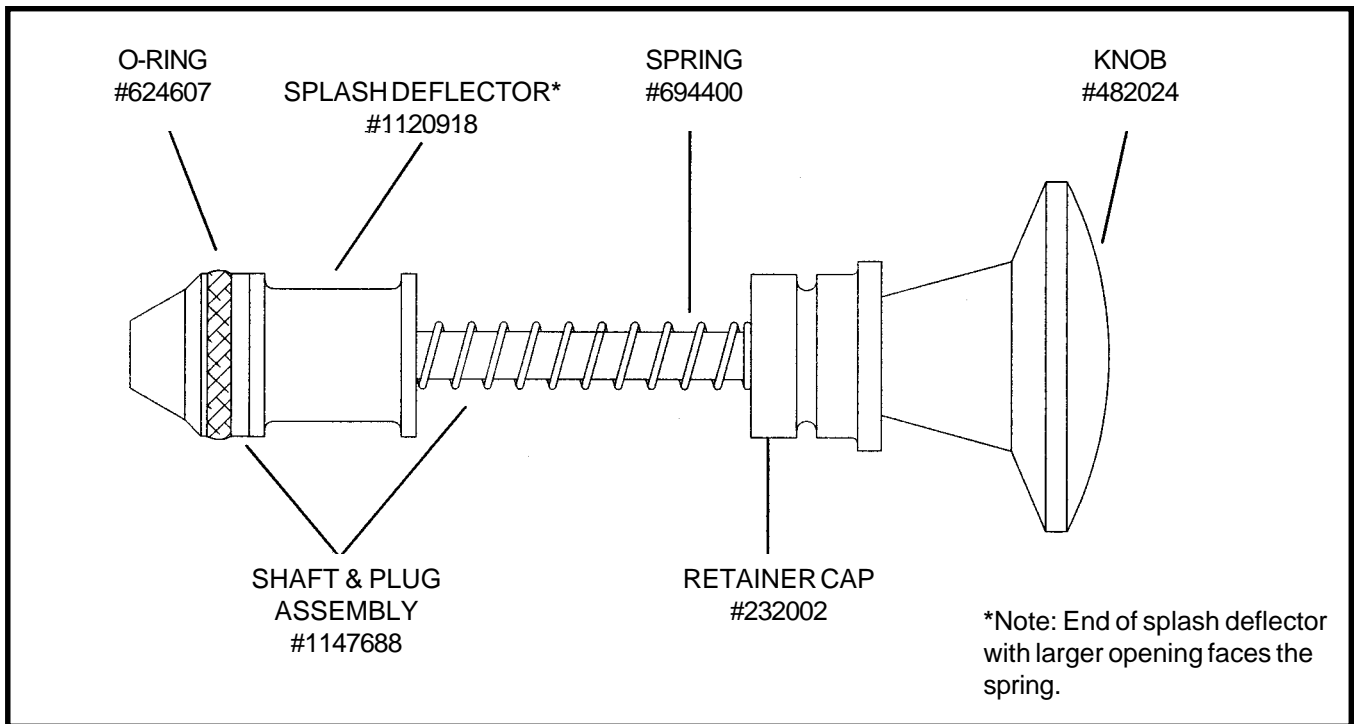

Figure 17
Cut-away View of Spigot Assembly

1. With a clean, dry towel, wipe excess lubricant from the spigot assembly and o-ring. Firmly grasp the spigot assembly with both hands and squeeze the o-ring upward (Fig 16). When a loop is formed, roll the o-ring out of the groove toward the end of the spigot assembly. (See Fig. 17 for a cutaway view of the spigot assembly.)

CAUTION

DO NOT USE ANY TYPE OF SHARP OBJECT TO REMOVE ANY O-RINGS.

2. Place all loose parts in a pan or container and take them to the wash sink, filled with warm, soapy water, for cleaning.
 3. Wash the product outlet with warm soapy water using the brush provided.
- G. For removal and disassembly of the divider plate and agitator assembly, refer to the following steps:

WARNING

PLACE THE ON-OFF-STIR ONLY SWITCH IN THE OFF POSITION AND DISCONNECT THE FREEZER FROM ELECTRICAL SUPPLY SOURCE.

1. Remove the drive cap and O-ring from the agitator tube (Fig.18).

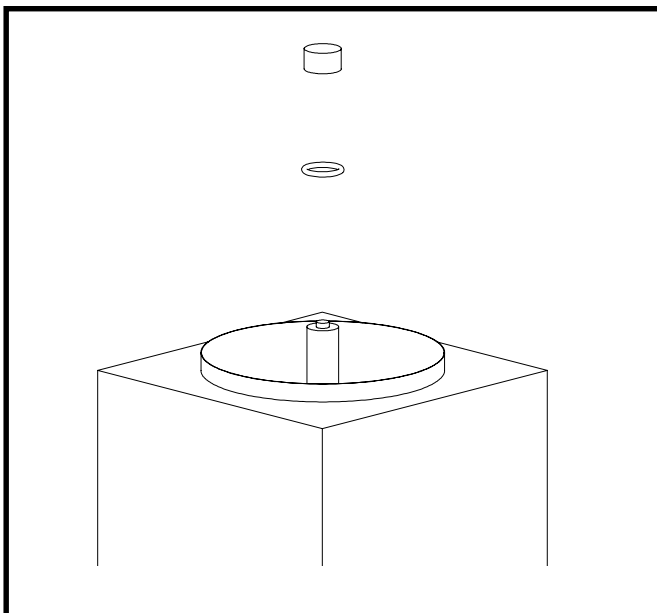

Figure 18
Removing Drive Cap and O-Ring

2. Remove the sealer ring by squeezing the looped section and lifting out of the product cylinder (Fig. 19).

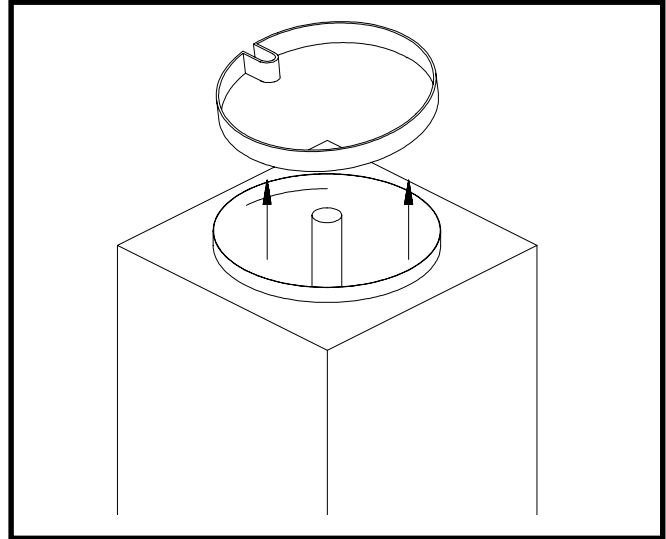

Figure 19
Removing Sealer Ring

3. To remove the divider plate and agitator assembly, the divider plate must be first rotated counterclockwise to unlock and lift out of the product cylinder.
4. Once the divider plate and agitator assembly are lifted off the vertical product cylinder center post and out of the product cylinder, remove the divider plate assembly and anti-lift disc. Remove the plastic agitator bushing from the bottom of the product cylinder center post by lifting up and out of the product cylinder (Fig. 20). - Refer to Figure 23 for an exploded view.

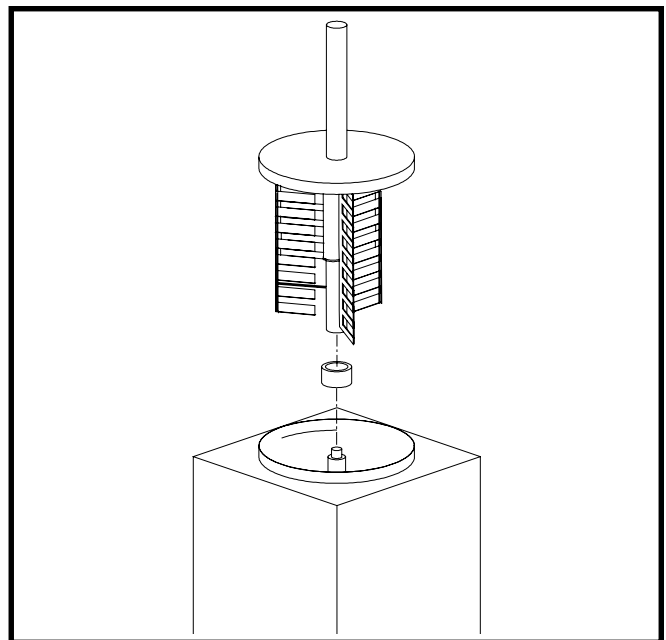

Figure 20
Removing Agitator Assembly and Lower Bushing

5. Unscrew the divider plate from the agitator fingers and remove (Fig.21).

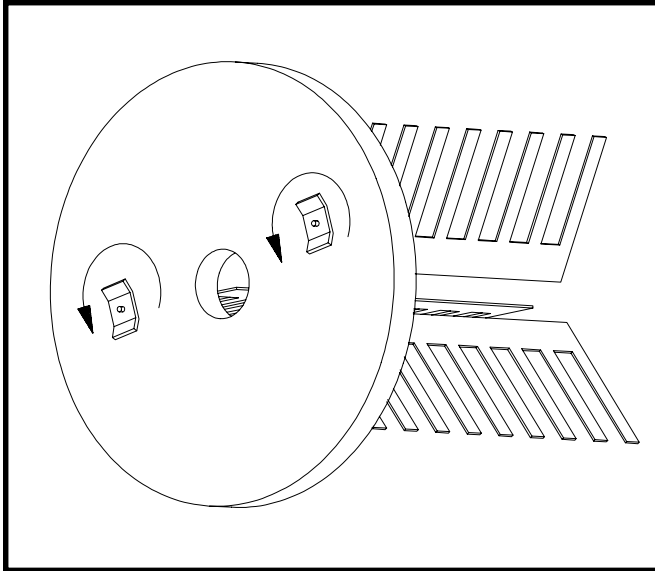

Figure 21
Removing Divider Plate from Agitator Fingers

6. Remove the drive shaft by pulling straight up and out of the vertical center post (Fig.22).

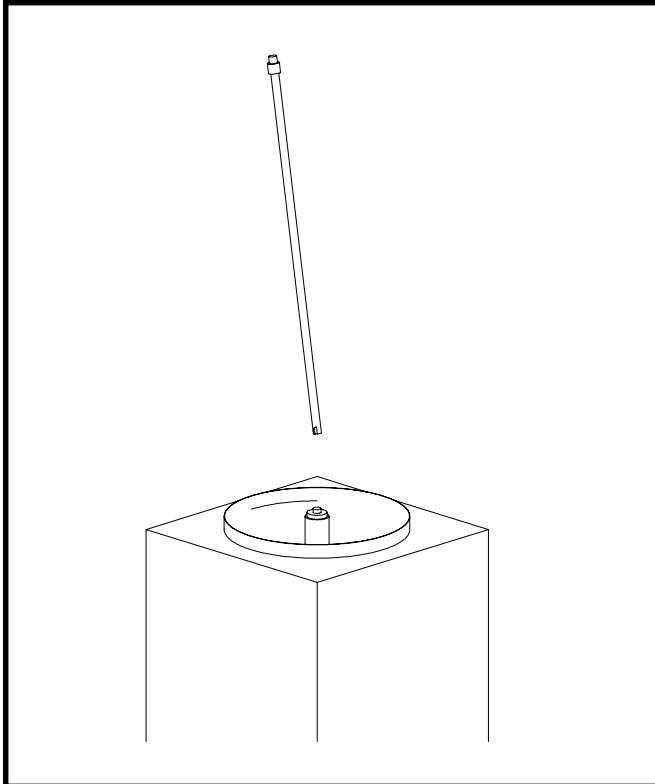

Figure 22
Removing Drive Shaft

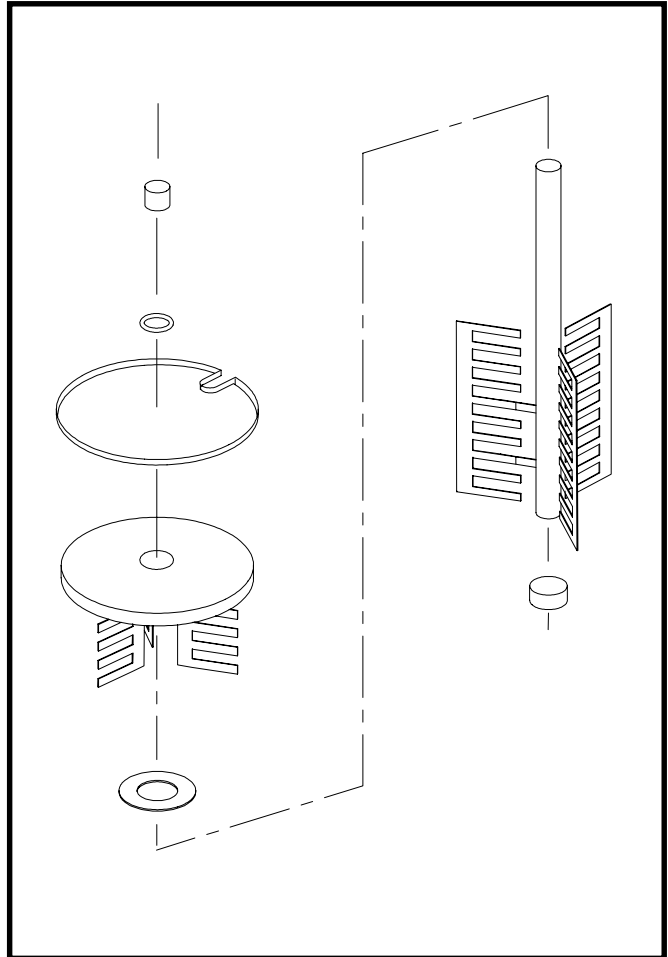

Figure 23
Exploded View of Divider Plate and Agitator Assembly

7. Place all loose parts in a pan or container and take them to the wash sink, filled with warm, soapy water, for cleaning.

CAUTION
DO NOT DAMAGE PARTS BY DROPPING OR ROUGH HANDLING.

NOTE
Do not attempt to wash the inside of the vertical product cylinder center post.

8. Wash the inside of the product cylinder with warm, soapy water, using the brush provided.

3.5 SANITIZING THE FREEZER AND FREEZER PARTS

After the freezer parts have been soaked and washed in warm, soapy water, they should be rinsed thoroughly in clean water.

All parts must be sanitized before assembling with a USDA certified food grade sanitizing solution (50 parts per million of free available chlorine or equivalent is acceptable).

- A. Mix a sanitizing solution of 50 parts per million to sanitize all loose parts before assembling.
- B. Place all loose parts in this solution, then remove and let air dry.
- C. Using this sanitizing solution and the brushes provided, sanitize the product cylinder and product outlet by dipping the brush in the sanitizing solution and scrubbing these areas.
- D. After assembling the freezer (Section 3.6), mix approximately 3 gallons (11.3 liters) of sanitizing solution and pour into the product cylinder. Brush the walls of the cylinder above the divider plate, with brushes provided to sanitize this reservoir area.
- E. Set the STIRRING ONLY-OFF-STIRRING & FREEZING switch in the STIRRING ONLY position and allow to stir for five minutes. Drain the solution in the same manner as draining the product.
- F. Pour approximately one pint (1/2 liter) of mixed neutral base into the product cylinder. Wait one minute, then drain the neutral base and remaining sanitizing solution through the drain spigot.

Sanitizing must be done after the freezer is clean and just before the product cylinder is filled with mixed neutral base. Sanitizing the night before is not effective. However, you should always clean the freezer and parts after use.

WARNING

THE UNITED STATES DEPARTMENT OF AGRICULTURE AND THE FOOD AND DRUG ADMINISTRATION REQUIRE THAT ALL CLEANING AND SANITIZING SOLUTIONS USED WITH FOOD PROCESSING EQUIPMENT BE CERTIFIED FOR THIS USE.

When sanitizing the freezer, refer to local sanitary regulations for applicable codes and recommended disinfecting products and procedures. The frequency of sanitizing must comply with local health regulations.

CAUTION

PROLONGED CONTACT OF SANITIZING SOLUTION WITH FREEZER MAY CAUSE CORROSION OF STAINLESS STEEL PARTS.

3.6 ASSEMBLY OF FREEZER

To assemble the freezer and freezer parts, refer to the following steps:

NOTE

Petro-Gel sanitary lubricant or equivalent must be used when lubrication of parts is specified.

The United States Department of Agriculture and the Food and Drug Administration require that lubricants used on food processing equipment be certified for this use. Use lubricants only in accordance with manufacturers instructions.

- A. Assemble the divider plate and agitator assembly as follows:
 - 1. Before installing the drive shaft, lubricate the bottom with Petro-Gel or any other type of sanitary lubricant. Enough lubricant must be applied to create approximately a 1/8 inch bulge at the bottom of the drive shaft (Fig.24).

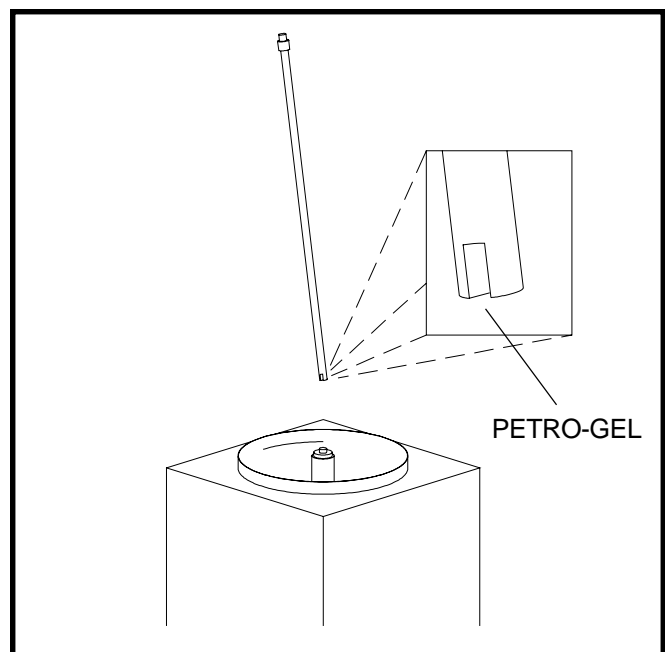

Figure 24. Lubricating Drive Shaft

2. Install the drive shaft into the center post by rotating and pressing down lightly on the shaft until the shaft drops down and engages with the gear box shaft.
3. Replace the plastic lower bushing to the bottom of the vertical center post.
4. Assemble the divider plate to the stationary fingers.
5. Assemble the anti-lift disc onto the agitator (See Fig.23).
6. Slide the divider plate down from the top of the agitator tube, until it is seated properly, allowing the agitator fingers clearance for rotation.
7. Assemble the divider plate and agitator assembly onto the vertical center post, making sure the indicator arrow on the divider plate is in position to line up with the upper spigot. Grasp the agitator tube and slide the assembly down the vertical center post and lock (Fig. 25).

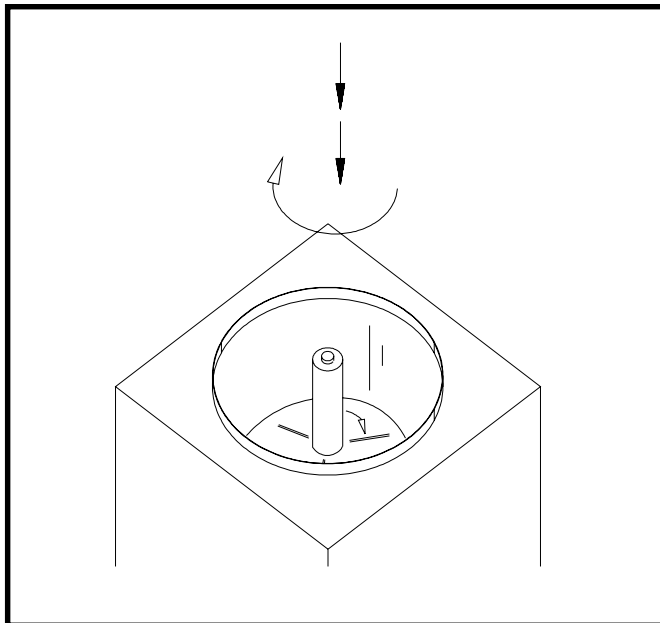

Figure 25
Installing Divider Plate and Agitator Assembly

8. Install the sealer ring by squeezing the looped section and sliding down into the product cylinder.

NOTE

For proper operation of the freezer, the looped section of the sealer ring MUST be positioned to the back of the product cylinder (Fig.26).

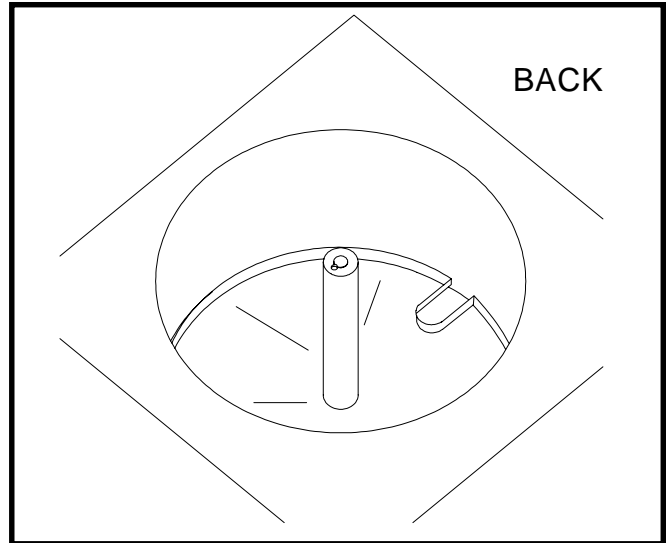

Figure 26
Proper Installation of Sealer Ring

9. Roll the agitator tube "O"-Ring completely down the agitator tube until it seals tightly to the divider plate.
10. Rotate the agitator tube clockwise until the guide hole at the top of the agitator tube forms a complete circle with the hole at the top of the vertical center post (Fig.27).

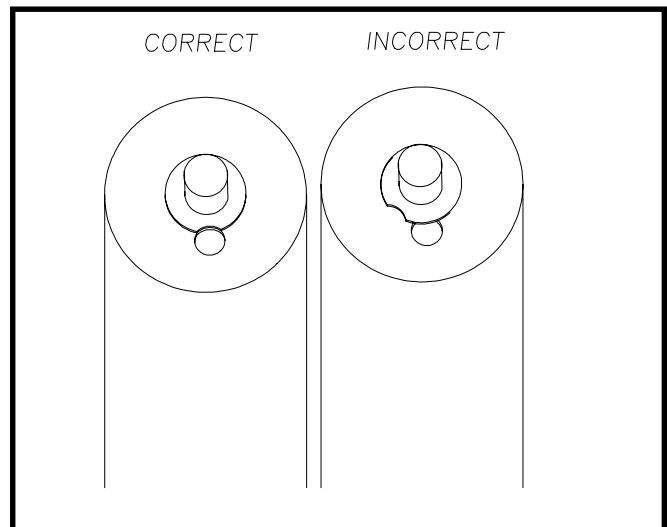

Figure 27
Correct and Incorrect Alignment of Vertical Center Post Guide Hole

11. Assemble the drive cap onto the agitator tube, aligning the guide pin in the drive cap with the guide hole in the vertical center post and pressing down.

- B. Assemble O-rings onto the spigot plungers **without lubricant**. Then apply a thin film of sanitary lubricant to the exposed surfaces of the O-rings.
- 1. Insert the spigot assembly into the product outlet.
- 2. Slide the spigot retaining clip into position.
- C. Assemble the flavor bottles as follows:
 - 1. Replace the bottles in the flavor rack.
- D. Install sani-tray and cover.
- E. Replace the cup dispensers on the side of the freezer by positioning the bracket on the dispenser above the bracket on the side of the freezer and sliding down.

3.7 MIX INFORMATION

It is essential to follow the mixing instructions on the neutral base container carefully. The concentration of ingredients in the product, which determines the "Brix" (sugar level), is very important to the operation of the freezer and the quality of the drink. When the proper amount of neutral base is mixed with the proper amount of water, the mixture should have a "Brix" reading between 11 and 13.

CAUTION

DO NOT POUR THE INDIVIDUAL INGREDIENTS (WATER OR NEUTRAL BASE) DIRECTLY INTO THE FREEZER AND DEPEND ON THE AGITATOR TO DO THE MIXING. THIS DOES NOT PROVIDE FOR ADEQUATE MIXING AND MAY CAUSE DAMAGE TO THE FREEZER.

Refer to the following steps for filling the freezer:

- A. Follow instructions on neutral base containers to mix neutral base with water. Then pour into the freezer.
- B. The product cylinder has a 10 gallon capacity, when filled approximately 1" (2.54 cm) from the top of the cylinder. When filling the cylinder, it is necessary to remove all trapped air from below the divider plate.

Fill the product cylinder with mix to within 1" (2.54 cm) from the top. Place a sanitary container under the serving spigot and dispense small amounts of liquid by pulling out and pushing in the spigot in a series of short bursts. Each time the spigot is closed, bubbles will rise to the top of the liquid in the product cylinder. When no more bubbles rise to the top, the air trapped under the divider plate has been removed. Pour the contents of the

container back into the product cylinder.

3.8 FREEZE DOWN AND OPERATION

- A. With mixed neutral base in the product cylinder, start the freezing process by setting the STIRRING ONLY-OFF-STIRRING & FREEZING switch in the STIRRING & FREEZING position.
- B. Although servable product can be obtained after the freezer has been run for 1 hour, the best quality ice crystals will develop after the freezer has been running for several more hours.

3.9 DISPENSING PRODUCT

To dispense product correctly, refer to the following steps:

- A. Select the desired cup size.
- B. Dispense flavor concentrate into the cup first, by pushing the flavor pump down. Use one squirt of flavor for small cups, two squirts for medium cups and three squirts for large cups.
- C. Place cup under and against the spigot.
- D. Pull the spigot out.
- E. Fill the cup. The gravity flow from the spigot will automatically mix the flavor concentrate with the neutral base mixture as it is dispensed.
- F. When the cup is full, push the spigot in.

3.10 ROUTINE CLEANING

To remove spilled or dried mix from the freezer exterior, simply wash in the direction of the finish with warm soapy water or a mild alkaline cleanser and a soft cloth or sponge. Do not use abrasive materials as they will mar the finish of the freezer.

Refer to Figure 28 for all external parts of the freezer to be cleaned.

3.11 PREVENTATIVE MAINTENANCE

It is recommended that the following maintenance schedule be followed to keep the freezer clean and operating properly.

CAUTION

NEVER ATTEMPT TO REPAIR OR PERFORM MAINTENANCE ON THE FREEZER UNTIL THE MAIN ELECTRICAL POWER HAS BEEN DISCONNECTED.

A. DAILY

1. The exterior should be kept clean at all times to preserve the lustre of the stainless steel. A mild alkaline cleanser is recommended. Use a soft cloth or sponge to apply the cleanser.

CAUTION

DO NOT USE ACID CLEANERS, STRONG CAUSTIC COMPOUNDS OR ABRASIVE MATERIALS TO CLEAN ANY PART OF THE FREEZER EXTERIOR OR PLASTIC PARTS.

2. Clean the sani-tray by lifting up, out, and rinsing and replacing.

B. WEEKLY

1. Check all "O" Rings for excessive wear and replace if necessary.

C. MONTHLY

CAUTION

THE FREEZER HAS AN AIR COOLED CONDENSER AND MUST HAVE PROPER AIR CIRCULATION.

DO NOT PLACE THE E257 FLOOR MODEL FREEZER ANY CLOSER THAN SIX (6) INCHES (15.2 CM) FROM THE WALL.

THE COUNTER MODEL FREEZER REQUIRES A 3" (7.6 CM) CLEARANCE ON THE SIDES, A 1" (2.5 CM) CLEARANCE AT THE REAR, AND A 10" (25.4 CM) CLEARANCE AT THE TOP.

FAILURE TO CLEAN THE CONDENSER FILTER MAY RESULT IN SERIOUS FREEZER DAMAGE AND COULD VOID THE WARRANTY.

CONDENSER CLEANING

1. For the floor models, remove the sani-tray and insert. Remove the two phillips head screws from the lower front panel and pull panel down and out. Blow the dirt out from the opposite side of the condenser using an air tank, CO₂ tank, or vacuum.
2. For the counter model, remove the six phillips head screws from the back panel. Then clean the condenser using the same method as on the floor model.

3.12 EXTENDED STORAGE

Refer to the following steps for storage of the freezer over any long period of time:

- A. Place the STIRRING ONLY-OFF-STIRRING & FREEZING switch in the OFF position.
- B. Disconnect (unplug) the freezer from the electrical supply source.
- C. With a warm detergent solution, thoroughly clean all parts that come in contact with neutral base mix or flavors. Rinse in clear water and dry all parts. Do not sanitize.

NOTE

Do not let cleaning solution or products stand in the product cylinder during shutdown period.

- D. Remove, disassemble and clean the spigot assemblies and lower bushing. Place these parts in a plastic bag with a moist paper towel to prevent them from becoming brittle.

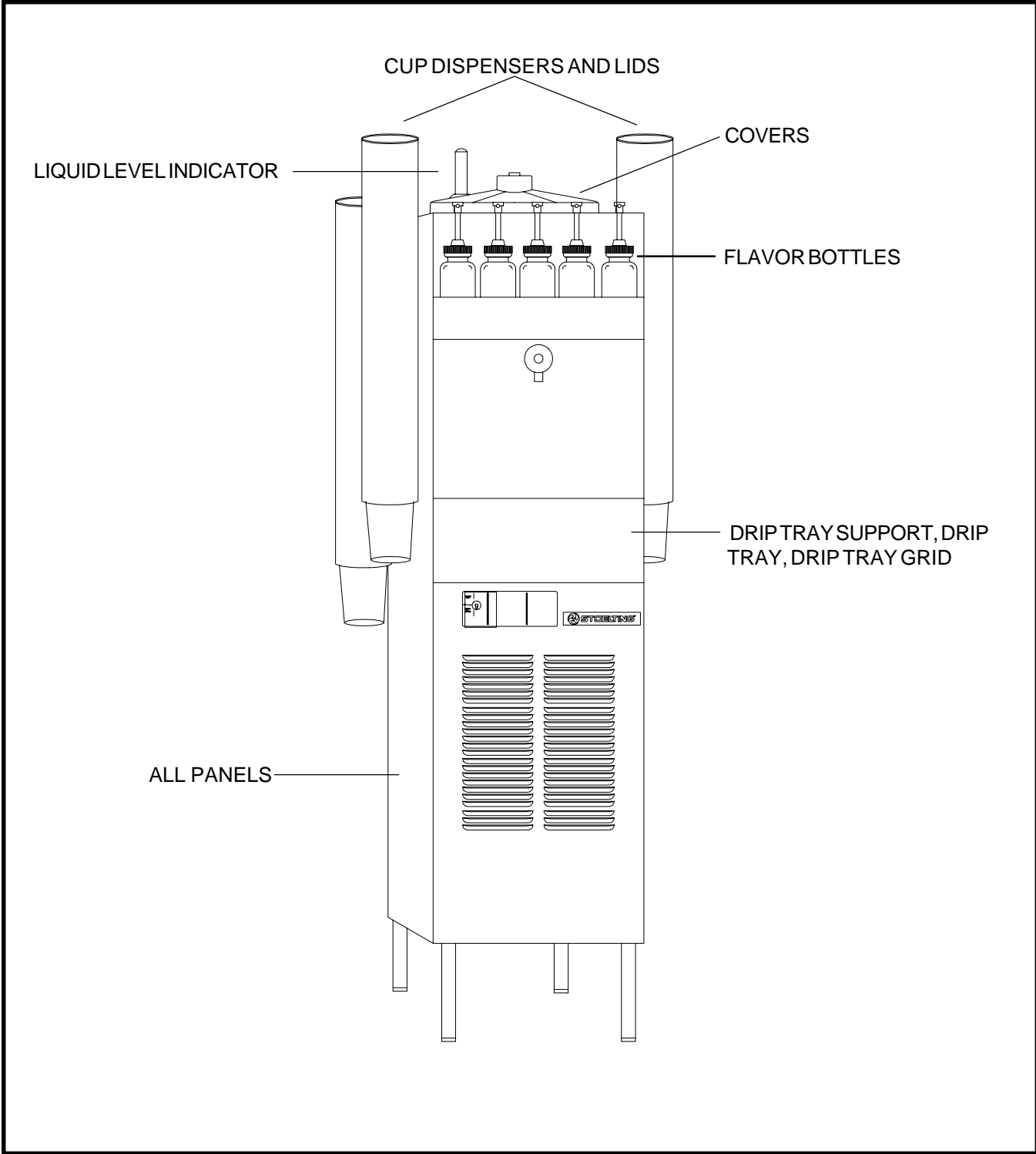

Figure 28
External Parts To Be Cleaned

**SECTION 4
DECALS AND TAGS**

4.1 HOW TO ORDER DECALS AND TAGS

To assure receipt of the proper warning decals, supply your dealer or distributor with the following information:

- A. Model number of equipment.
- B. Serial number of model, stamped on nameplate.
- C. Part number, decal description and quantity needed. Common warning decal names and numbers are listed below.

DECALS AND TAGS FOR MODELS E157A / E257A	
PART NUMBER	DESCRIPTION
324105	DECAL CAUTION: ELECTRIC SHOCK
324107	DECAL CAUTION: MOVING PARTS
324113	DECAL CAUTION: GROUNDED PLUG
324135	DECAL TOGGLE & SAFETY SWITCH
324200	DECAL MANUAL RESET
324393	DECAL STOELTING SWIRL
324548	DECAL ADEQUATE VENTILATION - E257/F257 Floor Model
324585	DECAL REFRIGERATION CHARGE
324649	DECAL ADEQUATE VENTILATION - E157 - Counter Model
723516	TAG ATTN: SET TIMER
723526	TAG READ MANUAL
723529	TAG CAUTION
723537	TAG SANITARY CLEAN



**WARRANTY
FROZEN UNCARBONATED BEVERAGE EQUIPMENT**

1. **Scope:**
PW Stoelting, L.L.C. (“Stoelting”) warrants to the first user (the “Buyer”) that the evaporator assembly, compressors, drive motors, and speed reducers of Stoelting frozen uncarbonated beverage equipment will be free from defects in materials and workmanship under normal use and proper maintenance appearing within five (5) years, and that all other components of such equipment manufactured by Stoelting will be free from defects in material and workmanship under normal use and proper maintenance appearing within twelve (12) months after the date that such equipment is originally installed.

2. **Disclaimer of Other Warranties:**

THIS WARRANTY IS EXCLUSIVE; AND STOELTING, HEREBY DISCLAIMS ANY IMPLIED WARRANTY OF MERCHANTABILITY OR FITNESS FOR PARTICULAR PURPOSE.

3. **Remedies:**
Stoelting’s sole obligations, and Buyer’s sole remedies, for any breach of this warranty shall be the repair or (at Stoelting’s option) replacement of the affected component at Stoelting’s plant in Kiel, Wisconsin, or (again, at Stoelting’s option) refund of the purchase price of the affected equipment, and, during the first twelve (12) months of the warranty period, deinstallation/reinstallation of the affected component from/into the equipment. Those obligations/remedies are subject to the conditions that Buyer (a) signs and returns to Stoelting, upon installation, the Start-Up and Training Checklist for the affected equipment, (b) gives Stoelting prompt written notice of any claimed breach of warranty within the applicable warranty period, and (c) delivers the affected equipment to Stoelting or its designated service location, in its original packaging/crating, also within that period. Buyer shall bear the cost and risk of shipping to and from Stoelting’s plant or designated service location.

4. **Exclusions and Limitations:**
This warranty does not extend to parts, sometimes called “wear parts”, which are generally expected to deteriorate and to require replacement as equipment is used, including as examples but not intended to be limited to o-rings, hoses, seals, and drive belts. All such parts are sold

AS IS.

Further, Stoelting shall not be responsible to provide any remedy under this warranty with respect to any component that fails by reason of negligence, abnormal use, misuse or abuse, use with parts or equipment not manufactured or supplied by Stoelting, or damage in transit.

THE REMEDIES SET FORTH IN THIS WARRANTY SHALL BE THE SOLE LIABILITY STOELTING AND THE EXCLUSIVE REMEDY OF BUYER WITH RESPECT TO EQUIPMENT SUPPLIED BY STOELTING; AND IN NO EVENT SHALL STOELTING BE LIABLE FOR ANY INCIDENTAL OR CONSEQUENTIAL DAMAGES, WHETHER FOR BREACH OF WARRANTY OR OTHER CONTRACT BREACH, NEGLIGENCE OR OTHER TORT, OR ON ANY STRICT LIABILITY THEORY.