



Model F212
OPERATORS MANUAL

Manual No. 513675

Rev.0

This manual provides basic information about the machine. Instructions and suggestions are given covering its operation and care.

The illustrations and specifications are not binding in detail. We reserve the right to make changes to the machine without notice, and without incurring any obligation to modify or provide new parts for machines built prior to date of change.

DO NOT ATTEMPT to operate the machine until instructions and safety precautions in this manual are read completely and are thoroughly understood. If problems develop or questions arise in connection with installation, operation, or servicing of the machine, contact Stoelting.



stoeltingfoodservice.com

Stoelting Foodservice Equipment
502 Highway 67
Kiel, WI 53042-1600
U.S.A.

Main Tel: 800.558.5807
Fax: 920.894.7029

Customer Service: 888.429.5920
Fax: 800.545.0662
Email: foodservice@stoelting.com

© 2014 PW Stoelting, LLC

A Few Words About Safety

Safety Information

Read and understand the entire manual before operating or maintaining Stoelting equipment.

This manual provides the operator with information for the safe operation and maintenance of Stoelting equipment. As with any machine, there are hazards associated with their operation. For this reason safety is emphasized throughout the manual. To highlight specific safety information, the following safety definitions are provided to assist the reader.

The purpose of safety symbols is to attract your attention to possible dangers. The safety symbols, and their explanations, deserve your careful attention and understanding. The safety warnings do not by themselves eliminate any danger. The instructions or warnings they give are not substitutes for proper accident prevention measures.

If you need to replace a part, use genuine Stoelting parts with the correct part number or an equivalent part. We strongly recommend that you do not use replacement parts of inferior quality.



Safety Alert Symbol:

This symbol Indicates danger, warning or caution. Attention is required in order to avoid serious personal injury. The message that follows the symbol contains important information about safety.

Signal Word:

Signal words are distinctive words used throughout this manual that alert the reader to the existence and relative degree of a hazard.



The signal word "WARNING" indicates a potentially hazardous situation, which, if not avoided, may result in death or serious injury and equipment/property damage.



The signal word "CAUTION" indicates a potentially hazardous situation, which, if not avoided, may result in minor or moderate injury and equipment/property damage.

CAUTION

The signal word "CAUTION" not preceded by the safety alert symbol indicates a potentially hazardous situation, which, if not avoided, may result in equipment/property damage.

NOTE (or NOTICE)

The signal word "NOTICE" indicates information or procedures that relate directly or indirectly to the safety of personnel or equipment/property.

TABLE OF CONTENTS

Section	Description	Page
1	Description and Specifications	
1.1	Description.....	1
1.2	Specifications	2
2	Installation Instructions	
2.1	Safety Precautions	3
2.2	Shipment and Transit.....	3
2.3	Machine Installation.....	3
3	Initial Set-Up and Operation	
3.1	Operator's Safety Precautions	5
3.2	Operating Controls and Indicators	5
3.3	Assembly of Machine	6
3.4	Sanitizing	7
3.5	Freeze Down and Operation	8
3.6	Mix Information	8
3.7	Removing Mix From Machine.....	8
3.8	Cleaning the Machine.....	8
3.9	Disassembly of Machine Parts	8
3.10	Cleaning and Sanitizing The Machine Parts.....	9
3.11	Sanitize Machine	9
3.12	Routine Cleaning	9
3.13	Preventive Maintenance	10
3.14	Extended Storage.....	10
4	Troubleshooting	
4.1	Light Indicators	11
4.2	Troubleshooting.....	11
5	Replacement Parts	
5.1	Brushes, Decals, and Lubrication.....	13
5.2	Auger Shaft and Faceplate Parts	14
5.3	Hopper Parts	15

SECTION 1 DESCRIPTION AND SPECIFICATIONS

1.1 DESCRIPTION

The Stoelting F212 floor model machine is gravity fed. The machine is equipped with fully automatic controls to provide a uniform product. The machine will operate with almost any type of shake mix. This manual is designed to help qualified service personnel and operators with the installation, operation and maintenance of the Stoelting F212 gravity machine.



Figure 1-1 Model F212

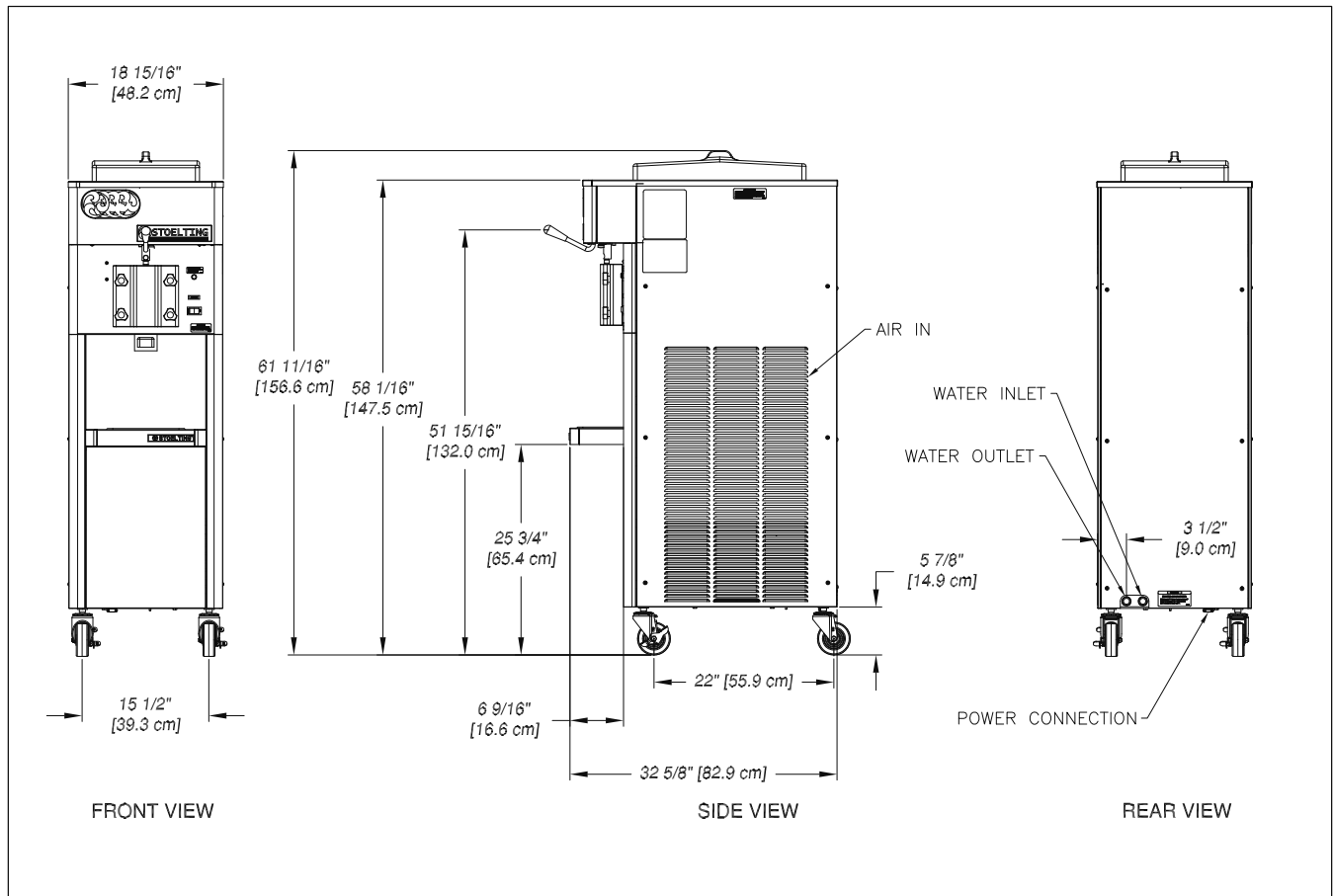

1.2 SPECIFICATIONS

F212		
Dimensions	Machine	with crate
width	18-1/4" (46,4 cm)	25" (63,5 cm)
height	64-1/2" (163,8 cm)	66" (167,6 cm)
depth	33" (83,8 cm)	51" (129,5 cm)
Weight	315 lbs (142,8 kg)	410 lbs (185,9 kg)
Electrical	1 Phase, 208-240 VAC, 60Hz	
running amps	10A	
connection type	NEMA6-20P power cord provided	
Compressor	12,000 Btu/hr	
Drive Motor	3/4 hp	
Air Flow	Air cooled units require 3" (7,6 cm) air space on both sides	
Plumbing Fittings	Water cooled units require 3/8" N.P.T. water and drain fittings	
Hopper Volume	7 gallon (26,50 liters)	
Freezing Cylinder Volume	2 gallon (7,57 liters)	

SECTION 2 INSTALLATION INSTRUCTIONS

2.1 SAFETY PRECAUTIONS

Do not attempt to operate the machine until the safety precautions and operating instructions in this manual are read completely and are thoroughly understood.

Take notice of all warning labels on the machine. The labels have been put there to help maintain a safe working environment. The labels have been designed to withstand washing and cleaning. All labels must remain legible for the life of the machine. Labels should be checked periodically to be sure they can be recognized as warning labels.

If danger, warning or caution labels are needed, indicate the part number, type of label, location of label, and quantity required along with your address and mail to:

STOELTING, INC.
ATTENTION: Customer Service
502 Hwy. 67
Kiel, Wisconsin 53042

2.2 SHIPMENT AND TRANSIT

The machine has been assembled, operated and inspected at the factory. Upon arrival at the final destination, the entire machine must be checked for any damage which may have occurred during transit.

With the method of packaging used, the machine should arrive in excellent condition. **THE CARRIER IS RESPONSIBLE FOR ALL DAMAGE IN TRANSIT, WHETHER VISIBLE OR CONCEALED.** Do not pay the freight bill until the machine has been checked for damage. Have the carrier note any visible damage on the freight bill. If concealed damage and/or shortage is found later, advise the carrier within 10 days and request inspection. The customer must place claim for damages and/or shortages in shipment with the carrier. Stoelting, Inc. cannot make any claims against the carrier.

2.3 MACHINE INSTALLATION

Installation of the machine involves moving the machine close to its permanent location, removing all crating, setting in place, assembling parts, and cleaning.

- A. Uncrate the machine.
- B. Accurate leveling is necessary for correct drainage of machine barrel and to insure correct overrun. Place a bubble level on top of the machine at each corner to check for level condition. If adjustment is necessary, level the machine by turning the caster leveling nut in or out then tightening the locking nut.



Figure 2-2 Space and Ventilation Requirements

- C. Correct ventilation is required. The F212 requires 3" clearance on both sides for proper air flow.

CAUTION

Failure to provide adequate ventilation will void warranty.

- D. Place the CLEAN-ON-OFF switch in the OFF position.
- E. Connect the power cord to the proper power supply. The plug on the F212 is designed for 208-240VAC / 20 amp duty. Check the nameplate on your machine for proper supply. The unit must be connected to a properly grounded receptacle. The electrical cord furnished as part of the machine has a three prong grounding type plug. The use of an extension cord is not recommended, if necessary use one with a size 12 gauge or heavier with ground wire. Do not use an adapter to get around grounding requirement.

WARNING

Do not alter or deform electrical plug in any way. Altering the plug to fit into an outlet of different configuration may cause fire, risk of electrical shock, product damage and will void warranty.

SECTION 3 OPERATION

3.1 OPERATOR'S SAFETY PRECAUTIONS

SAFE OPERATION IS NO ACCIDENT; observe these rules:

- A. Know the machine. Read and understand the Operating Instructions.
- B. Notice all warning labels on the machine.
- C. Wear proper clothing. Avoid loose fitting garments, and remove watches, rings or jewelry that could cause a serious accident.
- D. Maintain a clean work area. Avoid accidents by cleaning up the area and keeping it clean.
- E. Stay alert at all times. Know which switch, push button or control you are about to use and what effect it is going to have.
- F. Disconnect electrical cord for maintenance. Never attempt to repair or perform maintenance on the machine until the main electrical power has been disconnected.
- G. Do not operate under unsafe operating conditions. Never operate the machine if unusual or excessive noise or vibration occurs.

3.2 OPERATING CONTROLS AND INDICATORS

Before operating the machine, it is required that the operator know the function of each operating control. Refer to Figure 3-1 for the location of the operating controls on the machine.

WARNING

High voltage will shock, burn or cause death. The OFF-ON switch must be placed in the OFF position prior to disassembling for cleaning or servicing. Do not operate machine with cabinet panels removed.

A. Spigot Switch

The spigot switch will automatically start the auger drive and refrigeration systems when the spigot is opened to dispense product. When the spigot is closed, the drive motor and compressor will remain on until the product in the freezing cylinder reaches the proper consistency..

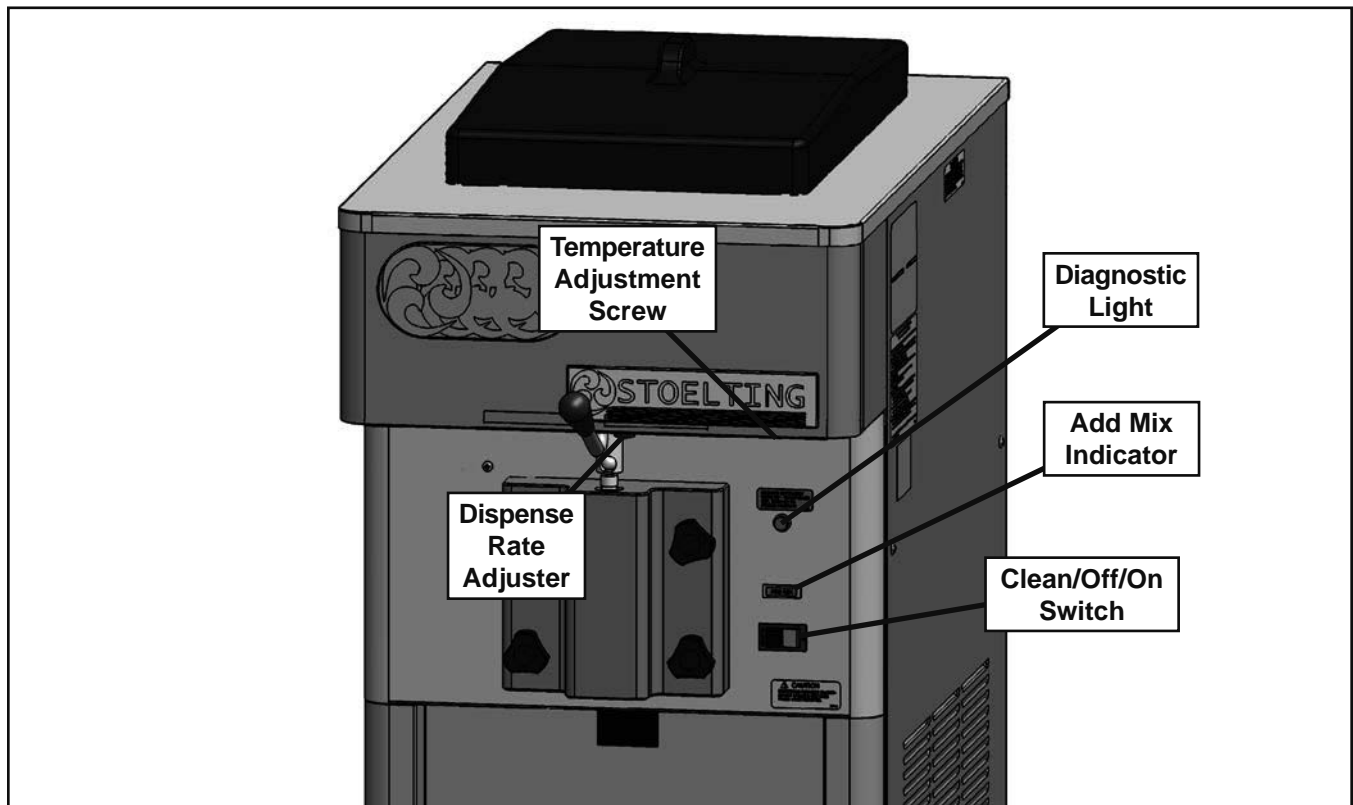

Figure 3-1 Controls

B. CLEAN-OFF-ON Switch

The CLEAN-OFF-ON switch is used to supply power to the control circuit. When the switch is in the OFF (middle) position, power will not be supplied to the control board or refrigeration system. When the switch is in the ON position, the machine will operate in the freezing mode. The hopper agitator operates on timers along with hopper refrigeration. When the switch is in the CLEAN position, all refrigeration will stop, the hopper agitator will stop and the auger will start rotating.

C. ADD MIX Light

The ADD MIX light will flash to alert the operator to a low mix condition. It does so by monitoring the mix level in the hopper. When the ADD MIX light is flashing, refill hopper immediately.

NOTE

Failure to refill the hopper immediately may result in operational problems.

D. Diagnostic Light

The Diagnostic Light will remain on during standby mode. It will flash if an error occurs. The light will flash once if there is a compressor error. There will be two quick flashes if there is a drive motor error. And there will be three quick flashes if the machine is left in clean mode for more than 20 minutes. Refer to the troubleshooting section for details.

E. Temperature Adjustment Screw

The Temperature Adjustment Screw is located under the header panel. It is used to increase or decrease product temperature. When setting the temperature, adjust the screw 1/8 of a turn and retest before making another adjustment (use the markings on the decal on the underside of the header panel). Turn it to the right to decrease temperature or to the left to increase temperature.

F. Front Door Safety Switch

The front door safety switch prevents the auger from turning when the front door is removed. The switch is open when the door is not in place and closed when the door is properly installed.

G. Dispense Rate Adjuster

The dispense rate adjuster limits the opening of the spigot and is located under the header panel, to the immediate right of the spigot handle. Turning the knob counterclockwise will decrease the dispense rate.

3.3 ASSEMBLY OF MACHINE

All parts should be cleaned, sanitized and allowed to air dry before assembling.

To assemble the machine parts, refer to the following steps:

NOTE

Petrol Gel sanitary lubricant or equivalent must be used when lubrication of parts is specified.

NOTE

The United States Department of Agriculture and the Food and Drug Administration require that lubricants used on food processing equipment be certified for this use. Use lubricants only in accordance with the manufacturer's instructions.

- A. Assemble the o-rings onto the spigot dry, without lubrication. Then apply a thin film of sanitary lubrication to the exposed surfaces of the o-rings. Also apply a thin film of sanitary lubricant to the inside and outside of the front auger support bushing.
- B. Put the rear seal o-ring onto the back of the auger and generously lubricate with Petrol-Gel. Assemble the rear seal onto the auger with the large end to the rear.
- C. Put a small amount of spline lubricant on the hex end of the auger shaft. A small container of spline lubricant is shipped with the machine.

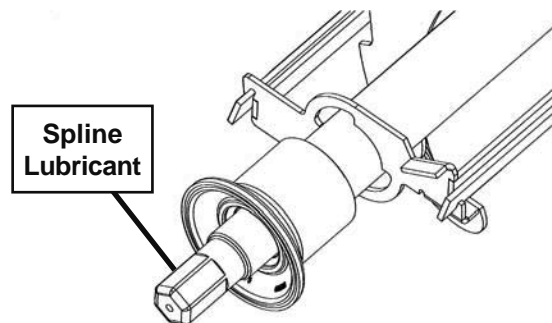

Figure 3-2 Spline Lubricant on Auger

- D. Install the plastic auger blades onto the auger.
- E. Push the auger into the freezing cylinder and rotate it slowly until the auger engages the drive shaft.
- F. Insert the spigot body into the front door.
- G. Install the auger support bushing onto the auger.
- H. Install the front door onto the machine and install the knobs. Tighten the knobs in a crisscross pattern.

- I. Look for the proper seal between the freezing cylinder, front door o-ring, and front door.
- J. Install the mix inlet regulator into the hopper.

CAUTION

Do not place the mix inlet regulator into the hopper before installing the auger. Attempting to install the auger with the mix inlet regulator in place will damage the regulator.

- K. Insert the bushing into the bottom of the hopper agitator and put the agitator onto the shaft in the hopper. Align the guide hole in the shaft and agitator. Place the drive cap onto the agitator so that the pin fits into the guide hole

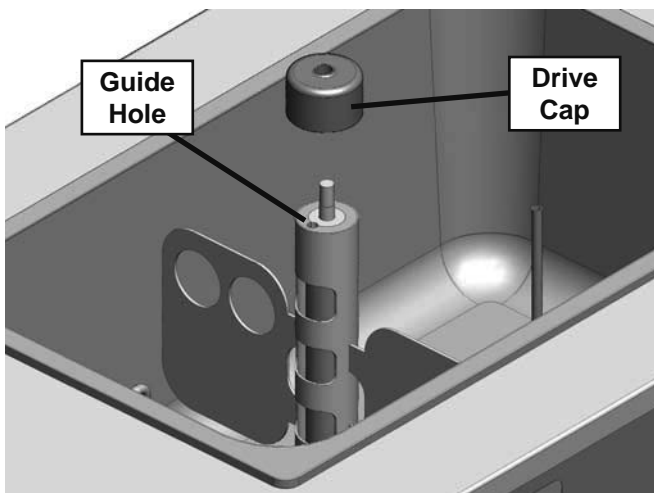

Figure 3-3 Hopper Agitator and Drive Cap

- L. Install the hopper cover, drain tray, drip tray, and drip tray grid.

3.4 SANITIZING

Sanitizing must be done after the machine is cleaned and just before the hopper is filled with mix. Sanitizing the night before is not effective. However, you should always clean the machine and parts after each use.

The United States Department of Agriculture and the Food and Drug Administration require that all cleaning and sanitizing solutions used with food processing equipment be certified for this use.

When sanitizing the machine, refer to local sanitary regulations for applicable codes and recommended sanitizing products and procedures. The frequency of sanitizing must comply with local health regulations.

Mix sanitizer according to manufacturer's instructions to provide a 100 parts per million (ppm) strength solution and check the solution with chlorine test strips. Allow sanitizer to contact the surfaces to be sanitized for 5 minutes. Any sanitizer must be used only in accordance with the manufacturer's instructions.

CAUTION

Do not allow sanitizer to remain in contact with stainless steel parts for prolonged periods. Prolonged contact of sanitizer with machine may cause corrosion of stainless steel parts.

In general, sanitizing may be conducted as follows:

- A. Prepare Stera-Sheen Green Label Sanitizer or equivalent according to manufacturer's instructions to provide a 100 ppm strength solution. Mix the sanitizer in quantities of no less than 2 gallons of 90° to 110°F (32° to 43°C) water. Check the strength of the sanitizing solution. Use a chlorine test strip and color chart to make sure the solution has 100 ppm. Any sanitizer must be used only in accordance with the manufacturer's instructions.
- B. Place the mix inlet regulator into hopper.
- C. Insert the bushing into the bottom of the hopper agitator and put the agitator onto the shaft in the hopper. Align the guide hole in the shaft and agitator. Place the drive cap onto the agitator so that the pin fits into the guide hole.
- D. Pour the sanitizing solution into the hopper and wait until the freezing cylinder is filled. Check for leaks.
- E. While the freezing cylinder fills, clean the sides of the hopper, the agitator, the mix inlet regulator and the underside of the hopper cover using a soft bristle brush dipped in the sanitizing solution.
- F. Place the switch in the CLEAN position.
- G. After five minutes, place a bucket under the spigot and open the spigot to drain the sanitizing solution. Leave a small amount of the sanitizing solution in the freezing cylinder. Place the switch in the OFF (middle) position.
- H. Collect the remaining sanitizing solution in a cup and test the chlorine contents with a new test strip. A reading of 100 ppm or more is acceptable.
If the reading is less than 100 ppm, sanitize the machine again.
If the reading is less than 100 ppm after sanitizing the second time, disassemble and wash the machine again.

3.5 FREEZE DOWN AND OPERATION

This section covers the recommended operating procedures for the safe operation of the machine.

- A. Sanitize just prior to use.
- B. Place the switch in the OFF (middle) position.
- C. Fill the hopper with pre-chilled liquid mix (40°F or 4°C).

NOTE

Do not overfill the hopper. Mix level must be below the air inlet tube on the mix inlet regulator.

- D. Open spigot and drain a small amount of mix to remove any remaining sanitizer.
- E. Allow the freezing cylinder to fill at least halfway. Place the switch in the ON position.

NOTE

After the drive motor starts, there is a 3 or 4 second delay before the compressor starts.

- F. After 8 to 12 minutes the product will be at consistency and will be ready to serve. Freeze down time may vary depending on mix type and ambient temperatures.
- G. To dispense, pull the spigot handle down to open the spigot.
- H. The machine is designed to dispense the product at a reasonable draw rate. If the machine is overdrawn, the result is a liquid product. If this should occur, allow the machine adequate time to recover before dispensing additional product.
- I. Do not operate the machine when the ADD MIX light is on. Refill the hopper immediately.

3.6 MIX INFORMATION

Mix can vary considerably from one manufacturer to another. Differences in the amount of butterfat content and quantity and quality of other ingredients have a direct bearing on the finished frozen product. A change in machine performance that cannot be explained by a technical problem may be related to the mix.

Proper product serving temperature varies from one manufacturer's mix to another. Shake mixes generally provide satisfactory product from 24° to 28°F (-4° to -2°C).

When checking the temperature, stir the thermometer in the frozen product to obtain an accurate reading.

Old mix or mix that has been stored at elevated temperatures will produce poor-quality product with a bad taste and unacceptable appearance. To retard bacteria growth in dairy based mixes, the best storage temperature range is between 33° to 38°F (0.5° to 3.3°C).

Some shake mixes tend to foam more than others. If foam appears in the hopper, skim off with a sanitized utensil and discard.

3.7 REMOVING MIX FROM MACHINE

To remove the mix from the machine, refer to the following steps:

- A. Pull the mix inlet regulator straight up and remove it from the hopper.
- B. Place the switch in the CLEAN position to rotate the auger.
- C. Drain the mix by opening the spigot. A container should be placed under the spigot to collect the mix.
- D. Place the switch in the OFF (middle) position.

3.8 CLEANING THE MACHINE

NOTE

The frequency of cleaning the machine and machine parts must comply with local health regulations.

After the mix has been removed from the machine, the machine must be cleaned. To clean the machine, refer to the following steps:

- A. Close the spigot and fill the hopper with 2 gallons (8 liters) of tap water.
- B. Place the switch in the CLEAN position. The auger will start to rotate.
- C. Allow the water to agitate for approximately 30 seconds.
- D. Open the spigot to drain the water. Remember to place a container under the spigot to catch the water. When the water has drained, place the switch in the OFF (middle) position. Allow the freezing cylinder to drain completely.
- E. Rinse the machine with tap water again.
- F. Wash the hopper with a clean barrel brush dipped in cleaning solution.

3.9 DISASSEMBLY OF MACHINE PARTS

Inspection for worn or broken parts should be made each time the machine is disassembled. All worn or broken parts should be replaced to ensure safety to both the operator and the customer and to maintain good machine performance and a quality product. Frequency of cleaning must comply with the local health regulations.



CAUTION

Hazardous Moving Parts.

Revolving auger shaft can grab and cause injury. Place the switch in the OFF (middle) position before disassembling for cleaning or servicing.



Figure 3-4 Removing O-Ring

To disassemble the machine, refer to the following steps:

- A. Remove the drive cap from the agitator and remove the agitator. Remove the bushing from the bottom of the agitator.
- B. Remove the front door by turning the circular knobs and then pulling the door off the studs.
- C. Remove the o-ring from the groove in the front door.
- D. Remove the auger support bushing.
- E. Remove the spigot body from the front door.
- F. Remove the o-rings (2) from the spigot by first wiping off the lubricant using a clean towel. Then squeeze the o-ring upward with a dry cloth. When a loop is formed, roll the o-ring out of the groove.
- G. Remove the auger assembly from the freezing cylinder and remove the auger blades.
- H. Remove the rear seal and o-ring from the auger. Wipe off any remaining lubricant on the auger shaft and o-ring. Wipe the spline lubricant off the back of the auger shaft.
- I. Remove the drain tray, drip tray and drip tray grid.

3.10 CLEANING AND SANITIZING THE MACHINE PARTS

Place all loose parts in a pan or container and take to the wash sink for cleaning. Local and state health codes dictate the procedure required. Some health codes require a four-sink process (pre-wash, wash, rinse, sanitize, and air-dry), while other codes require a three-sink process (without the pre-wash step). The following procedures are a general guideline only. Consult your local and state health codes for procedures required in your location.

- A. Prepare Stera-Sheen or equivalent cleaner in 2 gallons of 90° to 110°F (32° to 43°C) water following manufacturers instructions.

- B. Prepare sanitizing solution according to manufacturer's instructions to provide a 100 ppm strength solution. Mix the sanitizer in quantities of no less than 2 gallons of 90° to 110°F (32° to 43°C) water. Check the strength of the sanitizing solution. Use a chlorine test strip and color chart to make sure the solution has 100 ppm.
- D. Place all parts in the cleaning solution and clean the parts with the provided brushes. Rinse all parts with clean 90° to 110°F (32° to 43°C) water. Place the parts in the sanitizing solution.
- E. Remove the parts from the sanitizing solution and allow them to air dry.
- F. Wash the hopper and freezing cylinder with the 90° to 110°F (32° to 43°C) cleaning solution and brushes provided.
- G. Clean the rear seal surfaces from the inside of the freezing cylinder with the 90° to 110°F (32° to 43°C) cleaning solution.

3.11 SANITIZE MACHINE

CAUTION
Do not allow sanitizer to remain in contact with stainless steel parts for prolonged periods. Prolonged contact of sanitizer with machine may cause corrosion of stainless steel parts.

- A. Use Stera-Sheen or equivalent sanitizing solution mixed according to manufacturer's instructions to provide 100 parts per million strength solution. Mix sanitizer in quantities of no less than 2 gallons (7.5 liters) of 90° to 110°F (32° to 43°C) water. Any sanitizer must be used only in accordance with the manufacturer's instructions.
- B. With the large brush provided, sanitize the rear of the freezing cylinder by dipping the brush in the sanitizing solution and brushing the rear of the cylinder.

3.12 ROUTINE CLEANING

To remove spilled or dried mix from the machine exterior, wash in the direction of the finish with warm soapy water and wipe dry. Do not use highly abrasive materials as they will mar the finish.

3.13 PREVENTIVE MAINTENANCE

A. DAILY

1. The exterior should be kept clean at all times to preserve the luster of the stainless steel. A mild alkaline cleaner is recommended. Use a soft cloth or sponge to apply the cleaner.

B. WEEKLY

1. Check o-rings and rear seal for excessive wear and replace if necessary.
2. Remove the drip tray and drain tray. Clean the area around the tray and the front of the machine with a soap solution.

C. QUARTERLY

Air Cooled & Hopper Condenser

The condensers are copper tube and aluminum fin type. Condensing is totally dependent upon airflow. A plugged condenser filter, condenser, or restrictions in the louvered panel will restrict airflow. This could increase the hopper temperature, lower the capacity of the system or damage the compressor.

The condensers must be kept clean of dirt and grease. The machine must have 3" (7.6 cm) ventilation on both sides. Make sure the machine is not pulling over 100° F (37° C) air from other equipment in the area.

The condensers and condenser filters require periodic cleaning. To clean, refer to the following procedures.

- A. Disconnect power to the machine
- B. Remove the Phillips head screws from the right side panel, and remove the panel.
- C. To remove a condenser filter, grasp the top and pull off. Visually inspect the filters for dirt. If a filter is dirty, shake or brush excess dirt off the filter and wash it in warm, soapy water. Once it is clean, rinse it thoroughly in warm, clear water and shake dry, taking care not to damage the filter in any way.

Water Cooled

The water-cooled condenser is a tube and shell type. The condenser needs a cool, clean supply of water to properly cool the machine. Inlet and discharge lines must be 3/8" I.D. minimum. Make sure the machine is receiving an unrestricted supply of cold, clean water.

E. SEMI-ANNUALLY

1. Disconnect the machine from the power source.
2. Use a Burroughs Belt Tension Gauge to set the tension for the drive belt. Set the belt tension to 45-55 lbs.
3. Lubricate the condenser fan motor with S.A.E. 20 weight oil. Three to six drops are required.

3.14 EXTENDED STORAGE

Refer to the following steps for storage of the machine over any long period of shutdown time:

- A. Place the CLEAN-OFF-ON switch in the OFF (middle) position.
- B. Disconnect (unplug) from the electrical supply source.
- C. Clean all parts that come in contact with mix thoroughly with a warm water cleaning solution. Rinse in clean water and dry parts. Do not sanitize.

NOTE

Do not let the cleaning solution stand in the hopper or in the freezing cylinder during the shutdown period.

- D. In a water cooled machine, disconnect the water lines and drain water. With a flathead screwdriver, hold the water valve open and use compressed air to clear the lines of any remaining water.

SECTION 4 TROUBLESHOOTING

4.1 LIGHT INDICATORS

The machine has two lights that will alert the user if a problem occurs: an ADD MIX light and a Diagnostic Light.

The ADD MIX light will flash to alert the operator to a low mix condition. It does so by monitoring the mix level in the hopper. When the ADD MIX light is flashing, refill hopper immediately.

The Diagnostic Light will flash if an error occurs. Refer to the chart below for details.

Indication	On	One Blink	Two Blinks	Three Blinks
Conditions	Standby Mode	Torque is not met after 22 minutes	Drive current is not sensed	Machine left in clean mode for over 20 minutes
Self Correction	N/A	N/A	The machine attempts to sense drive current with a 3 second pre-stir. If current is sensed, the machine will return to normal operation. If current is not sensed, the machine will wait 7 minutes and try to sense current with another 3 second pre-stir. After the third attempt, the compressor will run on timers.	N/A
Operation	Every 10 minutes the machine will run for 30 seconds.	Timers or until the consistency sensor is satisfied.	Timers	Off
Corrective Action	Standby Mode ends when the spigot is opened or when the CLEAN-OFF-ON switch is moved to OFF position then to the ON position	Check the condenser (Section 3.13). Make sure the auger is installed correctly (Section 3.11). Contact Service Technician	Contact Service Technician	Turn CLEAN-OFF-ON switch to OFF (middle) position then turn the switch to ON.

4.2 TROUBLESHOOTING

PROBLEM	POSSIBLE CAUSE	REMEDY
Machine does not run.	<ol style="list-style-type: none"> 1 Power to machine is off. 2 Blown fuse or tripped circuit. 3 Freeze-up (auger will not turn). 4 Front door not in place. 	<ol style="list-style-type: none"> 1 Supply power to machine. 2 Replace or reset. 3 Turn Clean/Off/On switch Off for 15 minutes, then restart. 4 Assemble front door in place.
Product is too firm.	<ol style="list-style-type: none"> 1 Temperature setting is too cold. 	<ol style="list-style-type: none"> 1 Adjust the Temperature Adjustment Screw (Section 3.2)

4.2 TROUBLESHOOTING - CONTINUED

PROBLEM	POSSIBLE CAUSE	REMEDY
Product is too thin.	<ol style="list-style-type: none"> 1 Temperature setting too warm. 2 No vent space for free flow of cooling air. 3 Condenser is dirty. 4 Auger is assembled incorrectly. 5 Refrigeration problem. 	<ol style="list-style-type: none"> 1 Adjust the Temperature Adjustment Screw (Section 3.2) 2 A minimum of 3" of air space at the sides. 3 Clean the condenser. (See Section 3.13) 4 Remove mix, clean, reassemble, sanitize and freeze down. 5 Check system. (Call a service technician)
Product does not dispense or it is a very slow draw rate.	<ol style="list-style-type: none"> 1 No mix in hopper. 2 Auger is not turning 3 Mix inlet regulator is obstructed or clogged. 4 Front door has frozen product or is clogged. 	<ol style="list-style-type: none"> 1 Add mix to the hopper 2 Check system. (Call a service technician) 3 Clean the mix inlet regulator and make sure the mix is fully thawed. 4 Turn Clean/Off/On switch to Clean for 5 minutes, then restart.
Drive belt slipping or squealing.	<ol style="list-style-type: none"> 1 Not tensioned properly. 2 Worn drive belt. 3 Freeze-up (Auger will not turn). 	<ol style="list-style-type: none"> 1 Adjust belt tension 2 Replace drive belt. 3 Turn Clean/Off/On switch Off for 15 minutes, then restart.
Rear auger seal leaks.	<ol style="list-style-type: none"> 1 Outside surface of rear auger seal is lubricated. 2 Rear seal missing or damaged. 3 Seal o-ring missing or damaged. 4 Worn or scratched auger shaft. 	<ol style="list-style-type: none"> 1 Clean lubricant from outside of rear seal and rear of the freezing cylinder. Lubricate the rear seal o-ring and reinstall the auger (See Section 3.11) 2 Check or replace. 3 Check. or replace. 4 Replace auger shaft.
Front door leaks.	<ol style="list-style-type: none"> 1 Front door knobs are loose. 2 Spigot o-rings are not lubricated. 3 Chipped or worn spigot o-rings. 4 Inner spigot hole in front door nicked or scratched. 	<ol style="list-style-type: none"> 1 Tighten knobs in a crisscross pattern. 2 Lubricate the spigot o-rings 3 Replace o-rings. 4 Replace front door.

SECTION 5 REPLACEMENT PARTS

5.1 BRUSHES, DECALS, AND LUBRICATION

Part	Description	Quantity
C-1000-26C	Decal - Made In USA	1
208135	Brush - 4" X 8" X 16" (Barrel)	1
208380	Brush - 1/4" X 3" X 14"	1
208401	Brush - 1" X 3" X 10"	1
208410	Brush - 1-1/2" X 4" X 12"	1
324065	Decal - Water Inlet	1
324105	Decal - Caution Electrical Shock	6
324106	Decal - Caution Electrical Wiring Materials	1
324107	Decal - Caution Hazardous Moving Parts	3
324141	Decal - Caution Rotating Blades	1
324200	Decal - High Pressure Cut-Out	1
324208	Decal - Attention Refrigerant Leak Check	2
324242	Decal - Temperature Adjustment	1
324393	Decal - Stoelting Swirl Logo	1
324509	Decal - Cleaning Instructions	1
324566	Decal - Wired According To	1
324584	Decal - Adequate Ventilation 3"	2
324803	Decal - Domed Stoelting Logo (Large) (Header Panel)	1
324804	Decal - Domed Stoelting Swirl (Header Panel)	1
324865	Decal - Standby Light	1
324927	Decal - Motor Compressor Thermally Protected	1
508048	Lubricant - Spline (2 oz Squeeze Tube)	1
508135	Petrol Gel - 4 oz Tube	1

5.2 AUGER SHAFT AND FACEPLATE PARTS

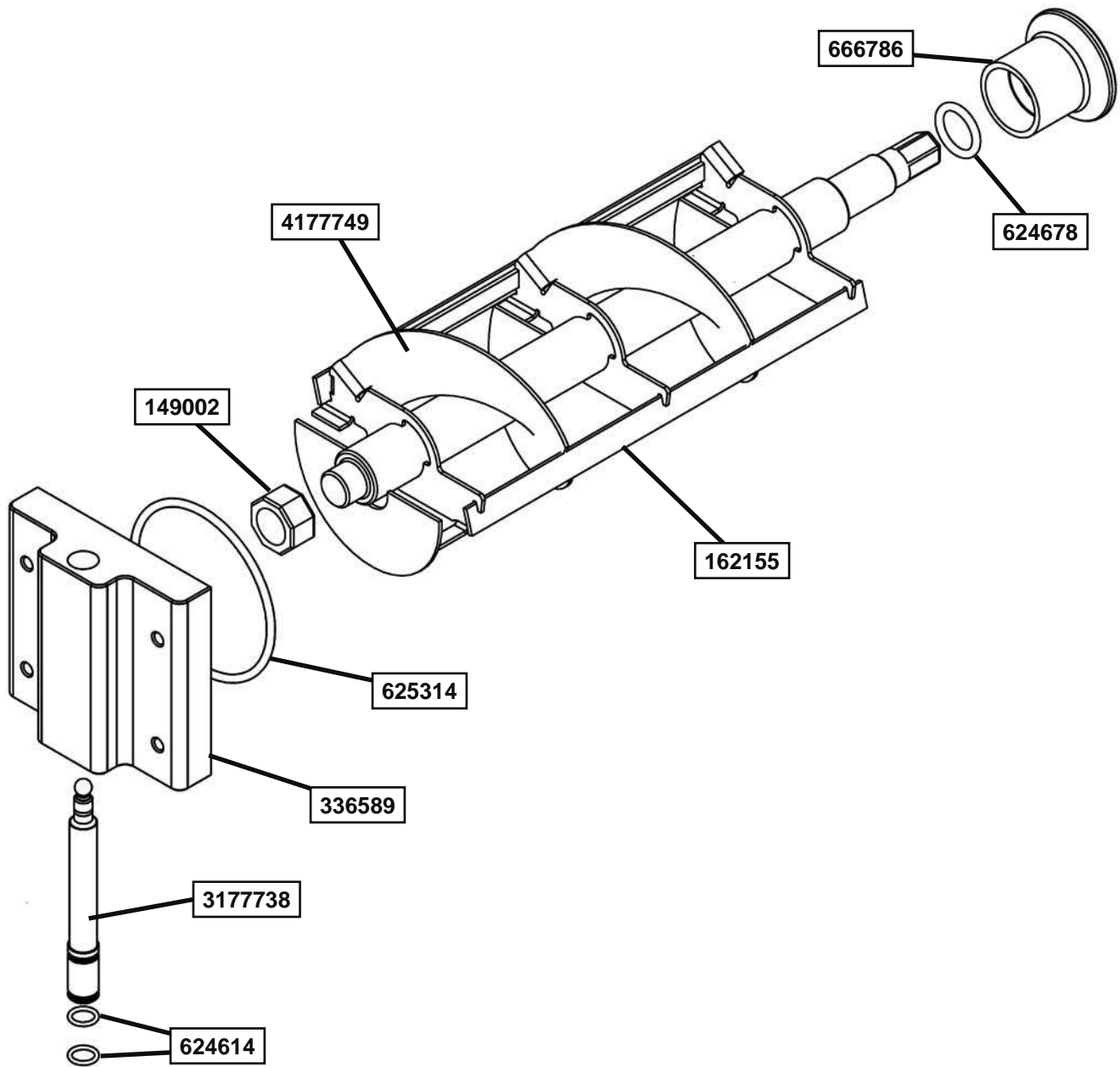

Part	Description	Quantity
149002	Bushing - Front Auger Support	1
162155	Blade - Scraper	2
336589	Door - Front	1
482019	Knob - Front Door (Black)	4
624614-5	O-Ring - Spigot (5 Pack)	2
624678-5	O-Ring - Rear Seal - Black (5 Pack)	1
625314	O-Ring - Front Door - Black	1
666786	Seal - Rear Auger - Black	1
3177738	Spigot Body	1
4177749	Auger Shaft	1

5.3 HOPPER PARTS

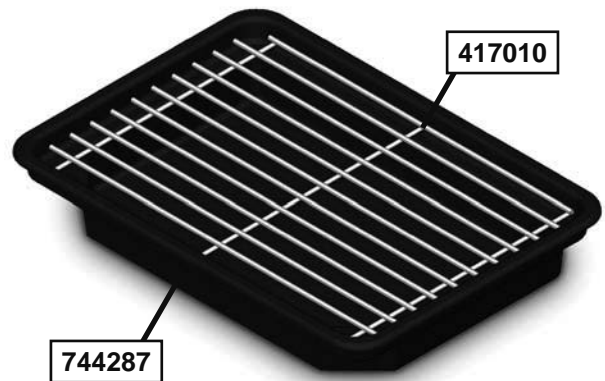
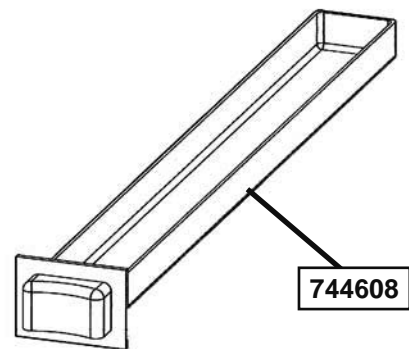
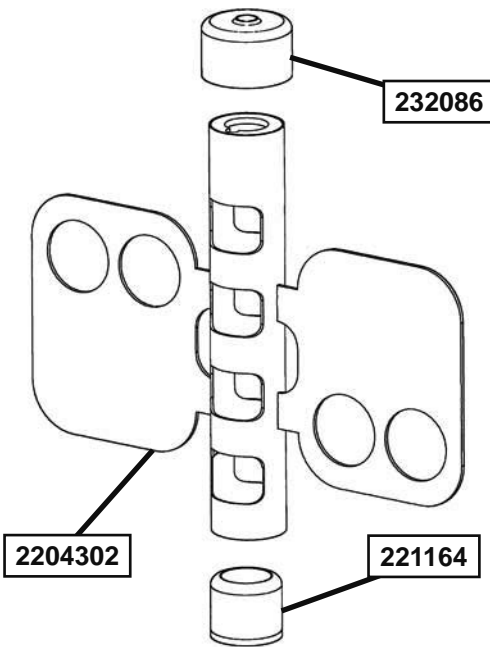
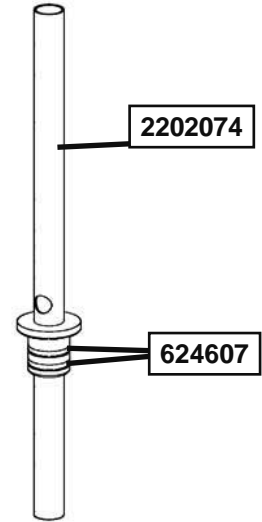
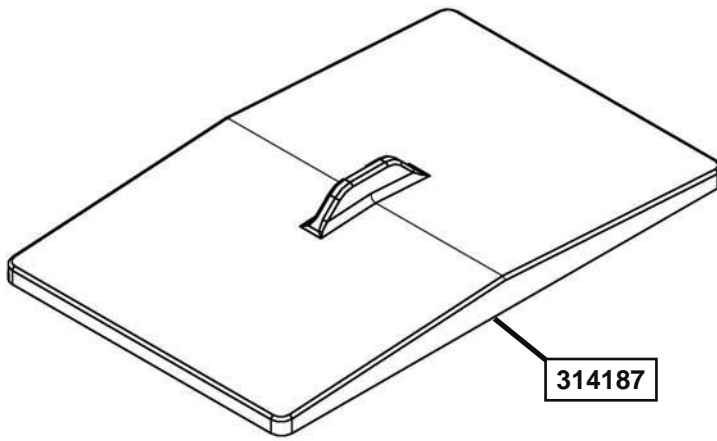

Part	Description	Quantity
221164	Bushing - Agitator Bottom Center Post	1
232086	Cap - Drive	1
314187	Cover - Hopper	1
417010	Grid - Drip Tray	1
624607	O-Ring - Mix Inlet	2
744287	Tray - Drip	1
744608	Tray - Drain	1
2202074	Mix Inlet Assembly	1
2204302	Agitator - Hopper	1



**DOMESTIC WARRANTY
(Including Mexico)
SOFT SERVE / SHAKE EQUIPMENT**

1. **Scope:**
PW Stoelting, L.L.C. (“Stoelting”) warrants to the first user (the “Buyer”) that the freezing cylinders, hoppers, compressors, drive motors, speed reducers, and augers of Stoelting soft serve / shake equipment will be free from defects in materials and workmanship under normal use and proper maintenance appearing within five (5) years, and that all other components of such equipment manufactured by Stoelting will be free from defects in material and workmanship under normal use and proper maintenance appearing within twelve (12) months after the date that such equipment is originally installed.

2. **Disclaimer of Other Warranties:**

THIS WARRANTY IS EXCLUSIVE; AND STOELTING HEREBY DISCLAIMS ANY IMPLIED WARRANTY OF MERCHANTABILITY OR FITNESS FOR PARTICULAR PURPOSE.

3. **Remedies:**
Stoelting’s sole obligations, and Buyer’s sole remedies, for any breach of this warranty shall be the repair or (at Stoelting’s option) replacement of the affected component at Stoelting’s plant in Kiel, Wisconsin, or (again, at Stoelting’s option) refund of the purchase price of the affected equipment, and, during the first twelve (12) months of the warranty period, deinstallation/reinstallation of the affected component from/into the equipment. Those obligations/remedies are subject to the conditions that Buyer (a) signs and returns to Stoelting, upon installation, the Start-Up and Training Checklist for the affected equipment, (b) gives Stoelting prompt written notice of any claimed breach of warranty within the applicable warranty period, and (c) delivers the affected equipment to Stoelting or its designated service location, in its original packaging/crating, also within that period. Buyer shall bear the cost and risk of shipping to and from Stoelting’s plant or designated service location.

4. **Exclusions and Limitations:**
This warranty does not extend to parts, sometimes called “wear parts”, which are generally expected to deteriorate and to require replacement as equipment is used, including as examples but not intended to be limited to o-rings, auger flights, auger seals, auger support bushings, and drive belts. All such parts are sold

AS IS.

Further, Stoelting shall not be responsible to provide any remedy under this warranty with respect to any component that fails by reason of negligence, abnormal use, misuse or abuse, use with parts or equipment not manufactured or supplied by Stoelting, or damage in transit.

THE REMEDIES SET FORTH IN THIS WARRANTY SHALL BE THE SOLE LIABILITY STOELTING AND THE EXCLUSIVE REMEDY OF BUYER WITH RESPECT TO EQUIPMENT SUPPLIED BY STOELTING; AND IN NO EVENT SHALL STOELTING BE LIABLE FOR ANY INCIDENTAL OR CONSEQUENTIAL DAMAGES, WHETHER FOR BREACH OF WARRANTY OR OTHER CONTRACT BREACH, NEGLIGENCE OR OTHER TORT, OR ON ANY STRICT LIABILITY THEORY.