



Model SU444
OPERATORS MANUAL

Manual No. 513639

Rev.3

This manual provides basic information about the machine. Instructions and suggestions are given covering its operation and care.

The illustrations and specifications are not binding in detail. We reserve the right to make changes to the machine without notice, and without incurring any obligation to modify or provide new parts for machines built prior to date of change.

DO NOT ATTEMPT to operate the machine until instructions and safety precautions in this manual are read completely and are thoroughly understood. If problems develop or questions arise in connection with installation, operation, or servicing of the machine, contact Stoelting.



stoeltingfoodservice.com

Stoelting Foodservice Equipment
502 Highway 67
Kiel, WI 53042-1600
U.S.A.

Main Tel: 800.558.5807
Fax: 920.894.7029

Customer Service: 888.429.5920
Fax: 800.545.0662
Email: foodservice@stoelting.com

© 2014 PW Stoelting, LLC

A Few Words About Safety

Safety Information

Read and understand the entire manual before operating or maintaining Stoelting equipment.

This manual provides the operator with information for the safe operation and maintenance of Stoelting equipment. As with any machine, there are hazards associated with their operation. For this reason safety is emphasized throughout the manual. To highlight specific safety information, the following safety definitions are provided to assist the reader.

The purpose of safety symbols is to attract your attention to possible dangers. The safety symbols, and their explanations, deserve your careful attention and understanding. The safety warnings do not by themselves eliminate any danger. The instructions or warnings they give are not substitutes for proper accident prevention measures.

If you need to replace a part, use genuine Stoelting parts with the correct part number or an equivalent part. We strongly recommend that you do not use replacement parts of inferior quality.



Safety Alert Symbol:

This symbol Indicates danger, warning or caution. Attention is required in order to avoid serious personal injury. The message that follows the symbol contains important information about safety.

Signal Word:

Signal words are distinctive words used throughout this manual that alert the reader to the existence and relative degree of a hazard.



The signal word “WARNING” indicates a potentially hazardous situation, which, if not avoided, may result in death or serious injury and equipment/property damage.



The signal word “CAUTION” indicates a potentially hazardous situation, which, if not avoided, may result in minor or moderate injury and equipment/property damage.

CAUTION

The signal word “CAUTION” not preceded by the safety alert symbol indicates a potentially hazardous situation, which, if not avoided, may result in equipment/property damage.

NOTE (or NOTICE)

The signal word “NOTICE” indicates information or procedures that relate directly or indirectly to the safety of personnel or equipment/property.

TABLE OF CONTENTS

Section	Description	Page
1	Description and Specifications	
1.1	Description.....	1
1.2	Specifications	2
2	Installation Instructions	
2.1	Safety Precautions	3
2.2	Shipment and Transit.....	3
2.3	Machine Installation.....	3
2.4	Installing Permanent Wiring.....	3
2.5	Check Check Compressor for Proper Power	4
2.6	Check Blender Rotation.....	4
2.7	Mix Pump.....	4
A.	Mix Pump Hose Installation.....	4
B.	Mix Pickup Hose Installation	5
C.	Mix Low Level Indicator Adjustment.....	6
3	Initial Set-Up and Operation	
3.1	Operator's Safety Precautions.....	7
3.2	Operating Controls and Indicators.....	7
3.3	Important Information Regarding Cleaning and Sanitizing	9
3.4	Disassembly of Left Side	10
A.	Remove Front Door and Auger	11
3.5	Disassembly of Right Side.....	11
A.	Remove Blender (SU444 Only).....	11
B.	Remove Front Door and Auger	11
3.6	Cleaning Disassembled Parts	12
3.7	Sanitizing Parts.....	12
3.8	Cleaning the Machine.....	12
3.9	Assembling the Left Side.....	12
3.10	Assembling the Right Side	13
3.11	Sanitizing	14
3.12	Initial Freeze Down and Operation	15
A.	Adding Mix	15
B.	Preparing the IntelliTec Control	15
C.	Initial Freeze Down	15
D.	Adjusting the IntelliTec Control.....	15
E.	Serving Product.....	16
3.13	Normal Freeze Down and Operation.....	16
3.14	Mix Information	17
3.15	Operation of Mix Pump.....	17
3.16	Mix Pump Cleaning	17
3.17	Disassembly and Inspection of Removable Parts	18

Section	Description	Page
4	Maintenance and Adjustments	
4.1	Machine Adjustment	19
4.2	Product Temperature Adjustment (Left Side).....	19
4.3	Product Consistency Adjustment (Right Side).....	19
4.4	Locking the Control Panel (Right Side)	19
4.5	Obtaining Readings and Modifying Settings (Service Personnel Only) (Right Side).....	19
4.6	Readings (Service Personnel Only) (Right Side)	20
4.7	Adjustments (Service Personnel Only) (Right Side).....	21
4.8	Other Settings (Service Personnel Only) (Right Side).....	21
4.9	Overrun Adjustment.....	22
4.10	Mix Pump Hose Reposition	23
4.11	Mix Pump Hose Replacement.....	24
4.12	Cab Temperature Adjustment	24
4.13	Drive Belt Tension Adjustment.....	25
4.14	Condenser Cleaning (Air-Cooled Machines)	25
4.15	Preventative Maintenance	25
4.16	Extended Storage.....	26
5	Troubleshooting	
5.1	Error Codes (Right Side)	27
5.2	Troubleshooting - Error Codes (Right Side)	27
5.3	Troubleshooting - Machine	29
5.4	Troubleshooting - Mix Pump.....	31
6	Replacement Parts	
6.1	Brushes, Decals and Lubrication.....	33
6.2	Left Side Auger Shaft and Front Door Parts	34
6.3	Right Side Auger Shaft and Front Door Parts.....	35
6.4	Blender Parts and Drip Tray	36
6.5	Cab Tubing	37

SECTION 1 DESCRIPTION AND SPECIFICATIONS

1.1 DESCRIPTION

The Stoelting SU444 and U444A floor model machines are pressure fed. They are equipped with fully automatic controls to provide a uniform product. The SU444 and U444A are designed to dispense soft serve product from the left side and shake product from the right side. The SU444 has a blender attached to the front door of the shake side.

This manual is designed to assist qualified service personnel and operators with installation, operation and maintenance of the SU444 and U444A.



Figure 1-1 Model SU444 Machine

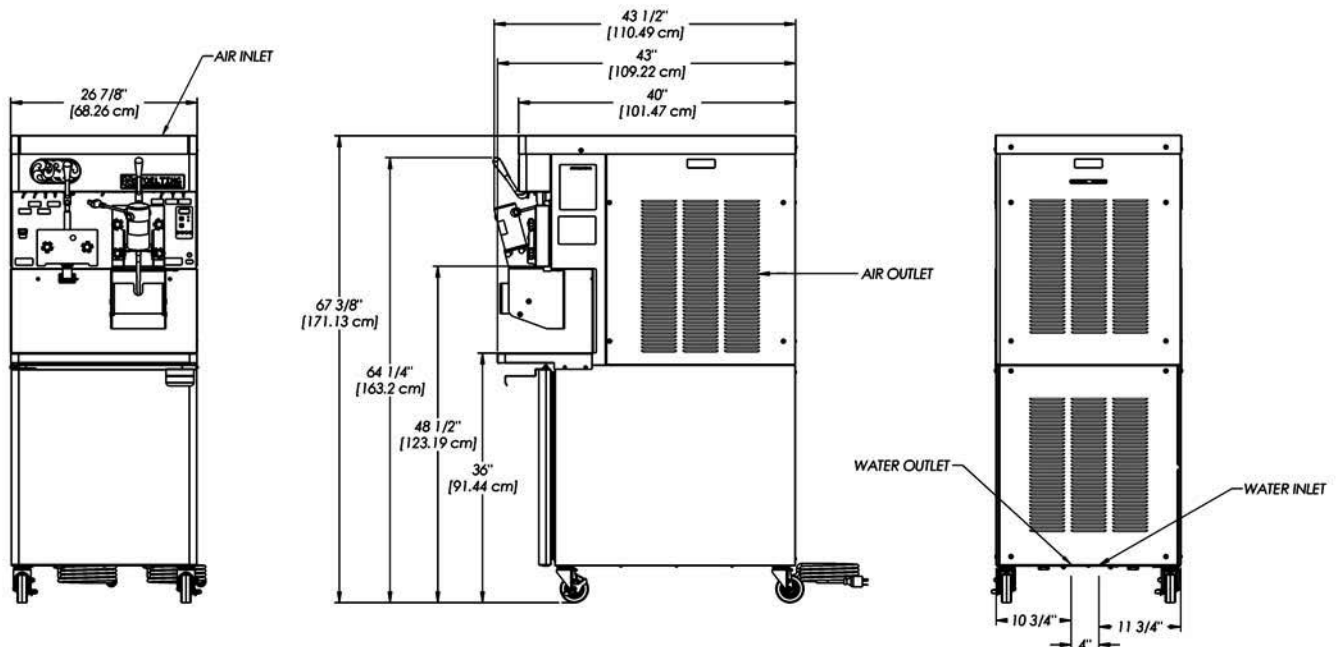

Figure 1-2 Dimensions

1.2 SPECIFICATIONS

	SU444 Water Cooled				SU444 Air Cooled			
Dimensions	Machine		with crate		Machine		with crate	
width	26-7/8" (68,3 cm)		34" (86,4 cm)		26-7/8" (68,3 cm)		34" (86,4 cm)	
height	67-3/8" (171,1 cm)		78" (198,1 cm)		67-3/8" (171,1 cm)		78" (198,1 cm)	
depth	40" (101,6 cm)		48" (121,9 cm)		40" (101,6 cm)		48" (121,9 cm)	
Weight	760 lbs (344,7 kg)		908 lbs (411,8 kg)		760 lbs (344,7 kg)		908 lbs (411,8 kg)	
Electrical	1 PH		3 PH		1 PH		3 PH	
	left	right	left	right	left	right	left	right
minimum circuit ampacity	31A	26A	19A	18A	32A	26A	20A	18A
maximum overcurrent protection device	50A	40A	30A	25A	50A	40A	30A	25A
Compressor	Soft Serve - 19,000 Btu/hr Scroll™ Compressor (R-404A) Shake - 15,000 Btu/hr Scroll™ Compressor (R-404A) Cabinet - 1,300 Btu/hr Compressor (R-134a)							
Drive Motor	Soft Serve - 2 hp, Shake - 3/4 hp							
Cooling	Water cooled units require 1/2" N.P.T. water and drain fittings. Maximum water pressure of 130 psi. Minimum water flow rate of 3 GPM. Ideal EWT of 50°-70°F. The machine requires 6" (15,2 cm) air space on all sides for the cabinet refrigeration system.				Air cooled units require 6" (15,2 cm) air space on both sides and back.			
Hopper Volume	Two - 8 gallon (30,28 liters)							
Freezing Cylinder Volume	Soft Serve - 1.33 gallon (5,4 liters) Shake - 2.1 gallon (7,95 liters)							

SECTION 2 INSTALLATION INSTRUCTIONS

2.1 SAFETY PRECAUTIONS

Do not attempt to operate the machine until the safety precautions and operating instructions in this manual are read completely and are thoroughly understood.

Take notice of all warning labels on the machine. The labels have been put there to help maintain a safe working environment. The labels have been designed to withstand washing and cleaning. All labels must remain legible for the life of the machine. Labels should be checked periodically to be sure they can be recognized as warning labels.

If danger, warning or caution labels are needed, indicate the part number, type of label, location of label, and quantity required along with your address and mail to:

STOELTING
ATTENTION: Customer Service
502 Hwy. 67
Kiel, Wisconsin 53042

2.2 SHIPMENT AND TRANSIT

The machine has been assembled, operated and inspected at the factory. Upon arrival at the final destination, the entire machine must be checked for any damage which may have occurred during transit.

With the method of packaging used, the machine should arrive in excellent condition. **THE CARRIER IS RESPONSIBLE FOR ALL DAMAGE IN TRANSIT, WHETHER VISIBLE OR CONCEALED.** Do not pay the freight bill until the machine has been checked for damage. Have the carrier note any visible damage on the freight bill. If concealed damage and/or shortage is found later, advise the carrier within 10 days and request inspection. The customer must place a claim for damages and/or shortages in shipment with the carrier. Stoelting, Inc. cannot make any claims against the carrier.

2.3 MACHINE INSTALLATION



WARNING

Installation must be completed by a qualified electrician/refrigeration specialist.

Incorrect installation may cause personal injury, severe damage to the machine and will void factory warranty.

Installation of the machine involves moving the machine close to its permanent location, removing all crating, setting in place, assembling parts, and cleaning.

- A. Uncrate the machine.

- B. Install the four casters. Turn the threaded end into the machine until no threads are showing. To level, turn out casters no more than 1/4" maximum, then tighten all jam nuts.
- C. The machine must be placed in a solid level position.

NOTE

Accurate leveling is necessary for correct drainage of freezing cylinder and to insure correct overrun.

- D. Machines with air cooled condensers require a minimum of 6" (15,2cm) space on all sides and back for proper circulation.

NOTE

In order for the condenser fan motor to work the left side needs to be connected to a power source.

- E. Machines that have a water cooled condenser require 1/2" NPT supply and drain fittings.

2.4 INSTALLING WIRING

- A. Refer to the nameplate on the side panel of the machine for specific electrical requirements. Make sure the power source in the building matches the nameplate requirements. Bring the wires into the junction boxes through the access holes in the bottom rear of the freezer.

NOTE

Three phase freezers in areas of unbalanced electrical loads require special attention when connecting input electrical power. The unbalanced leg of power (called wild or high) must be connected to L2 in the junction box.

- B. Remove the back panel and the junction box cover located at the bottom of the machine.
- C. Install permanent wiring according to local code.
- D. If the line voltage is less than 215V, the fan motor needs to be rewired. Refer to the wiring diagram for details.

NOTE

Low incoming voltage affects the fan motor speed and could cause high head pressure errors from the reduced air flow. Rewiring the fan motor prevents the fan speed from decreasing to an unsuitable rate.

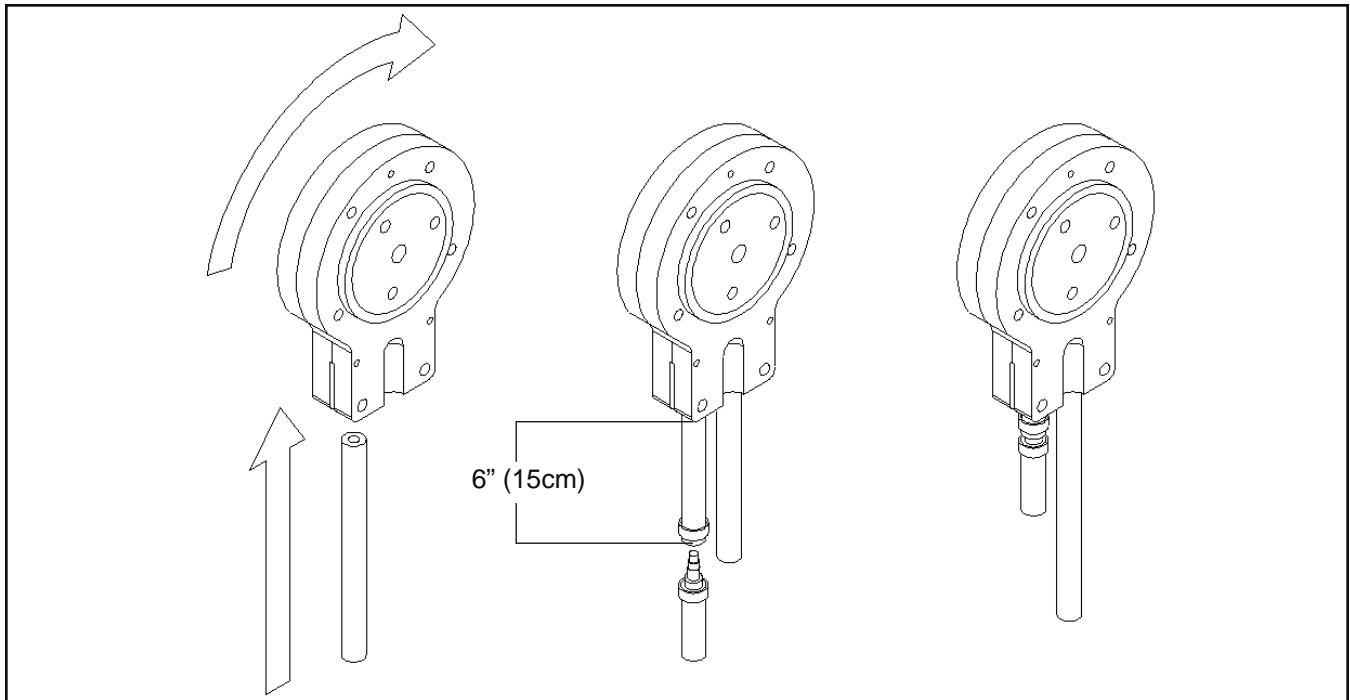

Figure 2-2 Mix Hose Installation

2.5 CHECK COMPRESSOR FOR PROPER POWER (3 PHASE ONLY)

After connecting the electrical, check that the compressor is operating in the proper direction.

- A. Start a freezing cycle.
On the right side, place the Main Freezer Power switch and Freezing Cylinder OFF/ON switch to the ON position. Press the PUSH TO FREEZE button.
On the left side, place the Clean/Off/Serve and the Standby/Serve switches in the Serve position.
- B. The suction line will be cold to the touch within 1 minute.
- C. If it is not, disconnect power to the machine and reverse L1 and L3 lines in the junction box.
- D. After reversing the electrical lines, recheck the suction line.

2.6 CHECK BLENDER ROTATION

After connecting the electrical, check the blender on the right side for proper rotation.

- A. Place the Blender Power Off/On switch to the ON position.
- B. With the clear swing shield in place, move the spigot handle to the right.

WARNING

Hazardous Moving Parts

Blender shaft and agitator can grab and cause injury. Do not operate blender without protective shield or swing splash shield.

- C. The blender should rotate clockwise looking from the top of the blender.
- D. If the rotation is counterclockwise, refer to the wiring diagram located behind the header panel and check the diode direction. Reverse the diode polarity if needed.

2.7 MIX PUMP

A. MIX PUMP HOSE INSTALLATION

Follow the steps below to install the mix pump hose in the cabinet part of the machine.

1. Turn the mix pump on. The switch is located on the header panel.
2. Feed one end of the mix pump hose into the entering or pickup hose side (left) of black cover (Fig 2-2).

NOTE

Feed the tube into the clamp so the natural curve of the tube is towards the outside of the black cover. This prevents the hose from looping around the black cover twice.

3. Gently push the hose into the black cover until it begins to feed.

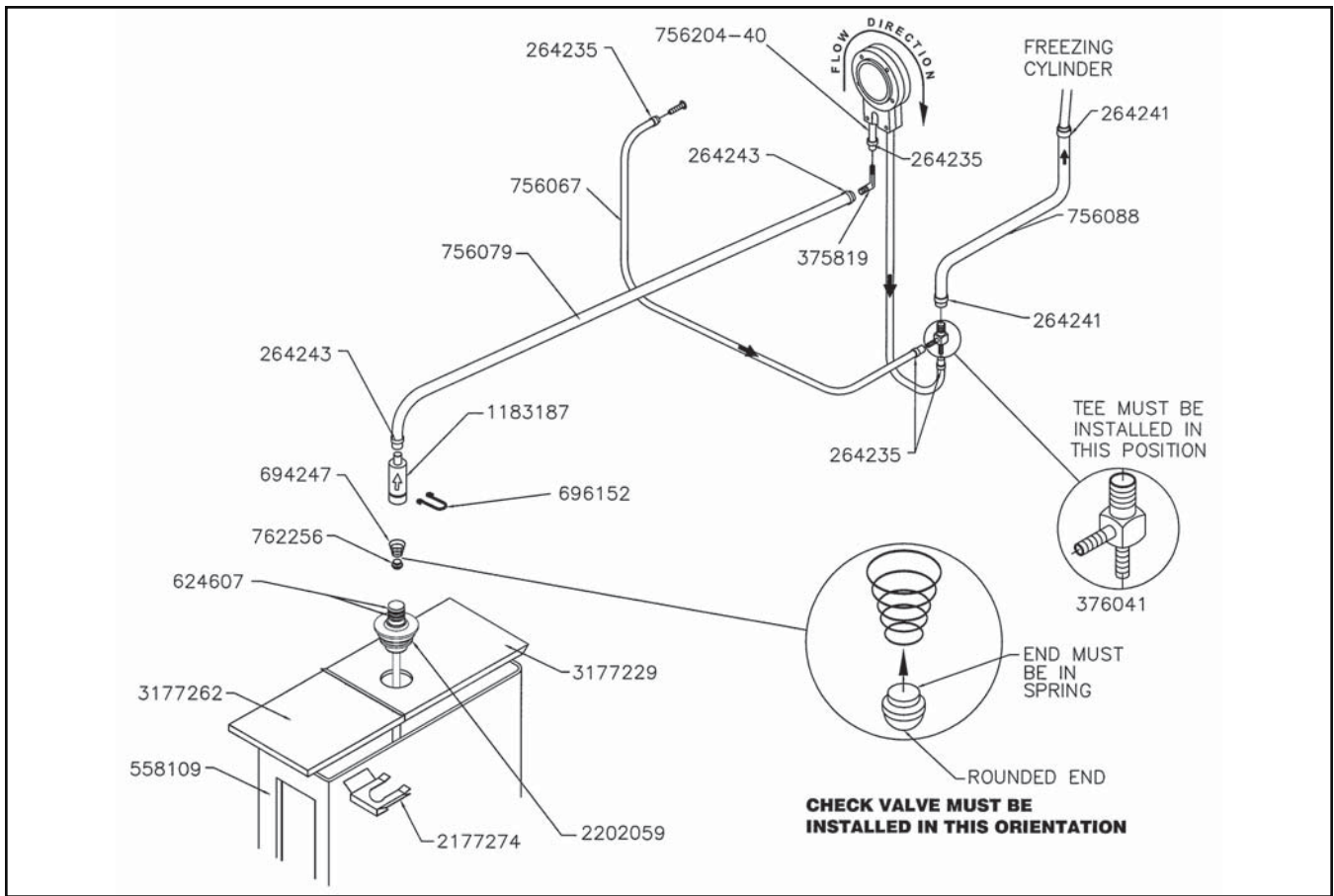

Figure 2-3 Mix Pump Connections for Standard Mix Container

4. Allow the hose to feed itself through the pump until about 6" (15cm) remains on the entering side.
5. Turn the pump off.
6. Connect the mix pump hose to the elbow fitting (located on the left side of the mix line manifold) using a small hose clamp. Be careful not to twist the mix hose.
7. Turn the pump on.
8. Allow the remaining 6" (15cm) of tubing to feed through pump until the hose adapter prevents further feeding.
9. Turn the pump off.

CAUTION
<p>Risk of Product Damage</p> <p>Air/Mix Tee must remain below the black cover clamp. If the Tee is above the pump, mix may drain into the air compressor resulting in pump damage.</p>

10. Connect the free end of the mix pump hose to the 3-way Tee (Fig. 2-3). When all connections are complete, the 3-way Tee must be lower than the black pump housing.

B. MIX PICKUP HOSE INSTALLATION

The machine may be connected to the standard mix container or up to three prepacked mix bags. Follow the instructions below that match your configuration.

Standard Connection:

1. Place the mix pickup assembly through the hole in the cover and install the retaining clip.
2. Connect a 24" (61cm) length of 3/8" (9,5mm) ID plastic food grade tubing to the mix pickup assembly. Secure with a hose clamp.
3. Connect the elbow fitting to the free end of the tubing. Connect the opposite end of the elbow to 1/4" ID tan tubing on the left side of the pump head. Secure with hose clamps (Fig. 2-3).

When Using Bag Connection System (BCS) with Three Bags (optional kit):

The position of the three bags in the mix container is important. The bag that is connected nearest the outlet of the manifold will drain last and should be placed at the back of the mix container. The mix low level indicator relies on proper bag placement.

1. Connect 3/8" (9,5mm) ID plastic food grade tubing to a bag adapter. Secure with hose clamps.

2. Slide the hose clip over free end of 3/8" (9,5mm) ID plastic food grade tubing. Attach the free end of the tubing to a manifold adapter. Secure with a large hose clamp or equivalent.
3. Push the manifold adapter with spring and valve into the left port (nearest the manifold outlet) of the mix inlet manifold and secure with a retaining clip.
4. Repeat steps 1 to 3 for the middle port and for the right port of the mix inlet manifold.
5. Place three mix bags into the mix container.
6. Connect the bag adapter attached to the left side of the manifold (closest to the mix outlet) to the mix bag in the back of the mix container.
7. Connect the bag adapter attached to the middle of the manifold to the mix bag in the middle of the mix container.
8. Connect the bag adapter attached to the right side of the manifold (farthest from the mix outlet) to the mix bag in the front of the mix container.

6. Place the mix bag(s) into the mix container.
7. Connect the bag adapter attached to the left side of the manifold (closest to the mix outlet) to the mix bag in the back of the mix container.

C. MIX LOW LEVEL INDICATOR ADJUSTMENT

The sensitivity of the "Mix Low" indication can be adjusted to operator preference. If more advanced notice of low mix is required, loosen the black adjustment knobs located on the sensor brackets at the back of the machine cabinet and slide the bracket upwards. If the "Mix Low" message (right side) or flashing light (left side) appears while there is still sufficient mix in the container, slide the bracket downward. Be sure to tighten the adjustment knobs after properly positioning the sensor.

When Using Bag Connection System (BCS) with One or Two Bags (optional kit):

When connecting one or two bags, the manifold adapters must be installed closest to the manifold outlet and the manifold plug(s) must be placed farthest from the manifold outlet.

1. Connect 3/8" (9,5mm) ID plastic food grade tubing to a bag adapter. Secure with hose clamps.
2. Slide the hose clip over the free end of the tubing. Attach the free end of the tubing to a manifold adapter. Secure with a large hose clamp.
3. Push the manifold adapter with spring and valve into the left port (nearest the manifold outlet) of the mix inlet manifold and secure with retaining clip. (See Figure 2-4).
4. If using two mix bags, repeat steps 1 to 3 for the middle port.
5. Install a manifold plug into each empty inlet and secure with a retaining clip.

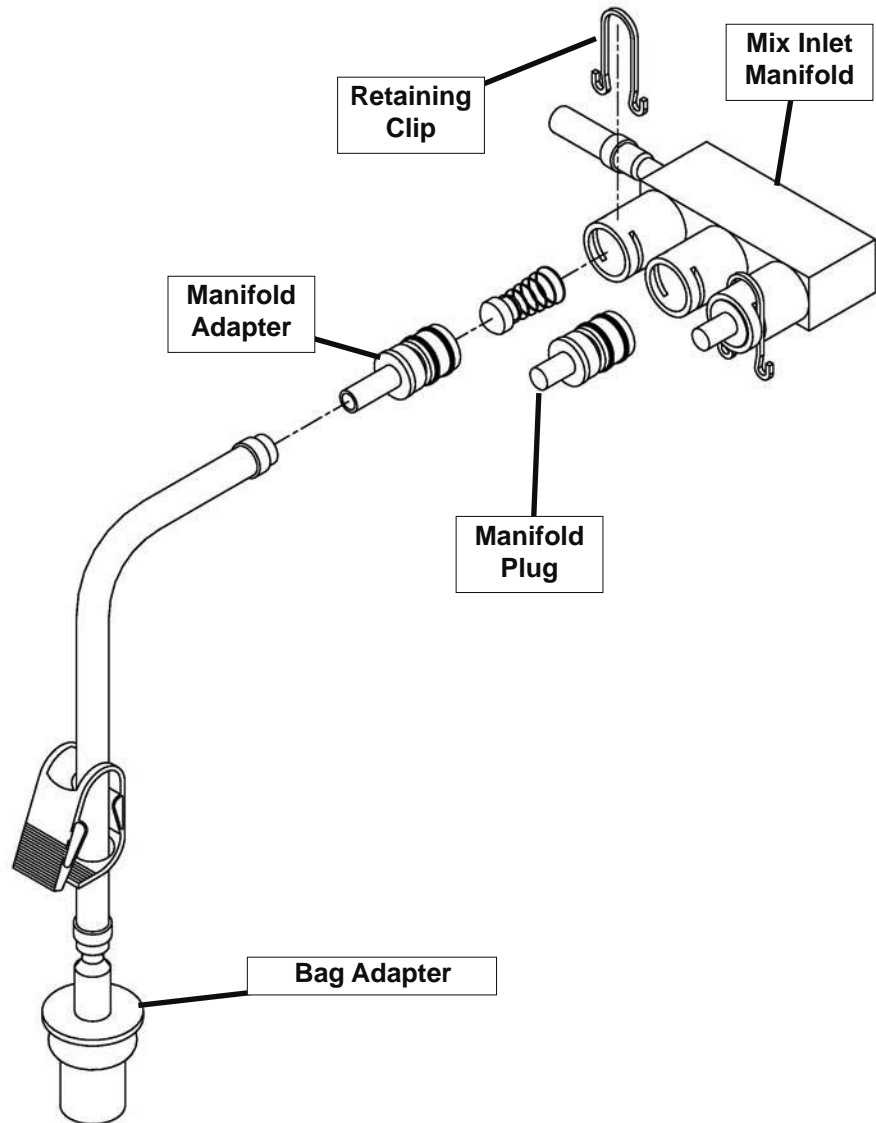

Figure 2-4 Bag Connection System (Optional)

SECTION 3 INITIAL SET-UP AND OPERATION

3.1 OPERATOR'S SAFETY PRECAUTIONS

SAFE OPERATION IS NO ACCIDENT; observe these rules:

- A. Know the machine. Read and understand the Operating Instructions.
- B. Notice all warning labels on the machine.
- C. Wear proper clothing. Avoid loose fitting garments, and remove watches, rings or jewelry that could cause a serious accident.
- D. Maintain a clean work area. Avoid accidents by cleaning up the area and keeping it clean.
- E. Stay alert at all times. Know which switch, push button or control you are about to use and what effect it is going to have.
- F. Disconnect power for maintenance. Never attempt to repair or perform maintenance on the machine until the main electrical power has been disconnected.
- G. Do not operate under unsafe operating conditions. Never operate the machine if unusual or excessive noise or vibration occurs.

3.2 OPERATING CONTROLS AND INDICATORS

Before operating the machine, it is required that the operator know the function of each operating control. Refer to Figure 3-1 for the location of the operating controls on the machine. For the information regarding error codes displayed on the control panel, refer to the troubleshooting section of this manual.

A. PUMP SWITCH (BOTH SIDES)

The pump motor switch is the toggle switch located under the header panel. When the switch is placed in the OFF position, the pump will not run. When the switch is placed in the ON position, the pump will run until the preset pressure is reached. It then cycles on and off as product is drawn to maintain that pressure.

B. SPIGOT SWITCH (BOTH SIDES)

The spigot switch is mounted to the spigot cam assembly behind the header panel. When the spigot is opened to dispense product, the spigot switch opens and the "Serve Mode" begins.

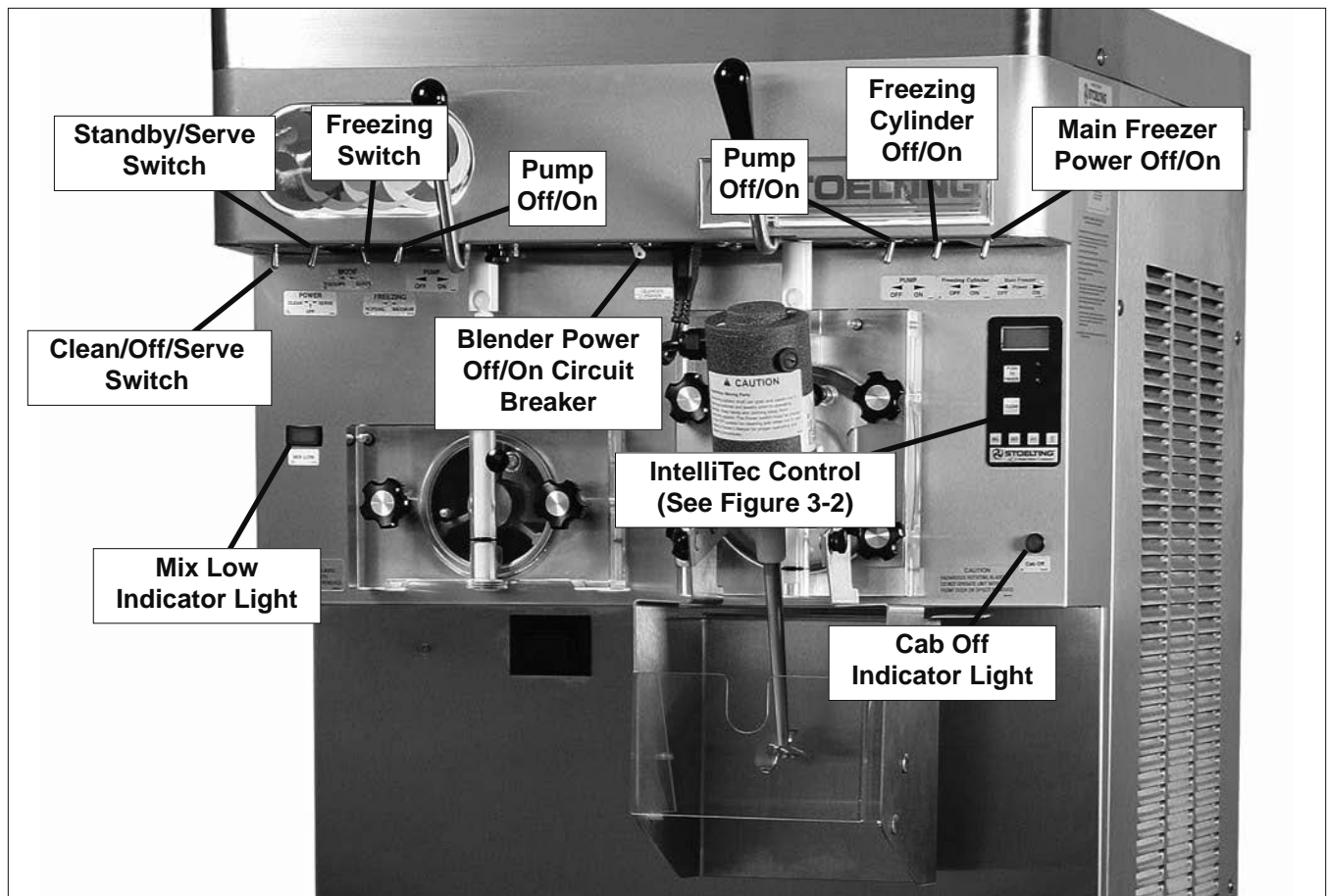

Figure 3-1 SU444 Freezer Controls

C. FRONT DOOR SAFETY SWITCH (BOTH SIDES)

The front door safety switch prevents the auger from turning when the front door is removed. The switch is open when the door is removed and closed when the door is properly installed.

D. DRIVE MOTOR OVERLOAD (BOTH SIDES)

The drive motor overload will trip if the drive motor is overloaded. Single phase machines have an internal overload and three phase machines have an external overload. The overload will reset after approximately 10-12 minutes. If the drive motor continues to trip, refer to the Troubleshooting Section.

E. DISPENSE RATE ADJUSTOR (LEFT SIDE)

The dispense rate adjustor is located under the header panel, to the immediate right of each spigot handle. Turning the knob counterclockwise will decrease the dispense rate.

F. CLEAN/OFF/SERVE SWITCH (LEFT SIDE)

The CLEAN-OFF-SERVE switch is a three position toggle switch used to control the operation of the refrigeration system and auger. When the switch is placed in the CLEAN position, the refrigeration system will be off and auger will rotate for cleaning. When the switch is placed in the OFF position, the refrigeration system and auger will not operate. When the switch is placed in the SERVE position, the refrigeration system and auger will operate automatically. The switch should be placed in the SERVE position for normal operation.

G. STANDBY/SERVE SWITCH (LEFT SIDE)

The standby/serve switch is a two position toggle switch. When the switch is placed in the standby position the machine will cycle to maintain a temperature below 41°F (-15°C). When the switch is in the Serve position the machine will cycle to maintain a servable product.

H. FREEZING SWITCH (LEFT SIDE)

The freezing switch is a two position toggle switch. When the switch is placed in the MAXIMUM position the machine will be forced to run 30 seconds after the spigot is closed if the temperature control is satisfied.

I. LOW MIX LIGHT (LEFT SIDE)

The low mix light will illuminate when the liquid level in the mix container drops below the mix low level indicator. (To adjust the indicator see Section 2.6 C.)

J. MAIN FREEZER POWER SWITCH (RIGHT SIDE)

The Main Freezer Power switch is a two position rocker switch that supplies power to the IntelliTec control, the right freezing cylinder circuits and the cabinet refrigeration system. When the switch is placed in the ON position, the cabinet refrigeration system will run until the preset temperature is reached; then it will cycle ON and OFF to maintain that temperature. Power to the right side freezing cylinder can then be controlled with the Freezing Cylinder OFF/ON switch.

K. FREEZING CYLINDER OFF/ON SWITCH (RIGHT SIDE)

The Freezing Cylinder OFF/ON switch is a two position toggle switch used to supply power to the right freezing cylinder control circuit. When the switch is in the OFF position, the freezing cylinder's refrigeration system and auger will not operate. When the switch is in the ON position, the machine will be operational.

L. BLENDER POWER OFF/ON AND CIRCUIT BREAKER SWITCH (RIGHT SIDE - SU444 ONLY)

The Blender Power Off/On and Circuit Breaker switch is a two position toggle switch used to supply power to the blender. When the switch is in the OFF position, there is no power to the blender. When the switch is in the ON position, the blender will operate any time the spigot handle is pushed to the right. This switch also serves as a circuit breaker to interrupt power if the rotation of the blender agitator becomes hindered.

M. CAB OFF INDICATOR LIGHT (RIGHT SIDE)

A flashing light indicates the Main Freezer Power Switch is in the OFF position; no refrigeration is being supplied to the cab. Place the Main Freezer Power switch in the ON position for cab refrigeration.

N. PUSH TO FREEZE BUTTON (RIGHT SIDE)

The PUSH TO FREEZE button is a snap switch used to initiate "Serve Mode".

NOTE

After the PUSH TO FREEZE button is pressed, the drive motor starts. After a 3-second delay, the compressor will start.

O. LEDS (RIGHT SIDE)

The membrane switch (touchpad) features two lights: a green LED and an amber LED. The green LED is lit during "Serve Mode". During freeze down, it is not lit. When product consistency approaches 75% in the freezing cylinder, the green LED flashes. The amber LED is on during all other modes. Both LEDs alternatively flash if an error occurs or if the freezing cylinder is off.

P. CLEAN BUTTON (RIGHT SIDE)

The CLEAN button is a snap switch. When the button is pressed, the freezing cycle stops and the drive motor will start. A CLEAN message will display on the LCD screen along with a 5-minute countdown timer. To exit the CLEAN mode, turn the Freezing Cylinder OFF/ON switch to the OFF position or press the CLEAN button again. If the machine is left in CLEAN for more than 20 minutes, an error code (E4) will be displayed on the display panel. Place the Freezing Cylinder OFF/ON switch in the OFF position and back in the ON position to clear this error.

Q. MIX LOW LIGHT INDICATOR (RIGHT SIDE)

A MIX LOW message will appear on the LCD display to alert the operator of a low mix condition. The message will display when there is approximately one gallon of mix left in the mix container. When the MIX LOW message is displayed, refill the container or replace a bag immediately.

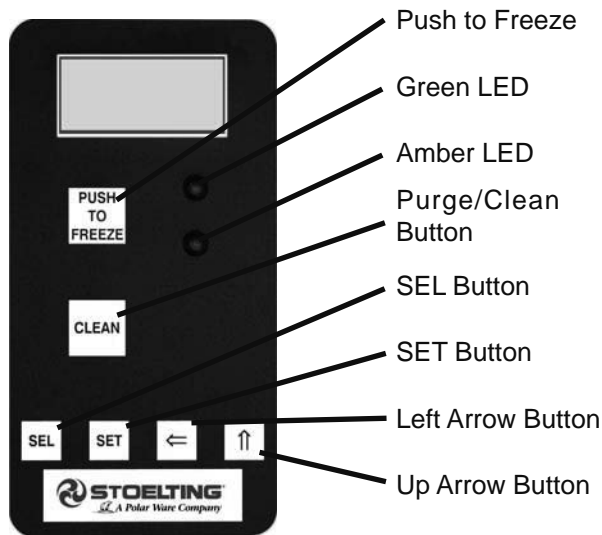

Figure 3-2 IntelliTec Control

R. MENU NAVIGATION BUTTONS (RIGHT SIDE)

The Menu Navigation Buttons allow the user to display information regarding the machine's status of operation as well as adjust product consistency (Fig. 3-2).

Selection Button (SEL) The SEL button is used in combination with the left arrow button to enter into the settings of the IntelliTec control. This button is also used to navigate through the control settings menu.

Set Button (SET) The SET button is used to save a change made to the product consistency setting. It is also used to save changes when modifying control settings.

Left Arrow Button (⇐) If the left arrow button is pressed for 5 seconds, the display will remain lit. To turn the light off, press the left arrow button for 5 seconds. The left arrow button is used primarily to navigate through the control settings.

Up Arrow Button (↑) After pressing the SET button, the up arrow button will change the value of the product consistency setting. This button is used primarily to navigate through the control settings.

3.3 IMPORTANT INFORMATION REGARDING CLEANING AND SANITIZING

Soft serve and shake machines require special consideration when it comes to food safety and proper cleaning and sanitizing.

The following information specifically covers issues for cleaning and sanitizing frozen dessert machines. This information is meant to supplement a comprehensive food safety program.

SOIL MATERIALS ASSOCIATED WITH FROZEN DESSERT MACHINES

MILKFAT/BUTTERFAT – As components of ice-cream/frozen custard mix, these soils will accumulate on the interior surfaces of the machine and its parts. Fats are difficult to remove and help attribute to milkstone buildup.

MILKSTONE – Is a white/gray film that forms on equipment and utensils that are exposed to dairy products. These films will accumulate slowly on surfaces because of ineffective cleaning, use of hard water, or both. Milkstone is usually a porous deposit, which will harbor microbial contaminants and eventually defy sanitizing efforts.

Once milkstone has formed, it is very difficult to remove. Without using the correct product and procedure, it is nearly impossible to remove a thick layer of milkstone.

(NOTE: general-purpose cleaners DO NOT remove milkstone.) This can lead to high bacteria counts and a food safety dilemma.

IT IS BEST TO CONTROL MILKSTONE ON A DAILY BASIS BEFORE IT CAN BECOME A SIGNIFICANT FOOD SAFETY PROBLEM.

In addition to food safety, milkstone can cause premature wear to machine parts, which can add to costs for replacement parts or possibly more expensive repairs if worn machine parts are not replaced once they have become excessively worn.

IMPORTANT DIFFERENCES BETWEEN CLEANING AND SANITIZING

CLEANING vs. SANITIZING

It is important to distinguish between cleaning and sanitizing. Although these terms may sound synonymous, they are not. BOTH are required for adequate food safety and proper machine maintenance.

CLEANING

- Is the removal of soil materials from a surface.
- Is a prerequisite for effective sanitizing.

NOTE

An UNCLEAN surface will harbor bacteria that can defy sanitizing efforts.

Bacteria can develop and resist sanitizing efforts within a layer of soil material (milkstone). Thorough cleaning procedures that involve milkstone removal are critical for operators of frozen dessert machines.

SANITIZING

- Kills bacteria.
- Can be effective on clean surfaces only.

NOTE

Using a SANITIZER on an unclean surface will not guarantee a clean and safe frozen dessert machine.

PROPER DAILY MAINTENANCE:

The Only Way to Assure Food Safety and Product Quality

Proper daily maintenance can involve a wide variety of products and procedures. Overall, the products and procedures fall into three separate categories. (Please note that this is a brief overview intended for informational purposes only.)

1. **CLEANING** – This involves draining mix from the freezing cylinder and rinsing the machine with water. Next, a cleaner is run through the machine. Then, the machine is disassembled and removable parts are taken to the sink for cleaning.
2. **MILKSTONE REMOVAL** – Since most cleaners do not have the ability to remove milkstone, the use of a delimer becomes necessary. Although this procedure may not be needed on a daily basis, it will usually follow the cleaning procedure. It requires letting a delimer solution soak in the machine for an extended period. Individual parts are also soaked in a deliming solution for an extended period of time (more about delimers in Additional Information).
3. **SANITIZING** – After the machine has been cleaned and contains no milkstone, the machine is reassembled. Then a FDA-approved sanitizing solution is run through the machine to kill bacteria. The machine is then ready for food preparation.

As a recommended cleaner and sanitizer for your frozen dessert machine, STERA-SHEEN has proven to be one of the best daily maintenance products for:

- **CLEANING** – Thorough removal of all solids including butterfat and milk fat.
- **MILKSTONE REMOVAL** – Complete removal of milkstone.
- **SANITIZING** – FDA-approved no rinse sanitizer for food contact surfaces.

ADDITIONAL INFORMATION

THE USE OF DELIMERS

A delimer is a strong acid that has the ability to dissolve milkstone. This type of chemical may become necessary once high levels of milkstone have developed. While these products are very effective for removing HIGH levels of milkstone, they are not ideal for two reasons:

1. **PRODUCT SAFETY** – Strong acids are dangerous chemicals. Carefully follow safety instructions provided with delimer products.
2. **MACHINE DAMAGE** – Strong acids will attack metal and rubber causing premature wear of parts. The use of a delimer needs to be closely monitored to avoid damage to machine surfaces and parts.

With proper daily use of STERA-SHEEN or its equivalent, there is no need for the use of a DELIMER.

DO NOT USE BLEACH

- **BLEACH HAS ABSOLUTELY NO CLEANING PROPERTIES.**
- **BLEACH IS CORROSIVE.** It will damage components of the machine causing premature wear and metal corrosion.

GENERAL PURPOSE CLEANERS

General purpose cleaners do not have the ability to remove milkstone. Milkstone will become a problem if not remedied with additional products and procedures.

THE USE OF CHLORINE TEST STRIPS

“Test strips” are used to determine concentrations of active chlorine in sanitizing solutions. To use the strips, tear off a small portion and submerge it into the sanitizing solution. Then, compare the color change to the color key on the side of the test strip dispenser to determine the approximate chlorine concentration.

The ideal concentration of chlorine needs to be 100 ppm (as stated by the FDA).

NOTE

Follow the directions on the container for proper concentration.

Two main factors contribute to falling chlorine concentrations in a sanitizing solution.

1. **PRODUCT USE** – As the chlorine in the solution is being used, chlorine concentrations fall.
2. **TIME** – As time passes, small amounts of chlorine “evaporate” from the solution. (That is why you can smell it.)

Sanitizing solutions should not be allowed to fall below 100 ppm chlorine. New solutions should be mixed once old solutions become ineffective.

3.4 DISASSEMBLY OF LEFT SIDE



WARNING

Moving machinery can grab, mangle and dismember. Place the Clean/Off/Serve switch in the OFF position before disassembling for cleaning or servicing.

Before using the machine for the first time, complete machine disassembly, cleaning and sanitizing procedures need to be followed. Routine cleaning intervals and procedures must comply with the local and state health codes. Inspection for worn or broken parts should be made at every disassembly of the machine. All worn or broken parts should be replaced to ensure safety to both the operator and the customer and to maintain good machine performance and a quality product.

To disassemble the left side, refer to the following steps:

A. REMOVE FRONT DOOR AND AUGER

1. Make sure the Clean/Off/Serve switch is in the OFF position
2. Remove the knobs on the front door and remove the door by pulling it off the studs.
3. Remove the air bleed valve by unscrewing the knob while holding the valve stem from behind. Remove the compression spring and push the air bleed valve through the rear of the front door.

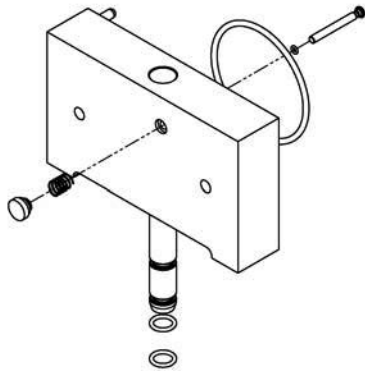

Figure 3-2 Left Side Front Door

4. Remove the spigot through the bottom of the front door. Remove all o-rings from the spigot and the air bleed valve.
5. Remove the front auger support and plastic bearing.
6. Remove the auger by pulling slowly and rotating out of the machine barrel. As the auger is withdrawn, remove each plastic flight and spring from the auger. Be careful not to scratch inside of machine barrel when removing flights or auger. Remove the spring from each auger flight.
7. Keep the rear of the auger tipped up once it is clear of the freezing cylinder to prevent the rear seal assembly from dropping.
8. Wipe the spline lubricant off the hex end of the auger with a paper towel. Remove the rear seal assembly.

NOTE

Keep the rear seal assembly separate from the right side assembly to prevent problems when assembling.

3.5 DISASSEMBLY OF RIGHT SIDE



WARNING

Moving machinery can grab, mangle and dismember. Place the Main Freezer Power Off/On switch in the OFF position before disassembling for cleaning or servicing.

Before using the machine for the first time, complete machine disassembly, cleaning and sanitizing procedures need to be followed. Routine cleaning intervals and procedures must comply with the local and state health codes. Inspection for worn or broken parts should be made at every disassembly of the machine. All worn or broken parts should be replaced to ensure safety to both the operator and the customer and to maintain good machine performance and a quality product.

To disassemble the machine, refer to the following steps:

A. REMOVE BLENDER (SU444 ONLY)

1. Make sure the Main Freezer Power Off/On switch is in the OFF position.
2. Unplug the blender.
3. Remove the blender agitator by holding the blender shaft and turning the agitator counterclockwise. Remove the blender shaft by holding the blender collar and turning the shaft counterclockwise. (Figure 3-3)

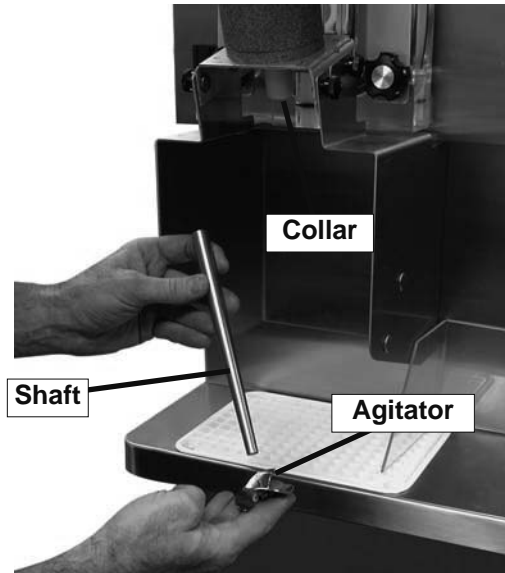

Figure 3-3 SU444 Blender Agitator Assembly

4. Loosen knobs holding the blender splash shield bracket in place and remove the bracket.
5. Remove the knobs on the front door. Remove the blender assembly and set aside.

NOTE

Support the blender with one hand while removing the knobs on the door to prevent the blender from dropping.

B. REMOVE FRONT DOOR AND AUGER

1. Make sure the Main Freezer Power Off/On switch is in the OFF position
2. Remove the knobs on the front door and remove the door by pulling it off the studs.

3. Remove the air bleed valve by unscrewing the knob while holding the valve stem from behind. Remove the compression spring and push the air bleed valve through the rear of the front door.
4. Remove the spigot through the bottom of the front door. Remove all o-rings from the spigot and the air bleed valve.
5. Remove the plastic bearing. The plastic bearing may be on the front door.
6. Remove the auger by pulling slowly. Be careful not to scratch the inside of the freezing cylinder when removing the auger.
7. Keep the rear of the auger tipped up once it is clear of the freezing cylinder to prevent the rear seal assembly from dropping.
8. Wipe the hex drive anti-seize off the hex end of the auger with a paper towel. Remove the rear seal assembly.

NOTE

Keep the rear seal assembly separate from the right side assembly to prevent problems when assembling.

3.6 CLEANING DISASSEMBLED PARTS

Disassembled parts require complete cleaning, sanitizing and air drying before assembling. Local and state health codes will dictate the procedure required. Some state health codes require a four sink process (pre-wash, wash, rinse, sanitize, air dry), while others require a three sink process (without the pre-wash step). The following procedures are a general guideline only. Consult your local and state health codes for the procedures required in your location.

- A. Disassemble all parts.
- B. Place all front door and auger parts in clean 90° to 110°F (32°C to 43°C) water and wash thoroughly (four sink procedure only).

CAUTION

The blender motor cannot be immersed in water or sanitizer. Wash the motor and mounting bracket with a mild detergent solution taking care not to allow water into the motor bearings or seals.

- C. Place all parts in 90° to 110°F (32°C to 43°C) mild detergent water and wash thoroughly.
- D. Rinse all parts with clean 90° to 110°F (32°C to 43°C) water.
- E. Sanitize all machine parts following procedures outlined below.

3.7 SANITIZING PARTS

- A. Use a sanitizer, mixed according to manufacturer's instructions, to provide a 100 parts per million strength solution. Mix sanitizer in quantities of no less than 2 gallons of 90° to 110°F (32°C to 43°C) water. Any sanitizer must be used only in accordance with the manufacturer's instructions.
- B. Place all parts in the sanitizing solution for 5 minutes, then remove and let air dry completely before assembling in machine.

3.8 CLEANING THE MACHINE

The exterior should be kept clean at all times to preserve the luster of the stainless steel. A high grade of stainless steel has been used on the machine to ease cleanup. To remove spilled or dried mix, wash the exterior with 90° to 110°F (32°C to 43°C) soapy water and wipe dry.

Do not use highly abrasive materials, as they will mar the finish. A mild alkaline cleaner is recommended. Use a soft cloth or sponge to apply the cleaner. For best results, wipe with the grain of the steel.

- A. Clean the rear seal surfaces on the inside of the freezing cylinders.
- B. Using sanitizing solution and the large barrel brush provided, sanitize the freezing cylinders by dipping the brush in the sanitizing solution and brushing the inside of the freezing cylinders.
- C. Remove the drip trays from the front panel. Clean and replace the drip trays.

3.9 ASSEMBLING THE LEFT SIDE

Refer to the following steps for assembling the left freezing cylinder:

NOTICE

Petrol-Gel sanitary lubricant or equivalent must be used when lubrication of machine parts is specified.

NOTICE

The United States Department of Agriculture and the Food and Drug Administration require that lubricants used on food processing equipment be certified for this use. Use lubricants only in accordance with the manufacturer's instructions.

- A. Assemble all o-rings onto parts dry, without lubrication. Then apply a thin film of sanitary lubricant to exposed surfaces of the o-rings.
- B. Install the rear seal o-ring. Lubricate the outside of the rear seal o-ring with sanitary lubricant.

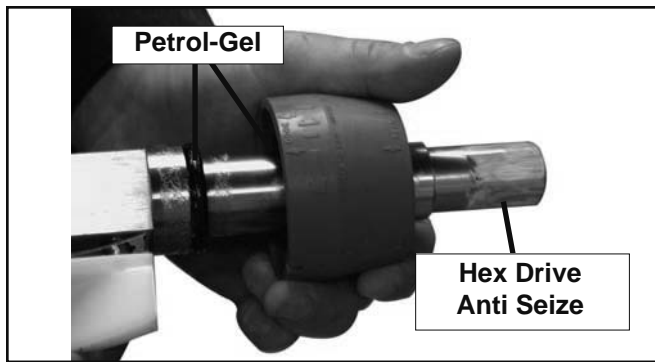

Figure 3-4 Rear Seal Assembly

- C. Install the stainless steel rear seal adapter into the rear seal dry (without lubricant). Lubricate the inside surface of the rear seal adapter and install it onto the auger shaft. DO NOT lubricate the outside of the rear auger seal (Fig. 3-4).

NOTE

Make sure to install the correct rear seal adapter onto the auger. The front door will not close if the right side rear seal adapter is installed onto the left side auger.

- D. Lubricate the hex drive end of the auger with a small amount of spline lubricant. A small container of anti seize is shipped with the machine.
- E. Screw the springs onto the studs in the plastic flights. The springs must be screwed into the flights completely to provide proper compression.
- F. Install the two plastic flights onto the rear of the auger and insert it part way into the freezing cylinder.
- G. Install the remaining plastic flights, push the auger into the freezing cylinder and rotate slowly until the auger engages the drive shaft.
- H. Apply a thin layer of sanitary lubricant to the inside and outside of the auger support bushing. Install the bushing onto the auger support and install the auger support into the front of the auger. Rotate the auger support so that one leg of the support points straight up.
- I. Assemble the air bleed valve o-ring onto the air bleed valve. Position the o-ring into the groove close to the wide part. Apply a thin film of sanitary lubricant to the o-ring.
- J. Insert the air bleed valve into the back of the front door. Install the compression spring onto the air bleed valve then screw the knob on finger tight.
- K. Apply a thin layer of sanitary lubricant to the o-rings on the spigot body and install the spigot body through the bottom of the front door.
- L. Place the front door assembly on the mounting studs and the push front door against the machine carefully.

- M. Secure the front door to the machine by placing the knobs on the studs and tightening until finger tight. Do not overtighten. Proper o-ring seal can be observed through the transparent front door.

3.10 ASSEMBLING THE RIGHT SIDE

Refer to the following steps for assembling the right freezing cylinder:

NOTICE

Petrol-Gel sanitary lubricant or equivalent must be used when lubrication of machine parts is specified.

NOTICE

The United States Department of Agriculture and the Food and Drug Administration require that lubricants used on food processing equipment be certified for this use. Use lubricants only in accordance with the manufacturer's instructions.

- A. Assemble all o-rings onto parts dry, without lubrication. Then apply a thin film of sanitary lubricant to exposed surfaces of the o-rings.
- B. Install the rear seal o-ring. Lubricate the outside of the rear seal o-ring with sanitary lubricant.
- C. Install the stainless steel rear seal adapter into the rear seal dry (without lubricant). Lubricate the inside surface of the rear seal adapter, including the adapter o-ring, and install it onto the auger shaft. DO NOT lubricate the outside of the rear auger seal.

NOTE

Make sure to install the correct rear seal adapter onto the auger. The back of the cylinder will leak if the left side rear seal adapter is installed onto the right side auger.

- D. Lubricate the hex drive end of the auger with a small amount of spline lubricant. A small container of anti seize is shipped with the machine.
- E. Install the plastic scraper blades onto the auger and insert the auger into the freezing cylinder.
- F. Rotate the auger until it engages the drive shaft.
- G. Assemble the air bleed valve o-ring onto the air bleed valve. Position the o-ring into the groove close to the wide part. Apply a thin film of sanitary lubricant to the o-ring.
- H. Insert the air bleed valve into the back of the front door. Install the compression spring onto the air bleed valve then screw the knob on finger tight.
- I. Install the spigot through the bottom of the front door.
- J. Apply a thin film of sanitary lubricant to the inside and outside of the plastic bearing, then place it into the front door.

- K. Place the front door assembly on the mounting studs and the push front door against the machine carefully.
- L. On the SU444, place the blender assembly onto the front door studs.
- M. Secure the front door to the machine by placing the knobs on the studs and alternately tightening opposite corners until finger tight. Do not overtighten. Proper o-ring seal can be observed through the transparent front door.
- N. On the SU444, attach the blender shroud to the blender assembly. The blender shroud has a pin that needs to be properly aligned with the machine safety switch.

3.11 SANITIZING

Sanitizing must be done after the machine is clean and just before the machine is filled with mix. Sanitizing the night before is not effective. However, you should always clean the machine and parts after using it.

NOTE

The United States Department of Agriculture and the Food and Drug Administration require that all cleaning and sanitizing solutions used with food processing equipment be certified for this use.

When sanitizing the machine, refer to local sanitary regulations for applicable codes and recommended sanitizing products and procedures. The frequency of sanitizing must comply with local health regulations. Mix sanitizer according to manufacturer’s instructions to provide a 100 parts per million strength solution. Mix sanitizer in quantities of no less than 2 gallons of 90°F to 110°F (32°C to 43°C) water. Allow sanitizer to contact the surfaces to be sanitized for 5 minutes. Any sanitizer must be used only in accordance with the manufacturer’s instructions.

CAUTION
<p>Risk of Product Damage</p> <p>Avoid prolonged contact of sanitizer with machine parts. Sanitizer may cause corrosion of stainless steel parts if there is prolonged contact.</p>

SANITIZING THE LEFT SIDE

- A. Prepare 3 gallons of sanitizing solution following manufacturer’s instructions, and pour into storage container.
- B. Place the mix pump switch in the ON position and open air bleed valve on the front door by pushing valve in and holding.
- C. Let sanitizing solution fill the machine barrel to air bleed valve, then close the valve by pulling out to lock in place.

- D. Place the CLEAN-OFF-SERVE toggle switch in the CLEAN position.
- E. Check for leaks when the machine barrel is first pressurized with sanitizing solution.
 1. Check for leaks at the plastic front door, the O-rings may not be sealed.
 2. Check the drain located at the center of the Drip Tray for leaks coming from the rear of the Rear Auger Seal.
 3. Check inside cab unit for leaks at hose connections.
- F. Using a sanitized soft bristle brush or equivalent, dipped in sanitizing solution, clean mix container.
- G. After five minutes, open spigot to drain sanitizing solution.
- H. Empty any remaining sanitizing solution from the mix container.
- H. Close the spigot and place the mix pump switch and the CLEAN-OFF-SERVE switch in the OFF position.

SANITIZING THE RIGHT SIDE

- A. Prepare 3 gallons of sanitizing solution following the manufacturer’s instructions. Pour it into a clean container and place the container into the cabinet.
- B. Place the mix pump switch in the ON position and open the air bleed valve on the front door by pushing the valve in and holding.
- C. Let sanitizing solution fill the freezing cylinder to the air bleed valve. Close the valve by pulling it out to lock it into place.
- D. Place the Main Freezer Power OFF/ON and Freezing Cylinder OFF/ON switches in the ON position. Press the CLEAN button.
- E. Check for leaks when the freezing cylinder is first pressurized with sanitizing solution.
 1. Check for leaks at the front door seals.
 2. Check the drain tray located in the side panel for leaks coming from the rear of the rear auger seal.
 3. Check the inside of the cab unit for leaks at the hose connections.
- F. Using a sanitized soft bristle brush (or equivalent) dipped in sanitizing solution, clean the mix container.
- G. After five minutes, open the spigot to drain the sanitizing solution.
- H. Empty any remaining sanitizing solution from the mix container.

- I. When the solution has drained, press the CLEAN button to stop the auger and place the Main Freezer Power OFF/ON and Freezing Cylinder OFF/ON switches in the OFF position. Allow the freezing cylinder to drain completely.
- J. Sanitize the agitator and shaft with a cup filled with sanitizing solution.

The machine is now sanitized and ready for adding mix.

3.12 INITIAL FREEZE DOWN AND OPERATION

Every Stoelting machine needs to be set on site. The following information is for the right side and only needs to be performed during the initial startup or when changing the type of mix.

NOTE

The machine is designed for correct operation in ambient temperatures between 50°F and 110°F. Temperatures out of that range may cause refrigeration problems and product quality issues.

A. ADDING MIX

1. Sanitize the machine immediately before use.
2. Make sure the Freezing Cylinder OFF/ON switch is in the OFF position.
3. Fill the mix container in the cab with at least 2.5 gallons of mix.
4. Attach the mix inlet probe to the container and place the container in the refrigerated cab.
5. The mix pump switch is located on the header panel. Place it in the ON position.
6. Place a container under the spigot and open the spigot to allow the mix to flush out about 8 ounces (0.23 liters) of sanitizing solution and liquid mix. Close the spigot.
7. Open the air bleed valve on the front door by pressing and holding. Hold the valve open until the mix level in the freezing cylinder is 1/2" from the air bleed valve.

B. PREPARING THE INTELLITEC CONTROL

8. On the IntelliTec control, press and hold the SEL button for 8 seconds. While still holding the SEL button, press the up arrow (↑) button. The LCD will read "DISPLAY".
9. Press the left arrow (←) button once. The display will read "BASIC".
10. Press the up arrow (↑) button once. The display will read "CutOut amps".
11. Press the SET button. A cursor will start blinking under the far right digit.
12. Change the value to 8.0. Press the left arrow (←) button to move the cursor. Press the up arrow (↑) button to increase the digit. When a digit reaches 9, pressing the up arrow (↑) button again will change the value to 0.

13. After entering 8.0, press SET to save this value. The LCD will read "CutOut Set — OK".
14. Press the SEL button. The LCD will read "CutOut amps 8.0".
15. Press the SEL button twice. The LCD will read "DISPLAY".
16. Press the up arrow (↑) button to navigate to the "°F" and "amps" readings.

C. INITIAL FREEZE DOWN

17. Place the Freezing Cylinder OFF/ON switch in the ON position.
18. Press the PUSH TO FREEZE button.

NOTE

After the drive motor starts, there is a 3-second delay before the compressor starts.

19. As the product freezes, the "amps" value on the display will increase. When it reaches 2.8A, open the spigot, take a 6-8 ounce sample and measure the temperature. For most shake mixes, the desired temperature is between 23.5°F and 24.0°F.

CAUTION

Do not exceed 3.5 amps when setting the control.

20. Draw samples at every increase of 0.2A until reaching the desired consistency and temperature.

NOTE

Show the sample to the customer and make sure it meets their required consistency and temperature.

21. Record the "amps" value.
22. Place the Freezing Cylinder OFF/ON switch in the OFF position.

D. ADJUSTING THE INTELLITEC CONTROL

23. Press the SEL button. The display will read "DISPLAY".
24. Press the left arrow (←) button once. The display will read "BASIC".
25. Press the up arrow (↑) button once. The display will read "CutOut amps".
26. Change the value to the recorded value by pressing the SET button. A cursor will start blinking under the far right digit.
27. Press the left arrow (←) button to move the cursor. Press the up arrow (↑) button to increase the digit. When a digit reaches 9, pressing the up arrow (↑) button again will change the value to 0.
28. Press the SET button to save the value. The LCD will read "CutOut Set — OK".

29. Press the SEL button. The LCD will read “CutOut amps” along with the programmed value from the previous step.
30. Press the SEL button three times. The LCD will read “EXITMENU”.
31. Press the up arrow (↑) button to exit the menu.
32. Adjustment to the control is completed.

E. SERVING PRODUCT

33. Place the Freezing Cylinder OFF/ON switch in the ON position.
34. Press the PUSH TO FREEZE button.
35. When the product is at 75% consistency, the display will read “SERVE”.
36. For normal dispensing, move the spigot handle fully open.
37. The machine dispenses product at a reasonable draw rate. If the machine is overdrawn, the result is a soft product or a product that will not dispense at all. If this occurs, allow the machine to run for approximately 30 seconds before dispensing more product.
38. Do not operate the machine when the MIX LOW message is displayed. Refill the mix container immediately.

NOTE

The right side has a standby and sleep mode. After a preset number of freezing cycles, it will enter the standby mode (followed by sleep mode) and remain there until someone draws product or presses the PUSH TO FREEZE button. In the sleep mode, the machine will keep the product below 41°F (7.2°C). Sleep modes do not take the place of cleaning and sanitizing. Federal, State, and local regulatory agencies determine frequency of cleaning and sanitizing.

3.13 NORMAL FREEZE DOWN AND OPERATION

Refer to the following procedures to operate both freezing cylinders.

- A. Sanitize immediately before use.
- B. Make sure the Clean/Off/Serve switch (left side) or the Freezing Cylinder Off/On switch (right side) is in the OFF position.
- C. Fill the storage container in the cab with at least 2.5 gallons of mix.
- D. Attach the mix inlet probe to the container and place the container in the refrigerated cab.
- E. Place the mix pump switch in the ON position.

- F. Place a container under the spigot and open it to allow the mix to flush out about 8 ounces (0.23 liters) of sanitizing solution and liquid mix. Close the spigot.
- G. Open the air bleed valve on the front door by pressing and holding. Hold the valve open until the mix level in the freezing cylinder is 1/2” from the air bleed valve.
- H. Place the Clean/Off/Serve switch (left side) or the Freezing Cylinder Off/On switch (right side) in the ON position. On the SU444 right side, make sure the blender power plug is connected to the machine and place the Blender Power Off/On switch in the ON position.



WARNING

Hazardous Moving Parts

Blender shaft and agitator can grab and cause injury. Do not operate blender without protective shield or swing splash shield.

- I. On the right side, press the PUSH TO FREEZE button.

NOTE

After the drive motor starts, there is a 3-second delay before the compressor starts.

- J. Product will be ready as follows:
On the left side, the product will be ready to serve after about 3 cycles.
On the right side, the display will read “SERVE” when the product is at 75% consistency.
- K. For normal dispensing, fully open the spigot handle.
- L. On the SU444 right side, push the spigot handle to the right to activate the blender. The blender will operate during or after dispensing product.
- M. Do not operate the right side when the MIX LOW message is displayed and do not operate the left side when the mix low indicator light is on. Refill the mix containers immediately.

NOTE

The right side has a standby and sleep mode. After a preset number of freezing cycles, it will enter the standby mode (followed by sleep mode) and remain there until someone draws product or presses the PUSH TO FREEZE button. In the sleep mode, the machine will keep the product below 41°F (7.2°C). Sleep modes do not take the place of cleaning and sanitizing. Federal, State, and local regulatory agencies determine frequency of cleaning and sanitizing.

3.14 MIX INFORMATION

Mix can vary considerably from one manufacturer to another. Differences in the amount of butterfat content and quantity and quality of other ingredients have a direct bearing on the finished frozen product. A change in machine performance that cannot be explained by a technical problem may be related to the mix.

Proper product serving temperature varies from one manufacturer's mix to another. Mixes should provide a satisfactory product in the 20°F to 24°F range. Diet and low-carb mixes typically freeze to proper consistency at higher temperatures.

When checking the temperature, stir the thermometer in the frozen product to get an accurate reading.

Old mix, or mix that has been stored at too high a temperature, can result in a finished product that is unsatisfactory. To retard bacteria growth in dairy based mixes, the best storage temperature range is between 33° to 38°F (0.5° to 3.3° C).

3.15 OPERATION OF MIX PUMP

The mix pump switches are located under the header panel. When a pump switch is placed in the ON position, the mix pump motor will start pumping mix into the freezing cylinder. When the set pressure is reached, the mix pump will shut off automatically. When the switch is placed in the OFF position, the mix pump will not operate.

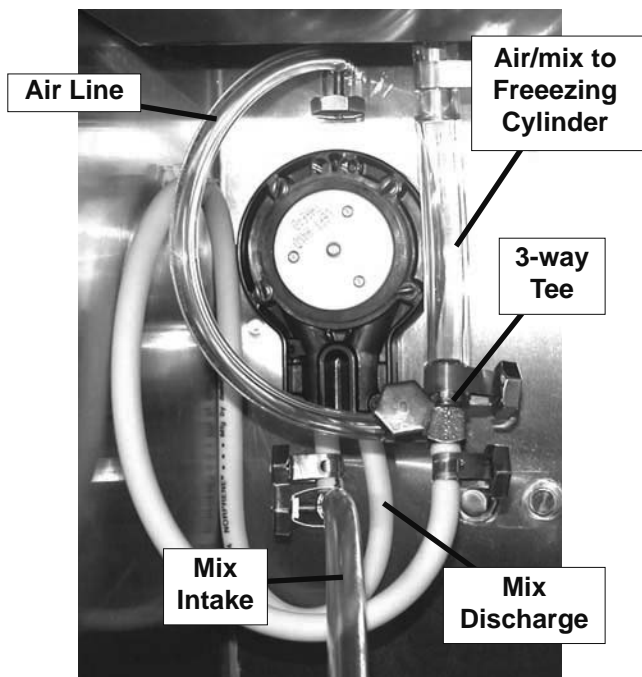

Figure 3-5 Mix Pump Hose Routing

NOTE

The mix pump motor is equipped with an internal overload that will “trip”, disabling the pump when the motor is overloaded. Consult the troubleshooting section for corrective information. The internal overload will automatically reset after cooling. If the condition continues, contact a qualified service person.

- A. Mix Operation: The peristaltic mix pump contains one continuous mix pump hose. When looking at the face of the peristaltic mix pump, the left side of the hose is the mix intake or pickup. The right side of the hose is the mix discharge. Mix is drawn up the pickup side of the hose and transferred through the discharge side to the machine (Fig. 3-6).
- B. Air Operation: The air compressor operates whenever the peristaltic mix pump is running. Air enters through a check valve on the piston downstroke. The air is discharged through a second check valve, on the piston upstroke. The air and mix join at the tee and then travel to the machine.
- C. The overrun adjustment is preset at the factory. If an adjustment becomes necessary, refer to Section 4.

3.16 MIX PUMP CLEANING

NOTICE

Any cleaning procedure must always be followed by sanitizing before filling machine with mix. (Refer to Section 3.11)

The mix pump is approved for CIP (clean in place). It is thoroughly cleaned when the detergent solution is pumped through the machine. We recommend completely disassembling the pump and disconnecting tubing every 14 days for inspection of parts to confirm the CIP has been properly performed. If any residue is detected, clean or replace those parts as outlined below.

- A. Place the Main Freezer Power OFF/ON switch and the Freezing Cylinder OFF/ON switch in the ON positions. Make sure both Pump OFF/ON switches are in the ON position. Place the Clean/Off/Serve switch (Left Side) in the CLEAN position and press the CLEAN button (Right Side). Allow the auger to agitate for 5 to 10 minutes.
- B. Remove the suction tube from the mix container. Open the spigot to remove the mix remaining in the freezing cylinder.
- C. Pump 2 gallons (7.5 liters) of potable water through machine until the water coming out of the spigot is clear.

- D. Pump 2 gallons (7.5 liters) of 90° to 110°F (32°C to 43°C) detergent solution through the machine. The use of soft water is recommended, along with dishwashing detergents such as “Joy,” “Dawn,” or equivalent.
- E. Place the mix pump switch in the OFF position. Open the spigot to relieve the remaining pressure.
- F. Place the Clean/Off/Serve switch (Left Side) in the OFF position and press the CLEAN button (Right side) to stop the augers. Place the Main Freezer Power OFF/ON switch and the Freezing Cylinder OFF/ON switch in the ON positions.

3.17 DISASSEMBLY AND INSPECTION OF REMOVABLE PARTS

Inspection of removable parts should be made whenever maintenance is performed or when the pump requires disassembly.

NOTE

If the mix line or air line is difficult to remove, soften the tubing with a rag soaked in hot water. Hose connections may be sprayed with Haynes Sanitary Lubricant for ease of removal.



WARNING

Hazardous Moving Parts

Revolving pump head can grab, mangle, and cause serious crushing injury. The Main Freezer Power OFF/ON switch, the Clean/Off/Serve switch and the Freezing Cylinder OFF/ON switch must be placed in the OFF position for cleaning and power must be disconnected when disassembling or servicing.

CAUTION

System Under Pressure

Never disconnect hoses from the machine or the pump without first opening the spigot to relieve pressure.

- A. Loosen the clamp and remove the air hose from the pump compressor.
- B. Loosen the clamp and disconnect the mix pump hose. Remove the pickup hose, and the mix pickup assembly from the mix container.
- C. Completely disassemble the hose assembly and the check valve (Fig. 3-6). Place hoses, tee, check valve assembly, and pickup hose adapter in 90° to 110°F (32°C to 43°C) mild detergent water and wash thoroughly. Use soft bristle brushes to clean inside of fittings. Rinse all parts in clean 90° to 110°F (32°C to 43°C) water.
- D. Carefully inspect each part for wear or damage. Replace worn or damaged parts.
- E. Wash the mix tube and the air tube in the cabinet with 90° to 110°F detergent water and brushes provided. Rinse with clean, 90° to 110°F water.
- F. Prepare two gallons (7.5 liters) of sanitizing solution using a USDA certified grade sanitizing solution. Sanitize all removed parts. Allow them to air dry.
- G. Reassemble both hose assemblies per the diagram located on the inside of the cab door. Reconnect the assemblies to the pump hose and the discharge hose, using the clamps. (Refer to Section 2.5 Mix Pump).
- H. Sanitize assembled machine as per instructions outlined in Section 3.11.



Figure 3-6 Mix Pump Removable Parts

SECTION 4 MAINTENANCE AND ADJUSTMENTS

4.1 MACHINE ADJUSTMENT

This section is intended to provide maintenance personnel with a general understanding of machine adjustments. It is recommended that any adjustments in this section be made by a qualified person.

4.2 PRODUCT TEMPERATURE ADJUSTMENT (LEFT SIDE)

A potentiometer is used to control the product temperature. To change the temperature of the product, follow the steps below:

- Remove the header panel.
- Use a screw driver to make desired adjustment. A label near the potentiometer will give complete instructions.



Figure 4-1 Left Side Product Temperature Control

4.3 PRODUCT CONSISTENCY ADJUSTMENT (RIGHT SIDE)

The operator can adjust product consistency by modifying the Fine Adjustment setting on the membrane switch. This is the only adjustment that can be made by the operator without using a pass code key sequence. Product consistency fine adjustment allows a 0.4 amp maximum adjustment to the drive motor amp draw cutout. Increasing this setting will increase the drive motor amperage cutout and increase product consistency. Follow the instructions below to make fine adjustments to product consistency.

- Place the Main Freezer Power switch in the ON position.
- Press the SET button on the Control Panel once. Fine Adj will appear on the LCD screen.
- Press the up arrow button (↑) until the desired consistency setting is displayed. The higher the number, the firmer the product consistency. The

control may be set from 1 to 9. The value increases by 1 each time the up arrow button is pressed. After the value reaches 9, numbering restarts at 0. The 0 setting cannot be set.

- Press the SET button once to save the setting and return to the current mode display.

4.4 LOCKING THE CONTROL PANEL (RIGHT SIDE)



Figure 4-2 Right Side Membrane Switch

The IntelliTec control has a tamper proof mode to prevent unauthorized use. When set, all buttons on the control panel are disabled. Follow the instructions below to lock the control panel

- Press and hold the PUSH TO FREEZE button for at least 5 seconds.
- While still holding the PUSH TO FREEZE button, press the CLEAN button once.
- Release both buttons. An asterisk (*) will appear on the bottom line of the display, indicating that the control is in the lock out mode.

NOTE:

Repeat steps A, B, and C to unlock the control panel.

4.5 OBTAINING READINGS AND MODIFYING SETTINGS (SERVICE PERSONNEL ONLY) (RIGHT SIDE)

Readings and settings on the IntelliTec control are accessed through the IntelliTec control menu settings. Locating machine readings and system function settings are done using the up arrow (↑) and left arrow (←) buttons on the membrane switch. A printed IntelliTec Menu Settings sheet is located in the information pouch behind the header panel.

IntelliTec Control Readings

To obtain machine readings, locate the value on the machine's menu settings sheet and follow the steps below.

- A. Press and hold the SEL button for 8 seconds. While still holding the SEL button, press the up arrow button (↑). The LCD screen will read DISPLAY.
- B. Release both buttons.
- C. Press the up arrow button (↑) to navigate to the correct reading under DISPLAY or press the left arrow (←) button to navigate to the ERRCODES menu.
- D. Press the up arrow (↑) and left arrow (←) buttons to navigate through the rest of the readings as needed.
- E. When all readings have been obtained, press the up arrow button (↑) from ExitMenu to return to the current mode display.

Modifying Control Settings

To change the value of a system function, locate the function on the IntelliTec Settings Menu and follow the steps below.

IMPORTANT:

Before making changes to any settings, record the original values. If the setting changes do not achieve desired results, return settings to their original values.

- A. Press and hold the SEL button for 8 seconds. While still holding the SEL button, press the up arrow button (↑). The LCD Screen will read DISPLAY.
- B. Release both buttons.
- C. Press the left arrow button (←) to get to the correct menu (Basic, Advanced, or Storage).
- D. Press the up arrow button (↑) to navigate to the value that needs to be changed.
- E. Press the SET button to enter the edit mode.
- F. Press the up arrow button (↑) to change the setting.
- G. Press the SET button to save the setting and exit the edit mode.
- H. Press the up arrow (↑) and the left arrow (←) buttons to navigate through the rest of the settings as needed.
- I. When all changes have been completed, press the up arrow button (↑) from ExitMenu to return to the current mode display.

4.6 READINGS (SERVICE PERSONNEL ONLY) (RIGHT SIDE)

The IntelliTec control continuously monitors and records temperatures, voltages, amps, and error code details. Each reading is beneficial to service personnel when troubleshooting.

DISPLAY READINGS

Following are the readings available under the DISPLAY menu:

Cabinet

The temperature of the cab is constantly monitored by the IntelliTec control.

Cycles (count)

This reading counts down the number of cycles in the current "Serve Mode". The starting value is dependant upon the Cycles setting on the IntelliTec control.

°F and amps

Suction line temperature on the freezing cylinder and drive motor amps are available on the same screen to assist with setup and troubleshooting.

Aux. Temp (°F)

This reading provides the ambient temperature around the IntelliTec control board.

Supply V (VAC)

A calculated input voltage is recorded.

ERROR CODE READINGS

The following details are recorded under the ERRCODES menu for each of the last 25 error codes received:

Err1 (hours)

A numerical count of the last 25 error codes is recorded. When the 26th error has occurred, the earliest error code is erased. A timer also begins when an error occurs. The timer records the number of hours since the error occurred. If power to the machine is interrupted, the timer will stop until power has been restored.

°F and amps

The suction gas temperature on the freezing cylinder and the drive motor amps are recorded at the time of the error.

Aux. Temp (°F)

Ambient temperature of the IntelliTec control board is recorded at the time of the error.

Str (°F)

The storage temperature is recorded at the time of the error.

VAC and Mode

A calculated input voltage and mode at which the error occurred are recorded. Following are descriptions of each mode:

Mode	Description
0	Start of freezing cycle
1	Compressor and drive motor on
2	Stir Cycle
3	Compressor off
4	“Standby Mode”
5	“Sleep 1 Mode”
6	“Sleep 2 Mode”
7	“Clean Mode”
8	Startup
9	Storage only refrigeration
10	Freezing cycle is shut down
11	Door safety switch triggered
12	High pressure cutout

Up Time (hours)

This value is a record of the total time the machine has been in service. If power is interrupted, the timer will stop until power is restored. This timer does not reset.

RUN STATISTICS

In addition to dynamic readings and recorded error code details, the IntelliTec control records rolling averages of run statistics. Following are the readings available under the RUNSTATS menu:

On Times (sec)

The control records the time of each freezing cycle and provides a rolling average.

Off Times (sec)

The control records the time between freezing cycles and provides a rolling average.

Brl. Min (°F)

The lowest average barrel temperature is recorded.

Brl. Max (°F)

The highest average barrel temperature is recorded.

Stor Min (°F)

The lowest average cabinet temperature is recorded.

Stor Max (°F)

The highest average cabinet temperature is recorded.

Power On (hrs)

This value is a record of the time the machine has been in service. If power is interrupted, the timer will reset.

4.7 ADJUSTMENTS (SERVICE PERSONNEL ONLY) (RIGHT SIDE)

The following adjustments directly affect product consistency and length of time in “Serve Mode”. The default settings have been created using a 5% milkfat soft serve mix and provide optimal product consistency while prolonging product life.

CutOut (amps)

It is recommended to set the CutOut value at initial startup and when changing mix types. Adjustments to this setting directly affect the length of the freezing cycle which changes product consistency. To properly set the CutOut value, refer to section 3-10.

Cut In T (°F)

After the consistency value has been determined, the Cut In T value can be adjusted. The Cut In T is the temperature of the refrigerant gas in the evaporator. Changing this setting changes the temperature at which the freezing cycle starts. This value along with the CutOut value determines the range of temperatures (or “temperature window”) of the product. Decreasing the temperature decreases the temperature window and, under normal use, increases the amount of freezing cycles. This creates a greater chance of product breakdown by stirring the product often. Increasing the Cut In T increases the temperature window, which decreases freezing cycles and increases the chance of heat shock within the product.

Cycles (count)

This setting determines the number of freezing cycles during “Serve Mode”. Increasing the value will increase the total time in “Serve Mode”. Factory default is 20 cycles, which results in “Serve Mode” lasting about 2-1/2 hours without the PUSH TO FREEZE button being pressed or a spigot handle being pulled. If the PUSH TO FREEZE button is pressed or the spigot handle is pulled at any time during “Serve Mode”, the Cycles count will reset.

4.8 OTHER SETTINGS (SERVICE PERSONNEL ONLY) (RIGHT SIDE)

Changing any setting on the IntelliTec control will alter machine operation and affect the product temperature, consistency, or life. Refer to the IntelliTec Control System Settings sheet located in the information pouch behind the header panel of the machine. If any of the following settings on the IntelliTec control differ from the System Settings sheet, it is recommended to return those settings to factory defaults.

Stir On (sec)

Adjustments to this setting affect the amount of time the auger rotates in the stir cycle. The stir cycle occurs in "Serve Mode", "Standby Mode", and "Sleep 2 Mode".

Stir Off (sec)

Adjustments to this setting affect the time between stir cycles. The stir cycle occurs in "Serve Mode", "Standby Mode", and "Sleep 2 Mode".

On Time (sec)

Increasing this value will increase the length of the freezing cycle during "Standby Mode".

Off Time (sec)

Increasing this value will increase the time between freezing cycles in "Standby Mode" and result in an increase of product temperature in the barrel.

Stb Time (sec)

This setting determines the total amount of time in "Standby Mode".

SI1DrvOn (sec)

Adjustments to this setting affect the amount of time the auger rotates in the stir cycle. This stir cycle only occurs in "Sleep 1 Mode".

SI1DrOff (sec)

Adjustments to this setting affect the time between stir cycles. The stir cycle only occurs in "Sleep 1 Mode".

SI2CutIn (°F)

Changing this setting affects the temperature at which the freezing cycle starts in "Sleep 2 Mode".

SI2CtOut (°F)

Changing this setting affects the temperature at which the freezing cycle stops in "Sleep 2 Mode".

DftOffTm (sec)

In "Serve Mode", this value determines the maximum time without a freezing cycle. If this value is met, a freezing cycle will start. In the event of a freezing cylinder temperature sensor failure, this value affects the amount of time between freezing cycles during "Serve Mode".

Refriger

This setting changes how the control handles the storage refrigeration cycle. The correct setting for the SU444 and U444A is Cabinet.

CabCutIn (°F)

If the Refriger value is set to Cabinet, this setting determines the temperature at which the refrigeration cycle starts. If None, 1 Hopper, or 2 Hopper is selected for the Refriger setting, CabCutIn will not be shown on the IntelliTec menu.

CabCtOut (°F)

If the Refriger value is set to Cabinet, this setting determines the temperature at which the refrigeration cycle stops. If None, 1 Hopper, or 2 Hopper is selected for the Refriger setting, CabCtOut will not be shown on the IntelliTec menu.

Cab Off

If the Refriger value is set to Cabinet and the temperature sensor in the cabinet fails, this setting determines the time between refrigeration cycles. If None, 1 Hopper, or 2 Hopper is selected for the Refriger setting, Cab Off will not be shown on the IntelliTec menu.

Cab On

If the Refriger value is set to Cabinet and the temperature sensor in the cabinet fails, this setting determines the length of the refrigeration cycle. If None, 1 Hopper, or 2 Hopper is selected for the Refriger setting, Cab On will not be shown on the IntelliTec menu.

4.9 OVERRUN ADJUSTMENT

The product, when served, is a combination of air and mix. Overrun is a measure of the amount of air blended into the mix.

Overrun can be expressed in terms of the amount of weight loss for a given volume. For example, if a pint of liquid mix weighs 18 ounces and a pint of frozen product with air added weighs 12 ounces, the overrun is said to be 50 percent: $18 \text{ oz.} - 12 \text{ oz.} = 6 \text{ oz.}$, $(6/12) \times 100 = 50\%$

The overrun can be checked by placing a one pint container on an ice cream scale and zeroing out the scale. Then fill a one pint container with frozen product. The container should be filled over the top and leveled with a straightedge. The product should not contain any air pockets. When weighed on an ice cream scale, one pint of product should weigh 12 to 13 ounces.

The mix pump has been preset at the factory to produce a product with approximately 40% overrun. Because of differences in mix formulation, temperatures and barometric pressure, this figure may vary. It will be necessary for approximately 2 gallons of mix to be pumped through the machine before overrun changes in the product are noticeable.

Overrun is controlled by the length of the air compressor piston stroke within the piston cylinder. Lengthening the stroke within the cylinder will increase overrun. Conversely, shortening the stroke will decrease overrun. To perform an overrun adjustment, refer to the following procedure:

 WARNING
Hazardous voltage The Clean/Off/Serve and the Main Freezer Power Off/On switches must be placed in the OFF position when disassembling for servicing. The freezer must be disconnected from electrical supply before removing any access panel. Failure to disconnect power before servicing could result in death or serious injury.

- A. Turn the mix pump switch to the OFF position. Disconnect power sources/circuit breakers.
- B. Remove the back panel from the machine.
- C. On the air compressor side of the pump, locate the long/slender piston rocking arm. The rocking arm downward travel is limited by a stationary cam. On the face of the cam there is an overrun setting indicator plate numbered 3 through 8 and an adjustment knob (Fig. 4-3).
- D. The overrun setting is indicated by a pin.
- E. To adjust overrun, loosen the allen-head screw (located within the center of the adjustment knob) with the 5/32" allen wrench provided. Rotate the adjustment knob counterclockwise to a higher number for higher overrun, or clockwise to a lower number for lower overrun. Each number multiplied by 10 represents the overrun percentage (i.e. setting 4 = 40% overrun).



Figure 4-3 Overrun Adjustment

- F. Tighten the allen screw, then place the wrench back in its clip. Replace the lower back panel and secure with the four screws. Turn the mix pump power switch to the ON position.

4.10 MIX PUMP HOSE REPOSITION

Mix pump hose must be repositioned every 800 gallons of mix pumped or every 2 weeks. Failure to reposition the hose will result in reduced mix pump liquid capacity, dispense stoppage, popping, and possible mix pump hose leakage. Follow the steps below to reposition the hose:

- A. Run cleaning solution through pump.
- B. Turn the pump off and relieve any pressure by opening the spigot.
- C. Grasp the pickup hose end of the mix pump hose with one hand and turn the pump on. Pull down on the pickup hose end until 12 to 14 inches of tubing has fed through the pump then turn the pump off (Fig. 4-4).
- D. Loosen the small clamp at the pick-up hose adapter and disconnect the mix pump hose.
- E. Cut 7-1/2 inches off the end of the mix pump hose.
- F. Reconnect the mix pump hose to the adapter.
- G. Continue normal operation. Mix hose will automatically reposition itself with the adapter near the black cover.

NOTE

Each hose is long enough for 3 repositions before replacement is required.

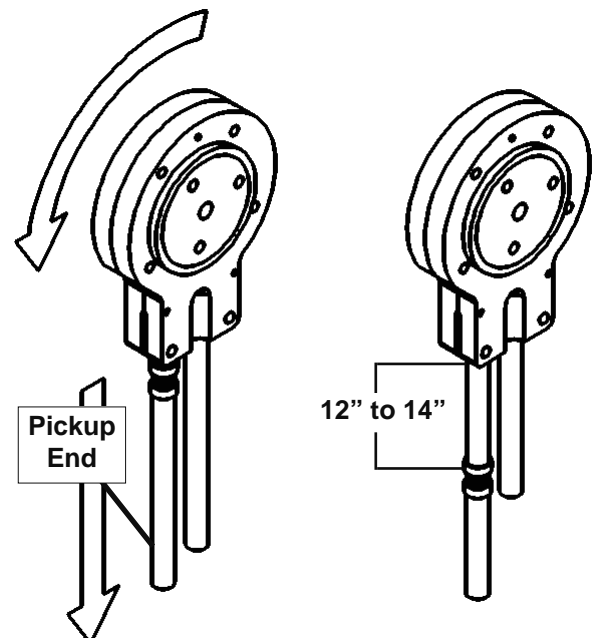

Figure 4-4 Pump Hose Reposition

4.11 MIX PUMP HOSE REPLACEMENT

Mix pump hose must be replaced when tubing cannot be further repositioned (every four to eight weeks). Failure to comply will result in hose failure and possible pump damage. Follow the steps below to replace the hose:

- A. Run cleaning solution through pump.
- B. Turn the pump off and relieve any pressure by opening the spigot.
- C. Disconnect the mix pump hose at each end.
- D. Grasp the discharge hose end with one hand and turn the pump on. Pull down on the hose until all of the remaining hose is removed from the pump. Turn pump off.
- E. Rotate pump roller assembly so one roller is at the 6:00 position.
- F. Use a brush that fits in the opening and clean the pump roller assembly, first with detergent water and then clear water.
- G. Connect the new mix pump hose to the pickup hose adapter using the small clamp.
- H. Feed one end of the mix pump hose into the pickup hose side (left) of the black cover.

NOTE

Feed the tube into the clamp so the natural curve of the tube is towards the outside of the black cover. This prevents the hose from looping around the black cover twice.

- I. Gently push the hose into the black cover until it begins to feed.
- J. Allow the hose to feed itself through the pump until about 6" (15cm) remains on the entering side.
- K. Turn pump off.
- L. Connect the mix pump hose to the elbow fitting (located on the left side of the mix line manifold) using a small hose clamp. Be careful not to twist the mix hose.
- M. Turn the pump on.
- N. Allow the remaining 6" (15cm) of tubing to feed through the pump until the hose adapter prevents further feeding.
- O. Turn the pump off.

CAUTION

Risk of Product Damage

Air/Mix Tee must remain below the black cover clamp. If the Tee is above the pump, the mix may drain into the air compressor, resulting in pump damage.

- P. Connect the free end of the mix pump hose to the 3-way Tee. When all connections are complete, the 3-way Tee must be lower than the black pump housing.
- Q. The pump is now ready to sanitize.

4.12 CAB TEMPERATURE ADJUSTMENT

Cab temperature is monitored and controlled by two settings on the IntelliTec control: CabCutIn and CabCtOut. The cut in value determines the temperature at which the refrigeration cycle starts. The cut out setting determines when the cycle stops. To change the CabCutIn or CabCtOut, follow the steps below:

- A. Press and hold SEL button for 8 seconds. While still holding the SEL button, press the up arrow button (↑). The LCD Screen will read "Display".
- B. Release both buttons.
- C. Press the left arrow button (←) three (3) times to navigate to the Storage menu.
- D. Press the up arrow button (↑) once to navigate to the CabCutIn value. Record this value.

IMPORTANT:

Before making changes to any settings, record the original values. If the setting changes do not achieve desired results, return settings to their original values.

- E. Press SET button to enter edit mode.
- F. Press the up arrow button (↑) to increase the number to the value required. The value increases by 1 each time the up arrow button (↑) is pressed. After the value reaches 9, numbering restarts at 0.
- G. Press SET button to save the setting and exit the edit mode.
- H. Press the up arrow button (↑) once to navigate to the CabCtOut value. Record this value.
- I. Press SET button to enter edit mode.
- J. Press the up arrow button (↑) to increase the number to the value required. The value increases by 1 each time the up arrow button (↑) is pressed. After the value reaches 9, numbering restarts at 0.
- K. Press SET button to save the setting and exit the edit mode.
- L. Press the up arrow (↑) and left arrow (←) buttons to navigate to ExitMenu.
- M. Press the up arrow button (↑) from ExitMenu to return to the Mode Screen.
- N. Locate the Specification Sheet for SU412 Control behind the header panel and record the new values on this sheet.

4.13 DRIVE BELT TENSION ADJUSTMENT

To check belt tension, follow the steps below:

- A. Remove a side panel and the back panel.

 WARNING
Hazardous voltage
The Clean/Off/Serve and the Main Freezer Power Off/On switches must be placed in the OFF position when disassembling for servicing. The freezer must be disconnected from electrical supply before removing any access panel. Failure to disconnect power before servicing could result in death or serious injury.

- B. Use a Burroughs Belt Tension Gauge to set the tension for the drive belt. Set the belt tension on the soft serve side to 45-55 lbs. Set the belt tension on the shake side to 35-45 lbs.
- C. If an adjustment is necessary, loosen the four motor plate retaining nuts, adjust belt tension then retighten the four nuts.

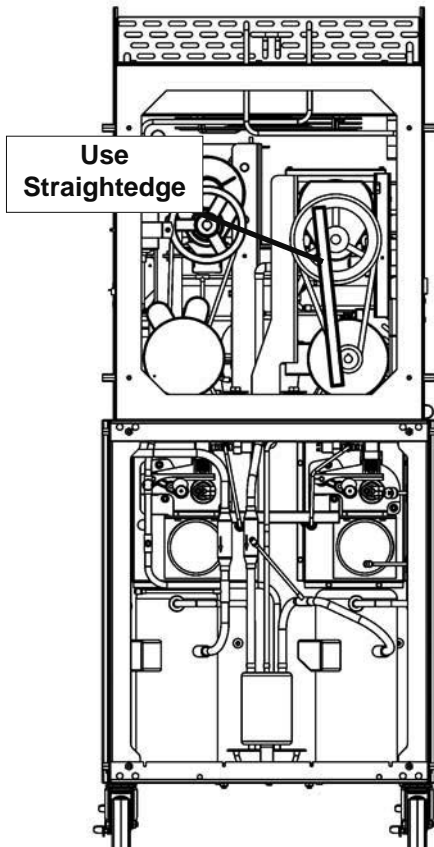

Figure 4-5 Pulley Alignment

- D. Using a straightedge, check that the drive motor pulley is aligned with the speed reducer pulley. Align the pulley if necessary.

NOTE

Belt life will be increased if new drive belts are tightened after two or three weeks of operation.

4.14 CONDENSER CLEANING (AIR-COOLED MACHINES)

The condenser requires periodic cleaning. To clean the condenser, refer to the following steps:

- A. Lift the condenser filter off of the machine cover panel. Visually inspect the condenser filter for dirt.
- B. If the condenser filter is dirty, vacuum or brush it clean. Rinse it with clean water and allow it to dry before replacing it on the machine.
- C. Visually inspect the condenser for dirt by shining a light through the coil of the condenser.
- D. If the condenser is dirty, place a wet towel over the condenser.
- E. Using compressed air or a CO2 tank, blow out the dirt from the inside of the condenser. Most of the dirt will cling to the wet towel.

NOTE

If the condenser is not kept clean, refrigeration efficiency will be lost.

4.15 PREVENTATIVE MAINTENANCE

It is recommended that a preventative maintenance schedule be followed to keep the machine clean and operating properly. The following steps are suggested as a preventative maintenance guide.

The United States Department of Agriculture and the Food and Drug Administration require that lubricants used in food zones be certified for this use. Use lubricants only in accordance with the manufacturer's instructions.

- A. Daily checks
- Check for any unusual noise or condition and repair immediately.
- B. Monthly checks
1. Check drive belts for wear and tighten belts if necessary. (Refer to section 4.12)
 2. Check the condenser filter for dirt. (Refer to section 4.13).

4.16 EXTENDED STORAGE

Refer to the following steps for winterizing the machine or for storing the machine over any long period.

- A. Clean all of the parts that come in contact with mix thoroughly with warm detergent . Rinse in clear water and dry all parts. Do not sanitize.

NOTE

Do not let cleaning solution stand in machine barrel or mix pump during the shutdown period.

- B. Remove, disassemble, and clean the front door, auger shaft, and mix pump. Leave disassembled during the shutdown period.
- C. Place the plastic auger flights in a plastic bag with a moist paper towel. This will prevent the flights from becoming brittle if exposed to dry air over an extended period (over 30 days).
- D. For water-cooled machines that are left in unheated buildings, or buildings subject to freezing, the water must be shut off and disconnected. Disconnect the water inlet fitting. The fitting is located at the rear of the machine. Run the compressor for 2 - 3 minutes to open the water valve (the front door must be attached for the compressor to run). Blow out all the water through the water inlet. Drain the water supply line coming to the machine. Disconnect the water outlet fitting.
- E. Disconnect the machine from the source of the electrical supply in the building.

SECTION 5 TROUBLESHOOTING

5.1 ERROR CODES (RIGHT SIDE)

When the right side experiences a problem, one of the following error codes will be displayed on the IntelliTec control. Each error code directs you to the system location of the malfunction.

ERROR CODE MALFUNCTION

1	Soft
2	High Torque
3	Extended Run Time
4	Clean
5	Barrel Sensor
6	Hopper Sensor
7	Drive Motor
8	Cab Sensor
9	High Pressure Cutout
10	Auxiliary Sensor
11	Low Temperature

To return the machine to normal operation, any error causing condition must be corrected and the Freezing Cylinder Off-On switch must be placed in the Off position and back in the On position before the affected side of the machine will return to normal operation.

5.2 TROUBLESHOOTING - ERROR CODES (RIGHT SIDE)

Error Code 1 - Soft Error

The Soft Error (E1) is an internal control board error that is logged for future analysis. The refrigeration is never stopped and the machine will continue to operate normally.

Error Code 2 - High Torque

If the control panel displays a High Torque Error (E2), the controller has sensed that the drive motor is running at 125% of the preset CutOut amp setting for 10 or more seconds. This may be due to the product consistency adjustment being set too high. Place the Main Power OFF/ON switch in the OFF position, wait until the product in the freezing cylinder thaws and return the switch to the ON position. Follow the instructions in Section 3 to reduce the product consistency by a few levels. If the error persists, contact your Authorized Stoelting Distributor for further assistance.

Error Code 3 - Run Time

The Run Time Error (E3) occurs when the compressor runs continuously for 20 minutes without the product reaching consistency in "Serve Mode" or if the product does not reach proper temperature in "Sleep 2 Mode". This error is generally caused by very low mix levels in the machine's mix container or from product breakdown. Another common cause results from a restriction preventing mix from entering the freezing cylinder. Check the mix in the cabinet. If the level mix is low, add mix. If there is a possibility that the mix has broken down, clean and sanitize the machine and replace the mix with fresh product.

Ice crystals in the liquid mix container can clog the mix inlet system and prevent mix from entering the freezing cylinder. Thoroughly thaw mix per manufacturer's recommendations. To check for ice crystals, pour a small amount of product from the mix container through a clean and sanitized sieve or strainer. If ice crystals are in the mix, check the temperature of the cabinet.

Check the condition of the neoprene hose running through the mix pump head. If it shows signs of wear, rotate or replace it.

In air cooled machines, the Run Time Error may indicate that airflow within the machine has reduced or stopped. Check the sides and top of the machine for anything that would restrict airflow.

If the error persists after attempting to clear it, contact your Authorized Stoelting Distributor for further assistance.

Error Code 4 - Clean

If the machine is left in the Clean Mode for more than 20 minutes, the control panel will display a Clean Error (Error 04). This condition does not reflect a problem with the machine itself. The Clean Error has been programmed into the controller as a safeguard to protect the machine from potential damage caused by the machine being accidentally left in "Clean Mode". The control will attempt to restart itself after 5 minutes. The display will then flash and read Restart. To immediately clear the Clean Error, place the Main Power Off-On switch in the Off position and back in the On position. After restarting the machine, a refrigeration cycle will begin to protect the product in case the clean button was pressed by mistake.

Error Code 5 - Freezing Cylinder Sensor

The Freezing Cylinder Sensor Error (E5) indicates a failure of the barrel sensor or an extreme out of range condition (< -34°F or > 99°F). If the control panel displays an E5, place the Freezing Cylinder Off-On switch in the Off position and back in the On position. If the error persists, contact your Authorized Stoelting Distributor for further assistance.

NOTE

When the machine encounters a Freezing Cylinder Sensor Error, the machine will continue to run using preset timers. This mode will allow the operator to continue serving product until the machine can be serviced.

Error Code 6 - Hopper Sensor (single hopper machines)

The Hopper Sensor Error (E6) will not occur on the SU444 machine.

Error Code 7 - Drive Motor

If the control panel displays a Drive Motor Error (E7), the control does not sense current coming from the drive motor. Place the Freezing Cylinder Off-On switch in the Off position and back in the On position. If the error persists, contact your Authorized Stoelting Distributor for further assistance.

Error Code 8 - Cab Sensor

A Cab Sensor Error (E8) indicates a cabinet temperature sensor failure or. This error will also appear in an extreme out of range condition (< -34°F or > 99°F). If the control panel displays an E8, place the Freezing Cylinder Off-On switch in the Off position and back in the On position. If the error persists, contact your Authorized Stoelting Distributor for further assistance.

Error Code 9 - High Pressure Cutout

High Pressure Cutout Errors (E9) are usually caused by a dirty or inefficient condenser.

In air cooled condenser models, check for proper air clearance around the machine.

In water cooled condenser models check for proper water flow.

If the error persists, contact your Authorized Stoelting Distributor for further assistance.

Error Code 10 - Auxiliary Sensor

An Auxiliary Temperature Sensor Error (E10) occurs if the temperature sensor on the control board fails. Place the Freezing Cylinder Off-On switch in the Off position and back in the On position. If the error persists, contact your Authorized Stoelting Distributor for further assistance.

Error Code 11 - Low Temperature

The Low Temperature Error (E11) occurs when the temperature of the gas refrigerant at the freezing cylinder sensor falls below -20°F. Although the machine will not shut down, the active freezing cycle will immediately end. This error usually occurs when the machine continues to run in a low mix condition or if the machine runs out of mix. The product towards the front of the freezing cylinder tends to freeze solid. When the temperature on the freezing cylinder lowers to the preset value, the IntelliTec control will display an E11.

ALTERNATING FLASHING CONTROL PANEL LIGHTS

The display panel lights will flash in an alternating sequence under any error codes. Clear the error and place the Freezing Cylinder Off-On switch in the Off position and back in the On position.

5.3 TROUBLESHOOTING - FREEZER

PROBLEM	POSSIBLE CAUSE	REMEDY
Drive motor (auger) “kicks-out”, or does not run.	<ol style="list-style-type: none"> 1 Power to machine is off. 2 Low line voltage. 3 Product too hard. 4 Front door not installed securely. 	<ol style="list-style-type: none"> 1 Check power to machine. 2 Check, must be $\pm 10\%$ of nameplate voltage. 3 Increase overrun. (See Section 4.9) 4 Install front door securely.
Compressor does not operate.	<ol style="list-style-type: none"> 1 Power to machine is off. 2 Drive motor overloaded or no current detected. 3 Low line voltage. 4 Compressor internal overload is cut-out. 5 Front door not installed securely. 	<ol style="list-style-type: none"> 1 Check power to machine. 2 Wait for 15-20 minutes for the thermal overload to reset. 3 Check, must be $\pm 10\%$ of nameplate voltage. 4 Check condenser (air cooled) (See Sect. 4.14), or water supply (water cooled). 5 Install front door securely.
Product too soft.	<ol style="list-style-type: none"> 1 Right side CutOut setting is too low 2 Left side temperature setting is too high. 3 Product breakdown. 4 Left side Standby/Serve switch in the Standby position 	<ol style="list-style-type: none"> 1 Adjust CutOut setting to match product requirements. (See Section 3.12) 2 Adjust the temperature. (See Section 4.2) 3 Fill with fresh product. 4 Place the Standby/Serve switch in the Serve position.
Freeze-up. (Product will not dispense easily.)	<ol style="list-style-type: none"> 1 Right side CutOut setting is too high. 2 Left side temperature setting is too low. 3 Low overrun setting. 4 Low pump pressure. 5 Large air pocket in barrel. 6 Auger turning counter-clockwise. 7 Pump hoses kinked. 	<ol style="list-style-type: none"> 1 Adjust CutOut setting to match product requirements. (See Section 3.12) 2 Adjust the temperature. (See Section 4.2) 3 Increase overrun. (See Section 4.9) 4 Check pump pressure. 5 Purge air from barrel. 6 Change rotation to clockwise. 7 Check pump hoses for bending or kinking.
Rear auger seal leaks.	<ol style="list-style-type: none"> 1 Seal missing or installed wrong. 2 Rear seal o-ring missing, broken or not lubricated. 3 Worn or scratched shaft. 	<ol style="list-style-type: none"> 1 Install correctly. (See Section 3.9 and 3.10) 2 Inspect for breakage and lubricate properly. (See Section 3.9 and 3.10) 3 Replace shaft.
Spigot leaks.	<ol style="list-style-type: none"> 1 Spigot parts are not lubricated. 2 Chipped or worn o-rings. 3 O-rings on spigot installed wrong. 4 Nicks or scratched on front door where spigot is located. 	<ol style="list-style-type: none"> 1 Lubricate. (See Section 3.9 and 3.10) 2 Replace o-rings. 3 Remove spigot and check o-rings. 4 Replace front door.

PROBLEM	POSSIBLE CAUSE	REMEDY
Drive belts slipping or squealing.	1 Drive belt tension not correct. 2 Worn belt(s). 3 Low overrun.	1 Adjust belt tension. (See Section 4.13) 2 Replace belts. 3 Check for air leak.
Mix temperature too warm in cab.	1 Temperature control set too warm. 2 Cab door is open.	1 Decrease CabCtOut and CabCutIn (See Section 4.12) 2 Close the cab door.
Mix temperature too cold in cab.	1 Temperature control set too cold.	1 Increase CabCtOut and CabCutIn (See Section 4.12)
Compressor makes loud noise	1 Reversed scroll rotation	1 Change wiring.
Fan motor doesn't operate or high head pressure	1 Left side not connected to power supply. 2 Low line voltage.	1 Make sure the left side is connected to a power supply. 2 If line voltage is less than 215V, then the fan motor needs to be rewired (See Section 2.4)
Not cooling at startup	1 Reversed scroll rotation	1 Check compressor for proper power and reverse wiring if necessary (3 phase only). (See Section 2.5)
IntelliTec displays CLEAN message (Right Side)	1 The cabinet temperature has been above 50°F for 2 hours or more.	1 Check the cabinet temperature. Disassemble and clean the machine. (See Sections 3.4 to 3.11)

5.4 TROUBLESHOOTING - MIX PUMP

PROBLEM	POSSIBLE CAUSE	REMEDY
Pump motor does not run.	<ol style="list-style-type: none"> 1 Power to pump is off. 2 Low voltage. 3 Mix pump hose jammed inside black cover/clamp. 4 Pump motor overloaded. 5 Pressure switch on pump is defective. 6 Defective motor/capacitor. 7 Defective toggle switch. 	<ol style="list-style-type: none"> 1 Supply power to pump. 2 Check for low voltage. 3 Disconnect pump from power source. Remove four cover/clamp thumb screws. Separate cover/clamp halves and remove outer half. Remove jammed hose. Clean and re-install cover/clamp and tighten four thumb screws securely. Allow motor thermal overload to reset. 4 Allow internal thermal overload to reset; determine overload cause and repair. 5 Check mechanical operation and continuity of pressure switch. 6 Check motor amperage draw and/or capacitor. Replace motor or capacitor. 7 Check continuity; repair or replace.
Pump operates but cylinder will not fill.	<p>Note 1: A properly working pump will fill an 8 oz. cup with mix in about 9 seconds.</p> <p>Note 2: Immediately after a bag change the pump may be unable to reestablish it's prime with the system at operating pressure. In this case, turn the pump off. Draw 2-3 pints to reduce system pressure to zero. Turn pump on. Purge remaining air in mix bag and pick-up hose.</p> <p>Important: before connecting the pick-up hose to the mix bag, remove as much air from the mix bag as possible.</p>	
	<ol style="list-style-type: none"> 1 Out of Mix. 2 Mix pump hose kinked inside black cover/clamp. 3 Hoses assembled incorrectly. 4 Mix pump hose service life is exceeded. 5 Mix pump hose not connected to machine. 6 Ice crystals in mix. 7 Mix bag drawn against adapter. 8 Foreign objects in mix. 9 Check valve is backwards. 	<ol style="list-style-type: none"> 1 Replenish mix supply. 2 Disconnect pump from power source. Remove four cover/clamp thumb screws. Separate cover/clamp halves and remove outer half. Remove jammed hose. Clean and re-install cover/clamp and tighten four thumb screws securely. Allow motor thermal overload to reset. 3 Refer to diagram for correct hose connections. 4 Reposition/replace mix pump hose. See Section 4.9 5 Connect mix pump hose to machine. 6 Completely thaw mix prior to use. 7 Ensure bag is clear of pick-up tube. 8 Clear blockage. Use fresh mix. 9 Observe flow arrow for proper orientation.
Overrun too low or no overrun.	<ol style="list-style-type: none"> 1 Overrun setting too low. 2 Air leak. 3 Air compressor not pumping air. 4 Air check valve in backwards. 	<ol style="list-style-type: none"> 1 Increase overrun setting. 2 Tighten all hose clamps. 3 Contact local Stoelting Distributor. 4 Check arrow for direction of flow.

PROBLEM	POSSIBLE CAUSE	REMEDY
Overrun too high.	<ol style="list-style-type: none"> 1 Mix pump hose service life is exceeded. 2 Out of mix. 3 Overrun setting too high. 4 Pick-up leg of mix pump hose is collapsing. 	<ol style="list-style-type: none"> 1 Reposition/replace mix pump hose. 2 Replenish mix supply. 3 Decrease overrun setting. 4 Reposition hose.
Replacement mix pump hose won't feed through pump.	<ol style="list-style-type: none"> 1 Feeding hose into discharge hole of mix pump cover. 2 Hose ends not cut squarely. 3 Force feeding too quickly. 4 Pump motor not running. 	<ol style="list-style-type: none"> 1 Feed hose into suction side of cover. 2 Carefully cut hose end off squarely (no tails). 3 Gently and slowly assist feeding of hose up into pick-up hose side of cover. 4 Turn on motor switch.
Air exiting mix pick-up hose.	<ol style="list-style-type: none"> 1 Pickup tube check valve missing. 	<ol style="list-style-type: none"> 1 Contact local Stoelting Distributor.
Dispensed product air "pops"	<ol style="list-style-type: none"> 1 Overrun setting too high. 2 Mix pump hose service life is exceeded. 3 Overdrawing the machine's capacity. 4 Recent low mix condition. 	<ol style="list-style-type: none"> 1 Decrease overrun setting. 2 Reposition/replace mix pump hose. 3 Reduce dispense rate. 4 Open spigot fully and allow excess air to escape.
Mix leakage from pump.	CAUTION: To prevent mix pump damage from dried mix deposits, immediately disassemble and clean pump.	
	<ol style="list-style-type: none"> 1 Mix pump hose service life is exceeded. 	<ol style="list-style-type: none"> 1 Remove mix pump hose. Disconnect pump from power source. Remove mix pump cover/clamp. Clean the rollers a small amount of soapy water. Clean mix from pump. See Section 4.2 for hose replacement.
Pump is noisy/squeaking.	<p>Note: The action of the air compressor rocking arm creates a repetitive clicking sound during operation. This is normal.</p> <p>Note: The peristaltic mix pump has three squeeze rollers that use self lubricating bearings. If squeaking exists with the mix pump hose in place and stops with the hose removed, the squeeze roller bearings can be lubricated using a silicone based spray. Remove the mix pump hose. Disconnect pump from electrical power. Remove four cover/clamp thumbscrews. Remove entire cover/clamp as one unit. Spray silicone based lubricant on each end of each squeeze roller. Spin rollers to work lubricant into bearings. Repeat as needed.</p> <p>Caution: Do not use cleaning/dissolving type lubricants like wd-40. These lubricants are not bearing friendly and will accelerate bearing wear.</p>	
Mix in air hoses.	<ol style="list-style-type: none"> 1 Air/mix tee above black cover/clamp. 2 Air leak. 3 Mix hose on wrong air/mix tee fitting. 	<ol style="list-style-type: none"> 1 Air/mix tee must be below black cover/clamp. 2 Check stainless steel tube connection. Tighten all hose clamps. 3 Refer to diagram for correct hose connections.

SECTION 6 REPLACEMENT PARTS

6.1 BRUSHES, DECALS AND LUBRICATION

Part Number	Description	Quantity
208135	Brush - 4" X 8" X 16" (Barrel)	1
208380	Brush - 1/4" X 3" X 14"	1
208387	Brush - 1/2" X 5" X 24"	1
208465	Brush - 1" X 3-1/2" X 18"	1
208467	Brush - 3/8" X 1" X 5"	1
324103	Decal - Caution Rotating Shaft	1
324105	Decal - Caution Electrical Shock	1
324106	Decal - Caution Electrical Wiring Materials	1
324107	Decal - Caution Hazardous Moving Parts	1
324125	Decal - Danger Electric Shock Hazard	1
324141	Decal - Caution Rotating Blades	1
324208	Decal - Attention Refrigerant Leak Check	1
324346	Decal - Caution Hazardous Moving Parts	1
324509	Decal - Cleaning Instructions	1
324548	Decal - Adequate Ventilation 6"	1
324565	Decal - Temperature Adjustment	1
324566	Decal - Wired According To	1
324594	Decal - Attention Heat Sensitive	1
324686	Decal - Danger Automatic Start	2
324728	Decal - Contactor Identification	1
324796	Decal - Freezing	1
324797	Decal - Standby / Serve	1
324798	Decal - Clean/Off/Serve Switch	1
324799	Decal - Pump Off / On	2
324801	Decal - Mix Low	1
324803	Decal - Domed Stoelting Logo (Large) (Header Panel)	1
324804	Decal - Domed Stoelting Swirl (Header Panel)	1
324825	Decal - Main Freezer Power	1
324826	Decal - Cab Off	1
324827	Decal - Freezing Cylinder	1
324835	Decal - Blender Power On / Off	1
324837	Decal - Caution Blender	1
324887	Decal - Boost Transformer	1
508048	Lubricant - Spline (2 oz Squeeze Tube)	1
508135	Petrol Gel - 4 oz Tube	1
513640	Manual - Service	1

6.2 LEFT SIDE SOFT SERVE AUGER SHAFT AND FRONT DOOR PARTS

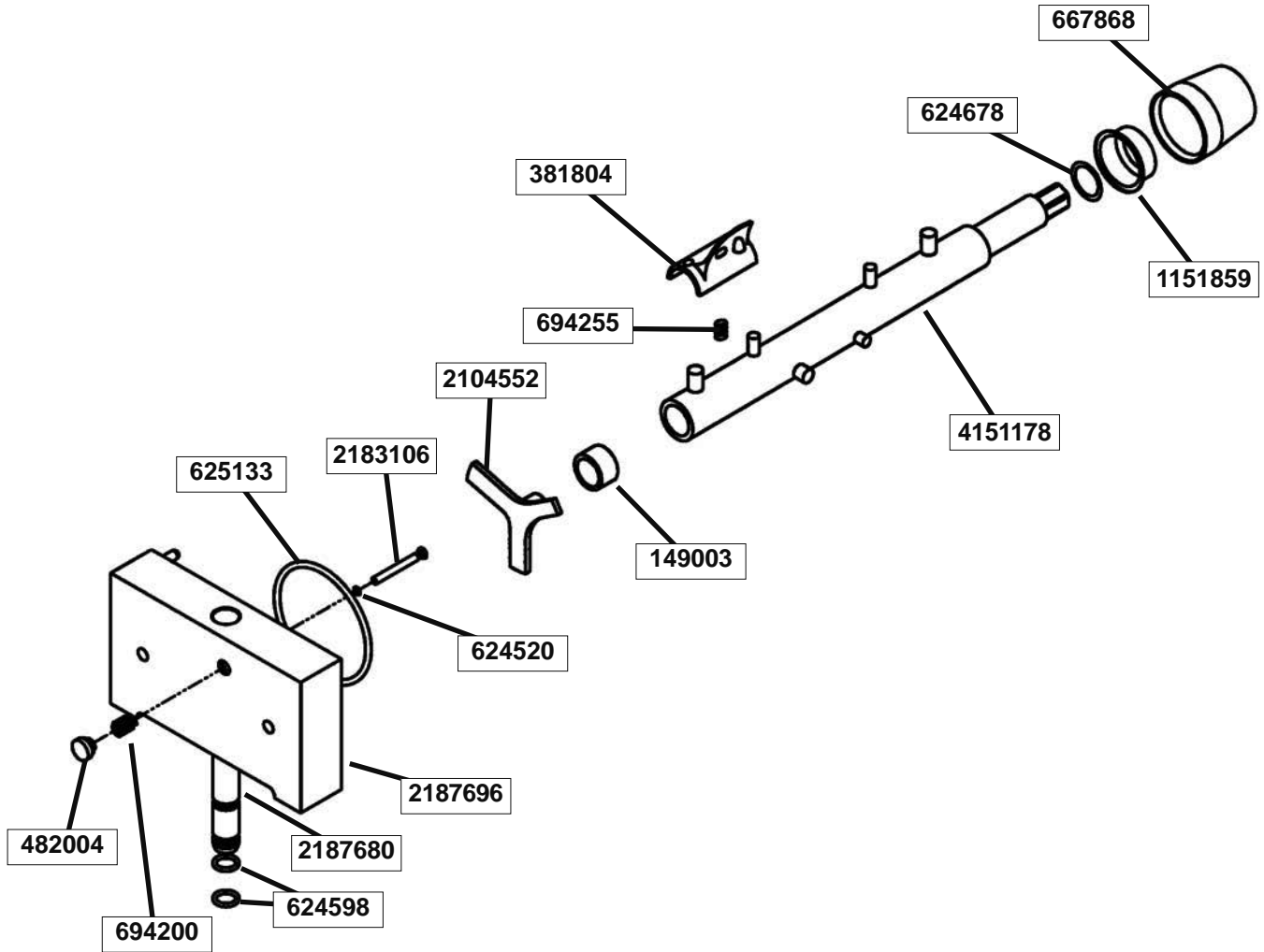

Part Number	Description	Quantity
149003	Bushing - Front Auger Support	1
381804	Auger Flight	6
482004	Knob (Air Bleed Valve & Blender Motor)	7
624520	O-Ring - Air Bleed Valve - Black	1
624598	O-Ring - Spigot - Black	2
624678	O-Ring - Rear Seal - Black	1
625133	O-Ring - Front Door - Black	1
667868	Seal - Rear Auger (Orange)	1
694200	Spring - Air Bleed Valve	1
694255	Spring - Auger Flight	6
1151859	Adapter - Rear Seal (Code 1)	1
2104552	Support - Front Auger	1
2183106	Valve - Air Bleed	1
2187680	Spigot Body	1
2187696	Front Door	1
4151178	Auger Shaft	1

6.3 RIGHT SIDE SHAKE AUGER SHAFT AND FRONT DOOR PARTS

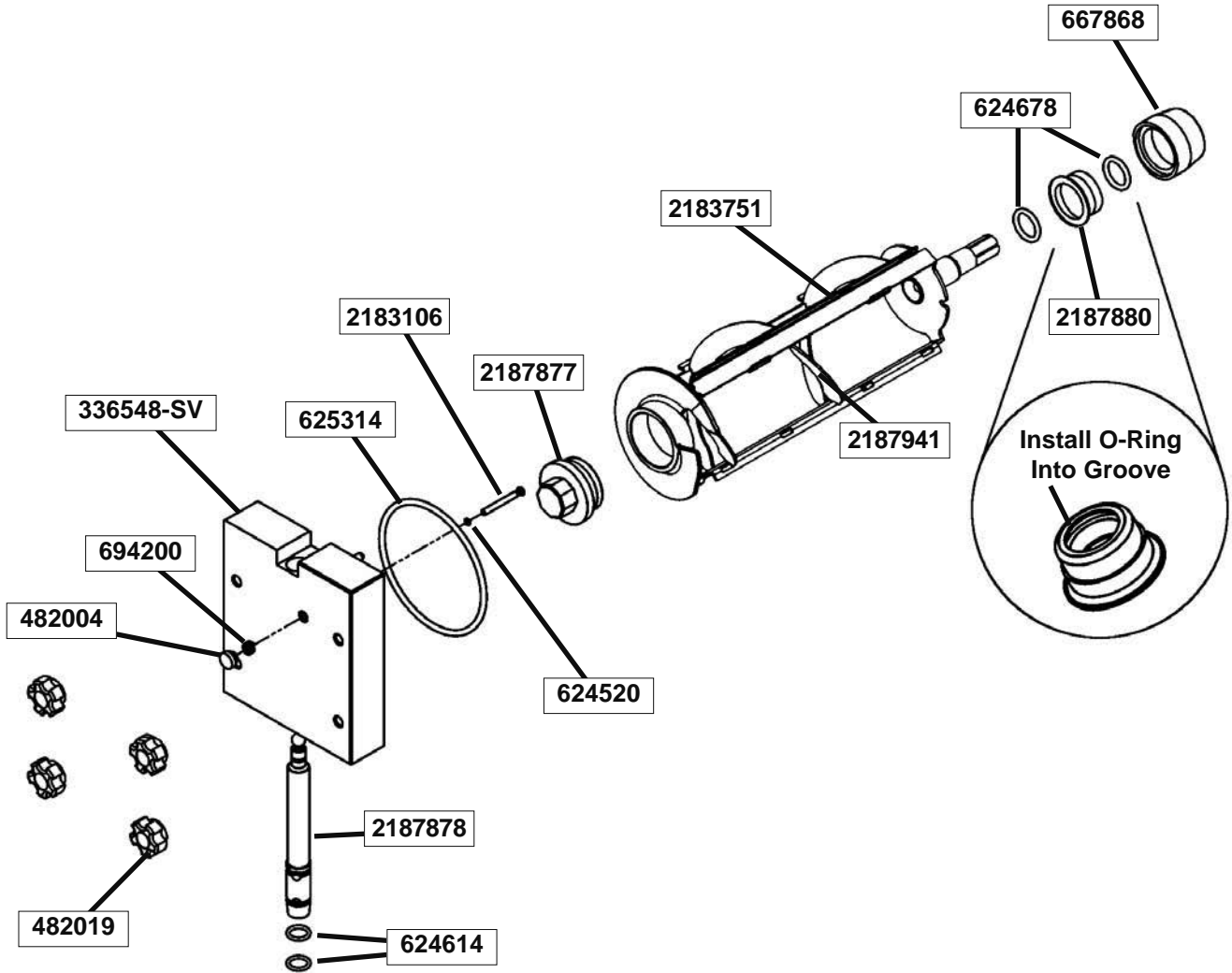

Part Number	Description	Quantity
336548-SV	Front Door	1
482004	Knob (Air Bleed Valve)	1
482019	Knob - Front Door (Black)	1
624520	O-Ring - Air Bleed Valve - Black	2
624614	O-Ring - Spigot - Black	2
624678	O-Ring - Rear Seal - Black	2
625314	O-Ring - Front Door - Black	1
667868	Seal - Rear Auger (Orange)	1
694200	Spring - Air Bleed Valve	1
2183106	Valve - Air Bleed	1
2183751	Scraper Blade	3
2187877	Bushing - Front Auger Support	1
2187880	Adapter - Rear Seal	1
2187878	Spigot Body	1
2187941	Auger Shaft	1

6.4 BLENDER PARTS AND DRIP TRAY

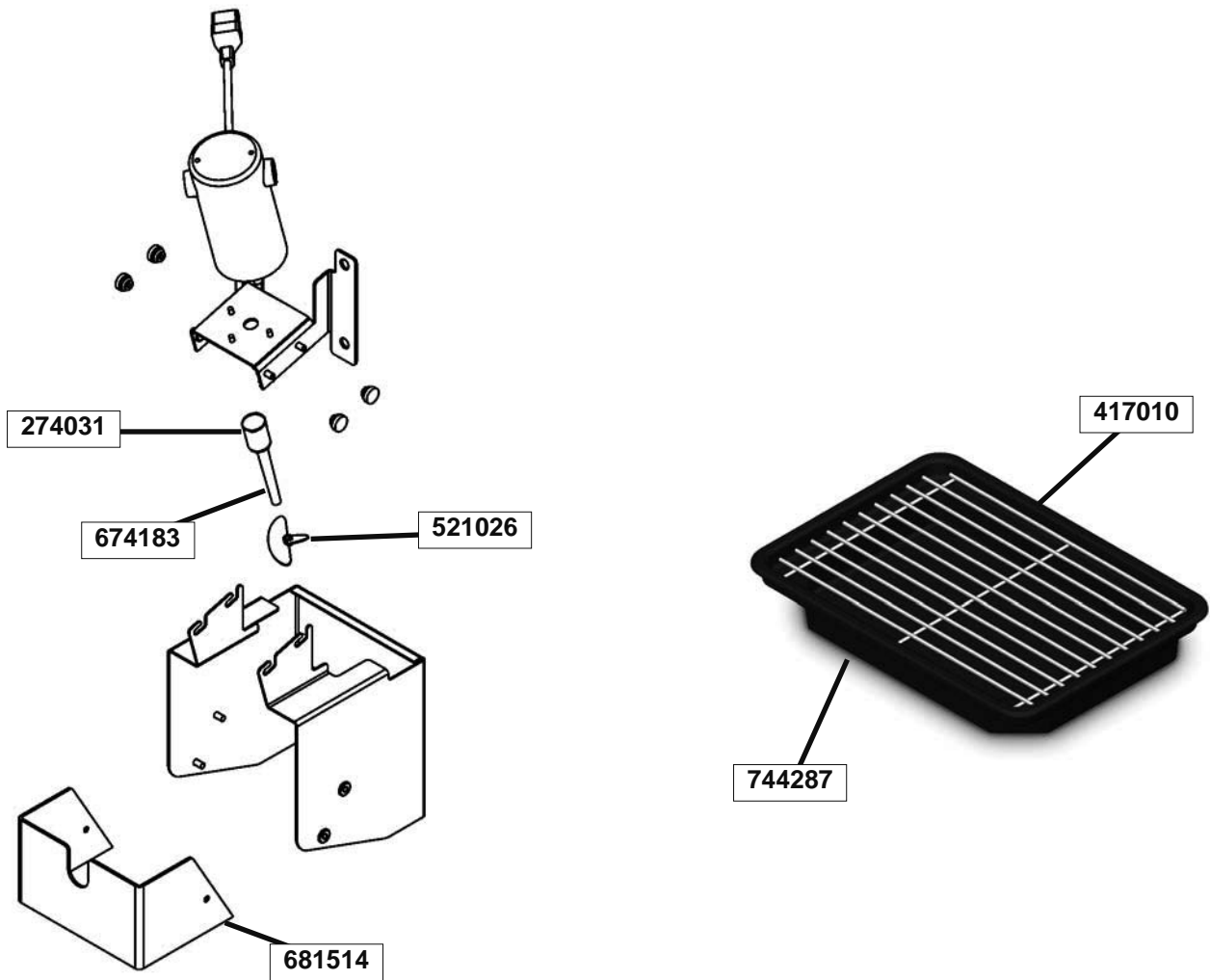

Part Number	Description	Quantity
274031	Blender Agitator Collar	1
417010	Grid - Drip Tray (Metal)	1
521026	Blender Agitator	1
674183	Blender Shaft	1
681518	Swing Shield (Plastic)	1
744262	Tray - Drain (Shake)	1
744276	Tray - Drain (Soft Serve)	1
744287	Tray - Drip	1

6.5 CAB TUBING

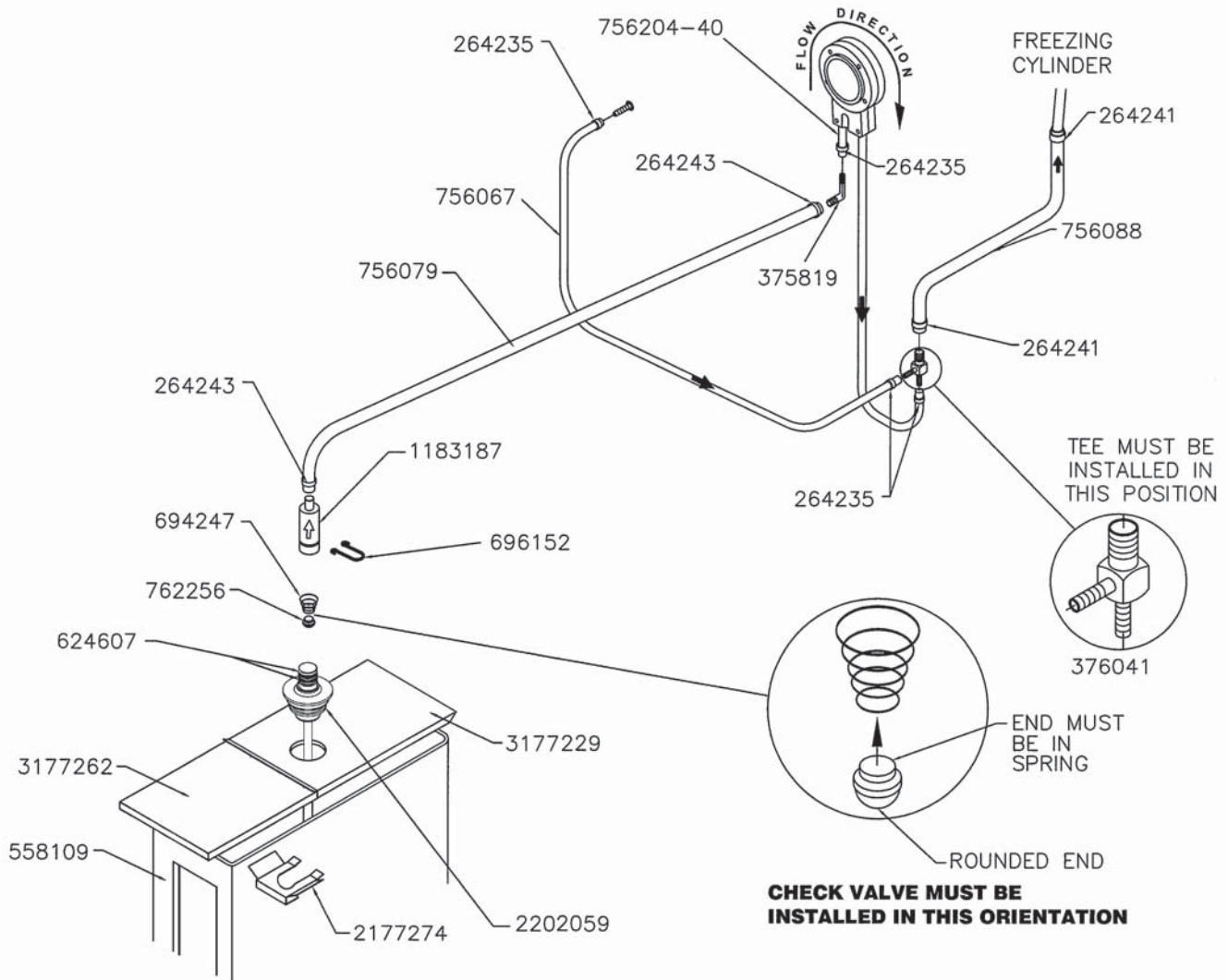

Part Number	Description	Quantity
264235	Clamp - Metal (1/4" ID Tubing) (Cab)	8
264241	Clamp - Metal (1/2" ID Tubing) (Cab)	4
264243	Clamp - Metal (3/8" ID Tubing) (Cab)	8
375819	Elbow - Barbed (3/8" - 1/4") (Cab)	2
376041	Tee Connector - 3-Way (Stainless) (Cab)	2
558109	Mix Container Only (Cab)	2
624607	O-Ring - Check Valve Body - Black (Cab)	4
694247	Spring - Cone (Spigot Cam) (Soft Serve) & (Cab Check Valve)	2
696152	Clip - Lock (Check Valve) (Cab)	6
756067	Tubing - 1/4" ID - Clear - Air Line (25' Increments) (Per Inch)	Two 13"
756079	Tubing - 3/8" ID - Clear - Mix Line (25' Increments) (Per Inch)	Two 24"
756088	Tubing - 1/2" ID - Clear - Mix Line (25' Increments) (Per Inch)	Two 6"
756204	Tubing - 1/4" ID - Pump (50' Box Only) (Per Inch) (Cab)	-
756204-40	Tubing - 1/4" ID - Pump (Pre-Cut 40" Piece) (Cab)	8
762256	Check Valve - Mix Outlet (Cab)	2
1183187	Check Valve - Mix In Line (Outer) (Cab)	2
2177274	Clip - Retaining (Mix Probe To Cover) (Cab)	2
2187307	Pick-Up Tube - Mix (Cab)	2
3177229	Cover - Rear (Mix Container) (Cab)	2
3177262	Cover - Front (Mix Container) (Cab)	2



WARRANTY SOFT SERVE / SHAKE FREEZERS

1. Scope:

Stoelting, LLC warrants to the first user (the "Buyer") that the freezer cylinders, hoppers, compressors, drive motors, speed reducers, augers and auger flights of Stoelting soft serve / shake freezers will be free from defects in materials and workmanship under normal use and proper maintenance appearing within five (5) years, and that all other components of such equipment manufactured by Stoelting will be free from defects in material and workmanship under normal use and proper maintenance appearing within twelve (12) months after the date that such equipment is originally installed.

2. Disclaimer of Other Warranties:

THIS WARRANTY IS EXCLUSIVE; AND STOELTING HEREBY DISCLAIMS ANY IMPLIED WARRANTY OF MERCHANTABILITY OR FITNESS FOR PARTICULAR PURPOSE.

3. Remedies:

Stoelting's sole obligations, and Buyer's sole remedies, for any breach of this warranty shall be the repair or (at Stoelting's option) replacement of the affected component at Stoelting's plant in Kiel, Wisconsin, or (again, at Stoelting's option) refund of the purchase price of the affected equipment, and, during the first twelve (12) months of the warranty period, deinstallation/reinstallation of the affected component from/into the equipment. Those obligations/remedies are subject to the conditions that Buyer (a) signs and returns to Stoelting, upon installation, the Checklist/Warranty Registration Card for the affected equipment, (b) gives Stoelting prompt written notice of any claimed breach of warranty within the applicable warranty period, and (c) delivers the affected equipment to Stoelting or its designated service location, in its original packaging/crating, also within that period. Buyer shall bear the cost and risk of shipping to and from Stoelting's plant or designated service location.

4. Exclusions and Limitations:

This warranty does not extend to parts, sometimes called "wear parts", which are generally expected to deteriorate and to require replacement as equipment is used, including as examples but not intended to be limited to o-rings, auger seals, auger support bushings and drive belts. All such parts are sold

AS IS.

Further, Stoelting shall not be responsible to provide any remedy under this warranty with respect to any component that fails by reason of negligence, abnormal use, misuse or abuse, use with parts or equipment not manufactured or supplied by Stoelting, or damage in transit.

THE REMEDIES SET FORTH IN THIS WARRANTY SHALL BE THE SOLE LIABILITY STOELTING AND THE EXCLUSIVE REMEDY OF BUYER WITH RESPECT TO EQUIPMENT SUPPLIED BY STOELTING; AND IN NO EVENT SHALL STOELTING BE LIABLE FOR ANY INCIDENTAL OR CONSEQUENTIAL DAMAGES, WHETHER FOR BREACH OF WARRANTY OR OTHER CONTRACT BREACH, NEGLIGENCE OR OTHER TORT, OR ON ANY STRICT LIABILITY THEORY.

January 30, 2003
721-013, Rev. 0