



FOODSERVICE EQUIPMENT
Model U421/U444

(Serial #17978 and up)

OWNER'S MANUAL

Manual No. 513595-4 Feb. 2009 Rev. 4

Need Parts or Service?



We stock the parts you need.
Our Technicians are factory trained and are certified in the Stoelting Technicare program.



CALL
Distributor: _____
Phone No.: _____
(fill in or affix label)

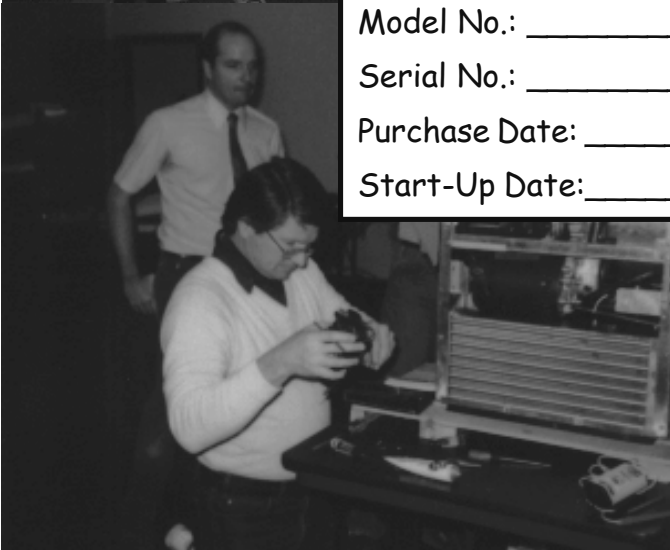

Model No.: _____
Serial No.: _____
Purchase Date: _____
Start-Up Date: _____



STOELTING® OWNER'S MANUAL
FOR
MODEL U421/U444
CAB MODEL SOFT-SERVE PRESSURIZED FREEZER

This manual provides basic information about the freezer. Instructions and suggestions are given covering its basic operation and care.

The illustrations and specifications are not binding in detail. We reserve the right to make changes at any time without notice, to the freezer and its components, without incurring any obligation to modify or provide new parts for freezers built prior to date of change.

DO NOT ATTEMPT to operate the freezer until instructions and safety precautions in this manual are read completely and are thoroughly understood. If problems develop or questions arise in connection with installation, operation or servicing of the freezer, contact the company at the location listed below.

STOELTING, LLC
502 Hwy 67
Kiel, WI 53042-1600

Tele: 920-894-2293

Fax: 920-894-7029

TABLE OF CONTENTS

Section 1	1
1.1 Description	1
1.2 Specifications	2
Section 2	3
2.1 Safety Precautions	3
2.2 Shipment & Transit	4
2.3 Freezer Installation	4
2.4 Installing Permanent Wiring	4
2.5 Mix Pump	5
Section 3	9
3.1 Safety Precautions	9
3.2 Operating Controls and Indicators	9
3.3 Important Information Regarding Cleaning and Sanitizing	11
3.4 Disassembly of Freezer Parts	12
3.5 Cleaning Disassembled Parts	13
3.6 Sanitize Freezer Parts	13
3.7 Cleaning the Freezer	14
3.8 Assembling the Freezer	14
3.9 Sanitizing	16
3.10 Initial Freeze down and Operation	16
3.11 Mix Information	17
3.12 Operation of Mix Pump	18
3.13 Mix Pump Cleaning	18
3.14 Disassembly and Inspection of Removable Parts	18
Section 4	21
4.1 Freezer Adjustment	21
4.2 Product Temperature Adjustment	21
4.3 Overrun Adjustment	21
4.4 Mix Pump Hose Reposition	22
4.5 Mix Pump Hose Replacement	22
4.6 Cab Temp. Adjustment	22
4.7 Drive Belt Tension Adjustment	22
4.8 Condenser Cleaning (Air Cooled Freezers)	23
4.9 Preventative Maintenance	23
4.10 Extended Storage	23
4.11 Troubleshooting	24
Section 5	29
5.1 How to Order Replacement Parts	29
5.2 Parts Lists and Reference Drawings	29

ILLUSTRATIONS

Figure 1	Model U421/U444 Series Freezer	1
Figure 2a	Air-Cooled Specifications	2
Figure 2b	Water-Cooled Specifications	2
Figure 3	Decal Locations	3
Figure 4	Water/Electrical Connections	4
Figure 5	Auger Rotation	5
Figure 6	Mix Hose Installation	5
Figure 7	Mix Pump	6
Figure 8	3-way Tee	7
Figure 9	Mix Inlet Tube & Probe Assy. Clip	7
Figure 10	Hose Holder	7
Figure 11	Operating Controls	9
Figure 12	Auger Flight Wear & Front Auger Support Bushing Wear	12
Figure 13	Front Door Disassembly	13
Figure 14	Auger Flight Removal	13
Figure 15	Rear Seal Removal	13
Figure 16	Rear Seal Lubrication	14
Figure 17	Spring Installation	14
Figure 18	Front Door Assembly	15
Figure 19	Air Bleed Valves	16
Figure 20	Draining Sanitizer	16
Figure 21	Refrigerated Cabinet	17
Figure 22	Mix Pumps	18
Figure 23	Removable Parts	19
Figure 24	Cleaning Air Tube	19
Figure 25	Cleaning Feed Tube	19
Figure 26	Mix Pump Tube Routing	19
Figure 27	Potentiometer	21
Figure 28	Overrun Adjustment	21
Figure 29	Temperature Control Cab	22
Figure 30	Belt Adjustment	23

A Few Words About Safety

Safety Information

Read and understand the entire manual before operating or maintaining Stoelting equipment.

This Owner's Manual provides the operator with information for the safe operation and maintenance of Stoelting equipment. As with any machine, there are hazards associated with their operation. For this reason safety is emphasized throughout the manual. To highlight specific safety information, the following safety definitions are provided to assist the reader.

The purpose of safety symbols is to attract your attention to possible dangers. The safety symbols, and their explanations, deserve your careful attention and understanding. The safety warnings do not by themselves eliminate any danger. The instructions or warnings they give are not substitutes for proper accident prevention measures.

If you need to replace a part, use genuine Stoelting parts with the correct part number or an equivalent part. We strongly recommend that you do not use replacement parts of inferior quality.



Safety Alert Symbol:

This symbol Indicates danger, warning or caution. Attention is required in order to avoid serious personal injury. The message that follows the symbol contains important information about safety.

Signal Word:

Signal words are distinctive words used throughout this manual that alert the reader to the existence and relative degree of a hazard.



The signal word "WARNING" indicates a potentially hazardous situation, which, if not avoided, may result in death or serious injury and equipment/property damage.



The signal word "CAUTION" indicates a potentially hazardous situation, which, if not avoided, may result in minor or moderate injury and equipment/property damage.

CAUTION

The signal word "CAUTION" not preceded by the safety alert symbol indicates a potentially hazardous situation, which, if not avoided, may result in equipment/property damage.

NOTICE

The signal word "NOTICE" indicates information or procedures that relate directly or indirectly to the safety or personnel or equipment/property.

SECTION 1 INTRODUCTION

1.1 DESCRIPTION

The Stoelting U421 and U444 floor model freezers are pressure fed. The freezers are equipped with fully automatic controls to provide a uniform product. The U421 freezer is designed to operate with almost any type of commercial soft serve. The U444 freezer is designed to dispense soft

serve product from the left side and shake product from the right side.

This manual is designed to assist qualified personnel and operators in the installation, operation and maintenance of the Stoelting Model U421 and U444 pressure freezer.



Figure 1a. Model U421 Series Freezer

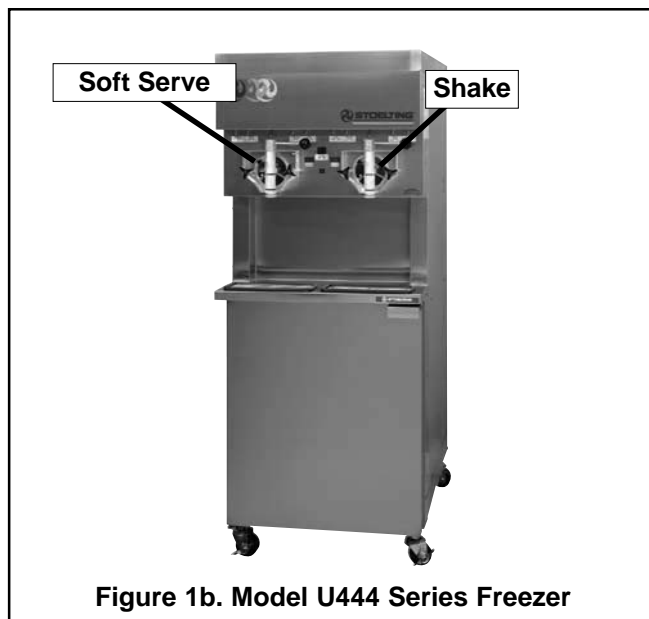

Figure 1b. Model U444 Series Freezer

1.2 SPECIFICATIONS

Dimensions	U421/U431/U444 Water Cooled				U421/U431/U444 Air Cooled			
	Freezer		with crate		Freezer		with crate	
width	26-3/4" (67,9 cm)		34" (86,4 cm)		26-3/4" (67,9 cm)		34" (86,4 cm)	
height	65-3/4" (167,0 cm)		78" (198,1 cm)		67-3/4" (172,1 cm)		78" (198,1 cm)	
depth	39-3/4" (101,0 cm)		48" (121,9 cm)		39-3/4" (101,0 cm)		48" (121,9 cm)	
Weight	760 lbs (344,7 kg)		908 lbs (411,8 kg)		785 lbs (356,0 kg)		935 lbs (424,1 kg)	
Electrical	1 PH		3 PH		1 PH		3 PH	
	left	right	left	right	left	right	left	right
minimum circuit ampacity	31A	31A	21A	21A	36A	31A	26A	21A
maximum overcurrent protection device	45A	45A	30A	30A	50A	45A	35A	30A
International Option	1 Phase, 220-240 VAC, 50Hz or 3 Phase, 380-415 VAC, 50Hz							
Compressor	Two - 18,000 Btu/hr							
Drive Motor	Two - 2 hp							
Cooling	Water cooled units require 1/2" N.P.T. water and drain fittings.				Air cooled units require 3" (7,6 cm) air space on right, 10" (25,4 cm) above.			
Hopper Volume	Two - 8 gallon (30,28 liters)							
Freezing Cylinder Volume	Two - 1.33 gallon (5.32 quart), 5,4 liters							
Production Capacity	Soft Serve - 18 GPH (68,14 liters) Shake - 27 GPH (102,21 liters)							

AIR-COOLED MODEL

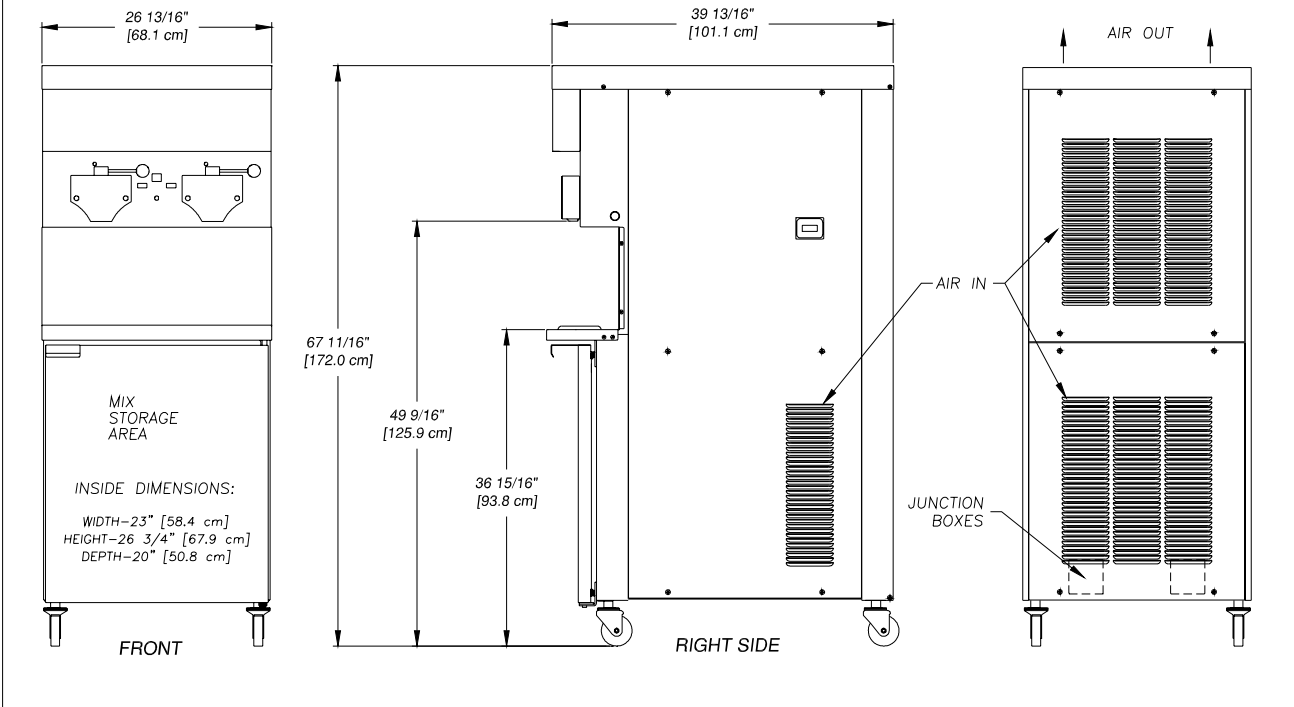

Figure 2a. Air-Cooled Specification

WATER-COOLED MODEL

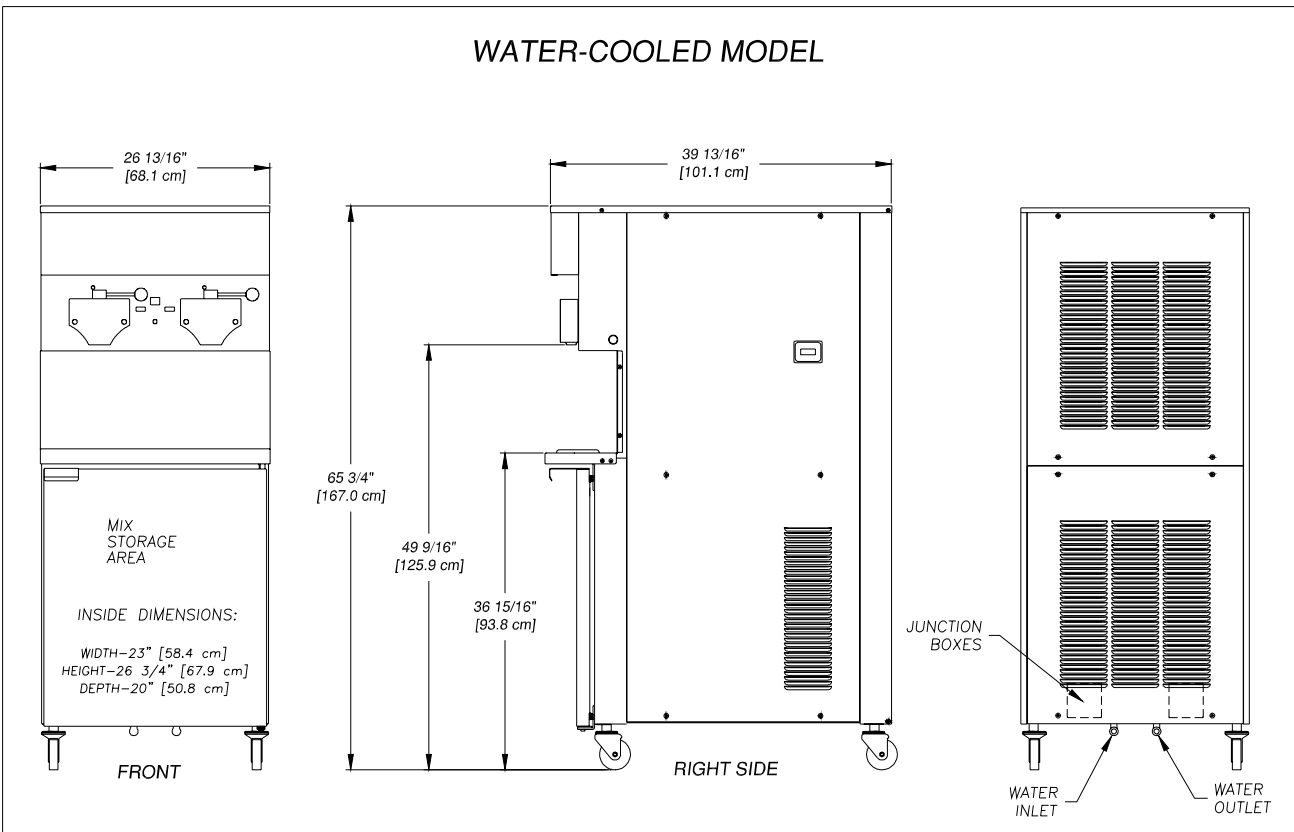

Figure 2b. Water Cooled Specification

SECTION 2 INSTALLATION INSTRUCTIONS

2.1 SAFETY PRECAUTIONS

Do not attempt to operate the freezer until the safety precautions and operating instructions in this manual are read completely and are thoroughly understood.

If danger, warning or caution labels are needed, indicate the part number, type of label, location of label, and quantity required along with your address and mail to:

Take notice of all warning labels on the freezer. The labels have been put there to help maintain a safe working environment. The labels have been designed to withstand washing and cleaning. All labels must remain legible for the life of the freezer. Labels should be checked periodically to be sure they can be recognized as warning labels.

STOELTING, LLC
ATTENTION: Customer Service
502 Hwy. 67
Kiel, Wisconsin 53042

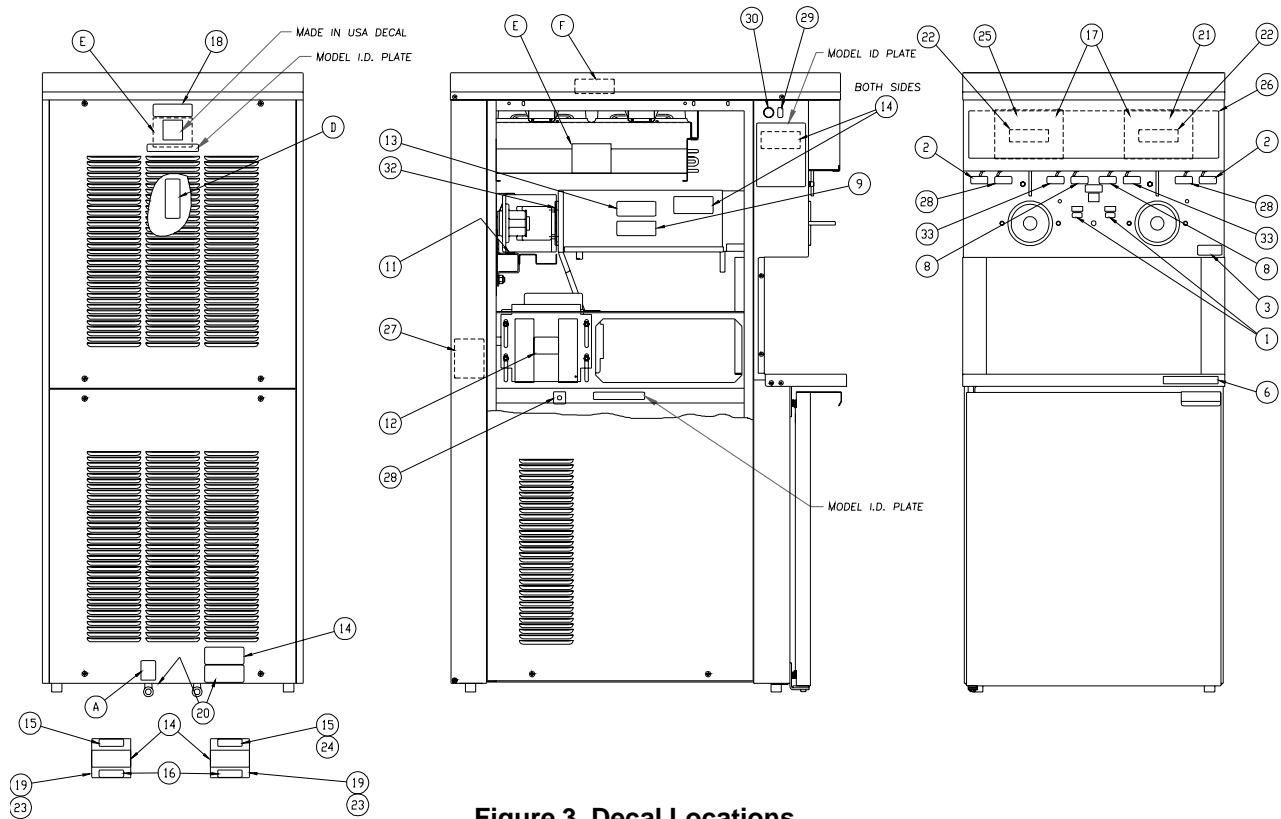

Figure 3. Decal Locations

1	324722	Decal Mix Low	23	324015	Decal 2 x 1-1/4 Blk on White
2	324798	Decal Clean-Off-Serve Switch	24	723552	Tag, Caution - Supply Voltage
3	324141	Decal Caution - Rotating Blades	26	324803	Decal GM Header (Stoelting Logo)
4	723526	Tag Read Manual & All Decals	26	324804	Decal GM Header (Stoelting Swirl)
6	324393	Decal Stoelting Swirl Logo	26	324805	Decal DQ Header (DQ Logo)
7	324800	Decal Cab ON/OFF	27	324346	Decal Caution Hazard.Moving
8	324799	Pump On/Off	28	324797	Decal Standby/Serve
9	324208	Decal Refrig. Leak Check	29	324242	Decal Temperature Control
11	324103	Decal Caution - Rotating Shaft	30	324200	Decal Manual Reset
12	324686	Decal Danger Automatic Start	32	324014	Decal Arrow
13	324107	Decal Caution Moving Parts	33	324496	Decal Freezing
14	324125	Decal Elect.Shock Hazard			Water Cooled Only
15	324151	Decal Field Connections	A	324065	Decal Water Inlet
16	324198	Decal Attention Installer	B	723525	Tag Winterizing Disconnect Line
17	130000	Bag, Envelope Front Loading	C	723517	Tag, W/C Tower Instructions
18	324584	Decal Adequate Ventilation	D	324107	Decal Caution Moving Parts
19	324158	Decal Copper Conductors Only			Air Cooled Only
20	324106	Decal Caution Wiring Mat'l	E	324346	Decal Hazardous Moving Parts
22	324566	Decal Wired According To	F	324107	Decal Caution Moving Parts

2.2 SHIPMENT AND TRANSIT

The freezer has been assembled, operated, and inspected at the factory. Upon arrival at the final destination, the freezer must be checked for any damage which may have occurred during final transit.

With the method of packaging used, the equipment should arrive in excellent condition. **THE CARRIER IS RESPONSIBLE FOR ALL DAMAGE IN TRANSIT, WHETHER VISIBLE OR CONCEALED. Do not** pay the freight bill until the freezer has been checked for damage. Have the carrier note any visible damage on the freight bill. If concealed damage and/or shortage is found later advise the carrier within ten days and request inspection. The customer must place claim for damage and/or shortages in shipment with the carrier. **Stoelting, LLC. cannot make any claims against the carrier.**

2.3 FREEZER INSTALLATION

WARNING

Installation must be performed by a qualified electrician/refrigeration specialist. Incorrect installation may cause personal injury, severe damage to the machine and will void factory warranties.

WARNING

Lifting hazard

Do not attempt to lift freezer manually. Use proper lifting equipment such as a forklift, lift table, or pallet jack, with lifting device positioned beneath the freezer's base. Ensure that personnel remain clear of suspended load. Failure to do so may result in personal injury and/or damage to the freezer that will void any factory warranties.

Installation of the freezer involves moving the freezer close to its permanent location, removing all crating, setting in place, assembling parts, and cleaning.

- A. Uncrate the freezer.
- B. Install the four casters. Turn the threaded end into the freezer until zero threads are showing. To level, turn out casters no more than 1/4" maximum, then tighten all jam nuts.
- C. The freezer must be placed in a solid level position.

NOTE

Accurate leveling is necessary for correct drainage of freezer barrel and to insure correct overrun.

- D. The freezer must have a minimum of 3" (7,5cm) -6" (15cm) high ambient conditions- of space on all sides and 10" (25cm) at the top for proper circulation.

CAUTION

Risk of product damage

Air cooled condenser requires proper ventilation. Failure to provide adequate ventilation will void factory warranties.

- E. Water-cooled freezers need an adequate water supply. Install 1/2" (12,7mm) pipe or 1/2" (12,7mm) inside diameter copper water line to the freezer. Connect water outlet to a drain using a 1/2" (12,7mm) inside diameter line. Automatic washer hoses work well for final connections. All water connections must comply with local codes. Fig. 4.



Figure 4. Water/Electrical Connections

CAUTION

Flush all water lines before installation. In stores with sediment in water, add suitable filter or strainer to water inlet.

- F. Place the CLEAN-OFF-SERVE switches in the OFF position before continuing. Figure 11.

2.4 INSTALLING PERMANENT WIRING

Permanent wiring is required by local codes, the following procedure must be performed:

WARNING

Hazardous voltage

High voltage will shock, burn or cause death. Turn off and lock out main power disconnect before installing wiring. Do not operate machine with cabinet panels removed.

- A. Refer to the nameplate at the rear of the freezer for specific electrical requirements. Make sure the power source in the building matches the freezer nameplate requirements. Bring the wires into the junction boxes through the access holes in the bottom rear of the freezer. Figure 4.

NOTICE

Three phase freezers in areas of unbalanced electrical loads require special attention when connecting input electrical power. The unbalanced leg of power (called wild or high) must be connected to L2 in the junction box.

NOTICE

Verify actual voltage. Machine is equipped with a transformer to supply a control circuit. You will need to check voltage on terminal C1 and C2 on EACH control board. (Located behind decorative header panel on front of machine.) Transformers are located behind electrical panel enclosing control boards. Access these by removing top panel of machine. Actual transformer voltage should read 20-28 V.A.C.

- B. Remove the lower back panel and the two junction box covers located at the bottom of the freezer.
- C. Install permanent wiring according to local code.
- D. Check the auger shaft rotation by placing the MAIN DRIVE switch in the CLEAN position.

Auger shaft rotation is clockwise as viewed through the clear plastic front door. If the rotation is not clockwise, turn main electrical power OFF. Then reverse L1 and L3 electrical power lines to the junction box (three phase only). Re-check auger shaft rotation. Figure 5.



Figure 5. Auger Rotation

2.5 MIX PUMP

- A. Mix Pump Hose Installation
 - Follow the steps below to install the mix pump hose.
 - 1. Turn pump on.
 - 2. Feed one end of mix pump hose into the entering or pick-up hose side (left) of black cover.
 - 3. Gently push the hose into the black cover until it begins to feed.
 - 4. Allow the hose to feed itself thru the pump until 6" (15cm) remains on the entering side.

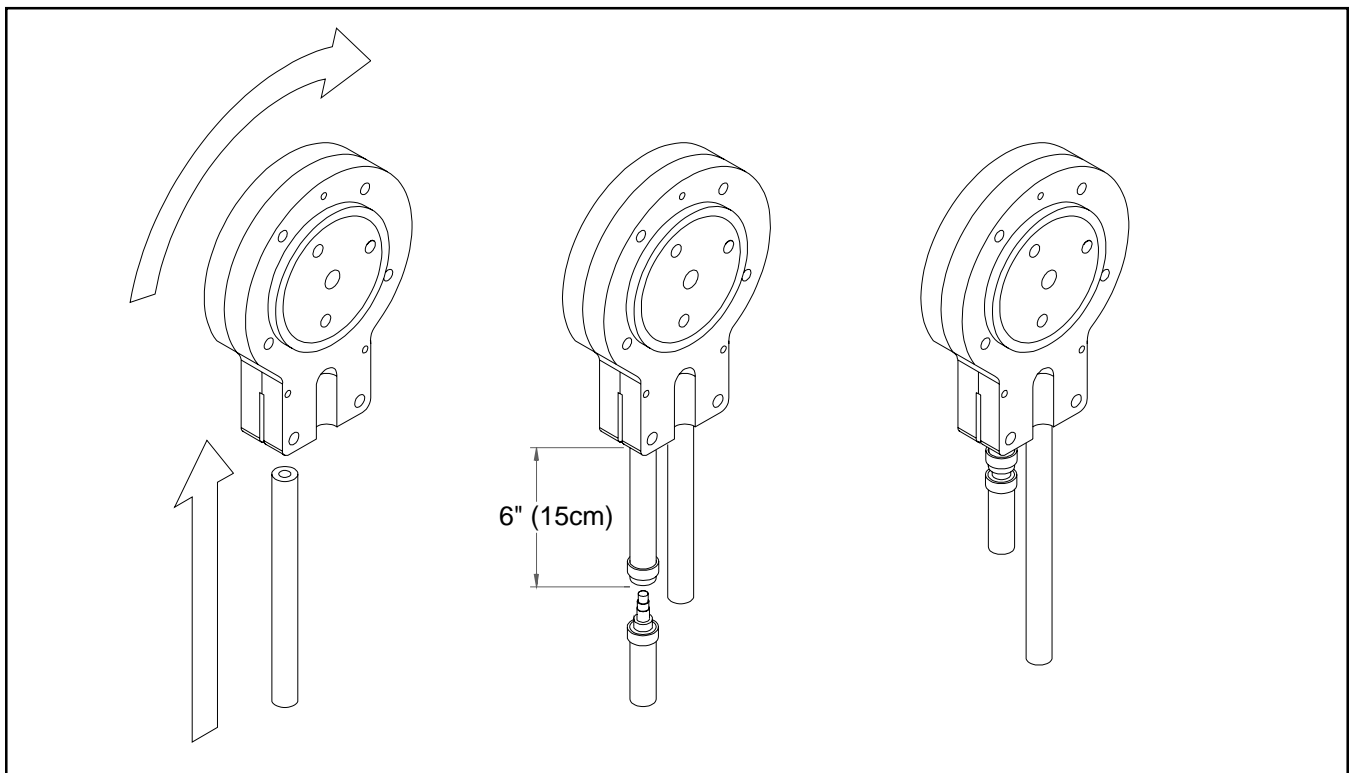

Figure 6. Mix Hose Installation

5. Turn pump off.
6. Connect mix pump hose to pickup hose adapter using small hose clamp.

CAUTION
DO NOT TWIST MIX PUMP HOSE.

7. Turn pump off.
8. Allow remaining 6" (15cm) of tubing to feed through pump until hose adapter prevents further feeding.
9. Turn pump off.
10. Connect free end of mix pump hose to 3-way Tee

- B. Connect 1/2 inch (12,7mm) I.D. plastic food grade tubing to check valve and then to the mix container. Observe check valve flow arrow. Secure with hose clamps. Then place assembly thru hole in cover and install retainer clip. Figure 9.
- C. Connect 1/2 inch (12,7mm) I.D. plastic food grade tubing between the large port of air/mix tee and refrigerated mix transfer line. Secure with large hose clamp or equivalent. Figure 9.

CAUTION
Air/Mix tee must remain below the black cover/clamp. If the tee is above the pump mix will drain to the air compressor resulting in pump damage.

- D. Connect mix low cords.

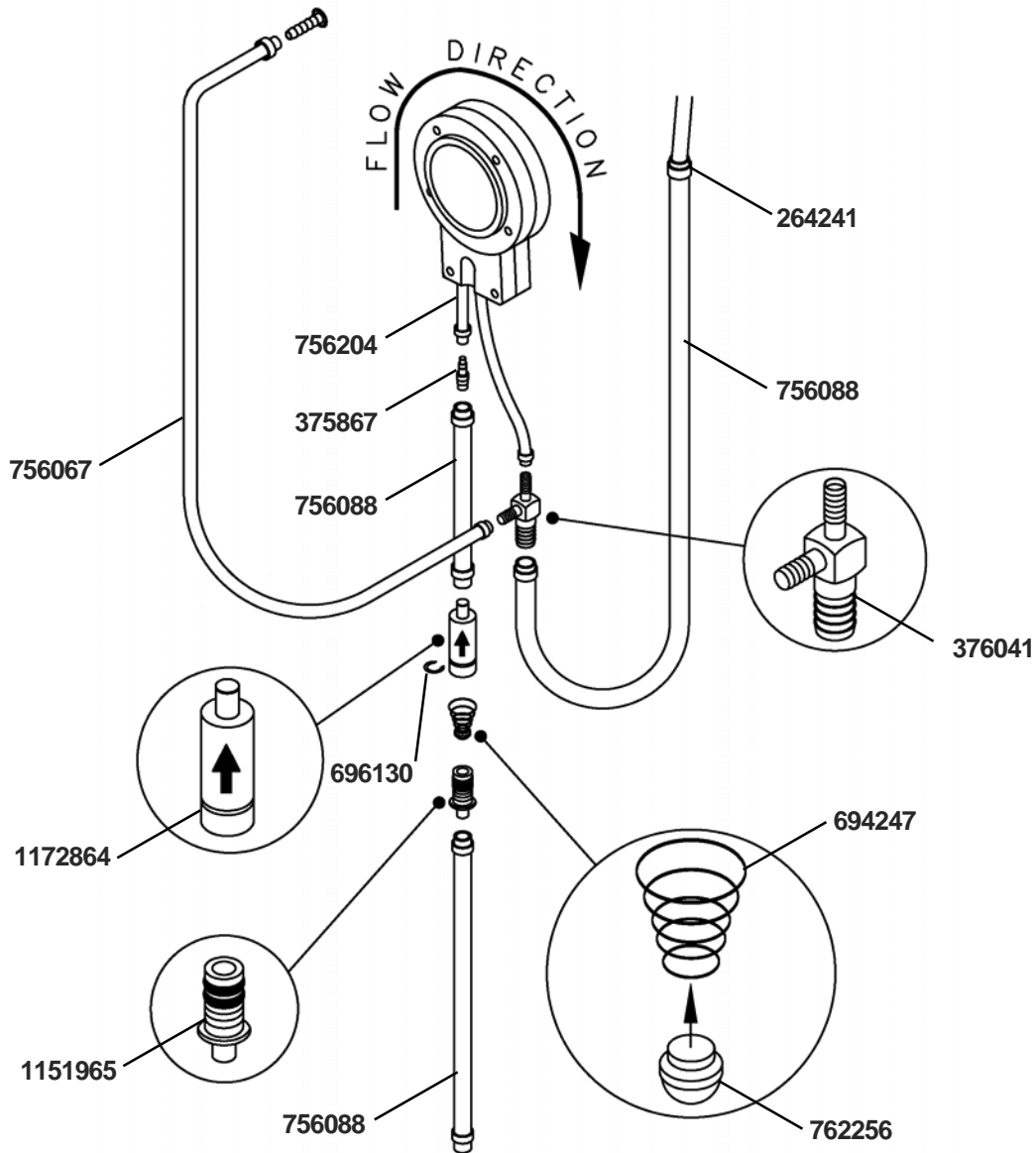

Figure 7. Mix Pump



Figure 8. 3-way Tee

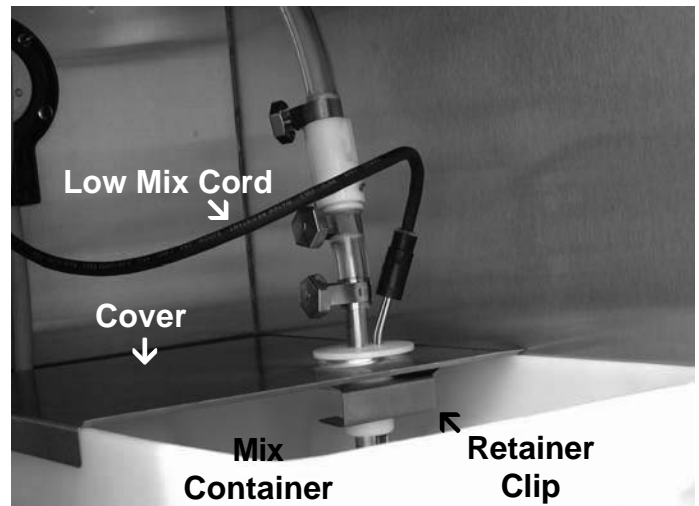

Figure 9. Mix Inlet Tube & Probe Assy. Clip



Figure 10. Hose Holder

SECTION 3 INITIAL SET-UP AND OPERATION

3.1 SAFETY PRECAUTIONS

SAFE OPERATION IS NO ACCIDENT; observe these rules:

- A. **Know the freezer.** Read and understand the operating instructions.
- B. **Notice all warning labels on the freezer.**
- C. **Wear proper clothing.** Avoid loose fitting garments, and remove watches, rings or jewelry which could cause a serious accident.
- D. **Maintain a clean work area.** Avoid accidents by cleaning the area and keeping it clean.
- E. **Stay alert at all times.** Know which switch, push button or control you are about to use and what effect it is going to have.
- F. **Disconnect electrical power for maintenance.** Never attempt to repair or perform maintenance on the freezer until the main electrical power has been disconnected.
- G. **Do not operate under unsafe operating conditions.** Never operate this freezer if unusual or excessive noise or vibration occurs.

3.2 OPERATING CONTROLS AND INDICATORS

Before operating the freezer, it is required that the operator know the function of each operating control. Refer to Fig.11 for the location of the operating controls on the freezer.

 <b style="font-size: 1.2em;">WARNING
<p>Hazardous voltage The CLEAN-OFF-ON switch must be placed in the OFF position when disassembling for cleaning or servicing. The freezer must be disconnected from electrical supply before removing any access panel. Failure to disconnect power before servicing could result in death or serious injury.</p>

- A. **Spigot Switch**
When the spigot handle is opened the SPIGOT switch will start the auger drive and refrigeration systems. When the spigot handle is closed, the drive motor and compressor will remain on until the product in the barrel reaches the proper temperature.
- B. **Clean-Off-Serve Switch**
The CLEAN-OFF-SERVE switch is a three position toggle switch used to control the operation of the refrigeration system and auger. When the switch is placed in the CLEAN position, the refrigeration system will be off and auger **will** rotate for cleaning.



Figure 11. Operating Controls

When the switch is placed in the OFF position, the refrigeration system and auger **will not** operate.

When the switch is placed in the SERVE position, the refrigeration system and auger **will** operate automatically. The switch should be placed in the SERVE position for normal operation.

C. Cabinet-Off-On Switch

The CABINET-OFF-ON switch is a two position toggle switch. When the switch is placed in the OFF position, the lower cabinet refrigeration system **will not** run. When the switch is placed in the ON position, the lower cabinet refrigeration system **will** run until the preset temperature is reached; then cycle ON and OFF to maintain that temperature.

D. Cab Indicator Light

A flashing light indicates the cab OFF-ON switch is in the OFF position, no refrigeration. Place the OFF-ON switch in the ON position for cab refrigeration.

E. Pump Switch

The pump motor switch is a two position toggle switch. When the switch is placed in the OFF position, the pump **will not** run. When the switch is placed in the ON position, the pump **will** run until the preset pressure is reached, then cycle ON and OFF as product is drawn to maintain that pressure.

F. Standby/Serve Switch

The standby/serve switch is a two position toggle switch. When the switch is placed in the standby position the freezer will cycle to maintain a temperature below 41°F (-15°C). When the switch is in the Serve position the freezer will cycle to maintain a servable product.

G. Freezing Switch

The freezing switch is a two position toggle switch. When the switch is placed in the MAXIMUM position the freezer will be forced to run 30 seconds after the temperature control is satisfied.

H. High Head Pressure Cut Out

If the head pressure exceeds 445 psig (28 bar) air cooled and water cooled, the high head pressure cutout will trip. The reset button can be accessed from the side of the freezer.

I. Low Mix Light

The low mix light will illuminate when the liquid level in the mix container drops below two gallons.

J. Front Door Safety Switch

The front door safety switch prevents the auger from turning when the front door is removed. The switch is open when the door is removed and closed when the door is properly installed.

3.3 IMPORTANT INFORMATION REGARDING CLEANING AND SANITIZING

Soft serve and shake freezers require special consideration when it comes to food safety and proper cleaning and sanitizing.

The following information specifically covers issues for cleaning and sanitizing frozen dessert freezers. This information is meant to *supplement* a comprehensive food safety program.

Soil Materials Associated with Frozen Dessert Machines

MILKFAT/BUTTERFAT – As components of ice-cream/frozen custard mix, these soils will accumulate on the interior surfaces of the machine and its parts. Fats are difficult to remove and help attribute to milkstone build-up.

MILKSTONE – Is a white/gray film that forms on equipment and utensils that come in contact with dairy products. These films will accumulate slowly on surfaces because of ineffective cleaning, use of hard water, or both. **Milkstone is usually a porous deposit, which will harbor microbial contaminants and eventually defy sanitizing efforts.**

Once milkstone has formed, it is very difficult to remove. Without using the correct product and procedure, it is nearly impossible to remove a thick layer of milkstone.
(NOTE: general-purpose cleaners DO NOT remove milkstone.) **This can lead to high bacteria counts and a food safety dilemma.**

IT IS BEST TO CONTROL MILKSTONE ON A DAILY BASIS BEFORE IT CAN BECOME A SIGNIFICANT FOOD SAFETY PROBLEM.

In addition to food safety, milkstone can cause premature wear to machine parts which can add to costs for replacement parts or possibly more expensive repairs if worn machine parts are not replaced once they have become excessively worn.

Important Differences Between *Cleaning* and *Sanitizing*

CLEANING vs. SANITIZING

It is important to distinguish between cleaning and sanitizing. Although these terms may sound synonymous, they are not. BOTH are required for adequate food safety and proper machine maintenance.

CLEANING

- Is the removal of soil materials from a surface.
- Is a prerequisite for effective sanitizing.

NOTE

An UNCLEAN surface will harbor bacteria that can defy sanitizing efforts.

Bacteria can develop and resist sanitizing efforts within a layer of soil material (milkstone). **Thorough cleaning procedures that involve milkstone removal are critical for operators of frozen dessert machines.**

SANITIZING

- Kills bacteria.
- Can be effective on clean surfaces only.
- **DOES NOT** clean or remove milkstone.

NOTE

Using a SANTITIZER on an unclean surface will not guarantee a clean and safe frozen dessert machine.

Proper Daily Maintenance: The Only Way to Assure Food Safety and Product Quality

Proper daily maintenance can involve a wide variety of products and procedures. Overall, the products and procedures fall into three separate categories. *(Please note that this is a brief overview intended for informational purposes only.)*

1. **CLEANING** – This involves draining mix from the freezer barrel and rinsing the machine with water. Next, a cleaner is run through the machine. Then, the machine is disassembled and removable parts are taken to the sink for cleaning.
2. **MILKSTONE REMOVAL** – Since almost all cleaners do not have the ability to remove milkstone, the use of a delimer becomes necessary. Although this procedure may not be needed on a daily basis, it will usually follow the cleaning procedure. It requires letting a delimer solution soak in the machine for an extended period of time. Individual parts are also soaked in a deliming solution for an extended period of time (more about delimers in *Additional Information*).
3. **SANITIZING** – After the machine has been cleaned and contains no milkstone, the machine is reassembled. Then a FDA-approved sanitizing solution is run through the machine to kill bacteria. The machine is then ready for food preparation.

As a recommended cleaner and sanitizer for your frozen dessert machine, STERA-SHEEN has proven to be one of the best daily maintenance products for:

- **CLEANING** – Thorough removal of all solids including butterfat and milk fat.
- **MILKSTONE REMOVAL** – Complete removal of milkstone.
- **SANITIZING** – FDA-approved no rinse sanitizer for food contact surfaces.

Additional Information

THE USE OF DELIMERS

A delimer is a strong acid that has the ability to dissolve milkstone. This type of chemical may become necessary once high levels of milkstone have developed. While these products are very effective for removing HIGH levels of milkstone, they are not ideal for two reasons:

1. **PRODUCT SAFETY** – Strong acids are dangerous chemicals and handling them requires safety
2. **MACHINE DAMAGE** – Strong acids will attack metal and rubber causing premature wear of parts. The use of a delimer needs to be closely monitored to avoid damage to machine surfaces and parts.

With proper daily use of STERA-SHEEN or it's equivalent, there is *no need* for the use of a *DELIMER*.

DO NOT USE BLEACH

- BLEACH HAS ABSOLUTELY **NO** CLEANING PROPERTIES.
- BLEACH IS CORROSIVE. It can and will damage components of the machine causing premature wear and metal corrosion.

GENERAL PURPOSE CLEANERS

General purpose cleaners **do not** have the ability to remove milkstone. Milkstone will become a problem *if not remedied* with additional products and procedures.

THE USE OF CHLORINE TEST STRIPS

“Test strips” are used to determine concentrations of active chlorine in sanitizing solutions. To use the strips, tear off a small portion and submerge it into the sanitizing solution. Then, compare the color change to the color key on the side of the test strip dispenser to determine the approximate chlorine concentration.

The ideal concentration of chlorine needs to be 100 ppm (as stated by the FDA).

NOTE

Follow the directions on the container for proper concentration.

There are two main factors that contribute to falling chlorine concentrations in a sanitizing solution.

1. **PRODUCT USE** – As the chlorine in the solution is being used, chlorine concentrations fall.
2. **TIME** – As time passes, small amounts of chlorine “evaporate” from the solution. (That is why you can smell it.)

Sanitizing solutions *should not* be allowed to fall below 100 ppm chlorine. New solutions should be mixed once old solutions become ineffective.

3.4 DISASSEMBLY OF FREEZER PARTS

WARNING

Moving machinery can grab, mangle and dismember. Place the CLEAN-OFF-SERVE toggle switch in the OFF position before disassembling for cleaning or servicing. Placing the CLEAN-OFF-SERVE toggle switch in the SERVE position during cleaning or servicing may result in serious personal injury.

Before using the freezer for the first time, complete freezer disassembly, cleaning and sanitizing procedures will need to be followed. Routine cleaning intervals and procedures must comply with the local and state health codes. Inspection for worn or broken parts should be made at every disassembly of the freezer for cleaning or other purposes. All worn or broken parts should be replaced to ensure safety to both the operator and the customer and to maintain good freezer performance and a quality product. Two normal wear areas are the auger flights and front auger support bushing (see Figure 12).

To disassemble the freezer, refer to the following steps:



Figure 12. Auger Flight Wear & Front Auger Support Bushing Wear

A. Disassembly Of Front Door

1. Remove the front door by turning off the black knobs and then pulling the front door off the studs.
2. Remove the air bleed valve by unscrewing the knob while holding the valve stem from behind. Remove the compression spring and push air bleed valve through the rear of the front door.
3. Remove the spigot through the bottom of the front door (see Figure 13). Remove all O-rings from spigot and air bleed valve.



Figure 13. Front Door Disassembly

B. Disassembly Of Auger

1. Remove the front auger support by pulling it straight out of the freezer barrel.
2. Remove the plastic bearing from the front auger support.
3. Remove the auger by pulling slowly and rotating out of the freezer barrel. As the auger is withdrawn, remove each plastic flight and spring from the auger. Be careful not to scratch inside of freezer barrel when removing flights or auger. Remove the spring from each auger flight.



Figure 14. Auger Flight Removal

4. Keep the rear of the auger tipped up once it is clear of the freezer barrel.
5. Wipe spline lubricant off hex end of auger with a paper towel. Remove the rear seal. Figure 15.



Figure 15. Rear Seal Removal

3.5 CLEANING DISASSEMBLED PARTS

Disassembled freezer parts require complete cleaning, sanitizing and air drying before assembling. Local and state health codes will dictate the procedure required. Some state health codes require a four sink process (pre-wash, wash, rinse, sanitize, air dry), while others require a three sink process (without the pre-wash step). The following procedures are a general guideline only. Consult your local and state health codes for procedures required in your location.

- A. To clean the freezer parts, disassemble all parts. (Refer to section 3.4 for the disassembly of freezer parts.)
- B. Place all front door and auger parts in clean 90° to 110°F (32°C to 43°C) water and wash thoroughly (four sink procedure only).
- C. Place all parts in 90° to 110°F (32°C to 43°C), mild detergent water and wash thoroughly.
- D. Rinse all parts with clean 90° to 110°F (32°C to 43°C) water.
- F. Sanitize all freezer parts following procedures outlined below.

3.6 SANITIZE FREEZER PARTS

- A. Use a sanitizer mixed according to manufacturer's instructions to provide a 100 parts per million strength solution. Mix sanitizer in quantities of no less than 2 gallons of 90° to 110°F (32°C to 43°C) water. Allow the sanitizer to contact the surfaces to be sanitized for 5 minutes. Any sanitizer must be used only in accordance with the manufacturer's instructions.
- B. Place all parts in the sanitizing solution for 5 minutes, then remove and let air dry completely before assembling in freezer.

3.7 CLEANING THE FREEZER

CAUTION

Risk of Product Damage

Do not use acid cleaners, strong caustic compounds or abrasive materials to clean any part of the freezer exterior or plastic parts.

The exterior should be kept clean at all times to preserve the lustre of the stainless steel. A good grade of stainless steel has been used on the freezer to ease clean-up. To remove spilled or dried mix, simply wash the exterior in 90° to 110°F (32°C to 43°C), soapy water and wipe dry.

Do not use highly abrasive materials as they will mar the finish. A mild alkaline cleaner is recommended. Use a soft cloth or sponge to apply the cleaner. For best results, wipe in the direction of the grain of the steel.

- A. Clean the rear seal surface from inside of the freezer barrel.
- B. Using this sanitizing solution and the large barrel brush provided, sanitize the barrel by dipping the brush in the sanitizing solution and brushing the inside of the barrel.
- C. Remove the rear drip tray by pulling from side panel. Clean and replace drip tray.

3.8 ASSEMBLING FREEZER

To assemble the freezer parts, refer to the following steps:

NOTICE

Petro-Gel sanitary lubricant or equivalent must be used when lubrication of freezer parts is specified.

NOTICE

The United States Department of Agriculture and the Food and Drug Administration require that lubricants used on food processing equipment be certified for this use. Use Lubricants only in accordance with the manufacturer's instructions.

- A. Assemble all O-rings onto parts dry, **without lubrication**. Then apply a thin film of sanitary lubrication to exposed surfaces of the O-rings.
- B. Lubricate rear seal area on auger shaft with a thin layer of sanitary lubricant. Install the rear seal O-ring. Lubricate outside of rear seal O-ring with sanitary lubricant.
- C. Install stainless steel rear seal adapter into rear seal dry (without lubricant). Lubricate inside surface of rear seal adapter and install onto auger shaft. **DO NOT** lubricate outside of rear auger seal (see Figure 16).

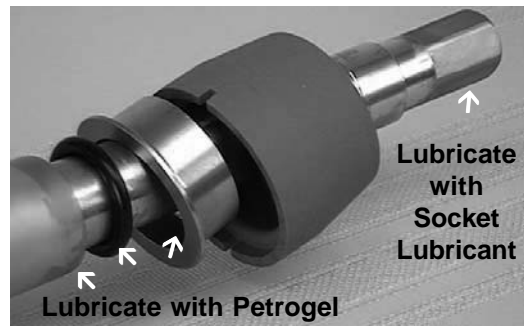

Figure 16. Rear Seal Lubrication

- C. Lubricate the hex drive end of auger with a small amount of white socket lubricant. A small container of socket lubricant is shipped with the freezer.
- D. Screw the springs onto the studs in plastic flights. **Spring must be screwed into the flights completely** to provide proper tension (see Figure 17).



Figure 17. Spring Installation

- E. Install first flights to bottom of auger, rotate, add successive flights from bottom as the auger is pushed slowly into the freezer barrel. Carefully engage auger with drive socket in speed reducer by rotating auger slowly and pushing on end of auger.
- F. Apply a thin film of sanitary lubricant to the inside and outside of the front auger support bearing, then place on the front of the auger. Assemble the front auger support onto the auger bearing.

NOTICE

Position the front support on auger so legs do not interfere with the pin on the back of the front door assembly. Front door must push auger in slightly when it is being tightened to prevent the rear seal from leaking.

- G. Assemble O-rings onto the spigot dry, without lubrication. Then apply a thin film of sanitary lubricant to the outside of the O-rings and spigot bodies.
- H. Install the spigot through the bottom of the front door (see Figure 18).



Figure 18. Front Door Assembly

- I. Assemble the air bleed valve O-ring onto the air bleed valves. Position the O-ring in groove close to the wide part. Apply a thin film of sanitary lubricant to the O-rings.
- J. Insert the air bleed valve from the back of the front door. Install compression springs onto air bleed valves, then screw knobs on finger tight.
- K. Apply a thin film of sanitary lubricant to the door seal O-rings, and fit into the grooves on the rear of the front door.
- L. Place the front door assembly on the mounting studs and push front door against the freezer carefully.
- M. Secure front door assembly by placing the knobs on the studs and tighten until **finger tight only**. Do **not** overtighten. Proper O-ring seal can be observed through the transparent front door.
- N. Move the spigot handles to the closed position.

3.9 SANITIZING

Sanitizing must be done after the freezer is clean and just before the freezer is filled with mix. **Sanitizing the night before is not effective.** However, you should always clean the freezer and parts after using it.

WARNING

The United States Department of Agriculture and the Food and Drug Administration require that all cleaning and sanitizing solutions used with food processing equipment be certified for this use.

When sanitizing the freezer, refer to local sanitary regulations for applicable codes and recommended sanitizing products and procedures. The frequency of sanitizing must comply with local health regulations. Mix sanitizer according to manufacturer's instructions to provide a 100 parts per million strength solution. Mix sanitizer in quantities of no less than 2 gallons of 90°F to 110°F 90° to 110°F (32°C to 43°C) water. Allow sanitizer to contact the surfaces to be sanitized for 5 minutes. Any sanitizer must be used only in accordance with the manufacturer's instructions.

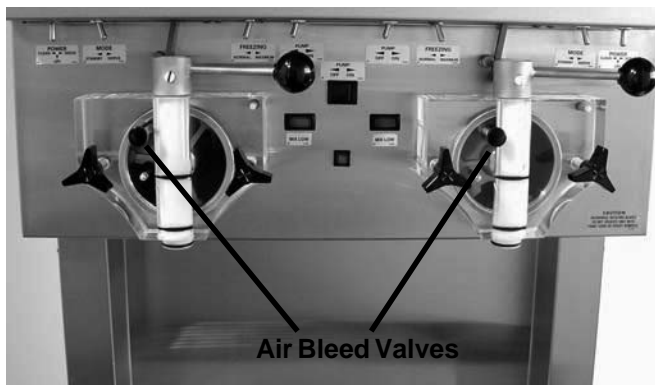

Figure 19. Air Bleed Valves

CAUTION

Risk of Product Damage

Avoid prolonged contact of sanitizer with freezer parts. Prolonged contact of sanitizer with freezer may cause corrosion of stainless steel parts.

- A. Prepare 3 gallons of sanitizing solution following manufacturer's instructions, and pour into storage container.
- B. Place the mix pump switch in the ON position and open air bleed valve on the front door by pushing valve in and holding (see Figure 19).

- C. Let sanitizing solution fill the freezer barrel to air bleed valve, then close the valve by pulling out to lock in place.
- D. Place the CLEAN-OFF-SERVE toggle switch in the CLEAN position.



Figure 20. Draining Sanitizer

- E. Check for leaks when the freezer barrel is first pressurized with sanitizing solution.
 - 1. Check for leaks at the plastic front door, the O-rings may not be sealed.
 - 2. Check the drain located at the center of the Drip Tray for leaks coming from the rear of the Rear Auger Seal.
 - 3. Check inside cab unit for leaks at hose connections.
- F. Using a sanitized soft bristle brush or equivalent, dipped in sanitizing solution, clean mix container.
- G. After five minutes, open spigot to expel sanitizing solution. Drain all solution from freezer using both spigots (See Figure 20).
- H. Close the spigot and place the mix pump switch and the CLEAN-OFF-SERVE switch in the OFF position.

The freezer is now sanitized and ready for adding mix.

3.10 INITIAL FREEZE DOWN AND OPERATION

This section covers the recommended operating procedures to be followed for the safe operation of the freezer.

- A. Sanitize just prior to use according to instructions outlined in this manual.
- B. Prepare the desired amount of mix and then fill each storage container with approximately 3 gallons or more of mix. Place a container(s) of mix in the refrigerated cabinet. If drawing from a storage container, place the draw tube through the cover to the bottom of the container. If drawing from a bag in a box, remove the cap, push out all of the air, and insert the adaptor.

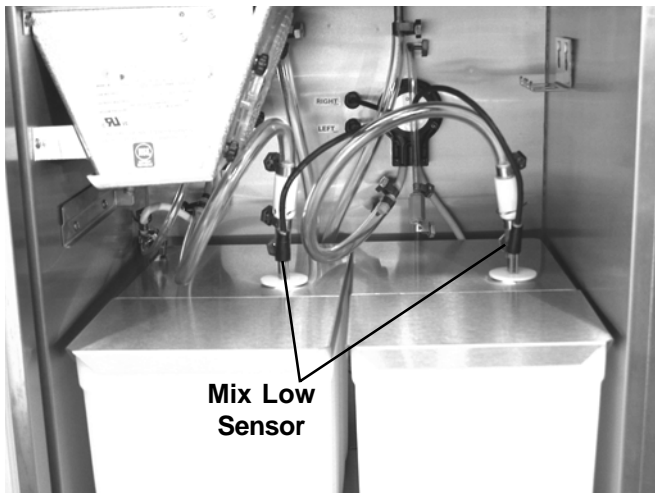

Figure 21. Refrigerated Cabinet

- C. Place the mix pump switch in the ON position. Immediately open the spigot and let approximately 8 ounces of liquid mix with sanitizing solution drain out of the spigot.
- D. Close the spigot and open the air bleed valve on the front door by pushing the valve in and holding. Allow the barrel to fill until the mix level is 1/2" (2.7 cm) below air bleed valve, then release valve and pull closed to lock in place.
- E. Start the compressor and drive by placing the CLEAN-OFF-SERVE switch in the SERVE position
- F. The product will be ready to serve after the compressor and drive have cycled off, or in approximately 12 minutes.
- G. The refrigeration is automatically actuated when the spigot is opened. For normal dispensing, open the spigot no more than 90°. (This is when the handle knob is pointed directly away from the front door.) This position provides excellent control over the product and aids in making desired shaped portions. Close spigot completely after dispensing.

The freezer is designed to dispense the product at a reasonable draw rate. If the freezer is overdrawn, the result will be a soft product and air pops. If this should occur, allow the freezer to run for approximately 30 seconds before dispensing additional product. After a while the operator will sense or feel when the freezer is beginning to fall behind, and will slow down on the rate of draw so as not to exceed the freezer's capacity.

Do not operate the freezer when the MIX LOW light is on or with less than 1-3/4" (4.4 cm) of mix in the mix container. Refill the mix container immediately.

3.11 MIX INFORMATION

Mix can vary considerably from one manufacturer to another. Differences in the amount of butter-fat content and quantity and quality of other ingredients have a direct bearing on the finished frozen product. A change in freezer performance that cannot be explained by a technical problem may be related to the mix.

Proper product serving temperature varies from one manufacturer's mix to another. Soft serve mixes should provide a satisfactory product in the 17° to 20°F (-7° to -6°C) range. Most shake mixes freeze to proper consistency at 27°F (-2.8°C). Diet and low-carb mixes typically freeze to proper consistency at higher temperatures.

When checking the temperature, stir the thermometer in the frozen product to read the true temperature.

Mix does not improve with age. Old mix, or mix that has been stored at too high a temperature, can result in a finished product that is less than satisfactory from the appearance and taste standpoint. To retard bacteria growth in dairy based mixes, the best storage temperature range is between 36° to 40°F (2.2° to 4.4° C).

3.12 OPERATION OF MIX PUMP

The pump switch is located on the front of the freezer. When the pump switch is placed in the ON position, the mix pump motor will be actuated to pump mix into the freezer cylinder. When the set pressure is reached, the mix pump will shut off automatically. When the switch is placed in the OFF position, the mix pump will be inoperative.

NOTE

The mix pump motor is equipped with an internal overload that will “trip”, disabling the pump when the motor is overloaded. Consult the trouble shooting section for corrective information. The internal overload will automatically reset after cooling. If the condition continues, contact a qualified service person.

CAUTION

Risk of Product Damage

Mix pump hose must be repositioned every 1 -2 weeks or 60 hours of operation. Failure to comply will result in reduced mix pump liquid capacity, dispense stoppage, popping, and possible mix pump hose leakage. Hose leakage may damage the pump roller assembly and void the factory warranty.

- A. Mix Operation: The peristaltic mix pump contains one continuous mix pump hose. When looking at the face of the peristaltic mix pump, the left side of the hose is the suction or pickup. The right side of the hose is the discharge. Mix is drawn up the suction side of the hose and transferred thru the discharge side to the freezer (see Figure 22).
- B. Air Operation: The air compressor operates whenever the peristaltic mix pump is running. Air enters thru a check valve on the piston downstroke. The air is discharged thru a second check valve, on the piston upstroke. The air and mix join at the tee and then travel to the freezer.

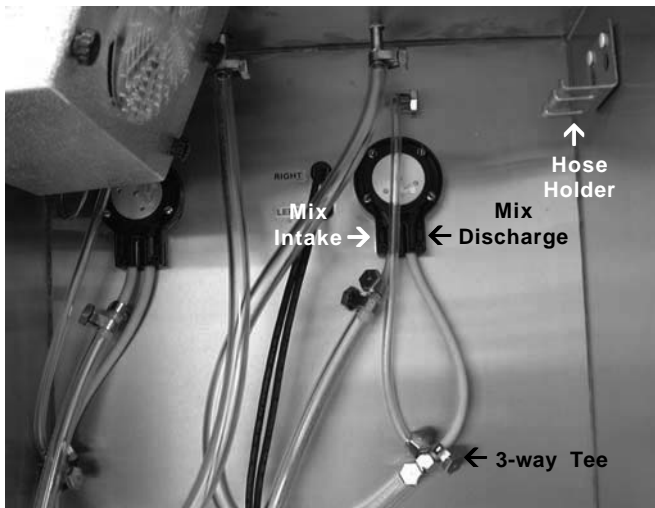

Figure 22. Mix Pumps

- C. The over-run adjustment is preset at the factory. If an adjustment becomes necessary, refer to Section 4.

NOTICE

Any cleaning procedure must always be followed by sanitizing before filling freezer with mix. (Refer to section 3.3)

3.13 MIX PUMP CLEANING

The mix pump is approved for CIP (clean in place) and is thoroughly cleaned as cleaning solutions are pumped thru the freezer. We recommend completely disassembling the pump and connecting tubing every 14 days for inspection of parts to confirm the CIP has been properly performed. If any residue is detected clean or replace those parts as outlined below.

1. Place CLEAN-OFF-SERVE switch in CLEAN position. Allow the auger to agitate for 5 to 10 minutes.
2. Remove suction tube from mix container. Draw off the mix remaining in freezer barrel.
3. Pump 2 gallons (7.5 liters) of cold potable water thru freezer until water at spigot is free of mix.
4. Pump 2 gallons (7.5 liters) of 90° to 110°F (32°C to 43°C) detergent solution water thru freezer. The use of soft water is recommended, along with dishwashing detergents such as “Joy,” “Dawn,” or equivalent.
5. Place mix pump switch in OFF position. Open spigot to relieve remaining pressure.
6. Place CLEAN-OFF-SERVE switch in OFF position.

3.14 DISASSEMBLY AND INSPECTION OF REMOVABLE PARTS

Inspection of removable parts should be made whenever maintenance is performed or pump requires disassembly.



WARNING

Hazardous Moving Parts

Revolving pump head can grab, mangle, and cause serious crushing injury. The Power switch must be placed in the OFF position for cleaning and power must be disconnected when disassembling or servicing.



CAUTION

System Under Pressure

Never disconnect hoses from freezer or pump without first opening spigot to relieve pressure.

NOTE

If the mix lines or air line is difficult to remove, soften with a rag soaked in hot water. Hose connections may be sprayed with Haynes Sanitary Lubricant for ease of removal. Do not loosen or remove the mix pump cover wingnuts. Maintain the mix pump hose in its operational condition.

1. Loosen clamp and remove air hose from pump compressor.
2. Loosen clamp and disconnect mix pump hose. Remove the pickup hose, mix check valve and pickup hose adapter (and bag adapter if applicable) as an assembly from mix container.
3. Completely disassemble both hose assemblies and check valve. Place hoses, tee, check valve assembly, and pickup hose adapter in 90° to 110°F (32°C to 43°C), mild detergent water and wash thoroughly. Use soft bristle brushes to clean inside of fittings. Rinse all parts in clean 90° to 110°F (32°C to 43°C) water (see Figure 23).
4. Carefully inspect each part for wear or damage. Replace worn or damaged parts.
5. Wash feed tube and air tube with 90° to 110°F detergent water and brushes provided. Rinse with clean, 90° to 110°F water (See Figure 24 and 25).
6. Prepare two gallons (7.5 liters) of sanitizing solution using a USDA certified grade sanitizing solution. Sanitize all removed parts, then air dry.
7. Check Hose Service Record decal to determine if hose reposition or replacement is required at this time.
8. Reassemble both hose assemblies per the diagram located on the inside of the cab door. Reconnect assemblies to the pump and discharge hose, using the clamps. (See Figure 26 or refer to Section 2.5 Mix Pump).

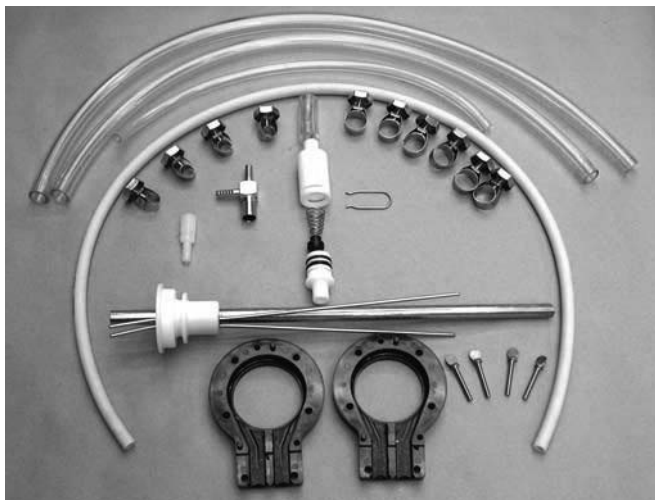

Figure 23. Removable Parts

9. Sanitize assembled freezer as per instructions outlined in Section 3.9).



Figure 24. Cleaning Air Tube



Figure 25. Cleaning Feed Tube

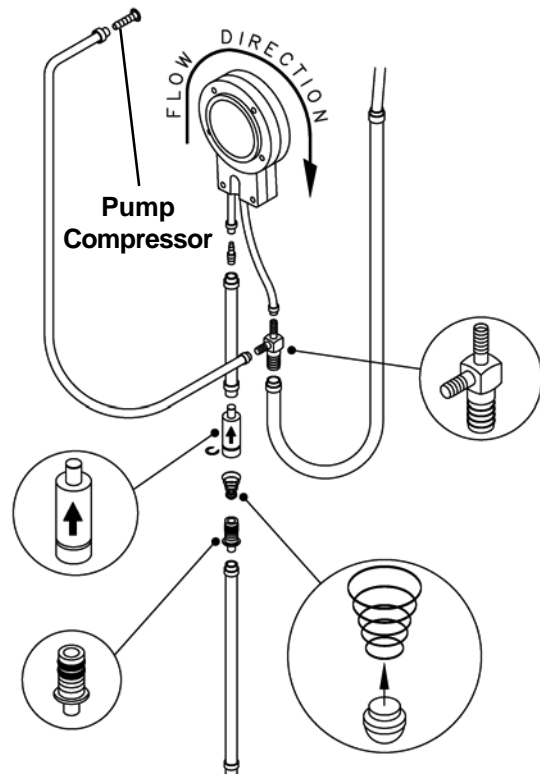

Figure 26. Mix Pump Tube Routing

SECTION 4 MAINTENANCE INSTRUCTIONS

4.1 FREEZER ADJUSTMENT

This section is intended to provide maintenance personnel with a general understanding of the freezer adjustments. It is recommended that any adjustments in this section be made by a qualified person.

4.2 PRODUCT TEMPERATURE ADJUSTMENT

A potentiometer is used to control the product temperature. To change the temperature of the product, follow the steps below:

- A. Loosen the two screws under the header display sign, then pull sign out and down.
- B. Use a screw driver to make desired adjustment. A label near the potentiometer will give complete instructions (see Figure 26).



Figure 27. Potentiometer

4.3 OVERRUN ADJUSTMENT

The product when served is a combination of air and mix. Overrun is a measure of the amount of air blended into the mix.

Overrun can be expressed in terms of the amount of weight loss for a given volume. For example, if a pint of liquid mix weighs 18 ounces (510 grams) and a pint of frozen product with air added weighs 12 ounces (340 grams), the overrun is said to be 50 percent "18 oz. (510 grams) - 12 oz. (340 grams) = 6 oz. (170 grams)", $(6/12) \times 100 = 50\%$.

The overrun can be checked by placing a one pint container on an ice cream scale and zeroing out the scale. Then fill a one pint container with frozen product. The container should be filled over the top and leveled with a straightedge. The product should not contain any air pockets. When weighed on an ice cream scale, one pint (473 milliliters) of product should weigh 12 to 13 ounces (340 to 368,5 grams) for an overrun of 45 to 50%.

The mix pump that fills the left freezing cylinder of the U444 has been preset at the factory to produce a soft serve product with approximately 40% overrun. The mix pump that fills the right freezing cylinder of the U444 has been preset at the factory to produce a shake product with approximately 50% overrun. The left and right pumps on the U421 have been preset to produce a soft serve product with approximately 40% overrun. Because of differences in mix formulation, temperatures and barometric pressure, this figure may vary. It will be necessary for approximately 2 gallons (7,5 liters) of mix to be pumped thru the freezer before changes in the product are noticeable due to adjustments in overrun.

Overrun is controlled by the length of the air compressor piston stroke within the piston cylinder. Lengthening the stroke within the cylinder will increase overrun. Conversely, shortening the stroke will decrease overrun. To perform an overrun adjustment, refer to the following procedure:

- A. Turn the mix pump switch to the OFF position .
- B. Remove the lower back panel from freezer.
- C. On air compressor side of pump, locate the long/slender piston rocking arm. The rocking arm downward travel is limited by a stationery cam. On the face of the cam there is an overrun setting indicator plate numbered 3 thru 8 and an adjustment knob (see Figure 27).

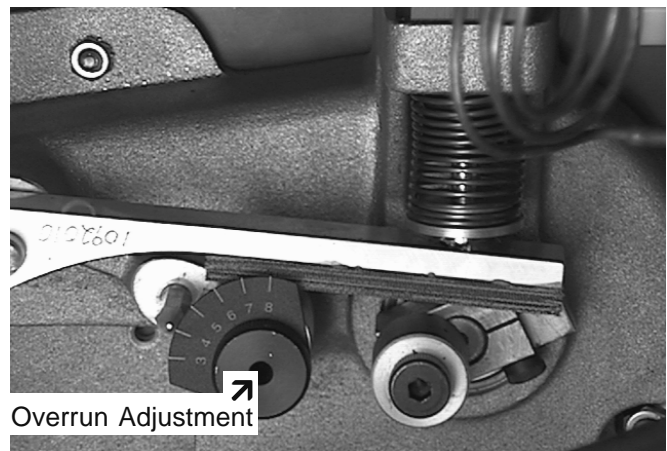

Figure 28. Overrun Adjustment

- D. The overrun setting is indicated by a pointed pin.
- E. To adjust overrun, loosen the allenhead screw (located within the center of the adjustment knob) with the 5/32" (4mm) allen wrench provided. Rotate the adjustment knob counterclockwise to a higher number for higher overrun, or clockwise to a lower number for lower overrun. Each number multiplied by 10 represents the overrun percentage (ie: #4 = 40% overrun).

- F. Tighten the allen screw, then place the wrench back in its clip. Replace the lower back panel and secure with the four screws. Turn the mix pump power switch to the ON position.

4.4. MIX PUMP HOSE REPOSITION (every one or two weeks.)

NOTICE

Mix pump hose must be repositioned every 1 - 2 weeks. Failure to comply will result in reduced mix pump liquid capacity, dispense stoppage, popping, and possible mix pump hose leakage.

1. Run cleaning solution through pump.
2. Turn pump off and relieve any pressure by opening the spigot.
3. Grasp the pick-up hose end of the mix pump hose with one hand and turn the pump on. Pull down on the pick-up hose end until 12 to 14" (30-1/2 to 35-1/2cm) of tubing has reverse fed through the pump, then turn the pump off.
4. Loosen small clamp at the pick-up hose adapter and (Viewed from Back) disconnect mix pump hose.
5. Cut 7-1/2" (19 cm) off the end of the mix pump hose.
6. Reconnect mix pump hose to adapter.
7. Continue normal operation. Mix hose will automatically reposition itself with adapter near black cover.

NOTICE

Each hose is long enough for 3 repositions before replacement is required. Record each event on Hose Service Record decal.

4.5 MIX PUMP HOSE REPLACEMENT

NOTICE

Mix pump hose must be replaced when tubing cannot be further repositioned (every four to eight weeks). Failure to comply will result in hose failure and possible pump damage.

1. Run cleaning solution through pump.
2. Turn pump off and relieve any pressure by opening the spigot.

 WARNING
The Mix pump switch must be in the "Off" position when servicing or cleaning pumps.

CAUTION
Never disconnect hoses from freezer or pump without first opening spigot to relieve pressure.

3. Disconnect mix pump hose at each end.
4. Grasp the discharge hose end with one hand and turn the pump on. Pull down on the hose until all of the remaining hose is removed from the pump.
5. Connect new mix pump hose to pick-up hose adapter, using small clamp.
6. Insert free end of hose into the pick-up (suction side) hose side of the black cover. Gently push the hose into the black cover until it begins to self-feed. Allow the hose to feed itself through the pump until the pick-up hose adapter prevents further feeding, then turn the pump off.
7. Reconnect mix pump hose to T using small clamp. Pump is now ready to sanitize.

4.6 CAB TEMPERATURE ADJUSTMENT

A temperature control is used to control cab temperature. To change the temperature, follow the steps below:

- A. Remove the six screws holding the left side panel and remove panel.
- B. Use a small screwdriver to adjust the temperature control. Turn counterclockwise for a warmer temperature and clockwise for a colder temperature. It will take about an hour for the cab temperature to change. Figure 28.
- C. Install side panel and secure with the six retaining screws.

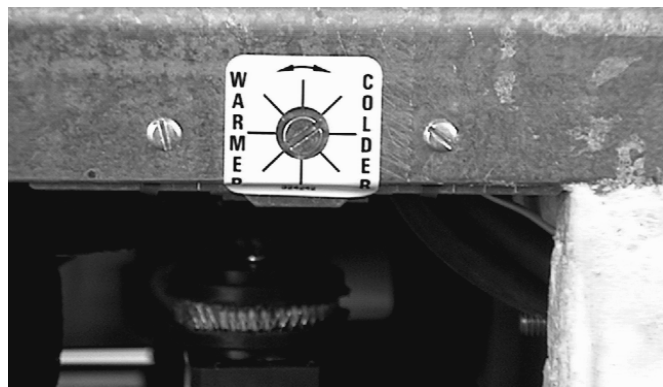



Figure 29. Temperature Control Cab

4.7 DRIVE BELT TENSION ADJUSTMENT

To check belt tension, refer to Figure 29 and follow the steps below:

 WARNING
Disconnect electrical supply to freezer before servicing.

- A. Remove either side and back panels.
- B. Press firmly on one belt. Figure 29.

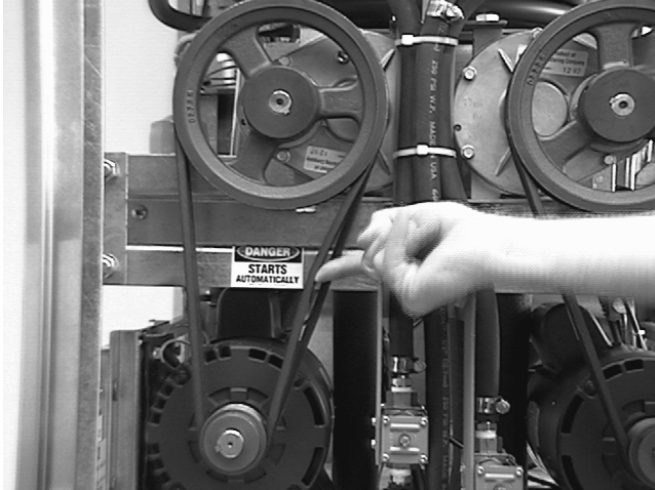

Figure 30. Belt Adjustment

- C. When the tension is properly adjusted, the outside of the depressed belt should be approximately in line with the inside of the other belt.
- D. If an adjustment is necessary, loosen the four motor plate retaining nuts, adjust belt tension then re-tighten the four nuts.

NOTICE

Belt life will be increased if new drive belts are tightened after two or three weeks of operation.

4.8 CONDENSER CLEANING (AIR-COOLED FREEZERS)

The condenser requires periodic cleaning. To clean the condenser, refer to the following steps:

NOTICE

Some freezers have a condenser filter, to clean remove and wash in warm soapy water. Rinse in clean water and shake dry, taking care not to damage filter in any way.

- A. Visually inspect the condenser for dirt.
- B. If the condenser is dirty, place a wet towel over the condenser.
- C. Using compressed air or CO2 tank, blow out the dirt from the back of the condenser. Most of the dirt will cling to the wet towel.

CAUTION
<p>This procedure emits a loud noise. Wear hear protection to prevent hearing loss.</p>

- D. An alternative method is to clean with a condenser brush and vacuum.

NOTICE

If the condenser is not kept clean, loss of refrigeration efficiency will result.

4.9 PREVENTATIVE MAINTENANCE

It is recommended that a preventative maintenance schedule be followed to keep the freezer clean and operating properly. The following steps are suggested as a preventative maintenance guide.

WARNING
<p>Never attempt to repair or perform any maintenance on freezer until all main electrical power has been disconnected.</p>

The United States Department of Agriculture and the Food and Drug Administration require that lubricants used in food zones be certified for this use. Use lubricants only in accordance with the manufacturer's instructions.

A. Daily Checks

Check for any unusual noise or condition and repair immediately.

B. Month Checks

1. Check drive belts for wear and tighten belts if necessary. (Refer to Section 4.7.)
2. Check the condenser for dirt. (Refer to Section 4.8).

WARNING
<p>Never attempt to repair or perform any maintenance on freezer until all main electrical power has been disconnected.</p>

4.10 EXTENDED STORAGE

Refer to the following steps for winterizing the freezer or for storing the freezer over any long period of shutdown time.

- A. Clean thoroughly with warm detergent all parts that come in contact with mix. Rinse in clear water and dry all parts. Do not sanitize.

NOTICE

Do not let cleaning solution stand in freezer barrel or mix pump during the shutdown period.

- B. Remove, disassemble, and clean the front door, auger shaft, and mix pump. Leave disassembled during the shutdown period.
- C. Place plastic auger flights in a plastic bag with a moist paper towel. This will prevent flights from becoming brittle if exposed to dry air over an extended period of time (over 30 days).

- D. For water-cooled freezers that are left in unheated buildings, or buildings subject to freezing, the water must be shut off and disconnected. Disconnect fittings at water valve inlet and water outlet lines at the freezer. The fittings are located at the rear of the freezer. Run the compressor for 2 - 3 minutes to open water valve. Blow out all water, first through water inlet, then through water outlet lines with air or carbon dioxide. Also drain water supply line to the freezer.
- E. Place the mix pump ON-OFF switch, and the CLEAN-OFF-SERVE switch in the OFF position.
- F. Disconnect from the source of electrical supply in the building.

4.11 TROUBLESHOOTING

The Troubleshooting Table lists the common problems that can occur to the freezer.

FREEZER

PROBLEM	FREEZER POSSIBLE CAUSE	REMEDY
Drive motor (auger) "kicks-out", or does not run.	<ol style="list-style-type: none"> 1. Power to freezer is off. 2. Drive motor overloaded. 3. Low line voltage. 4. Product too hard. 5. Front door not installed securely. 	<ol style="list-style-type: none"> 1. Check power to freezer. 2. Wait 15-20 min. for Thermo overload to reset. 3. Check, must be +/-10% of nameplate voltage. 4. Raise overrun and/or product temperature. (See Section 4.3 or 4.2) 5. Install front door securely.
Compressor does not operate.	<ol style="list-style-type: none"> 1. Power to freezer if off. 2. Drive motor overloaded. 3. Low line voltage. 4. Compressor internal overload is cut-out. 5. Front door not installed securely. 	<ol style="list-style-type: none"> 1. Check power to freezer. 2. Wait 15-20 min. for Thermo overload to reset. 3. Check, must be +/-10% of nameplate voltage. 4. Check condenser (air cooled)(See Sect. 4.8), or water supply (water cooled). 5. Install front door securely.
Product too soft.	<ol style="list-style-type: none"> 1. Temperature setting is too high. 2. Product break down. 3. Standby/Serve Switch in Standby position. 	<ol style="list-style-type: none"> 1. Adjust temperature. (See Section 4.2) 2. Fill with fresh product. 3. Place Standby/Serve Switch in Serve position.
Freeze-up. (Product will not dispense easily.)	<ol style="list-style-type: none"> 1. Temperature setting is too low. 2. Low overrun setting. 3. Low pump pressure. 4. Large air pocket in barrel. 5. Auger turning counter-clockwise. 	<ol style="list-style-type: none"> 1. Adjust temperature. (See Section 4.2) 2. Raise overrun. (See Section 4.3) 3. Check pump pressure. 4. Purge air from barrel. 5. Change rotation to clockwise.
Rear auger seal leaks.	<ol style="list-style-type: none"> 1. Rear auger seal not lubricated. 2. Seal missing or installed wrong. 3. Worn or scratched shaft. 	<ol style="list-style-type: none"> 1. Lubricate seal. (See Section 3.8) 2. Check. (See Section 3.8) 3. Replace shaft.
Spigot leaks.	<ol style="list-style-type: none"> 1. Spigot parts are not lubricated. 2. Chipped or worn o-rings. 3. O-rings on spigot installed wrong. 4. Nicks or scratched on front door where spigot is located. 	<ol style="list-style-type: none"> 1. Lubricate. (See Section 3.8) 2. Replace O-rings. 3. Remove spigot and check O-rings. 4. Replace front door.
Drive belts slipping or squealing.	<ol style="list-style-type: none"> 1. Drive belt tension not correct. 2. Worn belt(s). 3. Temperature setting is too low. 4. Low overrun. 	<ol style="list-style-type: none"> 1. Adjust belt tension. (See Section 4.7) 2. Replace belts. 3. Adjust temperature. (See Section 4.2) 4. Check for air leak.
Mix temperature too warm in cab.	<ol style="list-style-type: none"> 1. System low on refrigerant. 2. Temperature control set too warm. 	<ol style="list-style-type: none"> 1. Add refrigerant. (Refrig. Service) 2. Remove left side panel and locate temperature control and follow instructions on decal.
Mix temperature too cold in cab.	<ol style="list-style-type: none"> 1. Temperature control set too cold. 	<ol style="list-style-type: none"> 1. Remove left side panel and locate temperature control and follow instructions on decal.

MIX PUMP

1. PUMP MOTOR DOES NOT RUN

Power to pump is off.	Supply power to pump.
Low voltage.	Check for low line voltage.
Mix pump hose jammed inside black cover/clamp.	Disconnect pump from power source. Remove four cover/clamp thumb screws. Separate cover/clamp halves and remove outer half. Remove jammed hose. Re-install cover/clamp and tighten four thumb screws securely. Allow motor thermal overload to reset. See Sec. 2.5 for hose replacement. Do not use jammed portion of hose.
Pump motor overloaded.	Allow internal thermal overload to reset; determine overload cause and repair.
Pressure switch on pump is defective.	Contact your local Stoelting Distributor.
Defective motor/capacitor	Contact your local Stoelting Distributor.
Defective toggle switch.	Contact your local Stoelting Distributor.

2. PUMP OPERATES BUT CYLINDER WILL NOT FILL

NOTE 1: A PROPERLY WORKING PUMP WILL FILL AN 8 OZ. CUP WITH MIX IN ABOUT 9 SECONDS.

NOTE 2: IMMEDIATELY AFTER A "BAG CHANGE" THE PUMP MAY BE UNABLE TO RE-ESTABLISH IT'S PRIME WITH THE SYSTEM AT OPERATING PRESSURE. IN THIS CASE, TURN THE PUMP OFF. DRAW 2-3 PINTS TO REDUCE SYSTEM PRESSURE TO ZERO. TURN PUMP ON. PURGE REMAINING AIR IN MIX BAG AND PICK-UP HOSE.

IMPORTANT: Before connecting the pick-up hose to the mix bag, purge the mix bag of air to the extent possible.

Out of Mix.	Replenish mix supply.
Mix pump hose kinked inside black cover/clamp.	Follow mix pump hose jammed repair. (See #1 above.)
Hoses assembled incorrectly.	Refer to diagram for correct hose connections.
Mix pump hose service life is exceeded.	Reposition/replace mix pump hose. See Sec. 2.5.
Mix pump hose not connected to freezer.	Connect mix pump hose to freezer.
Ice crystals in mix.	Completely thaw mix prior to use.
Mix bag drawn against adapter.	Assure bag is clear of pick-up tube.
Foreign objects in mix.	Clear blockage. Use fresh mix.
Mix Check Valve is installed backwards.	Observe flow arrow for proper orientation.

3. OVERRUN TOO LOW OR NO OVERRUN

Overrun setting too low.	Increase overrun setting.
Air leak.	Tighten all hose clamps.
Air compressor not pumping air.	Contact local Stoelting Distributor.

4. OVERRUN TOO HIGH

Mix pump hose service life is exceeded.	Reposition/replace mix pump hose.
Out of mix.	Replenish mix supply.
Overrun setting too high.	Decrease overrun setting.
Pick-up leg of mix pump hose is collapsing.	See Section 2.5.

NOTE: ALSO SEE "2" ABOVE.

5. REPLACEMENT MIX PUMP HOSE WON'T FEED THROUGH PUMP	
Feeding hose into discharge hole of mix pump cover.	Feed hose into pick-up side of cover.
Hose ends not cut squarely.	Carefully cut hose end off squarely (no tails).
Force feeding too quickly.	Gently and slowly assist feeding of hose up into pick-up hose side of cover.
Pump motor not running.	Turn on motor switch. Also see Item 1 above.
6. AIR EXITING MIX PICK-UP HOSE	
Pickup tube check valve missing.	Contact local Stoelting Distributor.
7. DISPENSED PRODUCT AIR "POPS"	
Overrun setting too high.	Reposition/replace mix pump hose.
Mix pump hose service life is exceeded.	Reposition/replace mix pump hose.
Overdrawing the freezer's capacity.	Reduce dispense rate.
Recent "mix-out" condition.	Open spigot fully and allow excess air to "belch" out.
NOTE: ALSO SEE 2 & 4 ABOVE.	
8. MIX LEAKAGE FROM PUMP	
<i>CAUTION: To prevent mix pump damage from dried mix deposits, immediately disassemble and clean pump.</i>	
Mix pump hose service life is exceeded.	Remove mix pump hose. Disconnect pump from power source. Remove mix pump cover/clamp. THOROUGHLY rinse three squeeze rollers using a spray bottle filled with hot water. Thoroughly clean all mix from pump. See Sec. 2.5 for hose replacement.
9. PUMP HAS POOR CAPACITY	
Lift and run limits are exceeded.	Pump is limited to 10' lift, 20' run.
NOTE: Also see 2, 4, 6 & 7.	
10. PUMP IS NOISY/SQUEAKING	
NOTE: THE ACTION OF THE AIR COMPRESSOR ROCKING ARM CREATES A REPETITIVE CLICKING SOUND DURING OPERATION. THIS IS NORMAL.	
11. MIX IN AIR HOSES	
Air/mix tee above black cover/clamp.	Air/mix tee must be below black cover/clamp.
Air leak.	Tighten all hose clamps.
Mix hose on wrong air/mix tee fitting.	Refer to diagram for correct hose connections.

SECTION 5 HOW TO ORDER REPLACEMENT PARTS

5.1 HOW TO ORDER REPLACEMENT PARTS

To assure the receipt of the proper replacement parts, supply your Authorized Stoelting Distributor with the following information:

- A. Model number of equipment.
- B. Serial number of model (stamped on nameplate)
- C. Part number, part name, and quantity needed.

NOTICE

Minimum billing is \$50.00 Net.

5.2 PARTS LIST AND REFERENCE DRAWINGS

The following lists and drawings will aid the user when ordering parts or servicing.

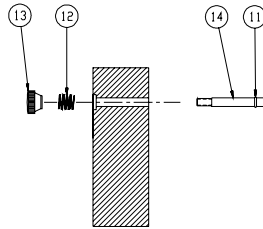
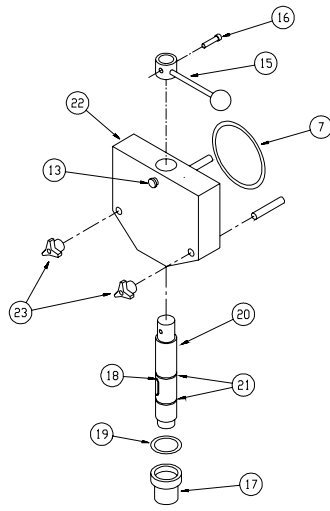

FRONT DOOR PARTS

Drawing Index No.	Part No.	Description
7	625133	O-ring, Front Door
11	624520	O-ring, Air Bleed Valve
12	694200	Spring, Air Bleed Valve
13	482004	Knob, Air Bleed, Black
14	2110116	Stem, Air Bleed Valve
15	1107123	Spigot Handle
16	570998	Retaining Pin
17	2146293	Spigot Extension, 2.1
	2157892	Spigot Extension, 1.5
	2143024	Spigot Extension, 3.2
18	624655	Spigot O-ring
19	624645	Spigot Extension O-ring
20	3152581	Spigot, White
21	624677	Spigot O-ring
22	1177905	Front Door
23	482035	Knob, Black

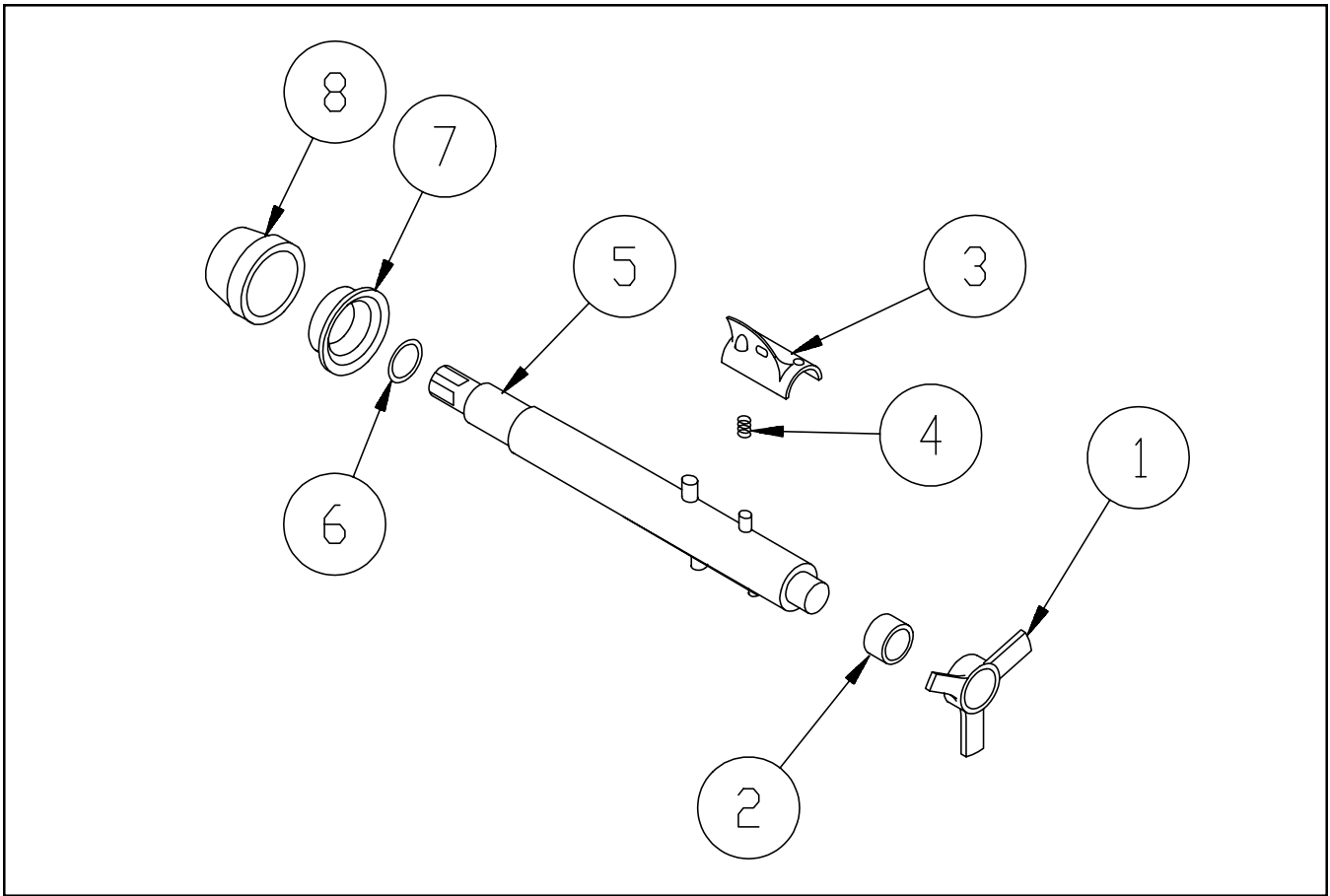

AUGER PARTS

Drawing Index No.	Part Number	Qty.	Description
1	2104552	1	Auger Front Support
2	149003	1	Front Bearing
3	381804	6	Plastic Flight
4	694255	6	Spring
5	4151178	1	Auger
6	624678	1	Rear Seal O-ring
7	1151859	1	Rear Seal Adaptor
8	667868	1	Rear Seal

MISCELLANEOUS PARTS

Description	Part No.
Haynes Spray 12 oz.(340 grams) -----	508017
Petro-Gel Tube 4 oz. (113 grams) -----	508135
Spline Lubricant 2 oz. (57 grams) -----	508048
Brush 4"x 8"x16" (10cm x 20cm x 40,5cm) -----	208135
Brush 2.5"x 4"x12" (6,5cm x 10cm x 30,5cm) ----	208146
Brush .25"x 4"x14" (.6cm x 10cm x 35,5cm) ----	208380
Brush 1"x3.5"x18" (2,5cm x 9cm x 45,5cm) -----	208465
Drip Tray -----	744273
Drip Tray Grid -----	417006

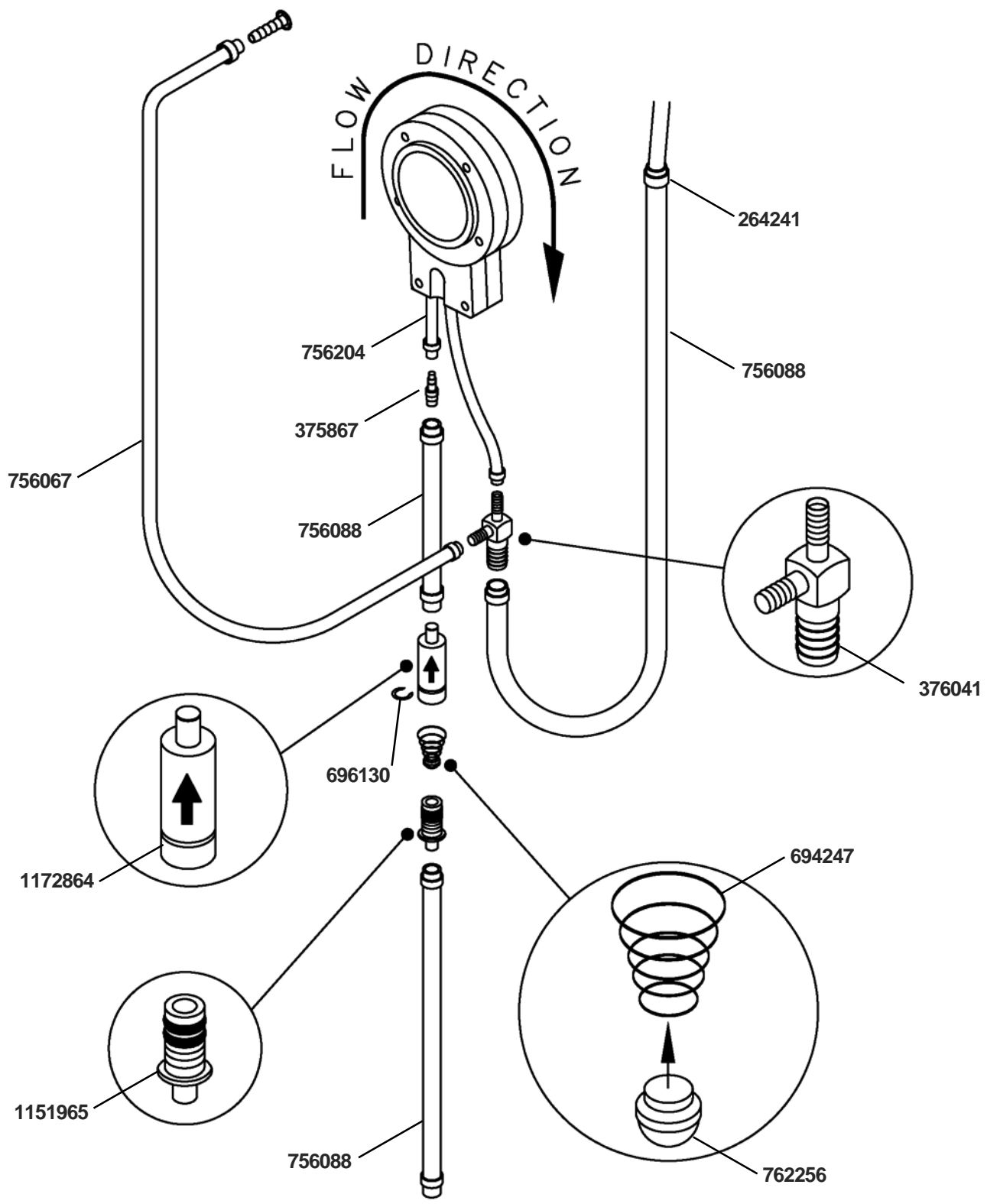

Figure 7. Mix Pump

DECALS

Qty.	Part Number	Description
2	324200	H.P. Manual Reset
2	324798	Clean-Off-Serve
2	324797	Standby/Serve
1	324800	Cab Off-On
2	324799	Pump Off On
1	324141	Caution, Haz. Rot. Blade - Front Panel
1	324509	Cleaning - Right Side
2	324014	Auger Rotation - Evap. Enclosure Rear
4	324686	Danger - Start Auto, on Evap. Support between belts & motors support brkt.
1	723525	Winterizing, Attach to water hose near bottom
2	324106	Caution - Elec. Wiring Mat'ls must conform between water couplings, one rear panel bottom
2	324346	Caution - Haz. Mov. Parts, on inside of mtr support brkt @ rear
3	324107	Caution - Haz. Mov. Parts, on cond. bkt. rear & (2) on evap. enclosure sides
2	324208	Attn - Ref. Lk Chk, on evap. enclosure sides
2	723552	Tag - Supply volt., inside J-Box
1	723517	Card - Inside one J-Box
2		ID Tags, Back Panel Top
1	324548	Add. Vent Back Panel Ctr Top
1		Made in U.S.A. - Back panel
2	324103	Caution - Rot. Shaft, on gearbox support bracket
2	324151	Field Connections, J-Box cover, outside
3	324125	Danger Elec.Shock, J-Box covers outside, back panel bottom
1	324242	Warm/Cold, @ T-Stat
2	324565	Night/Serve - Temp. Control Bracket
2	324158	Use copper cond. only, inside both J-boxes
2	324566	Wired According to, on elec. schematic envelope
2	130000	Elec. Schematic Envelope
1	324065	Water Inlet - Back panel above inlet coupling
1	324803	Header panel decal (Stoelting Logo)
1	324804	Header panel decal (Stoelting Swirl)
1	324805	Header panel decal (DQ Logo)



WARRANTY SOFT SERVE / SHAKE FREEZERS

1. Scope:

Stoelting, LLC warrants to the first user (the "Buyer") that the freezer cylinders, hoppers, compressors, drive motors, speed reducers, augers and auger flights of Stoelting soft serve / shake freezers will be free from defects in materials and workmanship under normal use and proper maintenance appearing within five (5) years, and that all other components of such equipment manufactured by Stoelting will be free from defects in material and workmanship under normal use and proper maintenance appearing within twelve (12) months after the date that such equipment is originally installed.

2. Disclaimer of Other Warranties:

THIS WARRANTY IS EXCLUSIVE; AND STOELTING HEREBY DISCLAIMS ANY IMPLIED WARRANTY OF MERCHANTABILITY OR FITNESS FOR PARTICULAR PURPOSE.

3. Remedies:

Stoelting's sole obligations, and Buyer's sole remedies, for any breach of this warranty shall be the repair or (at Stoelting's option) replacement of the affected component at Stoelting's plant in Kiel, Wisconsin, or (again, at Stoelting's option) refund of the purchase price of the affected equipment, and, during the first twelve (12) months of the warranty period, deinstallation/reinstallation of the affected component from/into the equipment. Those obligations/remedies are subject to the conditions that Buyer (a) signs and returns to Stoelting, upon installation, the Checklist/Warranty Registration Card for the affected equipment, (b) gives Stoelting prompt written notice of any claimed breach of warranty within the applicable warranty period, and (c) delivers the affected equipment to Stoelting or its designated service location, in its original packaging/crating, also within that period. Buyer shall bear the cost and risk of shipping to and from Stoelting's plant or designated service location.

4. Exclusions and Limitations:

This warranty does not extend to parts, sometimes called "wear parts", which are generally expected to deteriorate and to require replacement as equipment is used, including as examples but not intended to be limited to o-rings, auger seals, auger support bushings and drive belts. All such parts are sold

AS IS.

Further, Stoelting shall not be responsible to provide any remedy under this warranty with respect to any component that fails by reason of negligence, abnormal use, misuse or abuse, use with parts or equipment not manufactured or supplied by Stoelting, or damage in transit.

THE REMEDIES SET FORTH IN THIS WARRANTY SHALL BE THE SOLE LIABILITY STOELTING AND THE EXCLUSIVE REMEDY OF BUYER WITH RESPECT TO EQUIPMENT SUPPLIED BY STOELTING; AND IN NO EVENT SHALL STOELTING BE LIABLE FOR ANY INCIDENTAL OR CONSEQUENTIAL DAMAGES, WHETHER FOR BREACH OF WARRANTY OR OTHER CONTRACT BREACH, NEGLIGENCE OR OTHER TORT, OR ON ANY STRICT LIABILITY THEORY.