



ADA Compliant

This Space for Architect/Engineer Approval

Job Name _____ Date _____

Model Specified _____ Quantity _____

Customer/Wholesaler _____

Contractor _____

Architect/Engineer _____

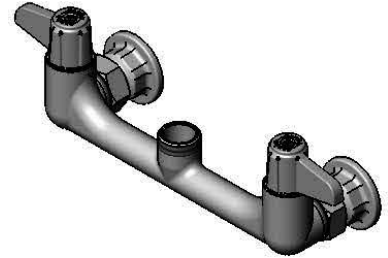
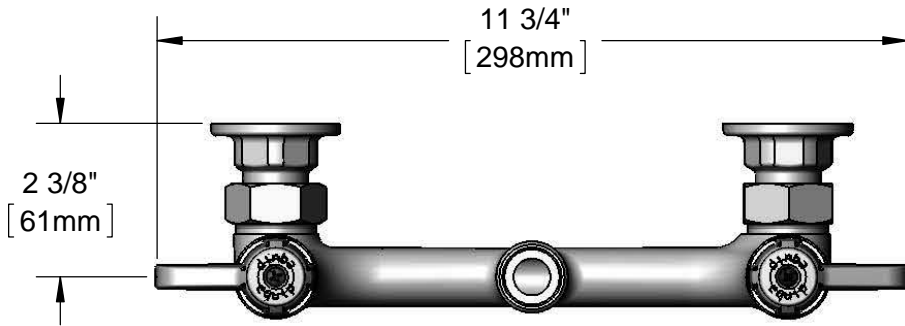

Swivel Outlet Accepts
equip Swing Nozzles.
Conversion to Rigid Requires
014200-45 Lock Washer
(Sold Separately)

Ceramic Cartridges &
equip Lever Handles
w/ Color Coded Screws

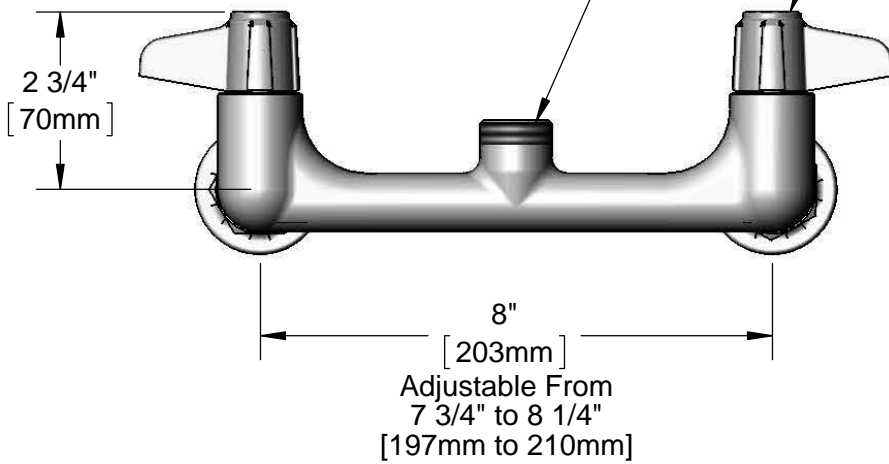

Ø 2" [51mm]
Flanges w/
1/2" NPT
Female Inlets

Mounting Surface

Model Number

5F-8WLX00

Product Specifications:

**8" Wall Mount Mixing Faucet, Ceramic Cartridges,
equip Lever Handles & 1/2" NPT Female Inlets, Less Nozzle**

Product Compliance:

ASME A112.18.1 / CSA B125.1
NSF 61 - Section 9
NSF 372 (Low Lead Content)
ANSI A117.1 (ADA)

equip
Foodservice
Accessories

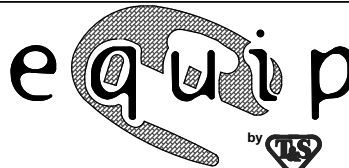

2 Saddleback Cove, P.O. Box 1088
Travelers Rest, South Carolina 29690
Phone: 800.891.4808 Fax: 800.868.0084
equip.tsbrass.com

ITEM NO.	SALES NO.	DESCRIPTION
1	5-HDL-L	equip Lever Handle w/ Color Coded Screws
2	00AA	1/2" NPT Female Eccentric Flange
3	001019-45	Coupling Nut Washer
4	013788-45	equip Ceramic Cartridge, LTC
5	013787-45	equip Ceramic Cartridge, RTC

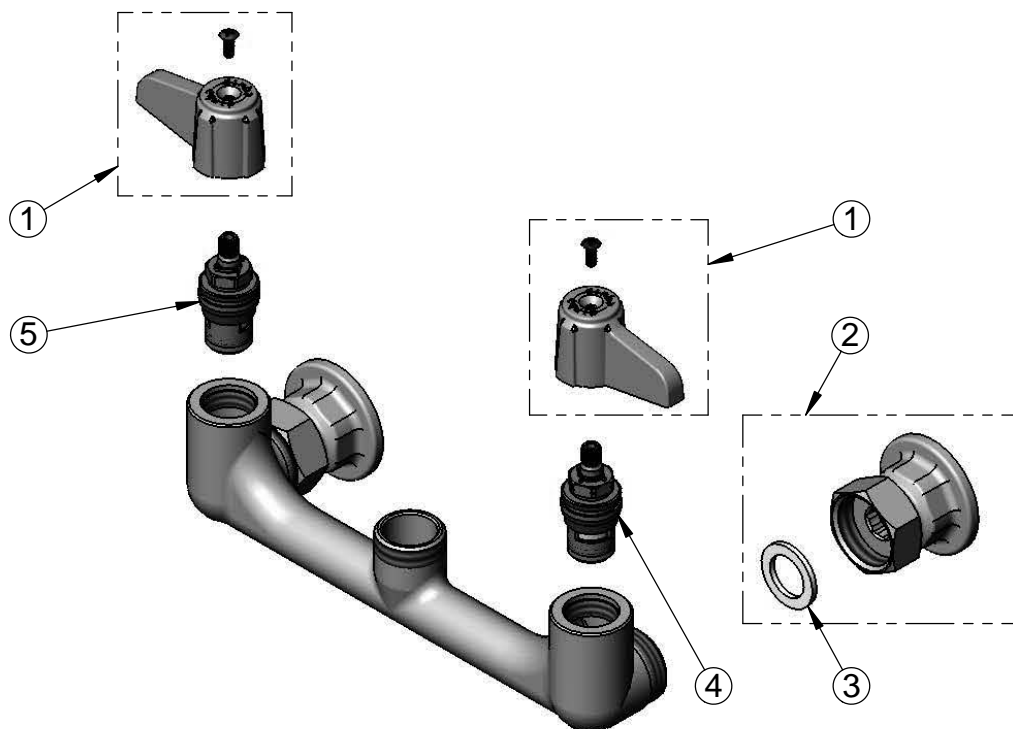

Model Number

5F-8WLX00

Product Specifications:

**8" Wall Mount Mixing Faucet, Ceramic Cartridges,
equip Lever Handles & 1/2" NPT Female Inlets, Less Nozzle**

Product Compliance:

ASME A112.18.1 / CSA B125.1
NSF 61 - Section 9
NSF 372 (Low Lead Content)
ANSI A117.1 (ADA)

equip
Foodservice
Accessories

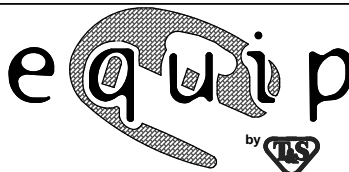

2 Saddleback Cove, P.O. Box 1088
Travelers Rest, South Carolina 29690
Phone: 800.891.4808 Fax: 800.868.0084
equip.tsbrass.com