

*This Space for Architect/Engineer Approval*

Job Name \_\_\_\_\_ Date \_\_\_\_\_

Model Specified \_\_\_\_\_ Quantity \_\_\_\_\_

Customer/Wholesaler \_\_\_\_\_

Contractor \_\_\_\_\_

Architect/Engineer \_\_\_\_\_

**EPAct 2005 Compliant**

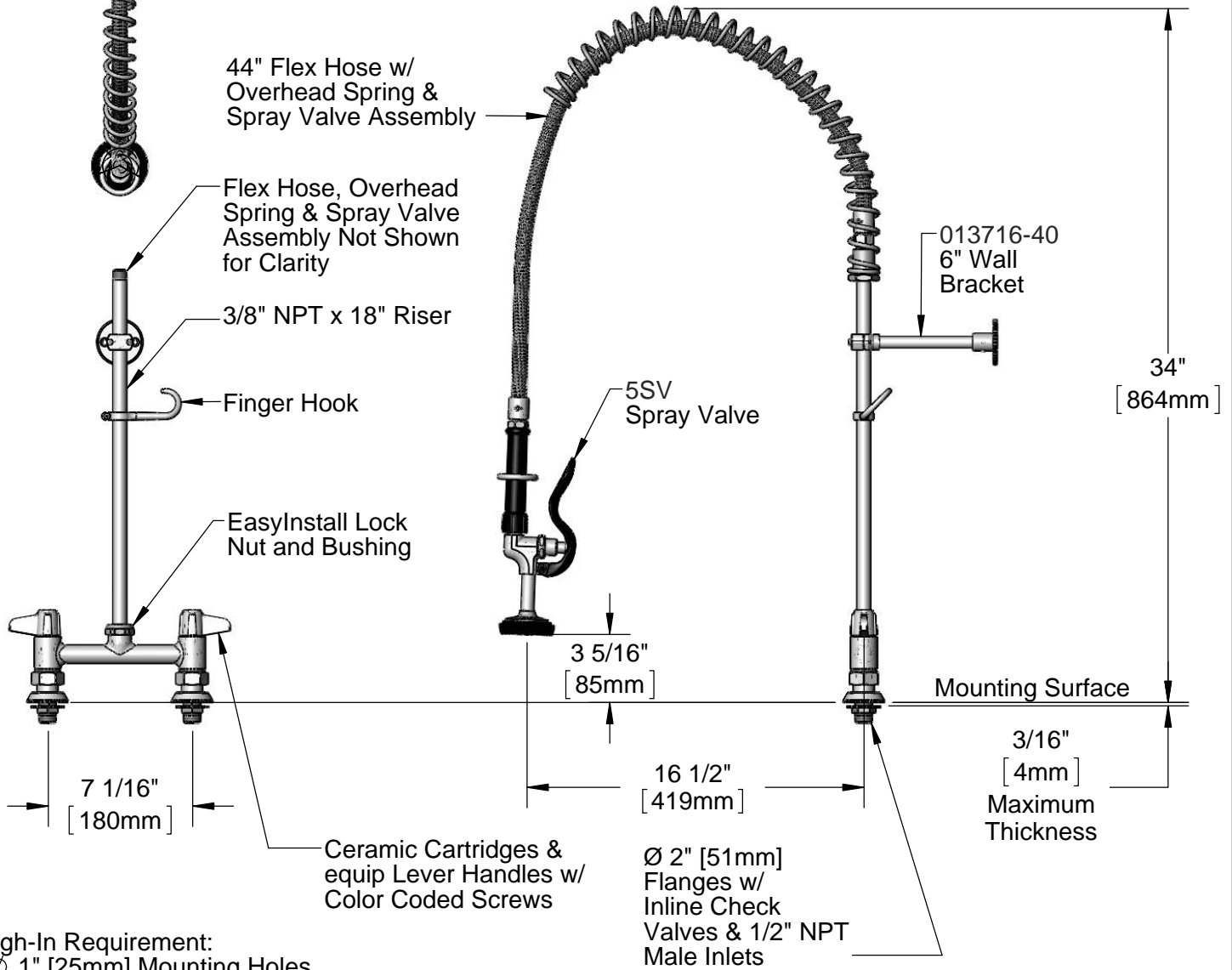

**Rough-In Requirement:**  
(2) Ø 1" [25mm] Mounting Holes

Model Number 5PR-7D00-EZ-EE	Date 08/08/12	Scale 1:8	Drawn DHL	Checked DMH	Approved JHB
--------------------------------	------------------	--------------	--------------	----------------	-----------------



Product Specifications:  
**Pre-Rinse Unit: EasyInstall 180mm Deck Mount Mixing Faucet w/ 6" Wall Bracket, 5SV Spray Valve, In-Line Check Valves, 44" Flex Hose & 1/2" NPT Male Inlets**

equip Foodservice Accessories  
 2 Saddleback Cove, P.O. Box 1088  
 Travelers Rest, South Carolina 29690  
 Phone: 800.891.4808 Fax: 800.868.0084

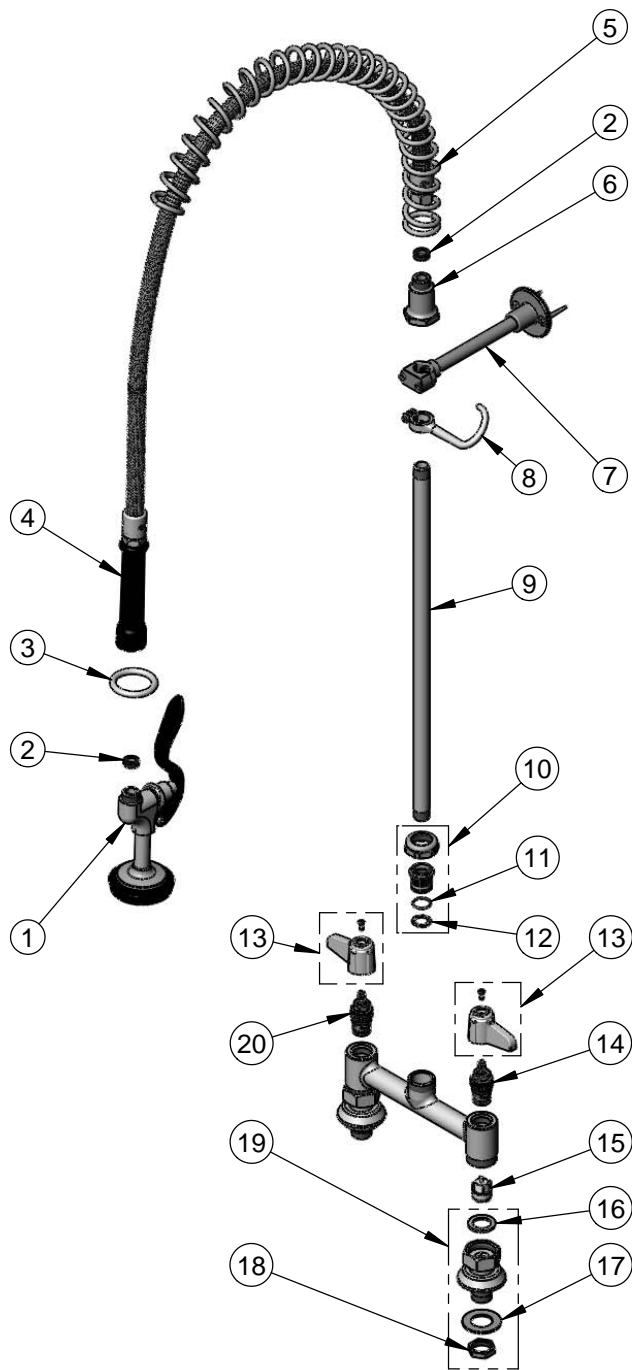

PART NO.	SALES NO.	DESCRIPTION
1	5SV	Spray Valve Assembly
2	010476-45	#27 Washer
3	000907-45	Spray Valve Hold Down Ring
4	5HSE44	44" Flex Hose Assembly (Includes Washer)
5	014068-45	Overhead Spring
6	000821-40	Spring Body
7	013716-40	6" Wall Bracket Assembly
8	004R	Finger Hook
9	000369-40	3/8" NPT x 18" Long Riser
10	EU-EZ-K	Euro EasyInstall Kit
11	001062-45	O-Ring
12	014200-45	Star Washer, Anti-Rotation
13	5-HDL-L	equip Lever Handle w/ Color Coded Screws
14	013788-45	equip Ceramic Cartridge (LTC)
15	013840-45	20mm Check Valve (2)
16	001019-45	Coupling Nut Washer
17	000999-45	Brass Lock Washer
18	002954-45	Shank Lock Nut
19	00EE	1/2" NPT Male Inlet Flange
20	013787-45	equip Ceramic Cartridge, RTC

Model Number 5PR-7D00-EZ-EE	Date 08/08/12	Scale NTS	Drawn DHL	Checked DMH	Approved JHB
--------------------------------	------------------	--------------	--------------	----------------	-----------------



Product Specifications:  
**Pre-Rinse Unit: EasyInstall 180mm Deck Mount Mixing Faucet w/ 6" Wall Bracket, 5SV Spray Valve, In-Line Check Valves, 44" Flex Hose & 1/2" NPT Male Inlets**

equip Foodservice Accessories  
 2 Saddleback Cove, P.O. Box 1088  
 Travelers Rest, South Carolina 29690  
 Phone: 800.891.4808 Fax: 800.868.0084