



T&S BRASS AND BRONZE WORKS, INC.
 2 Saddleback Cove / P.O. Box 1088
 Travelers Rest, SC 29690

Model No.
B-0296-18DJ-CKP

Item No.

Travelers Rest, SC: 800-476-4103 • Simi Valley, CA: 800-423-0150 • Fax: 864-834-3518 • www.tsbrass.com



ADA Compliant

This Space for Architect/Engineer Approval

Job Name _____ Date _____

Model Specified _____ Quantity _____

Customer/Wholesaler _____

Contractor _____

Architect/Engineer _____

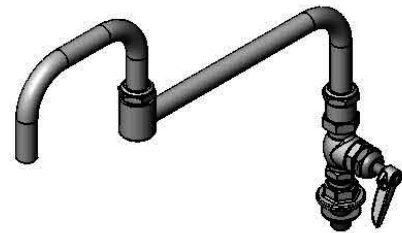
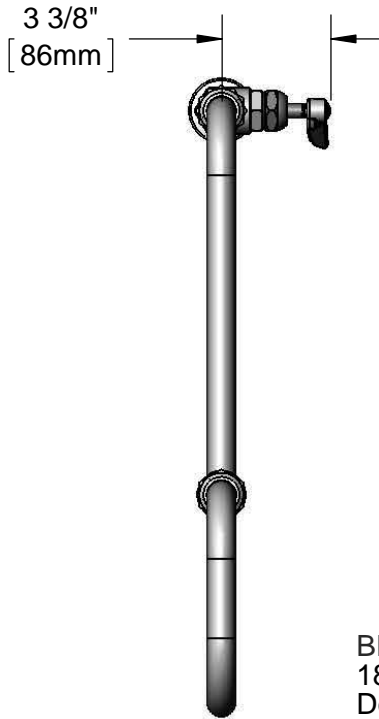

BF-0178-A
 18" Big-Flo
 Double Joint
 Nozzle w/
 Plain End Outlet

Lever Handle w/
 Blue (CW) Color
 Index

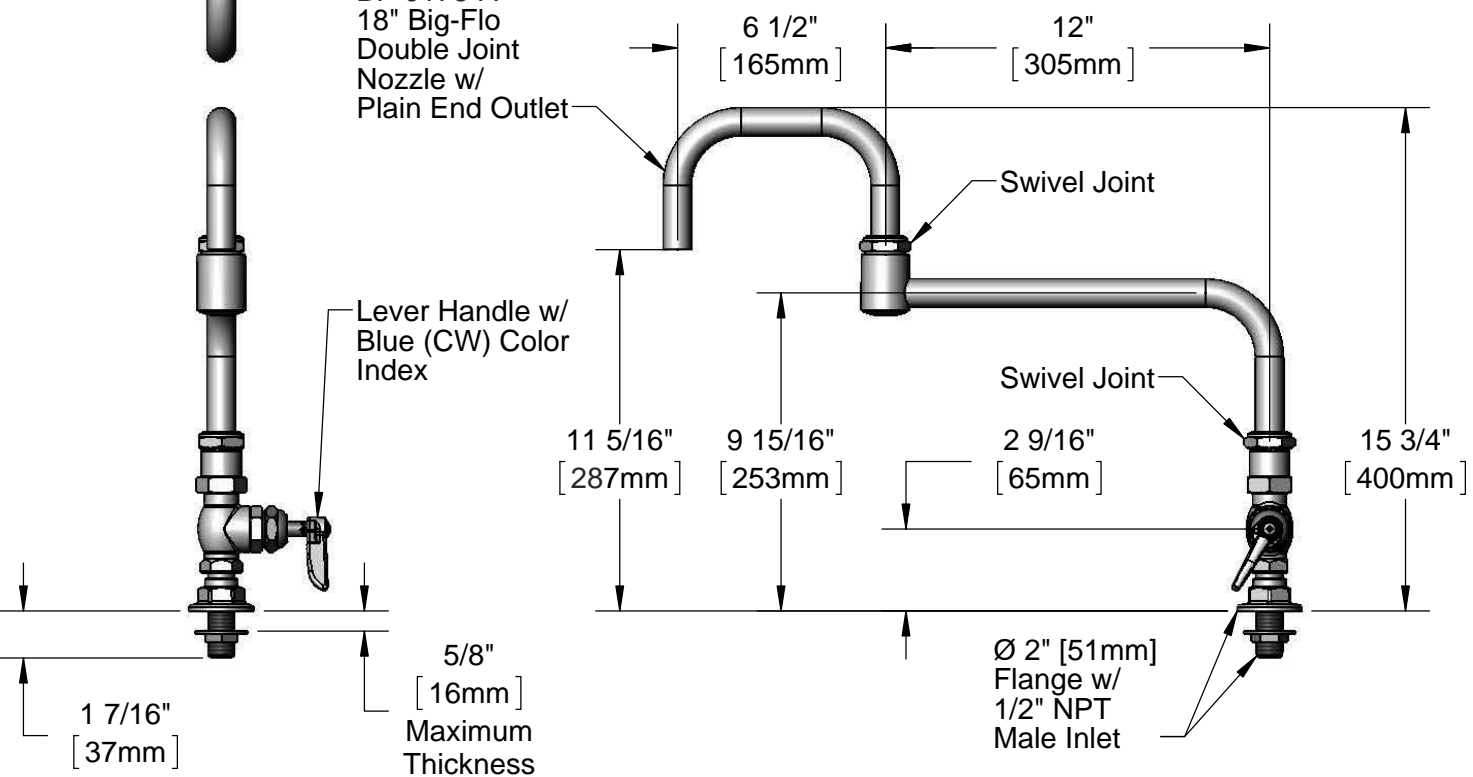

Rough-In Requirement:
 Ø 1" [25mm] Mounting Hole

Product Specifications:
 Big-Flo Valve Faucet w/ Lever Handle, 18" Big-Flo Double Joint Nozzle
 w/ Plain End Outlet & 1/2" NPT Male Inlet

Drawn DHL	Checked JRM	Approved JHB
---------------------	-----------------------	------------------------

Scale: 1:6	Date: 01/08/13
----------------------	--------------------------



T&S BRASS AND BRONZE WORKS, INC.
 2 Saddleback Cove / P.O. Box 1088
 Travelers Rest, SC 29690

Model No.
B-0296-18DJ-CKP
 Item No.

Travelers Rest, SC: 800-476-4103 • Simi Valley, CA: 800-423-0150 • Fax: 864-834-3518 • www.tsbrass.com

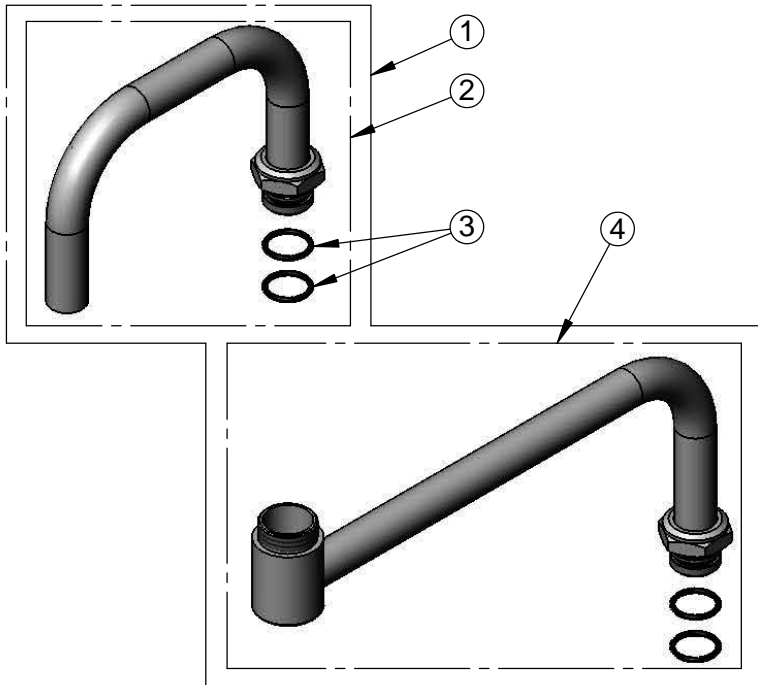

ITEM NO.	SALES NO.	DESCRIPTION
1	BF-0178-A	Big-Flo 18" Double Joint Swing Nozzle
2	BF-0153-X	Big-Flo 18" Double Joint, 6" Front Section
3	001068-45	O-ring, Size -118
4	118X	Big-Flo 18" Double Joint, 12" Back Section
5	002534-25	Close Nipple, 1/2" NPT Rough Chrome
6	000764-20	Seat, Big-Flo
7	006482-40	Big-Flo Spindle, RTC
8	001638-45	Lever Handle
9	001660-45	Blue Index-CW
10	000922-45	Lever Handle Screw
11	000013-40	Flange, 1/2" NPT Wall Mount
12	B-0425	1/2" NPT Supply Nipple Kit
13	000999-45	Brass Lock Washer
14	002954-45	Shank Lock Nut
15	000594-25	Swivel Body x 1/2-14 NPT

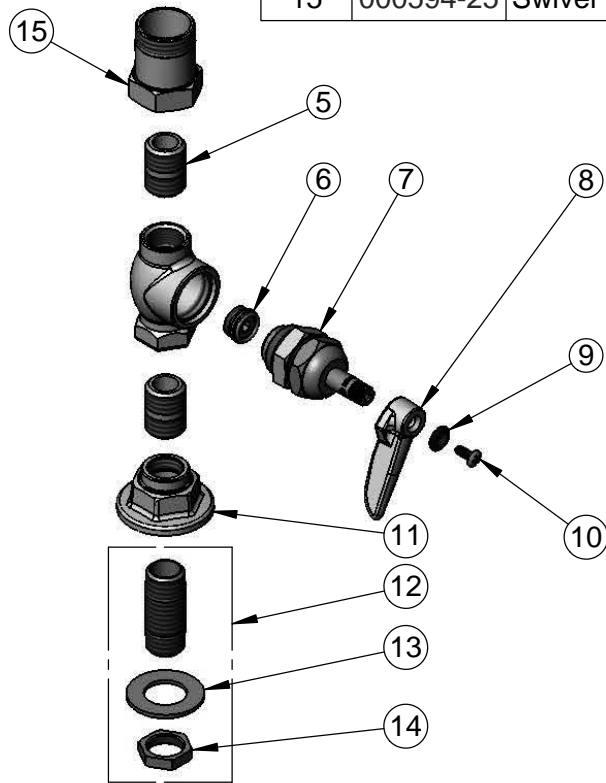

Product Specifications:
 Big-Flo Valve Faucet w/ Lever Handle, 18" Big-Flo Double Joint Nozzle
 w/ Plain End Outlet & 1/2" NPT Male Inlet

Drawn DHL	Checked JRM	Approved JHB
Scale: NTS		Date: 01/08/13