



**T&S BRASS AND BRONZE WORKS, INC.**  
 2 Saddleback Cove / P.O. Box 1088  
 Travelers Rest, SC 29690

Model No.  
**B-0502-BT**

Item No.

Travelers Rest, SC: 800-476-4103 • Simi Valley, CA: 800-423-0150 • Fax: 864-834-3518 • www.tsbrass.com

This Space for Architect/Engineer Approval

Job Name \_\_\_\_\_ Date \_\_\_\_\_

Model Specified \_\_\_\_\_ Quantity \_\_\_\_\_

Customer/Wholesaler \_\_\_\_\_

Contractor \_\_\_\_\_

Architect/Engineer \_\_\_\_\_

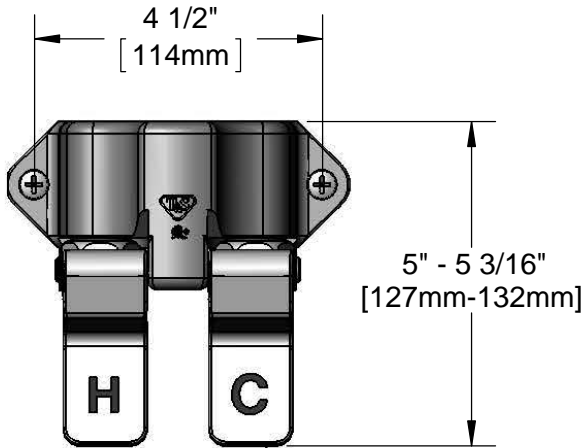

Chrome Plated  
 Brass Foot Pedals

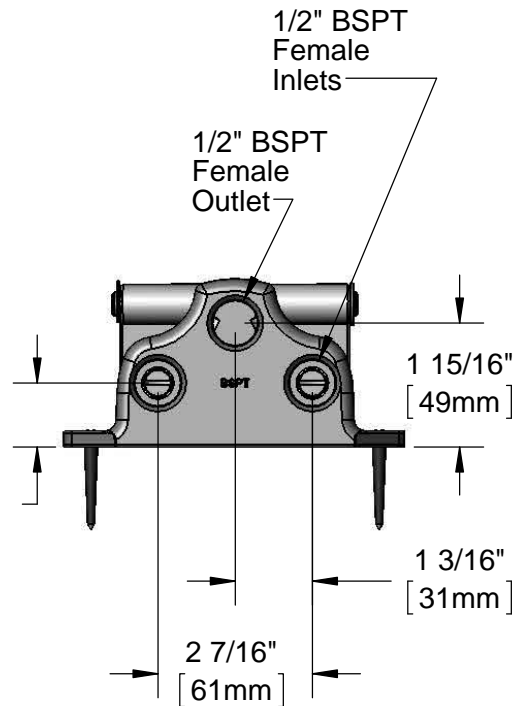
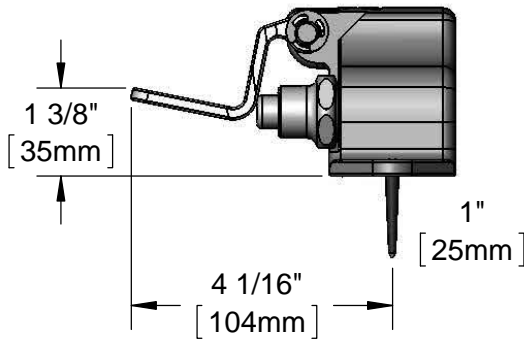
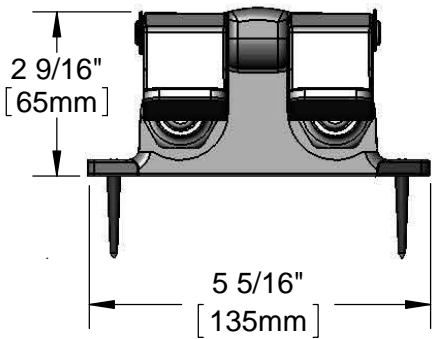
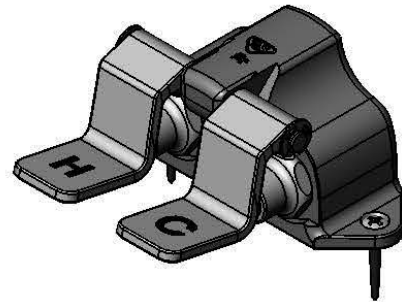

Product Specifications:  
 Double Pedal Valve with 1/2" BSPT Female Inlets & Outlet

Product Compliance:  
 ASME A112.18.1 / CSA B125.1  
 NSF 61 - Section 9  
 NSF 372 (Low Lead Content)

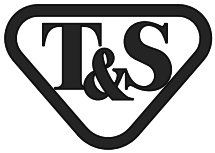

**T&S BRASS AND BRONZE WORKS, INC.**  
2 Saddleback Cove / P.O. Box 1088  
Travelers Rest, SC 29690

Model No.  
**B-0502-BT**

Item No.

Travelers Rest, SC: 800-476-4103 • Simi Valley, CA: 800-423-0150 • Fax: 864-834-3518 • www.tsbrass.com

ITEM NO.	SALES NO.	DESCRIPTION
1	012512-45	E-clip Retaining Ring
2	000092-25	Hot Pedal
3	000915-45	Mounting Screw
4	000091-25	Cold Pedal
5	005312-40	Pedal Valve Bonnet

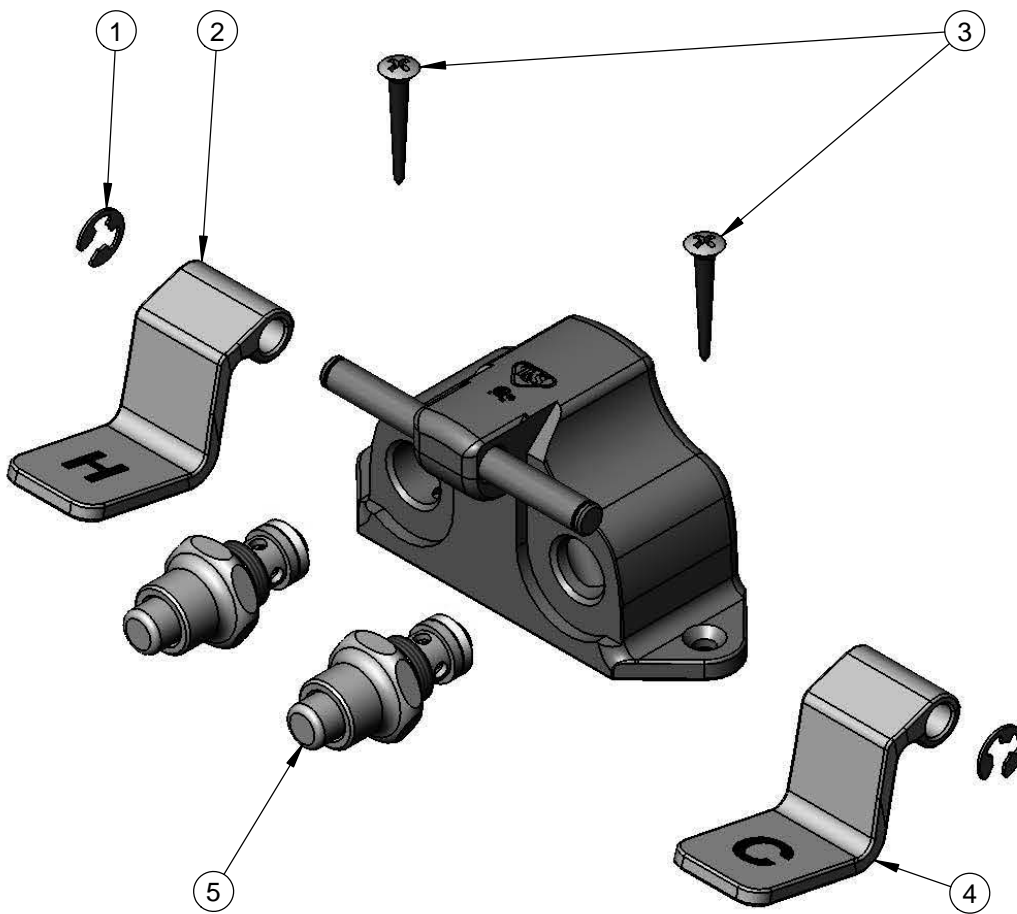

Product Specifications:  
Double Pedal Valve with 1/2" BSPT Female Inlets & Outlet

Product Compliance:  
ASME A112.18.1 / CSA B125.1  
NSF 61 - Section 9  
NSF 372 (Low Lead Content)